

# Upper/Lower Windshield/Rear Glass Tick Noise

**Service Category** Vehicle Exterior

**Section** Window/Glass

**Market** USA

Toyota Supports  
 ASE Certification 

## Applicability

YEAR(S)	MODEL(S)	ADDITIONAL INFORMATION
2003 – 2013	4Runner, Avalon, Avalon HV, Camry, Camry HV, Celica, Corolla, Echo, FJ Cruiser, Highlander, Highlander HV, Land Cruiser, MR2 Spyder, Matrix, Prius, Prius C, Prius PHV, Prius V, RAV4, RAV4 EV, Sequoia, Sienna, Solara, Tacoma, Tundra, Venza, Yaris	

### REVISION NOTICE

April 4, 2013 Rev1:

- Applicability has been updated to include 2012 – 2013 model year Toyota vehicles.
- Introduction, Stopper/Retainer Locations, and Repair Procedure sections have been updated.

Any previous printed versions of this bulletin should be discarded.

### SUPERSESION NOTICE

The information contained in this bulletin supersedes T-SB-0142-08.

- Applicability has been updated to include 2010 – 2011 model year applicable vehicles.

T-SB-0142-08 is Obsolete and any printed versions should be discarded. Be sure to review the entire content of this bulletin before proceeding.

## Upper/Lower Windshield/Rear Glass Tick Noise

### Introduction

If a creak, tick, or rattle noise is heard at the top or bottom of the windshield, or at the top of the rear glass, the source of the noise may be the two stoppers bonded to the top of the windshield/rear glass, or the windshield retainers bonded to the lower edge of the windshield. This bulletin provides the recommended repair procedure to eliminate these types of noises from the windshield/rear glass area.

#### NOTE

- Some vehicles have both stoppers and retainers while others may only have stoppers at the top of the windshield/rear glass. Use the chart in this bulletin to determine the location of the windshield/rear glass locating pins.
- If replacing the windshield glass, please do NOT perform this bulletin until the new glass has been installed.

### Warranty Information

OP CODE	DESCRIPTION	TIME	OFF	T1	T2
NV5019	Remove Top Windshield Locating Stoppers (2)	0.4	5611#-#####	91	41
Combo A	Remove Top Rear Glass Locating Stoppers (2) (only for 09 Corolla if noise from both windshield and rear glass)	0.4			
Combo B	Remove Bottom Windshield Locating Retainers (2) (only as needed for Avalon, Camry, and Solara)	0.3			
NV5020	Remove Bottom Windshield Locating Retainers (2)	0.3	56114-#####		
NV8050	Remove Top Rear Glass Locating Stoppers (2) (only for 09 Corolla if noise from rear glass)	0.4	56116-#####		

#### APPLICABLE WARRANTY

- This repair is covered under the Toyota Comprehensive Warranty. This warranty is in effect for 36 months or 36,000 miles, whichever occurs first, from the vehicle's in-service date.
- Warranty application is limited to occurrence of the specified condition described in this bulletin.

## Upper/Lower Windshield/Rear Glass Tick Noise

---

### Required Tools & Equipment

SPECIAL SERVICE TOOLS (SST)	PART NUMBER	QTY
Plastic Pry Tool Set*	<a href="#">00002-06000-01</a>	1

\* Essential SST.

#### NOTE

Additional SSTs may be ordered by calling 1-800-933-8335.

REQUIRED EQUIPMENT	PART NUMBER	QTY
"Mini" Hacksaw for 10-inch blades (or equivalent)	Snap-On H55A	1

### Stopper/Retainer Locations

MODEL	STOPPERS AT THE TOP OF THE WINDSHIELD	QTY	RETAINERS AT THE BOTTOM OF THE WINDSHIELD	QTY
4Runner	Yes	2	N/A	N/A
Avalon	Yes	2	Yes	2
Avalon HV	Yes	2	Yes	2
Camry	Yes	2	Yes	2
Camry HV	Yes	2	Yes	2
Celica	Yes	2	N/A	N/A
Corolla	Yes	2	N/A	N/A
ECHO	Yes	2	N/A	N/A
FJ Cruiser	Yes	2	N/A	N/A
Highlander	Yes	2	N/A	N/A
Highlander HV	Yes	2	N/A	N/A
Land Cruiser	Yes	2	N/A	N/A
Matrix	Yes	2	N/A	N/A
MR2 Spyder	Yes	2	N/A	N/A
Prius	Yes	2	N/A	N/A
Prius C	Yes	2	N/A	N/A
Prius PHV	Yes	2	N/A	N/A
Prius V	Yes	2	N/A	N/A
RAV4	Yes	2	N/A	N/A
RAV4 EV	Yes	2	N/A	N/A
Sequoia	Yes	2	N/A	N/A

## Upper/Lower Windshield/Rear Glass Tick Noise

### Stopper/Retainer Locations (Continued)

MODEL	STOPPERS AT THE TOP OF THE WINDSHIELD	QTY	RETAINERS AT THE BOTTOM OF THE WINDSHIELD	QTY
Sienna	Yes	2	N/A	N/A
Solara	Yes	2	Yes	2
Tacoma	Yes	2	N/A	N/A
Tundra	Yes	2	N/A	N/A
Venza	Yes	2	Yes	2
Yaris	Yes	2	N/A	N/A

  

MODEL	STOPPERS AT THE TOP OF THE REAR GLASS	QTY	BOTTOM OF REAR GLASS	QTY
2009 Corolla only	Yes	2	N/A	N/A

**Figure 1. Retainer and Stopper Locations**

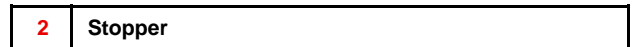
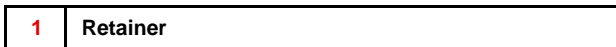
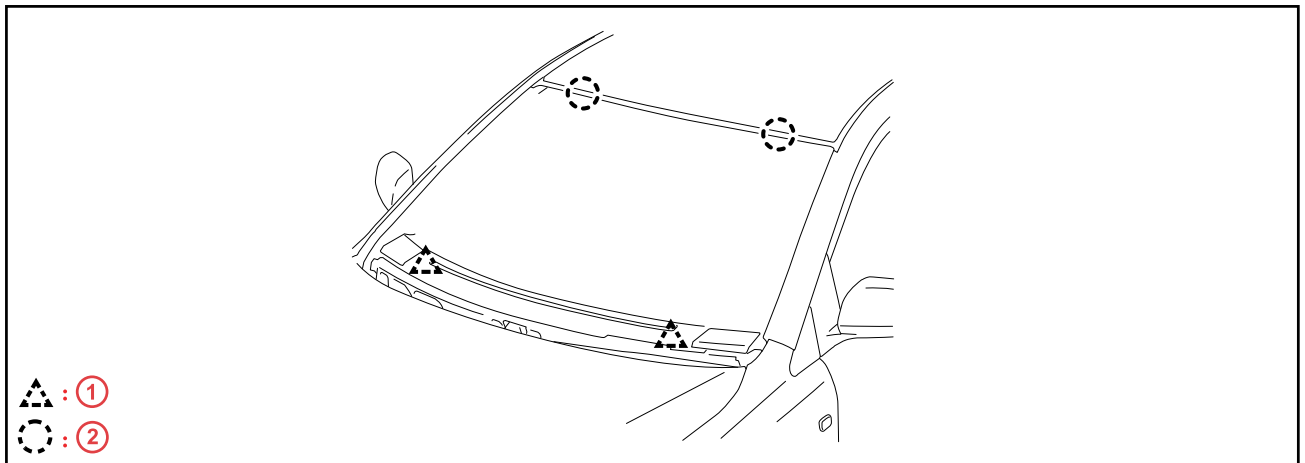

**Figure 2. Retainers**

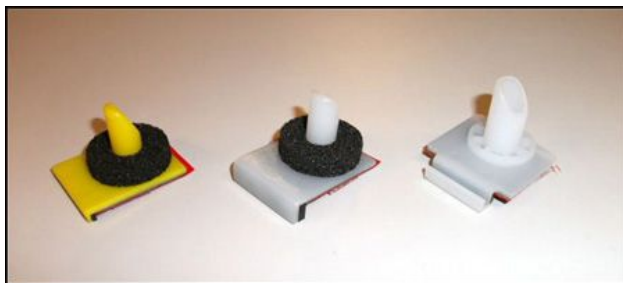

**Figure 3. Stoppers**

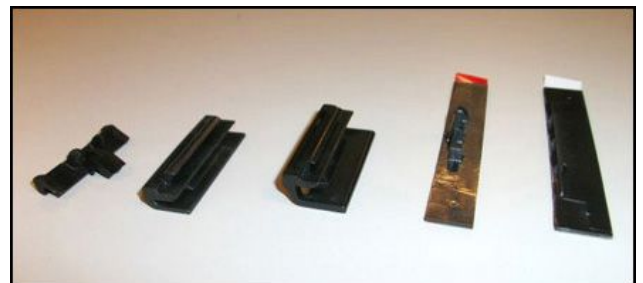

## Upper/Lower Windshield/Rear Glass Tick Noise

### Repair Procedure

#### Windshield Glass Stoppers (at Top of Windshield)

1. Remove both sun visors and both A-pillar garnishes, and then carefully lower the front of the headliner to gain access to the windshield stoppers (refer to the appropriate model year Repair Manual for the proper procedure for removing and reinstalling the sun visors and headliner).

**NOTICE**

It is very important that the front of the headliner be lowered carefully and slowly. Applying too much downward force on the headliner will cause it to develop a permanent crease in the surface material.

The stoppers are located on the inside of the passenger compartment behind the windshield glass blackout section (near the top front edge of the metal roof opening). The stoppers are typically located 200 – 250 mm (7.9 – 9.8 in.) inboard of the top corners of the windshield glass.

Figure 4.

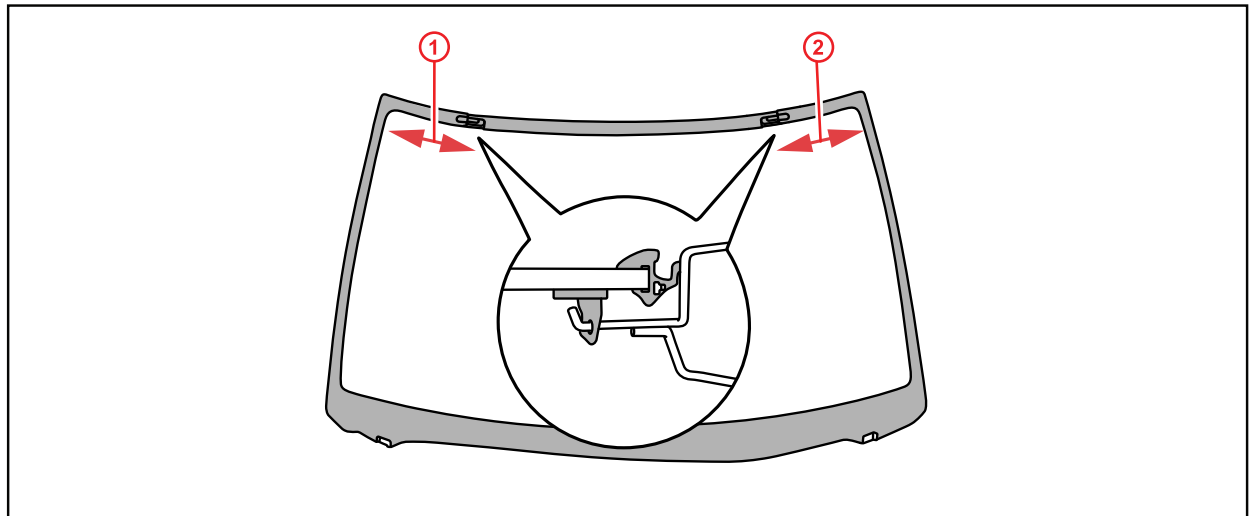

<b>1</b>	200 – 250 mm (7.9 – 9.8 in.)
----------	------------------------------

<b>2</b>	200 – 250 mm (7.9 – 9.8 in.)
----------	------------------------------

## Upper/Lower Windshield/Rear Glass Tick Noise

### Repair Procedure

#### Windshield Glass Stoppers (at Top of Windshield) (Continued)

2. Cut OFF the tip of the plastic stopper as shown in Figure 5.

**NOTE**

Stopper design varies by vehicle model and may not appear exactly as shown below. See Figures 2 and 3 for photos of actual stoppers and retainers.

**HINT**

It is sometimes necessary to bend the metal body tab down to gain access to the shaft of the stopper.

Figure 5.

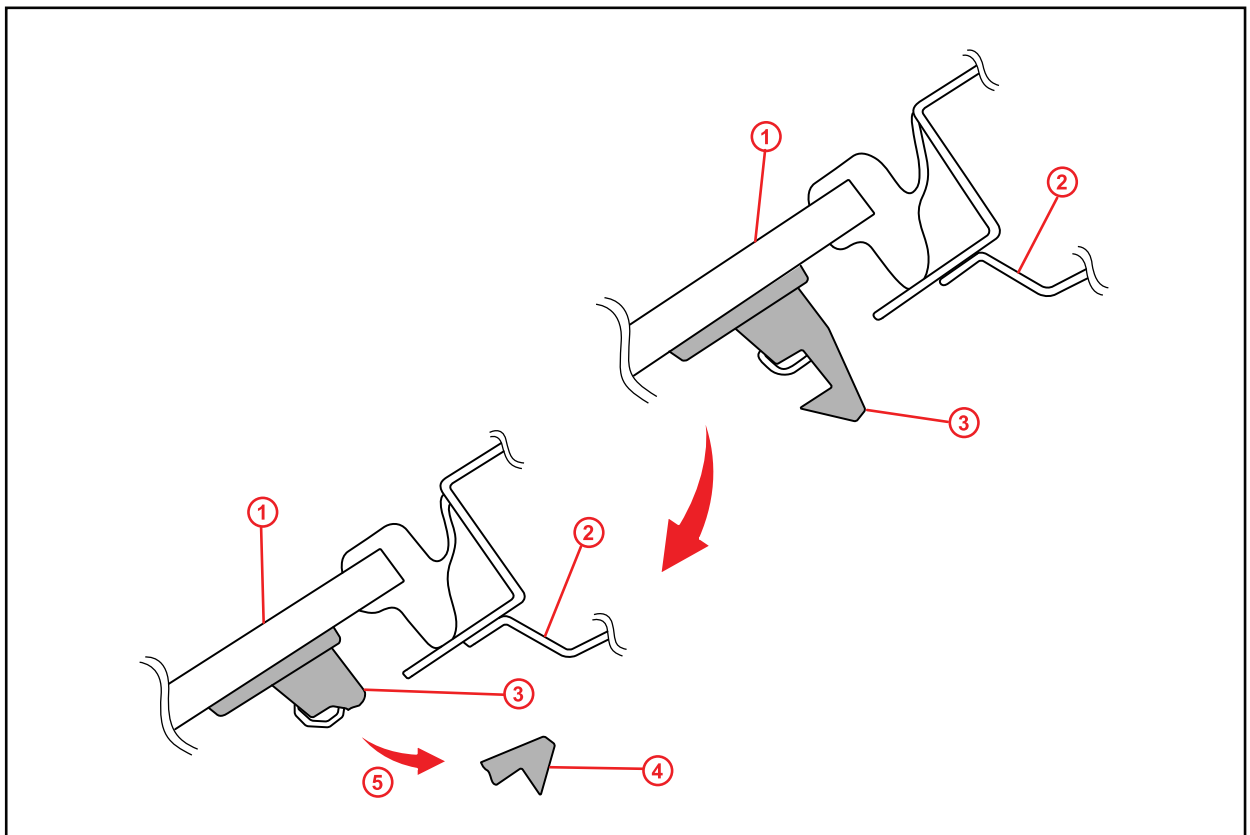

1	Windshield Glass
2	Roof Panel
3	Glass Stopper

4	Fragment of Glass Stopper
5	Cut

## Upper/Lower Windshield/Rear Glass Tick Noise

---

### Repair Procedure

#### Windshield Glass Stoppers (at Top of Windshield) (Continued)

- Once the tip of the stopper has been removed, use a screwdriver to open a gap between the roof panel and the remainder of the plastic windshield stopper.

**NOTICE**

Apply tape to the screwdriver tip before use to prevent scratching.

Figure 6.

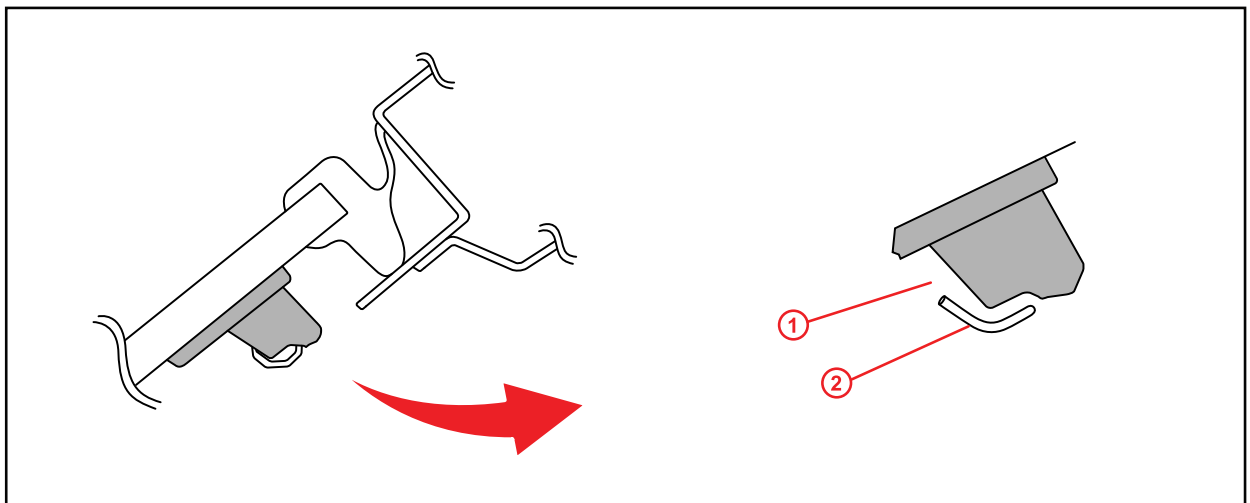

<b>1</b>	<b>Opening Gap</b>
----------	--------------------

<b>2</b>	<b>Roof Panel</b>
----------	-------------------

- Test drive vehicle prior to reassembly to confirm that the noise has been eliminated.
- Reassemble the vehicle.

## Upper/Lower Windshield/Rear Glass Tick Noise

---

### Repair Procedure (Continued)

#### Windshield Retainers (at Lower Edge of Windshield)

1. Carefully remove the plastic cowl top ventilator louver at the base of the windshield and store it in a safe location for reinstallation later (refer to the appropriate model year Repair Manual for the proper procedure).

**Figure 7.**

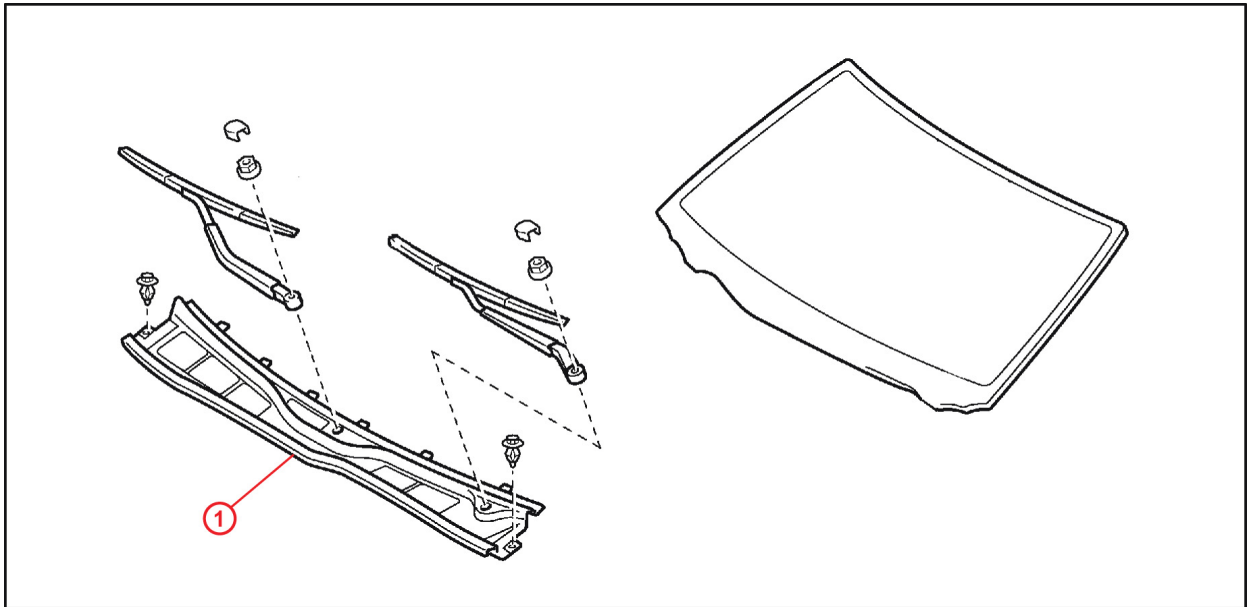

<b>1</b>	<b>Cowl Top Ventilator Louver</b>
----------	-----------------------------------



## Upper/Lower Windshield/Rear Glass Tick Noise

---

### Repair Procedure

#### Windshield Retainers (at Lower Edge of Windshield) (Continued)

2. Locate the lower windshield retainers.

The retainers are typically located 140 – 200 mm (5.5 – 7.9 in.) inboard of the lower corners of the windshield. The flat portion of the retainer is adhered to the backside of the windshield with double-sided, foam-backed tape.

**Figure 8.**

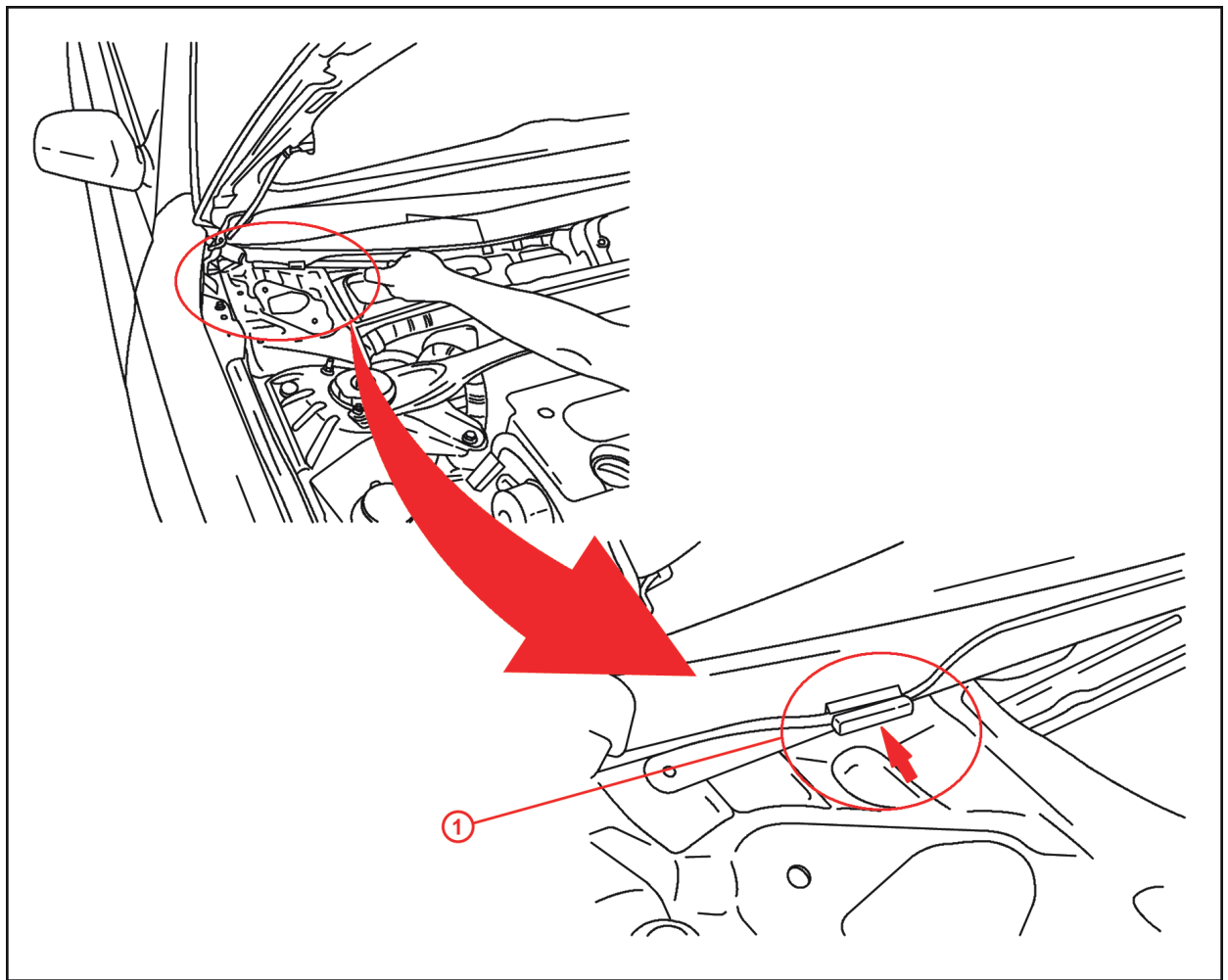

<b>1</b>	<b>Pin Is Attached to Plastic Block Underneath Windshield</b>
----------	---

## Upper/Lower Windshield/Rear Glass Tick Noise

---

### Repair Procedure

#### Windshield Retainers (at Lower Edge of Windshield) (Continued)

3. Use a “mini” hacksaw with a fine tooth 10-inch blade to cut OFF the pin portion of the glass retainer flush with the flat portion of the windshield retainer as shown in Figure 9.

**Figure 9. View from Underneath Windshield**

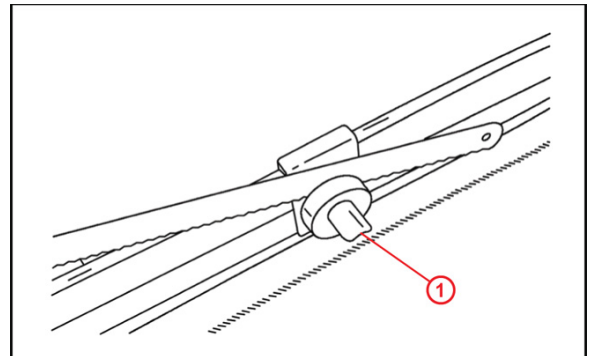

<b>1</b>	<b>Pin</b>
----------	------------

4. Test drive the vehicle to confirm the elimination of the noise.
5. Reinstall the cowl top ventilator louver.

#### Rear Glass Stoppers (at Top of Rear Glass)

For removal of rear glass stoppers, refer to step 1 of the Windshield Glass Stoppers section.