

Short Pin Installation During PDS

Service Category General

Section Pre-Delivery Service

Market USA

Toyota Supports
 ASE Certification 

Applicability

YEAR(S)	MODEL(S)	ADDITIONAL INFORMATION
2011	Prius	

Introduction

To minimize battery discharge during transportation and storage, the Short Pin has been removed at the assembly plant and temporarily stored in the blank space of the Relay Block in the engine compartment. Reinstall the Short Pin into its original location and confirm all related DTCs are cleared during Pre-Delivery Service (PDS).

Required Tools & Equipment

REQUIRED EQUIPMENT	SUPPLIER	PART NUMBER	QTY
TIS Techstream* or Techstream Lite NOTE: Software version 5.10.029 or later is required.	ADE	TSPKG1 or TSLITEDLR01	1

* Essential SST.

NOTE

Additional Techstream units may be ordered by calling Approved Dealer Equipment (ADE) at 1-800-368-6787.

Warranty Information

OP CODE	DESCRIPTION	TIME	OFP	T1	T2
N/A	Not Applicable to Warranty	—	—	—	—

Short Pin Installation During PDS

Installation Procedure

Remove the Short Pin from the blank space of the Relay Block in the engine compartment and install it in its original location during Pre-Delivery Service (PDS).

Figure 1.

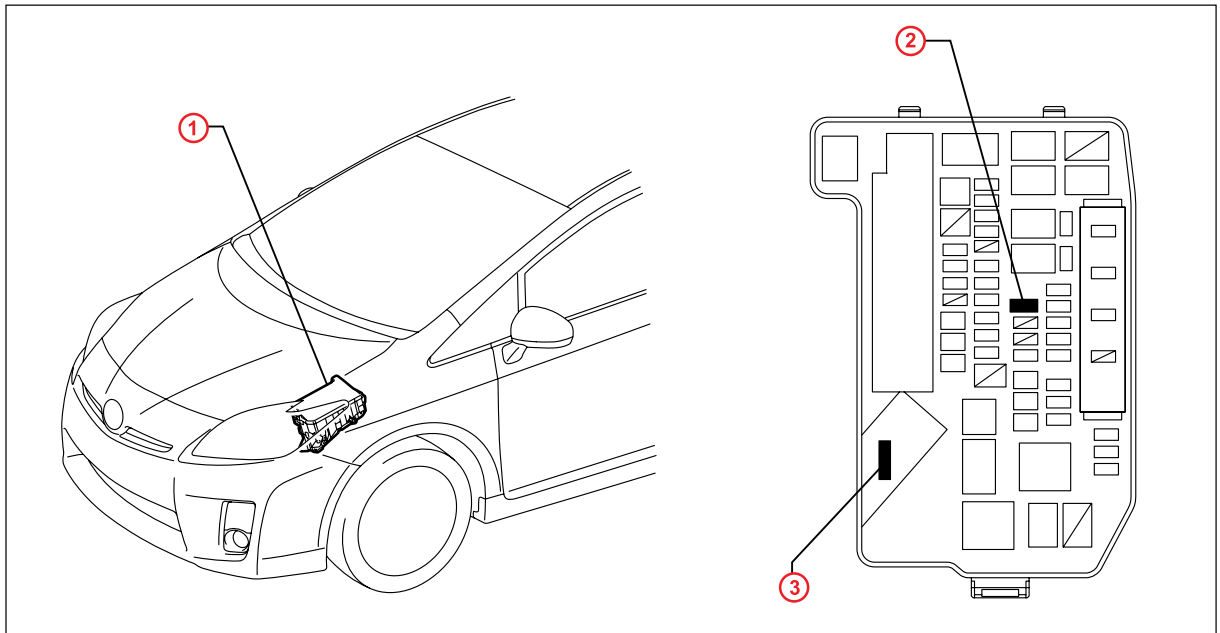

1	Relay Block
2	Install Short Pin Here (Original Location)

3	Short Pin Storage Location
----------	----------------------------

NOTE

If the vehicle is stored for a long period of time after PDS, disconnect the negative (-) battery terminal to prevent battery discharge. Refer to TSB No. [T-SB-0305-10](#), "Maintenance for HV & Auxiliary Batteries," for additional information.

Short Pin Installation During PDS

DTC Clearing Procedure

With the Short Pin removed, the occupant classification ECU and Center Airbag Sensor Assembly (airbag ECU) may detect the interruption in battery voltage (B+) and store a DTC. Clear DTCs B1650 and B1794 after installing the Short Pin.

1. Connect TIS Techstream to the DLC3.
2. Turn the ignition switch to the "IG-ON" position.
3. Using TIS Techstream, check any codes being output.

NOTE

If any DTCs besides DTC B1650 and B1794 remain, repair the applicable system according to the Repair Manual.

4. Erase DTCs (B1650 and B1794) and Freeze Frame Data.