

# SERVICE PLUG GRIP

21041-01

## Removal & Installation and Disassembly & Reassembly

### NOTICE:

- When working on the high voltage systems, always wear insulating gloves.
- After removing the service plug grip, do not operate the power switch as it may damage the hybrid vehicle control ECU.
- Keep the removed service plug in your pocket to prevent other technicians from reconnecting it while you are servicing the vehicle.
- After removing the service plug grip, do not touch the high voltage connectors and terminals for 5 minutes.

### 1. PRECAUTION (See page 21-7)

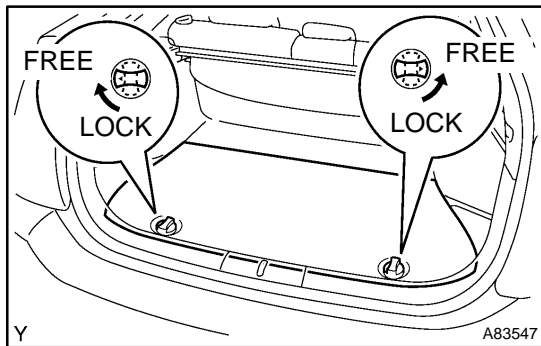

### 2. REMOVE REAR FLOOR BOARD NO.2

- As shown in the illustration, twist the knob and release the lock.
- Remove the rear floor board No. 2.

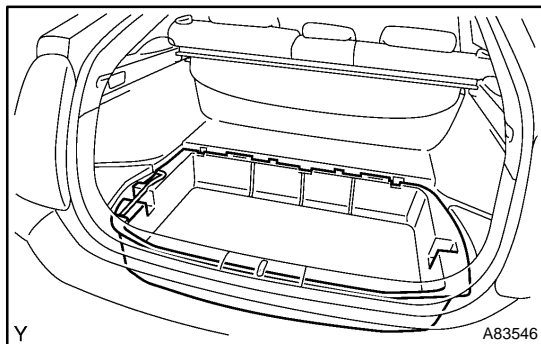

### 3. REMOVE DECK FLOOR BOX REAR

- Remove the deck floor box rear as shown in the illustration.

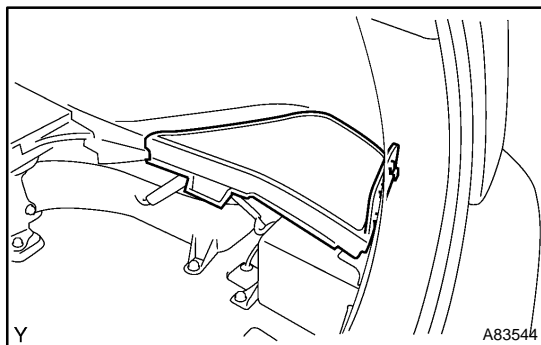

### 4. REMOVE REAR FLOOR BOARD NO.3

- Remove the rear floor board No. 3 as shown in the illustration.

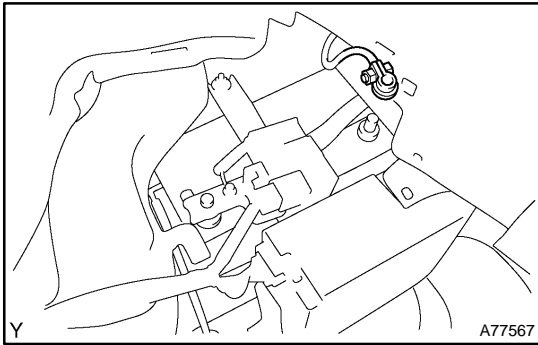

### 5. DISCONNECT BATTERY NEGATIVE TERMINAL

- (a) Disconnect the negative terminal of the 12 V auxiliary battery.

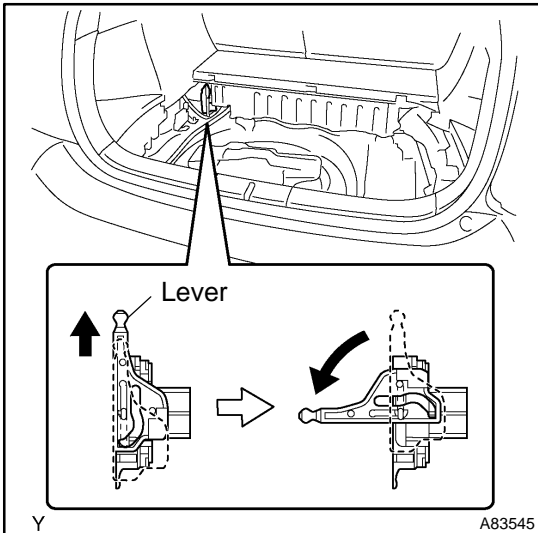

### 6. REMOVE SERVICE PLUG GRIP

#### NOTICE:

**Wear insulating gloves.**

- (a) Slide up the lever of the service plug grip. Remove the service plug grip while turning the lever to the left.  
 (b) Insulate the service plug with insulating tape.

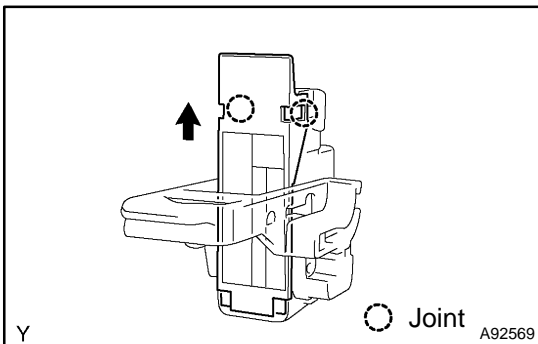

### 7. REMOVE ELECTRIC VEHICLE FUSE

- (a) Remove the 2 joints shown in the illustration, then remove the service plug grip cover.

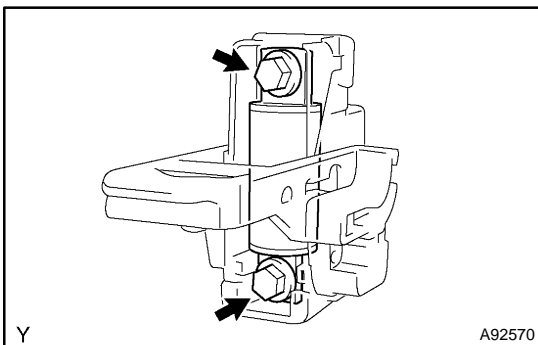

- (b) Remove the 2 bolts and electric vehicle fuse.

### 8. INSTALL ELECTRIC VEHICLE FUSE

- (a) Install the electric vehicle fuse with the 2 bolts.  
**Torque: 5.4 N·m (55 kgf·cm, 48 in·lbf)**  
 (b) Fit the 2 joints, then install the service plug grip cover.

**9. INSTALL SERVICE PLUG GRIP****NOTICE:****Wear insulating gloves.**

- (a) Joint the service plug grip with the HV battery.
- (b) While pushing the service plug grip to the right, rotate the lever to the right.
- (c) Be sure to slide the lever down to lock the service plug grip in place.

**NOTICE:**

- The service plug grip must be locked. If not, it may cause DTCs to output.
- Do not operate the power switch when the service plug grip is not properly locked. It may damage the hybrid vehicle control ECU in rare cases.

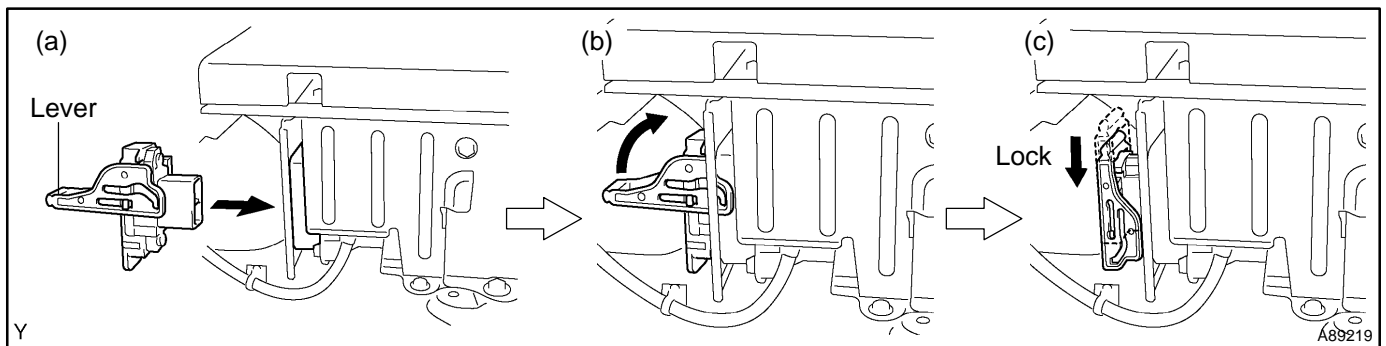
**10. CONNECT BATTERY NEGATIVE TERMINAL**

Torque: 6.0 N·m (61 kgf·cm, 53 in·lbf)

**11. INSTALL REAR FLOOR BOARD NO.3****12. INSTALL DECK FLOOR BOX REAR****13. INSTALL REAR FLOOR BOARD NO.2****14. POWER WINDOW CONTROL SYSTEM INITIALIZE (See page 01-28)**