

COMPONENTS

ILLUSTRATION

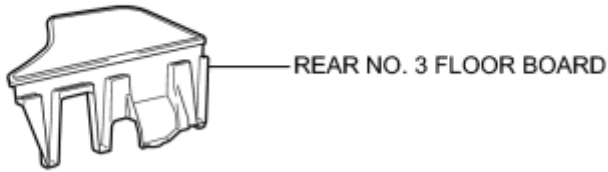

for Integrated Type:

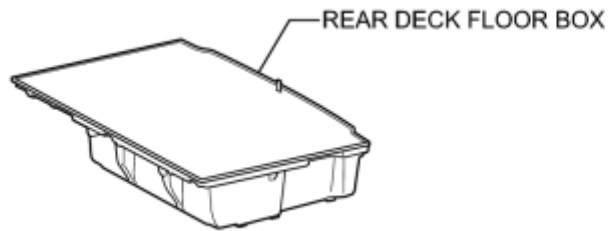

for Separate Type:

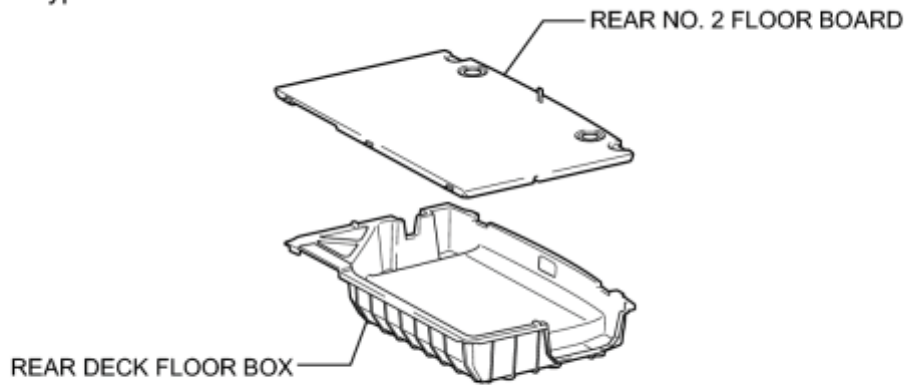

P

ILLUSTRATION

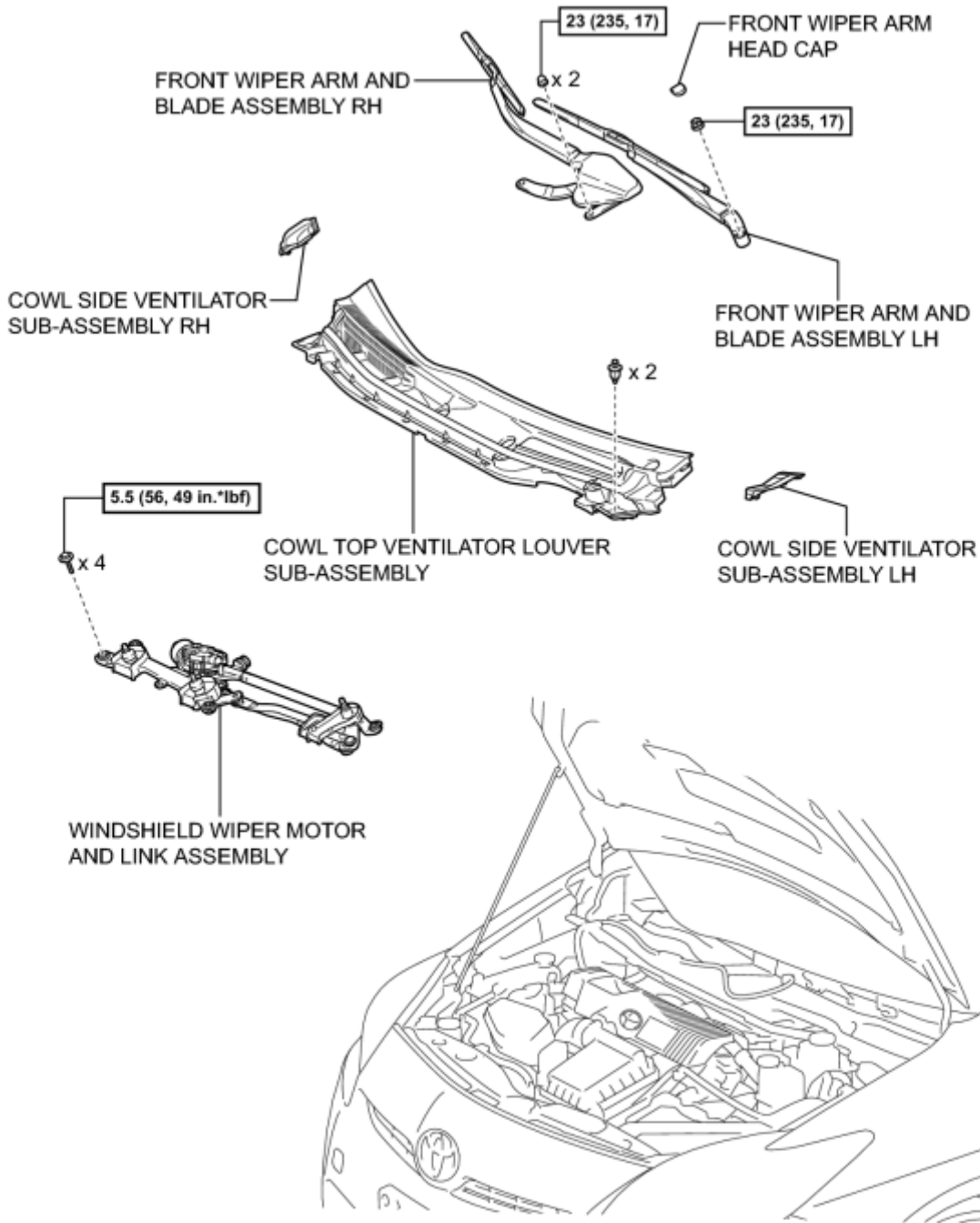

ILLUSTRATION

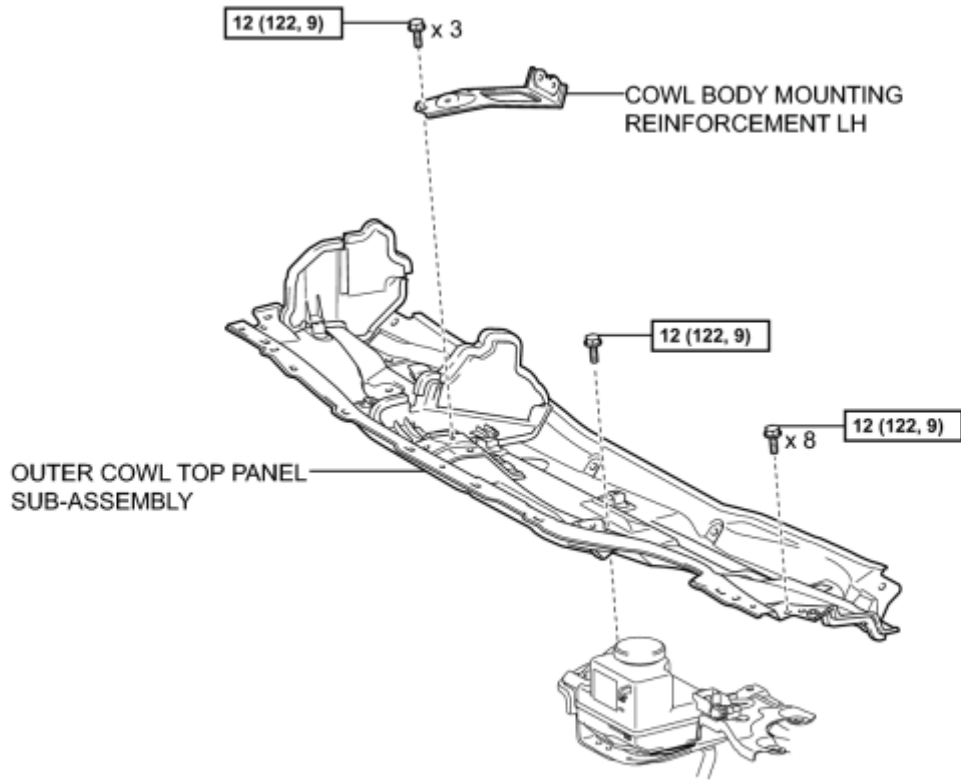

N*m (kgf*cm, ft.*lbf) : Specified torque

P

ILLUSTRATION

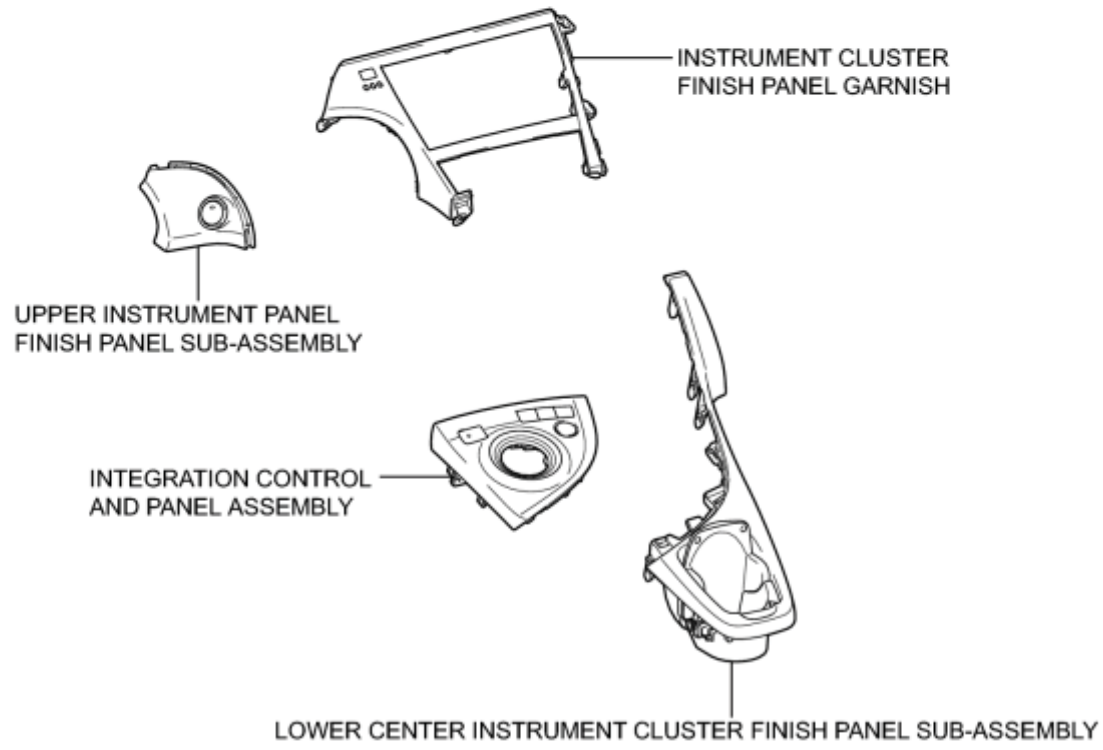
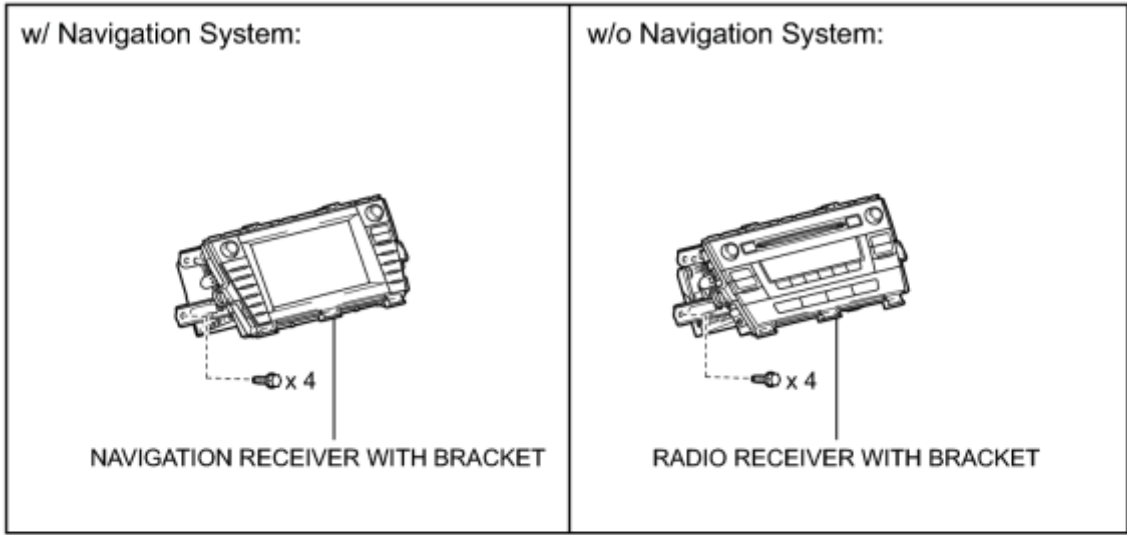

P

ILLUSTRATION

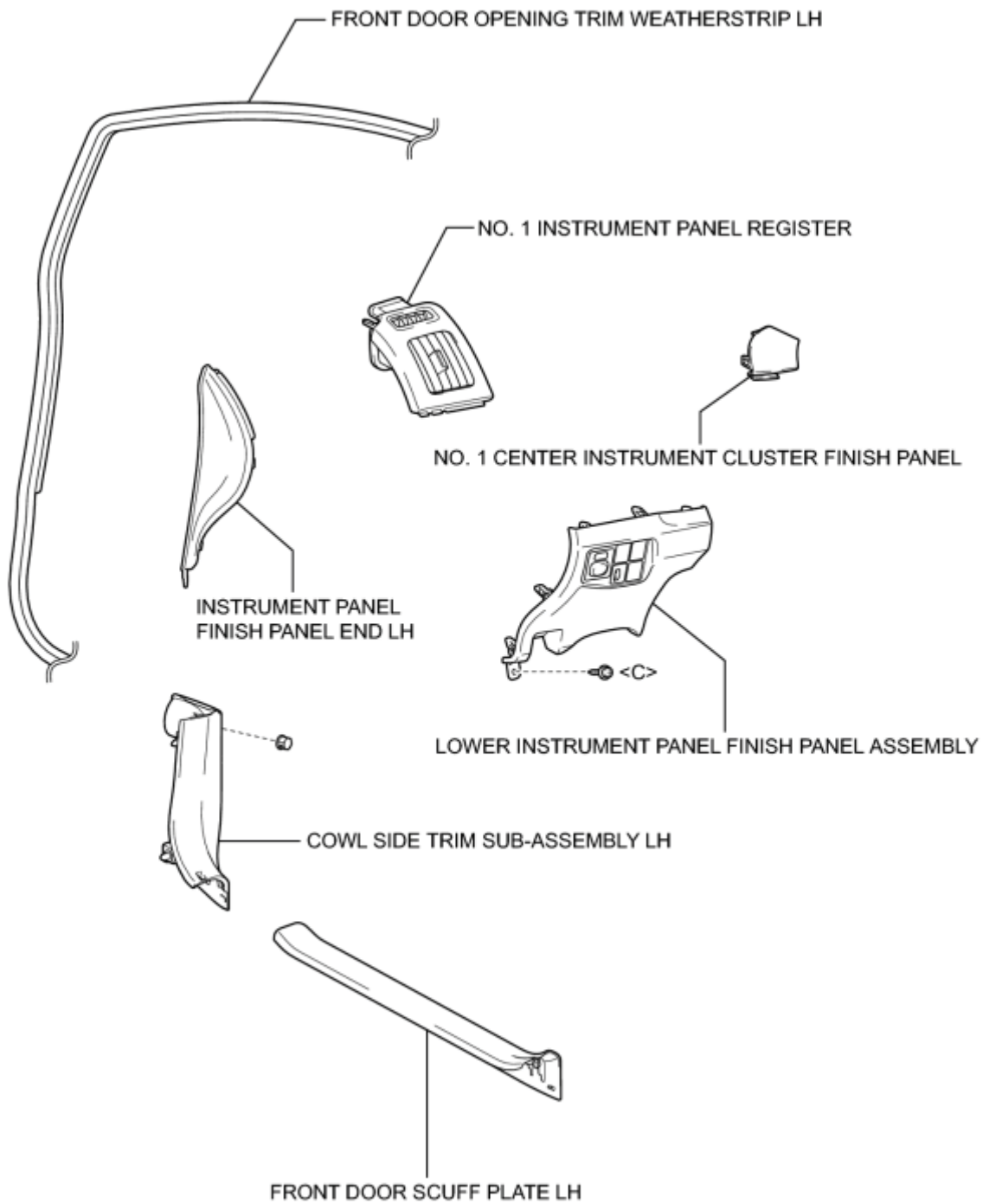

P

ILLUSTRATION

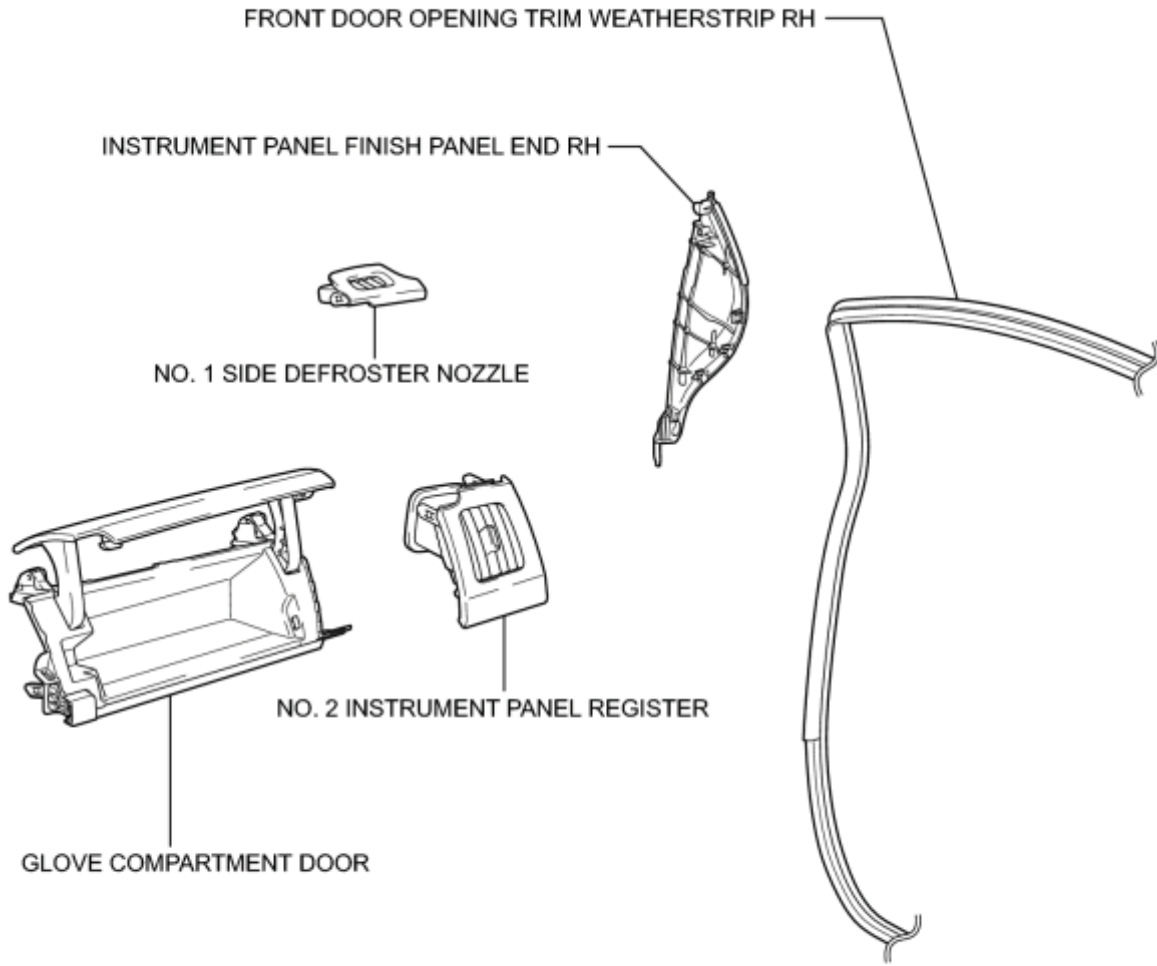

P

ILLUSTRATION

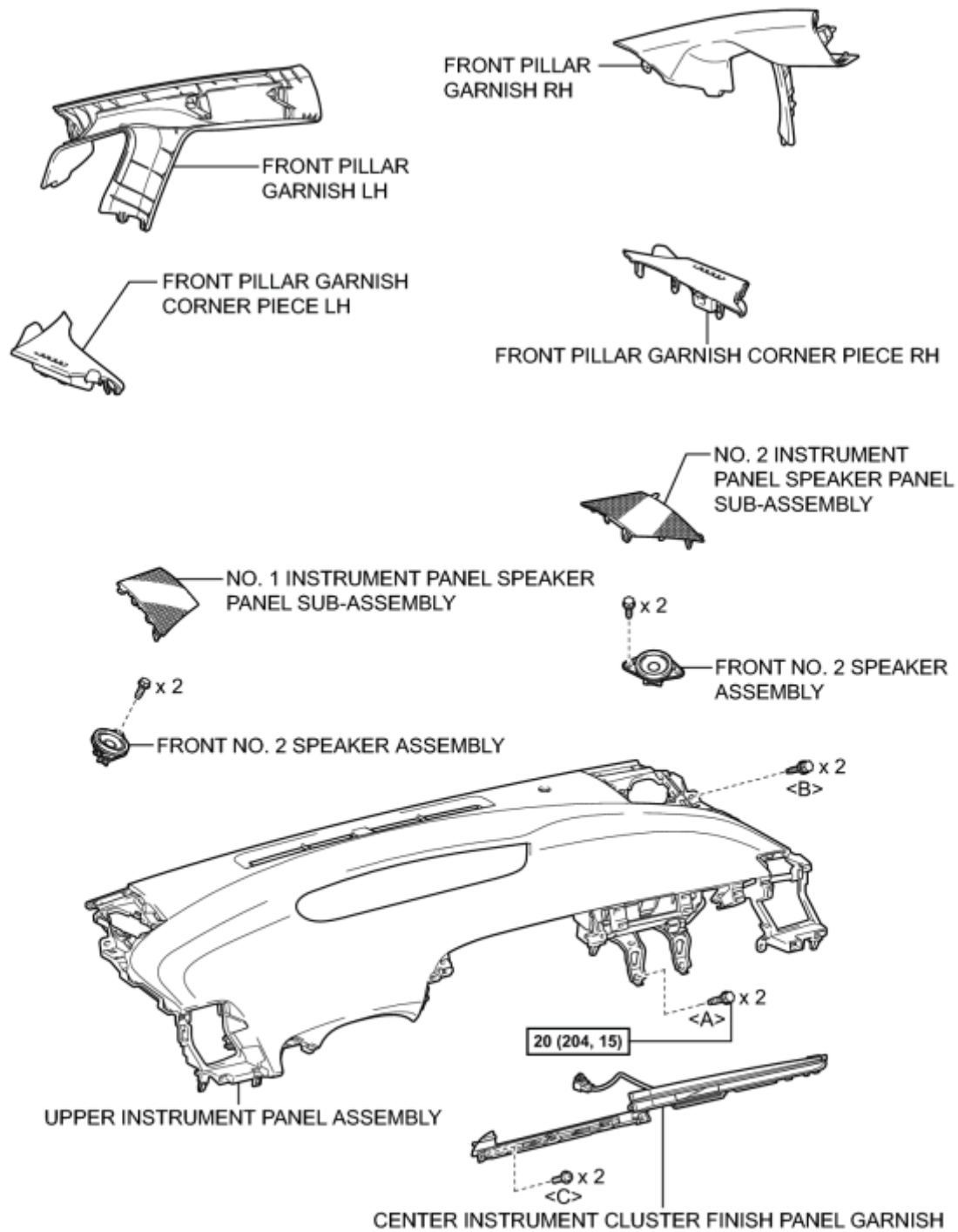

N*m (kgf*cm, ft.*lbf) : Specified torque

P

ILLUSTRATION

w/ Power Outlet Socket:

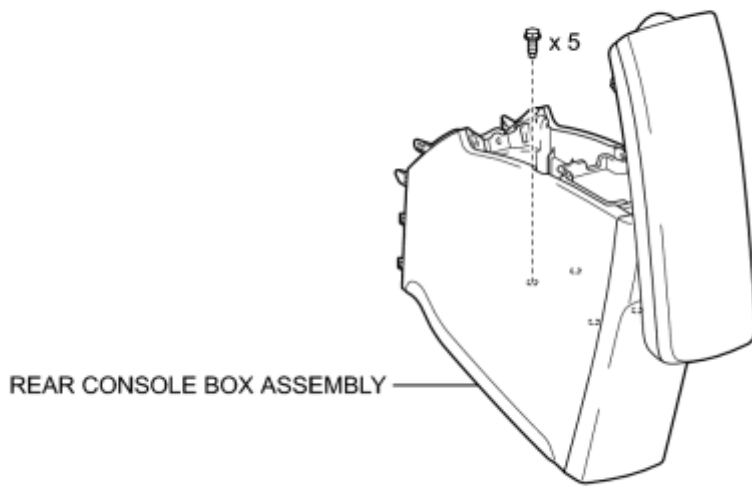
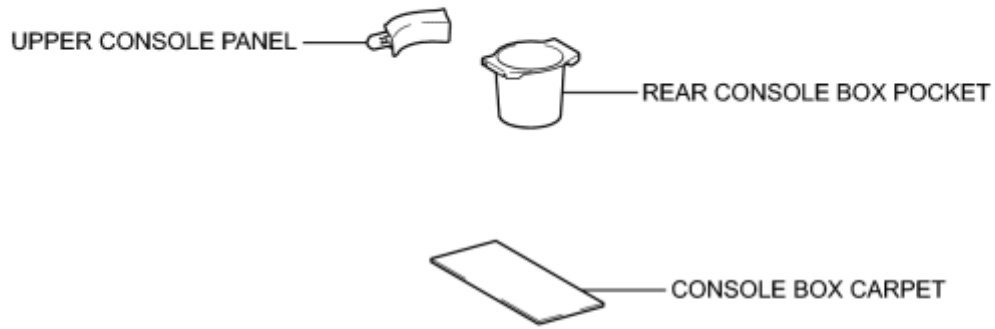

P

ILLUSTRATION

w/o Power Outlet Socket:

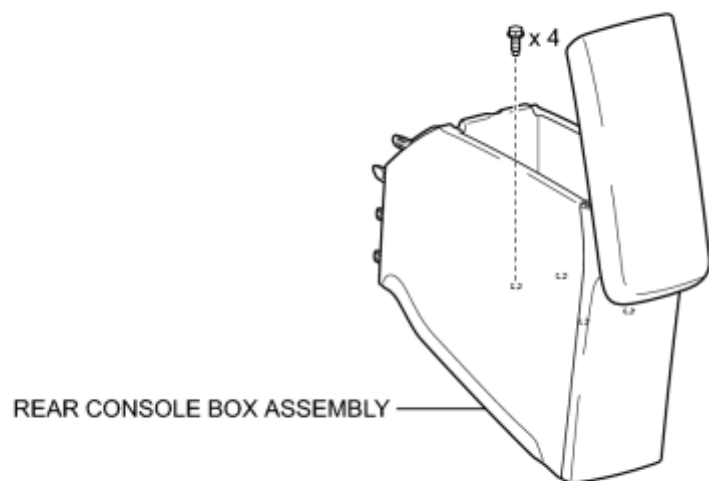

P

ILLUSTRATION

AIR CONDITIONING CONTROL ASSEMBLY



SHIFT LOCK CONTROL UNIT ASSEMBLY

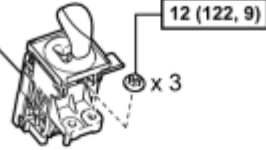

12 (122, 9)

x 3

UPPER INSTRUMENT PANEL FINISH PANEL ASSEMBLY

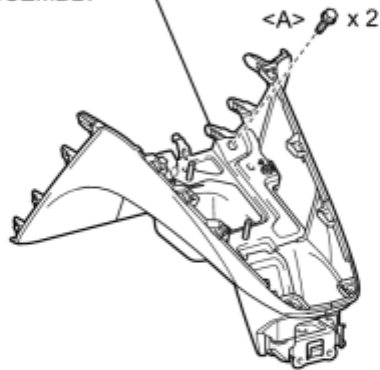

<A> x 2

FRONT NO. 1 CONSOLE BOX INSERT



FRONT NO. 2 CONSOLE BOX INSERT



BOX BOTTOM MAT

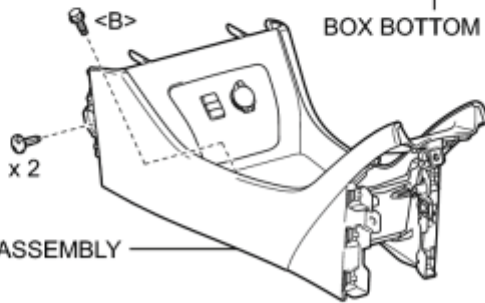

x 2

CONSOLE BOX ASSEMBLY

NO. 2 CONSOLE BOX MOUNTING BRACKET

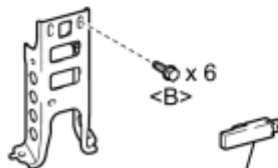

x 6

ELECTRICAL KEY OSCILLATOR



N·m (kgf·cm, ft.*lbf) : Specified torque

P

ILLUSTRATION

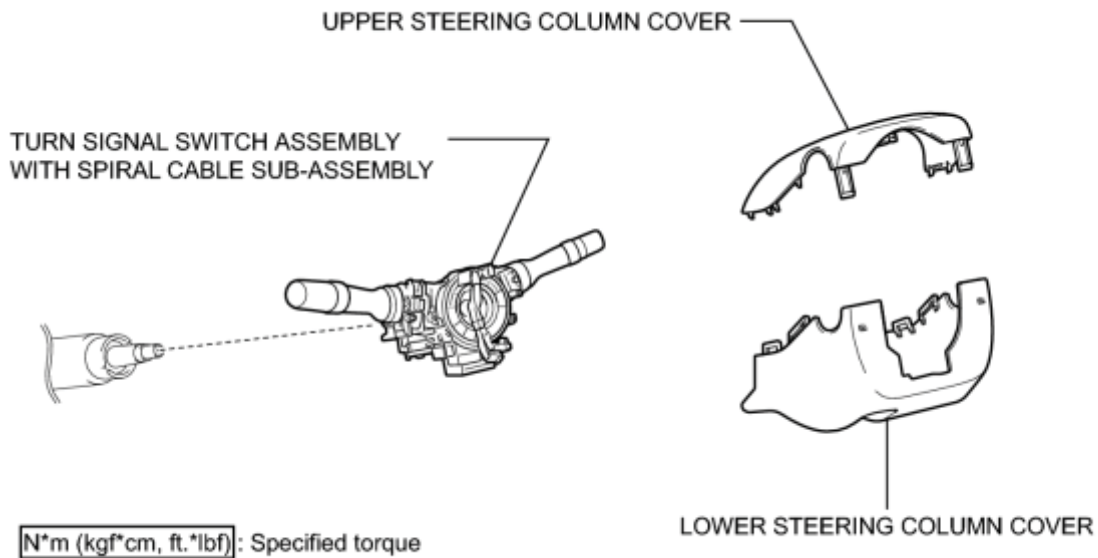
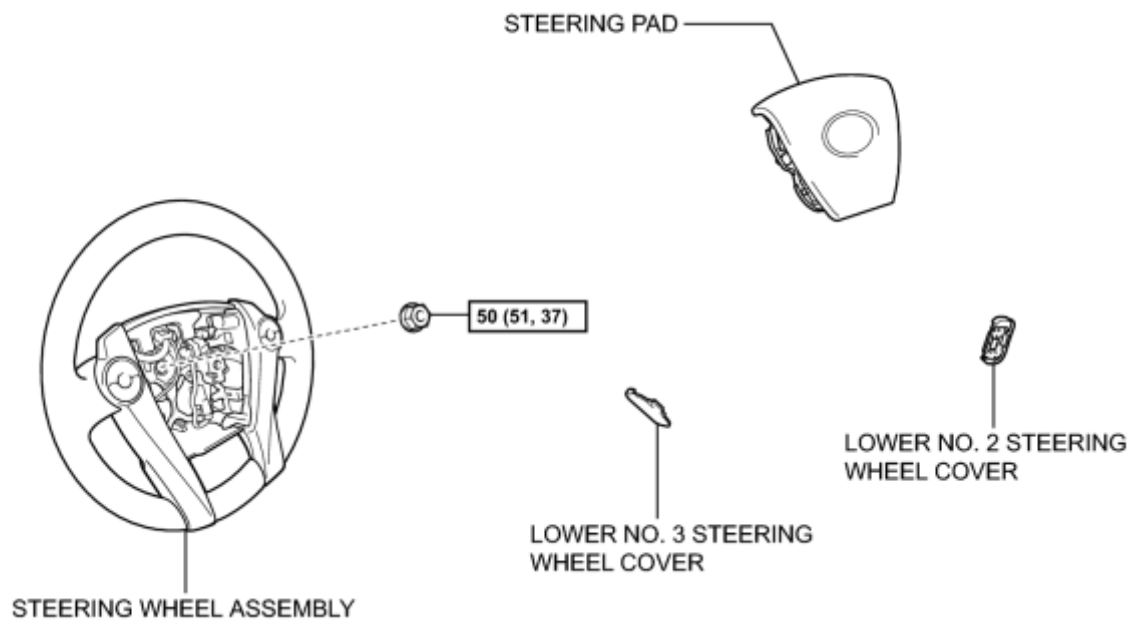

ILLUSTRATION

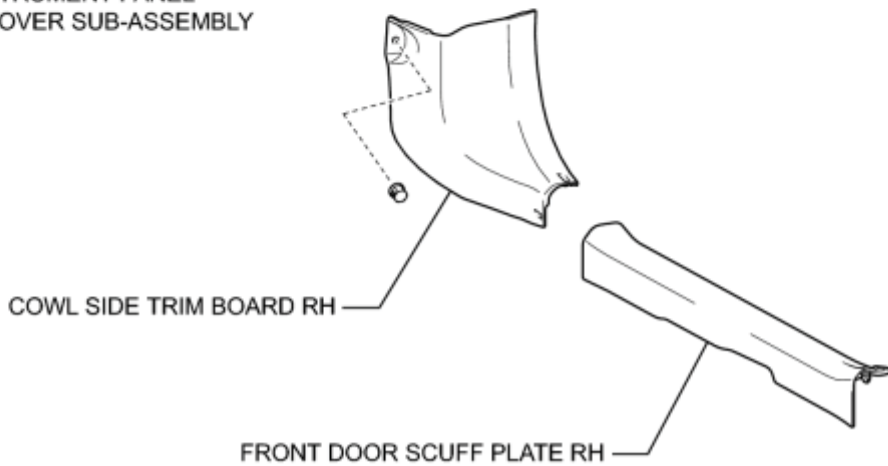
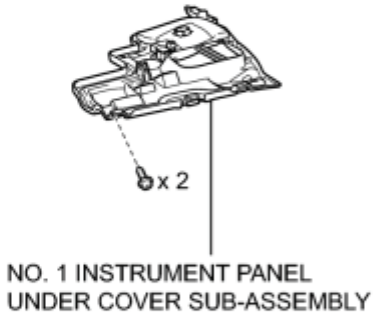
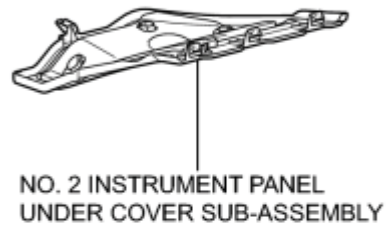
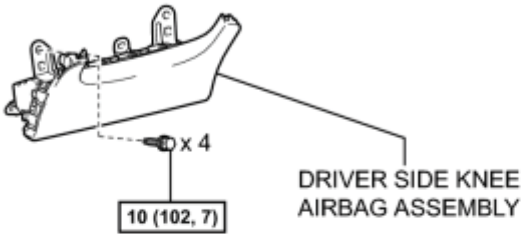
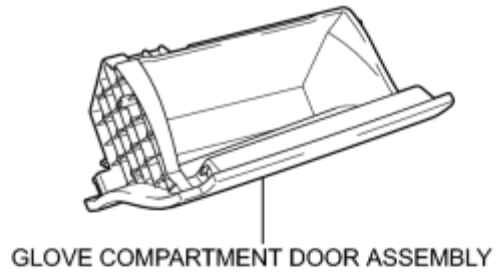
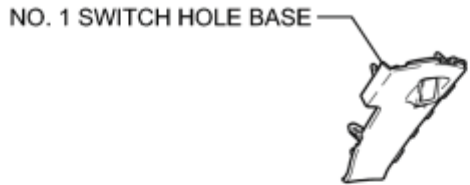

N*m (kgf*cm, ft.*lbf): Specified torque

P

ILLUSTRATION

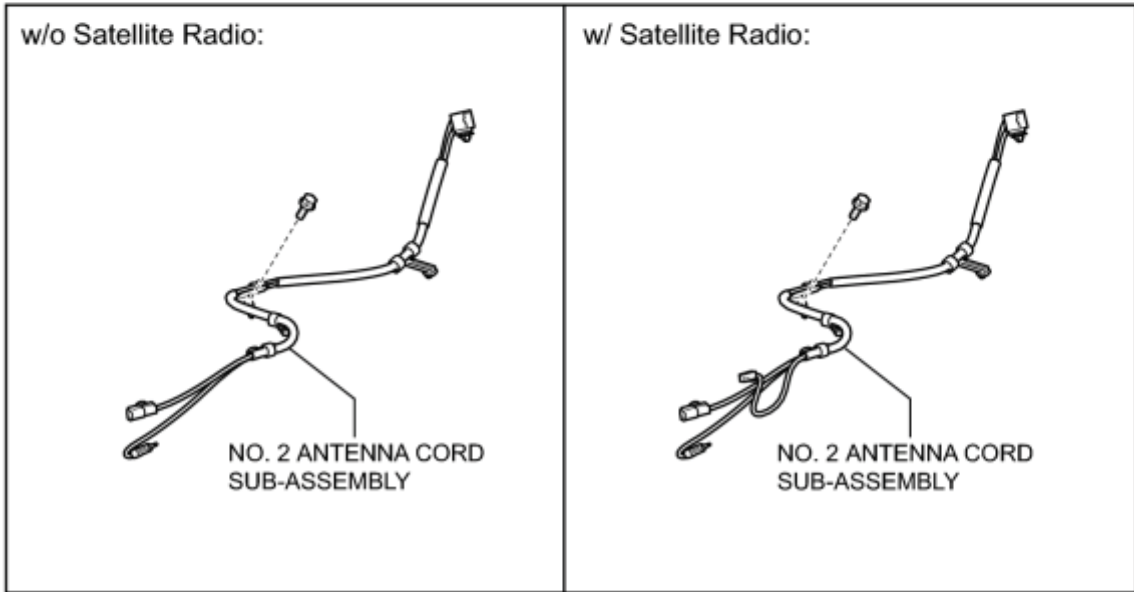
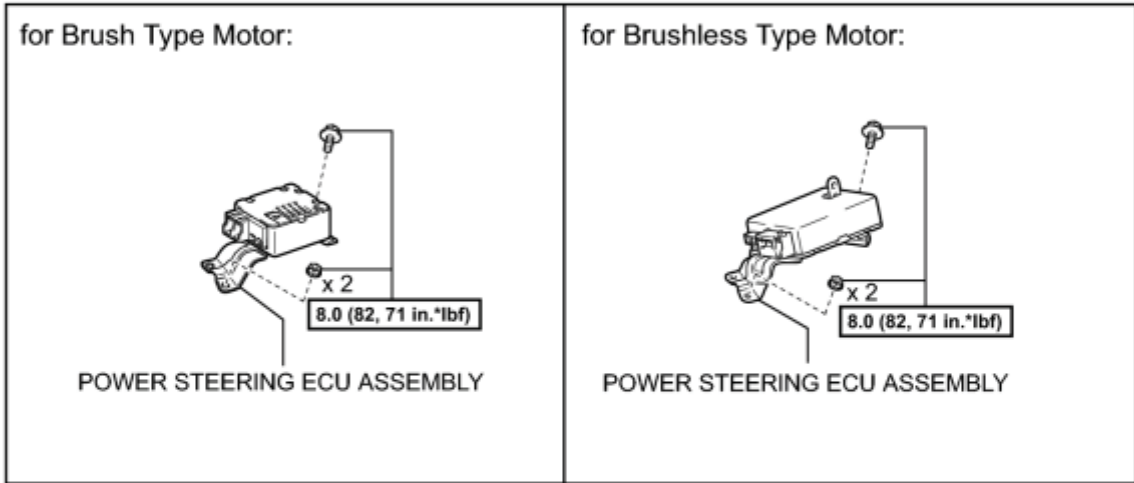
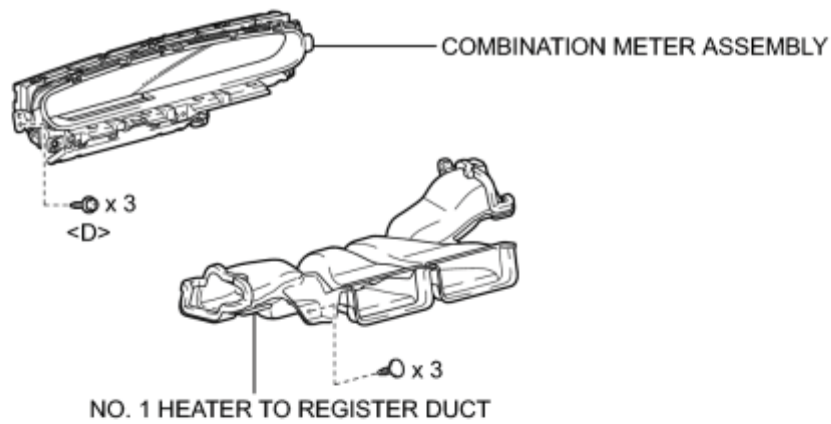

N*m (kgf*cm, ft.*lbf): Specified torque

P

ILLUSTRATION

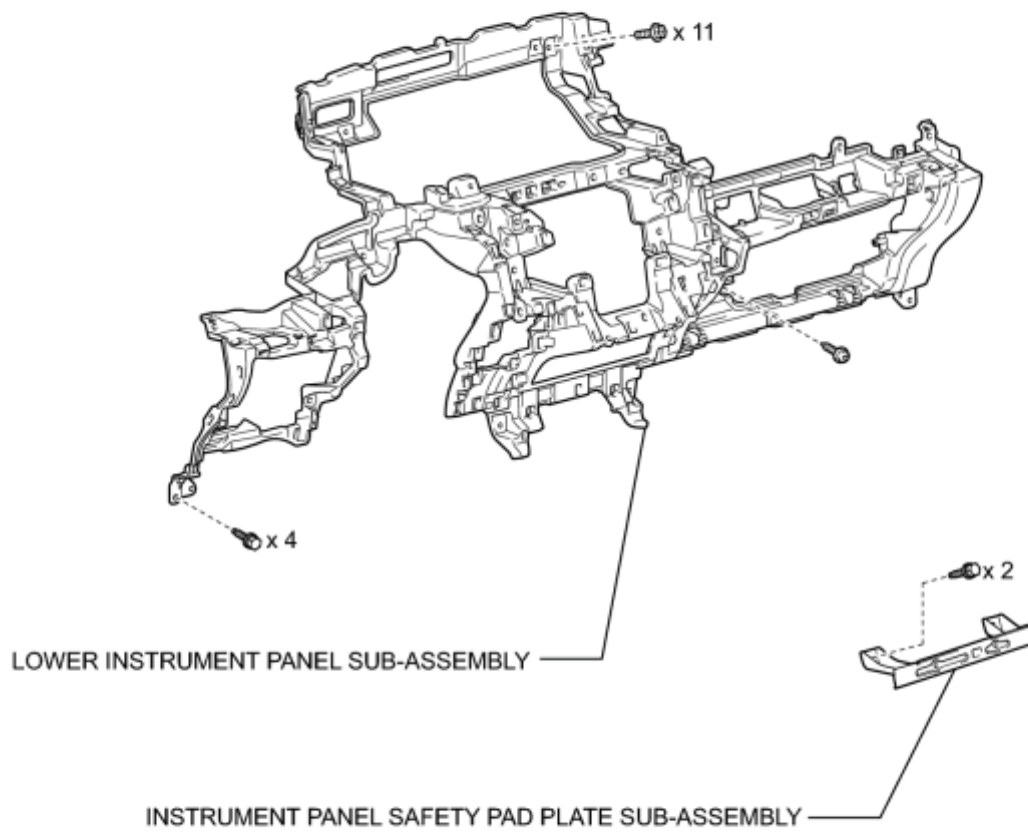

P

ILLUSTRATION

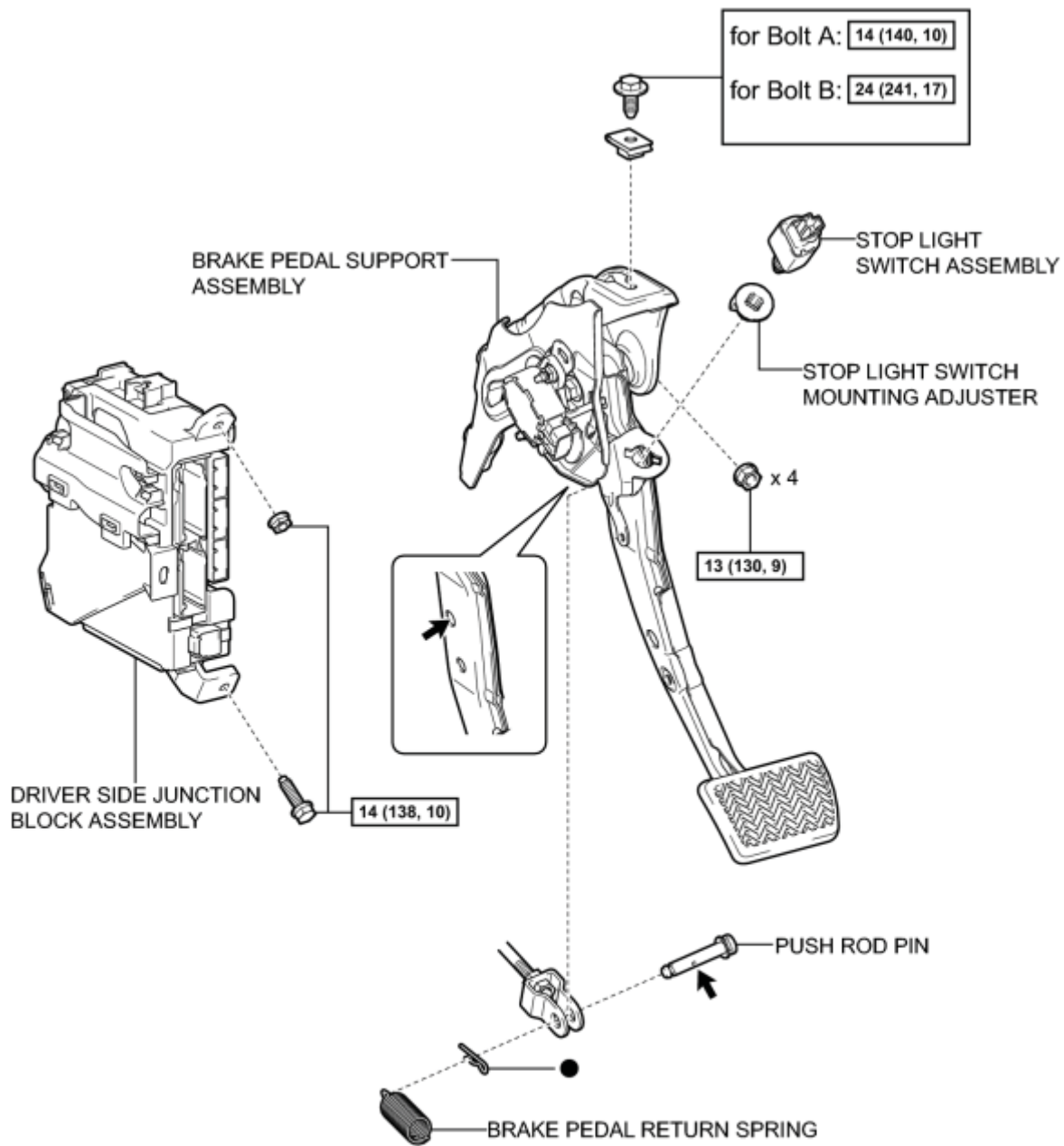

N*m (kgf*cm, ft.*lbf) : Specified torque

● Non-reusable part

← Lithium soap base glycol grease

P

ILLUSTRATION

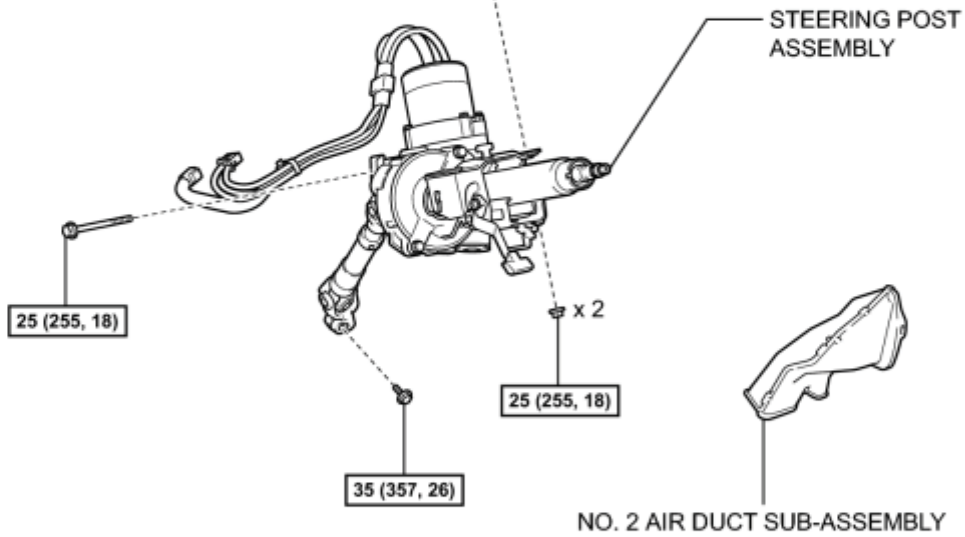
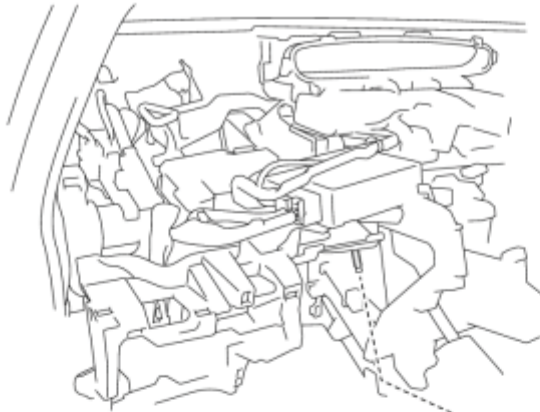

N*m (kgf*cm, ft.*lbf): Specified torque

c

ILLUSTRATION

w/ Rear Air Duct:

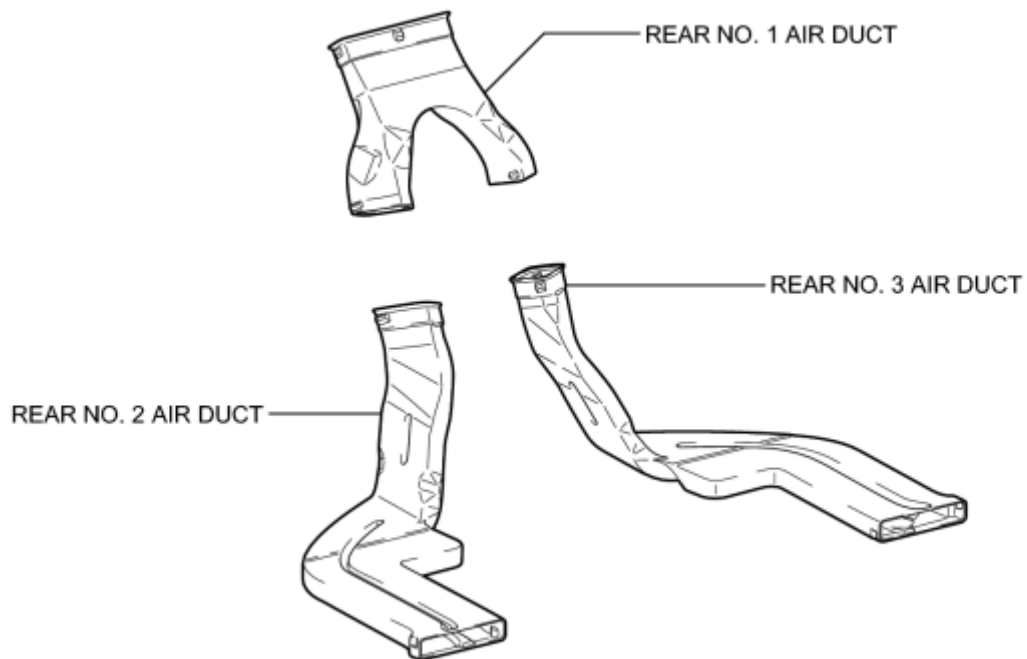

P

ILLUSTRATION

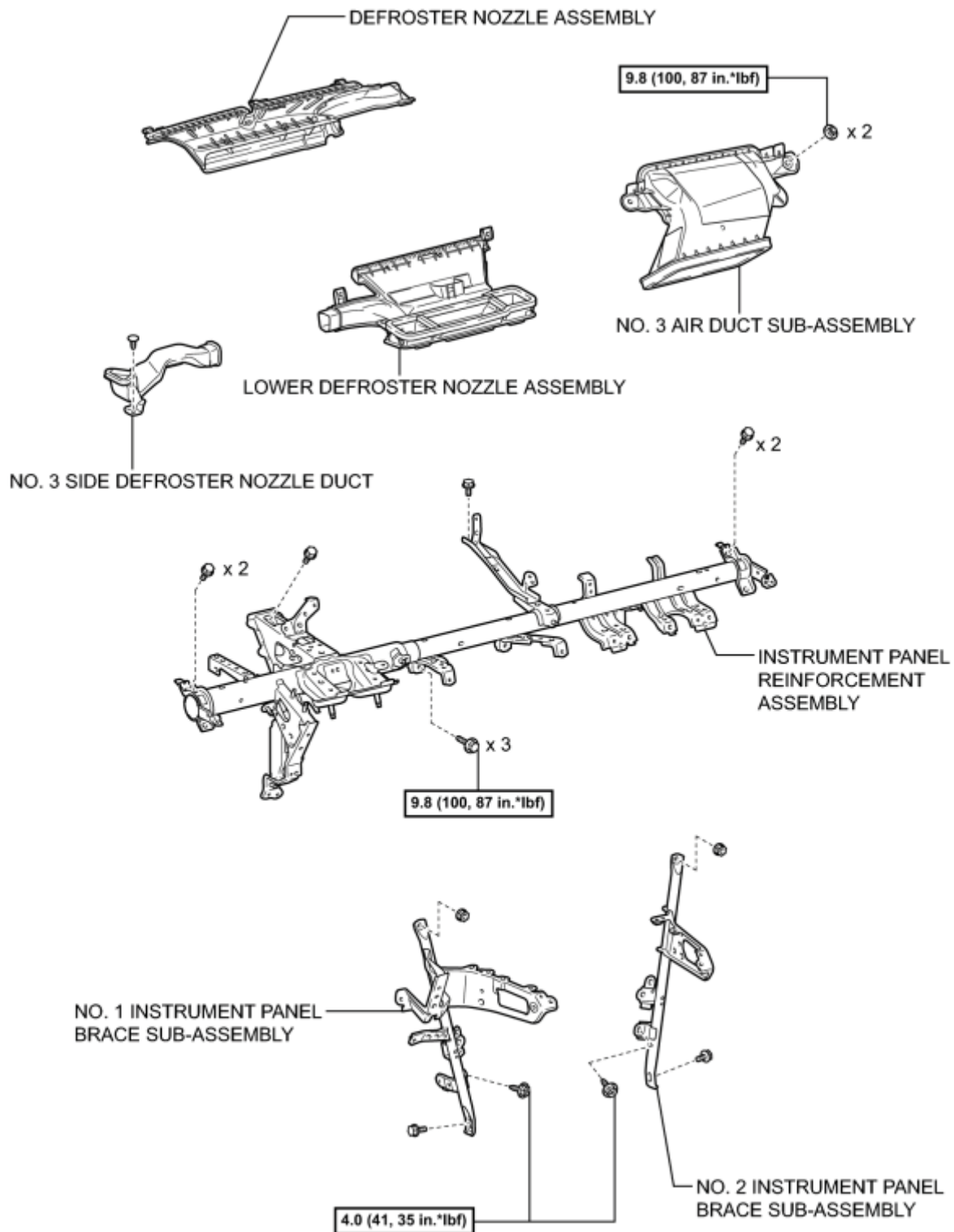

[N*m (kgf*cm, ft.*lbf)]: Specified torque

P

ILLUSTRATION

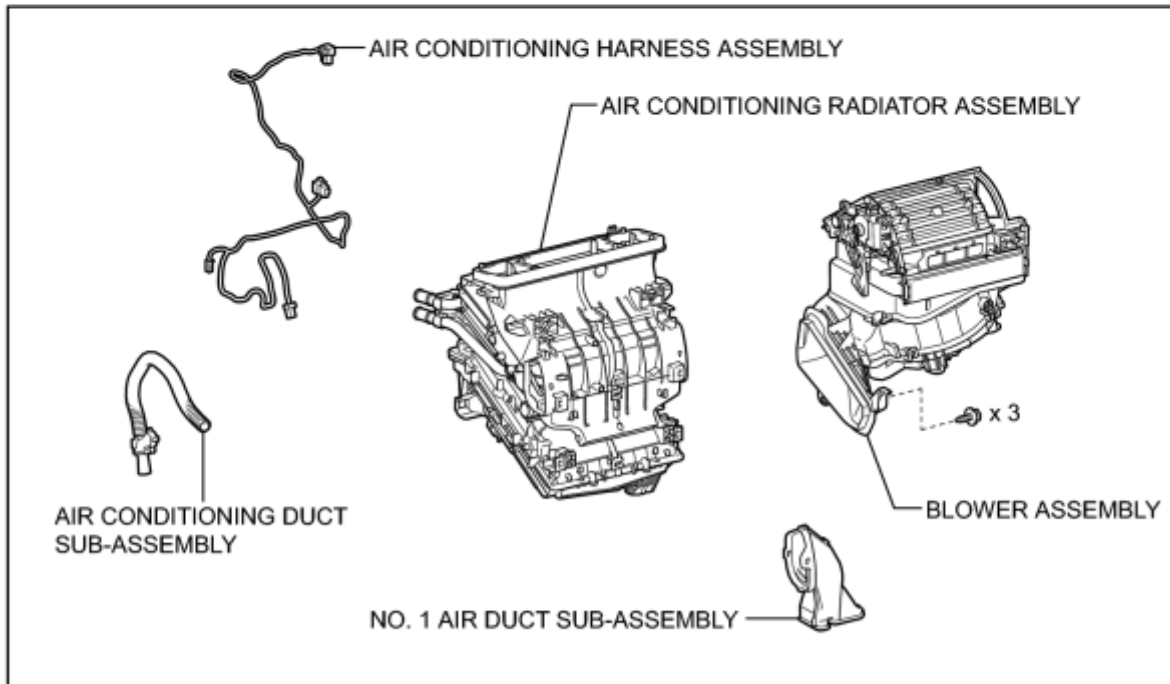
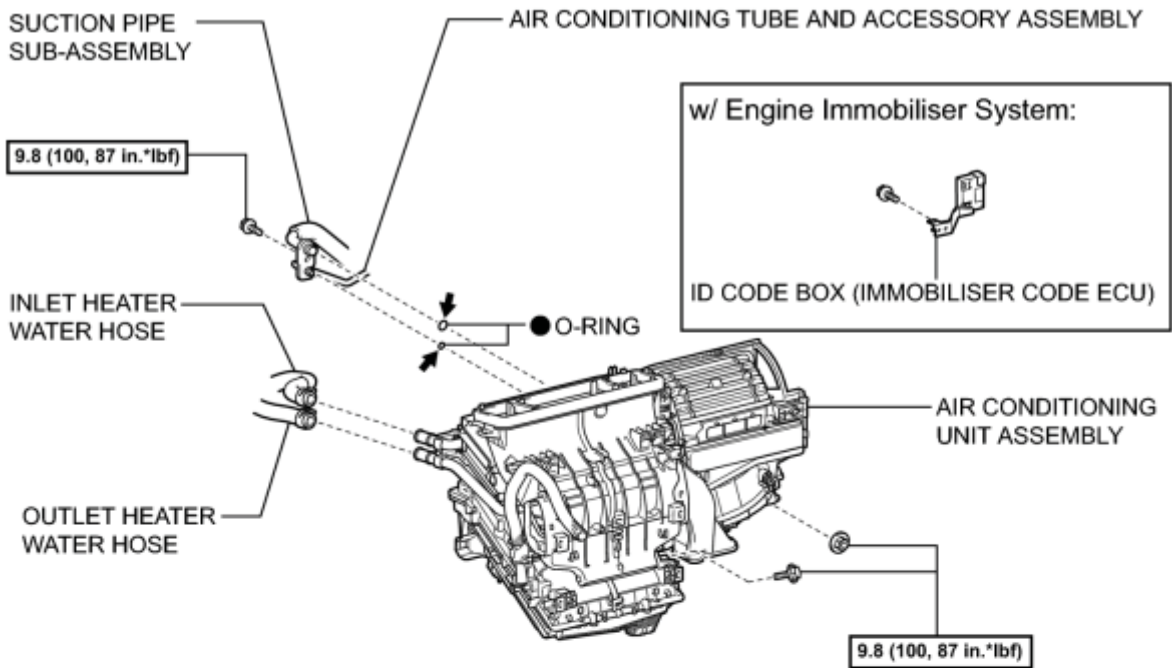

[N*m (kgf*cm, ft.*lbf)]: Specified torque

● Non-reusable part

← Compressor oil ND-OIL 11 or equivalent

P

ILLUSTRATION

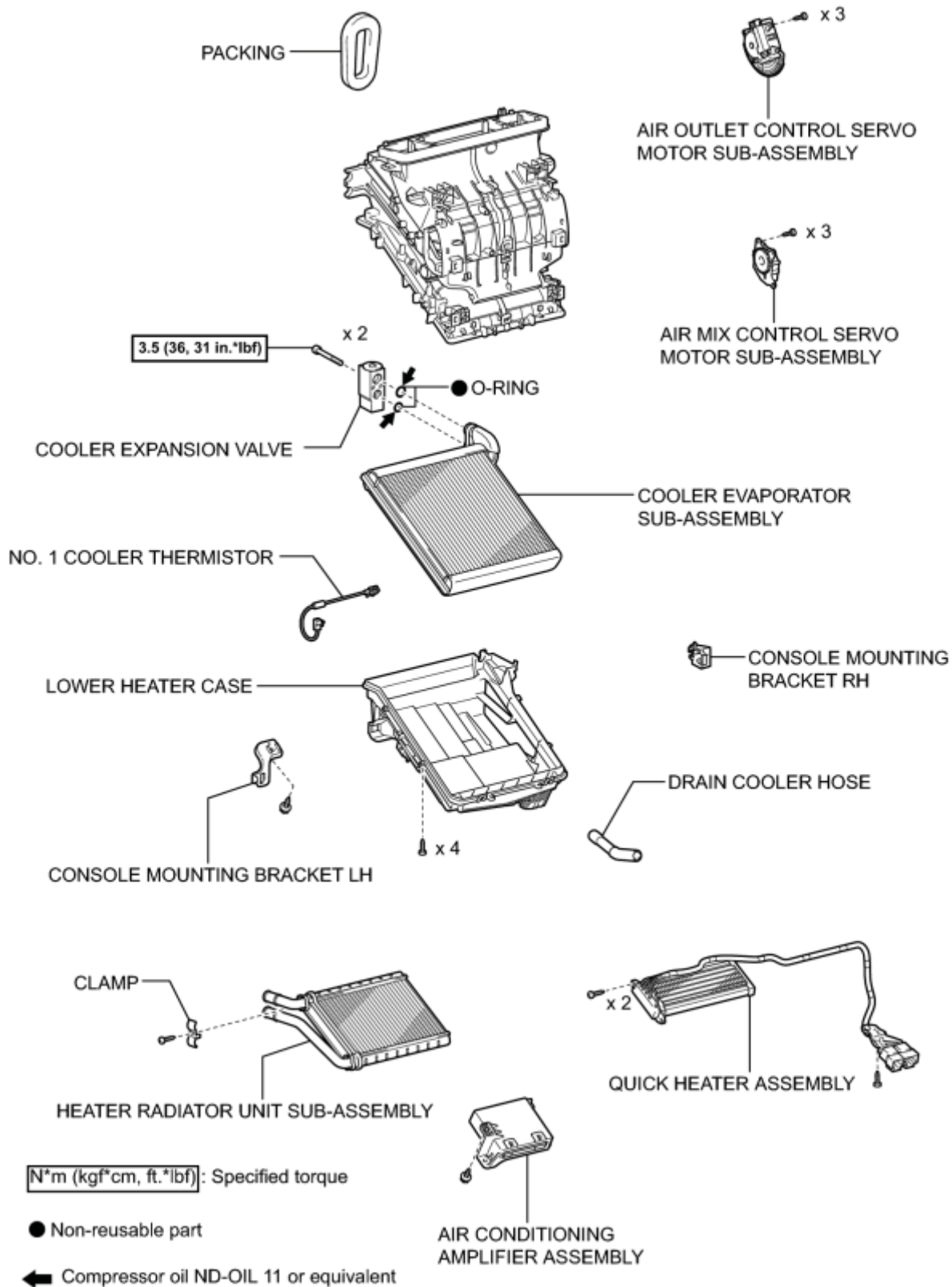

P

REMOVAL

1. PRECAUTION

INFO

HINT:

Before disconnecting the cable, set the air conditioning control switch to DEF-MODE. (for Automatic Air Conditioning System)

2. RECOVER REFRIGERANT FROM REFRIGERATION SYSTEM_

INFO

3. ALIGN FRONT WHEELS STRAIGHT AHEAD

4. REMOVE REAR NO. 2 FLOOR BOARD (for Separate Type)_

INFO

5. REMOVE REAR DECK FLOOR BOX_

INFO

6. REMOVE REAR NO. 3 FLOOR BOARD_

INFO

7. DISCONNECT CABLE FROM NEGATIVE BATTERY TERMINAL

CAUTION:

Wait at least 90 seconds after disconnecting the cable from the negative (-) battery terminal to disable the SRS system.

NOTICE:

When disconnecting the cable, some systems need to be initialized after the cable is reconnected.

INFO

8. REMOVE FRONT WIPER ARM HEAD CAP_

INFO

9. REMOVE FRONT WIPER ARM AND BLADE ASSEMBLY LH_

INFO

10. REMOVE FRONT WIPER ARM AND BLADE ASSEMBLY RH_

INFO

11. REMOVE COWL SIDE VENTILATOR SUB-ASSEMBLY LH_

INFO

12. REMOVE COWL SIDE VENTILATOR SUB-ASSEMBLY RH_

INFO

13. REMOVE COWL TOP VENTILATOR LOUVER SUB-ASSEMBLY_

INFO

14. REMOVE WINDSHIELD WIPER MOTOR AND LINK ASSEMBLY_

INFO

15. REMOVE COWL BODY MOUNTING REINFORCEMENT LH_

INFO

16. REMOVE OUTER COWL TOP PANEL SUB-ASSEMBLY_

INFO

17. DISCONNECT SUCTION PIPE SUB-ASSEMBLY

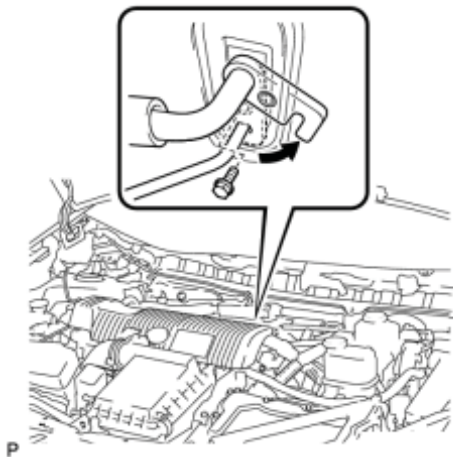

(a) Remove the bolt and slide the hook connector.

(b) Disconnect the suction pipe assembly.

(c) Remove the O-ring from the suction pipe sub-assembly.

NOTICE:

Seal the openings of the disconnected parts using vinyl tape to prevent entry of moisture and foreign matter.

18. DISCONNECT AIR CONDITIONING TUBE AND ACCESSORY ASSEMBLY

(a) Disconnect the air conditioning tube and accessory assembly.

(b) Remove the O-ring from the air conditioning tube and accessory assembly.

NOTICE:

Seal the openings of the disconnected parts using vinyl tape to prevent entry of moisture and foreign matter.

19. DISCONNECT INLET HEATER WATER HOSE

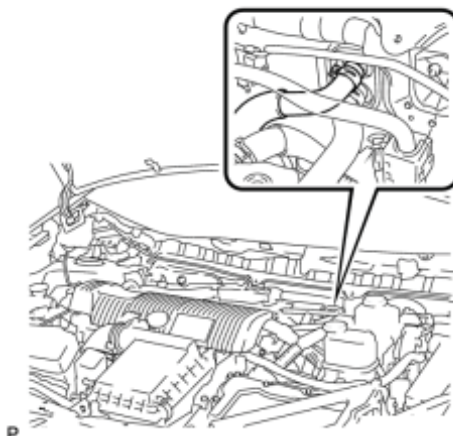

(a) Using pliers, grip the claws of the clip and slide the clip to disconnect the inlet heater water hose.

- Do not apply excessive force to the inlet heater water hose.
- Prepare a drain pan or cloth in case the coolant leaks.

20. DISCONNECT OUTLET HEATER WATER HOSE

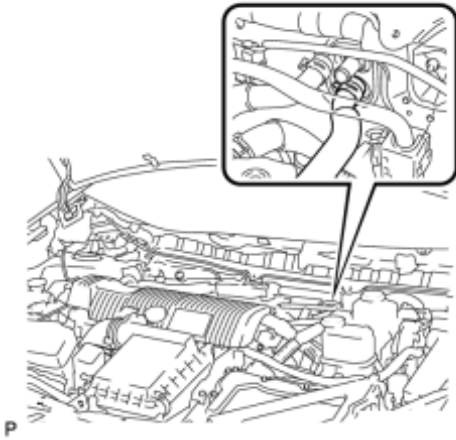

(a) Using pliers, grip the claws of the clip and slide the clip to disconnect the outlet heater water hose.

- Do not apply excessive force to the outlet heater water hose.
- Prepare a drain pan or cloth in case the coolant leaks.

21. REMOVE INTEGRATION CONTROL AND PANEL ASSEMBLY_ [INFO](#)

22. REMOVE LOWER CENTER INSTRUMENT CLUSTER FINISH PANEL SUB-ASSEMBLY_ [INFO](#)

23. REMOVE INSTRUMENT CLUSTER FINISH PANEL GARNISH_ [INFO](#)

24. REMOVE UPPER INSTRUMENT PANEL FINISH PANEL SUB-ASSEMBLY_ [INFO](#)

25. REMOVE RADIO RECEIVER WITH BRACKET (w/o Navigation System)_ [INFO](#)

26. REMOVE NAVIGATION RECEIVER WITH BRACKET (w/ Navigation System)_ [INFO](#)

27. REMOVE FRONT DOOR SCUFF PLATE LH_ [INFO](#)

28. REMOVE COWL SIDE TRIM SUB-ASSEMBLY LH_ [INFO](#)

29. REMOVE LOWER INSTRUMENT PANEL FINISH PANEL ASSEMBLY_ [INFO](#)

30. REMOVE NO. 1 INSTRUMENT PANEL REGISTER_ [INFO](#)

31. REMOVE NO. 1 CENTER INSTRUMENT CLUSTER FINISH PANEL_ [INFO](#)

32. DISCONNECT FRONT DOOR OPENING TRIM WEATHERSTRIP LH_ [INFO](#)

33. REMOVE INSTRUMENT PANEL FINISH PANEL END LH_ [INFO](#)

34. REMOVE NO. 1 SIDE DEFROSTER NOZZLE_ [INFO](#)

35. REMOVE NO. 2 INSTRUMENT PANEL REGISTER_ [INFO](#)

36. REMOVE GLOVE COMPARTMENT DOOR_ [INFO](#)

37. REMOVE FRONT DOOR OPENING TRIM WEATHERSTRIP RH

HINT:

Use the same procedure for the RH side and LH side.

38. REMOVE INSTRUMENT PANEL FINISH PANEL END RH_ [INFO](#)

39. REMOVE FRONT PILLAR GARNISH LH_ [INFO](#)

40. REMOVE FRONT PILLAR GARNISH CORNER PIECE LH_ [INFO](#)

41. REMOVE NO. 1 INSTRUMENT PANEL SPEAKER PANEL SUB-ASSEMBLY_ [INFO](#)

42. REMOVE FRONT NO. 2 SPEAKER ASSEMBLY_ [INFO](#)

43. REMOVE FRONT PILLAR GARNISH RH

HINT:

Use the same procedure for the RH side and LH side.

44. REMOVE FRONT PILLAR GARNISH CORNER PIECE RH_ [INFO](#)

45. REMOVE NO. 2 INSTRUMENT PANEL SPEAKER PANEL SUB-ASSEMBLY_ [INFO](#)

46. REMOVE FRONT NO. 2 SPEAKER ASSEMBLY

HINT:

Use the same procedure for the RH side and LH side.

47. REMOVE CENTER INSTRUMENT CLUSTER FINISH PANEL GARNISH_ [INFO](#)

48. DISCONNECT INSTRUMENT PANEL WIRE_ [INFO](#)

49. REMOVE UPPER INSTRUMENT PANEL ASSEMBLY_ [INFO](#)

50. REMOVE REAR CONSOLE BOX POCKET (w/ Power Outlet Socket)_ [INFO](#)

51. REMOVE UPPER CONSOLE PANEL (w/ Power Outlet Socket)_ [INFO](#)

52. REMOVE CONSOLE BOX CARPET_ [INFO](#)

53. REMOVE REAR CONSOLE BOX ASSEMBLY (w/ Power Outlet Socket)_ [INFO](#)

54. REMOVE REAR CONSOLE BOX ASSEMBLY (w/o Power Outlet Socket)_ [INFO](#)

55. REMOVE ELECTRICAL KEY OSCILLATOR_ [INFO](#)

56. REMOVE NO. 2 CONSOLE BOX MOUNTING BRACKET_ [INFO](#)
57. REMOVE FRONT NO. 1 CONSOLE BOX INSERT_ [INFO](#)
58. REMOVE FRONT NO. 2 CONSOLE BOX INSERT_ [INFO](#)
59. REMOVE BOX BOTTOM MAT_ [INFO](#)
60. SEPARATE CONSOLE BOX ASSEMBLY_ [INFO](#)
61. REMOVE AIR CONDITIONING CONTROL ASSEMBLY_ [INFO](#)
62. REMOVE SHIFT LOCK CONTROL UNIT ASSEMBLY_ [INFO](#)
63. REMOVE UPPER INSTRUMENT PANEL FINISH PANEL ASSEMBLY_ [INFO](#)
64. REMOVE CONSOLE BOX ASSEMBLY_ [INFO](#)
65. REMOVE NO. 1 SWITCH HOLE BASE_ [INFO](#)
66. REMOVE LOWER NO. 3 STEERING WHEEL COVER_ [INFO](#)
67. REMOVE LOWER NO. 2 STEERING WHEEL COVER_ [INFO](#)
68. REMOVE STEERING PAD_ [INFO](#)
69. REMOVE STEERING WHEEL ASSEMBLY_ [INFO](#)
70. REMOVE LOWER STEERING COLUMN COVER_ [INFO](#)
71. REMOVE UPPER STEERING COLUMN COVER_ [INFO](#)
72. REMOVE TURN SIGNAL SWITCH ASSEMBLY WITH SPIRAL CABLE SUB-ASSEMBLY_ [INFO](#)
73. REMOVE NO. 1 INSTRUMENT PANEL UNDER COVER SUB-ASSEMBLY_ [INFO](#)
74. REMOVE DRIVER SIDE KNEE AIRBAG ASSEMBLY_ [INFO](#)
75. REMOVE NO. 2 INSTRUMENT PANEL UNDER COVER SUB-ASSEMBLY_ [INFO](#)
76. REMOVE GLOVE COMPARTMENT DOOR ASSEMBLY_ [INFO](#)
77. REMOVE FRONT DOOR SCUFF PLATE RH

HINT:

Use the same procedure for the RH side and LH side.

78. REMOVE COWL SIDE TRIM BOARD RH

HINT:

Use the same procedure for the RH side and LH side.

79. REMOVE NO. 1 HEATER TO REGISTER DUCT_ [INFO](#)

80. REMOVE COMBINATION METER ASSEMBLY_ [INFO](#)

81. REMOVE POWER STEERING ECU ASSEMBLY (for Brush Type Motor)_ [INFO](#)

82. REMOVE POWER STEERING ECU ASSEMBLY (for Brushless Type Motor)_ [INFO](#)

83. REMOVE INSTRUMENT PANEL SAFETY PAD PLATE SUB-ASSEMBLY (for LHD)_ [INFO](#)

84. REMOVE NO. 2 ANTENNA CORD SUB-ASSEMBLY_ [INFO](#)

85. REMOVE LOWER INSTRUMENT PANEL SUB-ASSEMBLY_ [INFO](#)

86. REMOVE DRIVER SIDE JUNCTION BLOCK ASSEMBLY_ [INFO](#)

87. REMOVE STOP LIGHT SWITCH ASSEMBLY_ [INFO](#)

88. REMOVE STOP LIGHT SWITCH MOUNTING ADJUSTER

89. REMOVE BRAKE PEDAL RETURN SPRING_ [INFO](#)

90. REMOVE PUSH ROD PIN_ [INFO](#)

91. REMOVE BRAKE PEDAL SUPPORT ASSEMBLY_ [INFO](#)

92. REMOVE NO. 2 AIR DUCT SUB-ASSEMBLY_ [INFO](#)

93. REMOVE COLUMN HOLE COVER SILENCER SHEET_ [INFO](#)

94. SEPARATE NO. 2 STEERING INTERMEDIATE SHAFT ASSEMBLY_ [INFO](#)

95. REMOVE STEERING POST ASSEMBLY

for Brush Type Motor: [INFO](#)

for Brushless Type Motor: [INFO](#)

96. REMOVE REAR NO. 2 AIR DUCT (w/ Rear Air Duct)

(a) Disengage each claw to open the 2 door scuff plate clamps as shown in the illustration.

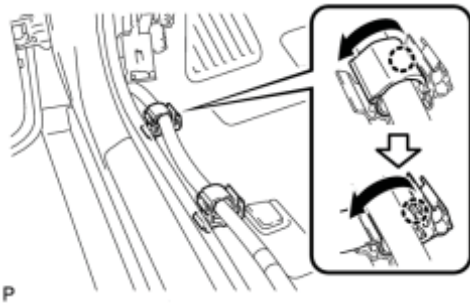

P

(b) Disengage the clip and fastener.

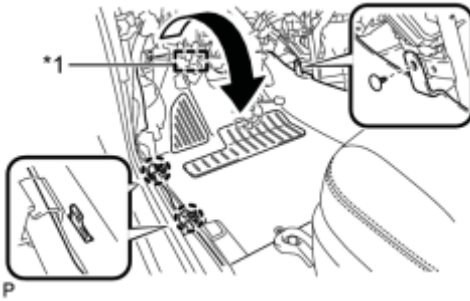

P

(c) Disengage the 2 claws and turn back the floor carpet as shown in the illustration.

Text in Illustration

*1	Fastener
----	----------

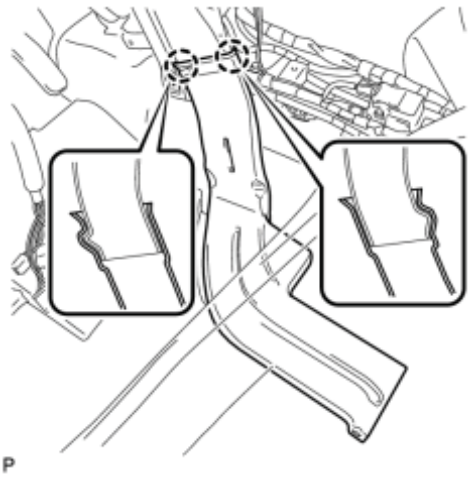

(d) Disengage the 2 claws and remove the rear No. 2 air duct.

97. REMOVE REAR NO. 3 AIR DUCT (w/ Rear Air Duct)

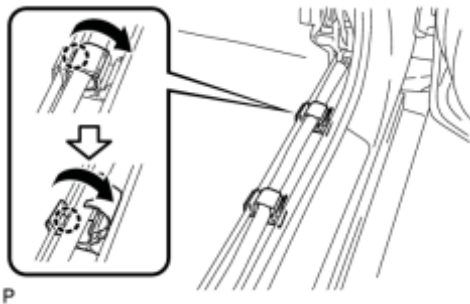

(a) Disengage each claw to open the 2 door scuff plate clamps as shown in the illustration.



(b) Disengage the clip and fastener.

(c) Disengage the 2 claws and turn back the floor carpet as shown in the illustration.

Text in Illustration

*1	Fastener
----	----------

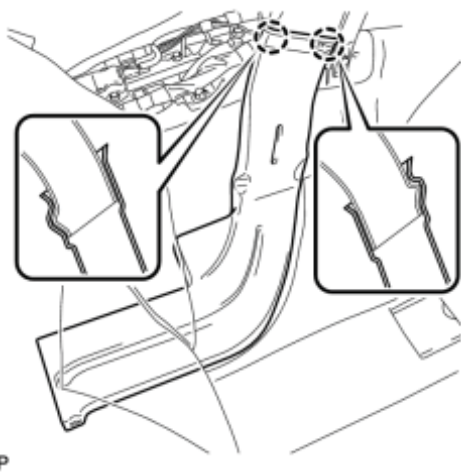

(d) Disengage the 2 claws and remove the rear No. 3 air duct.

98. REMOVE REAR NO. 1 AIR DUCT (w/ Rear Air Duct)

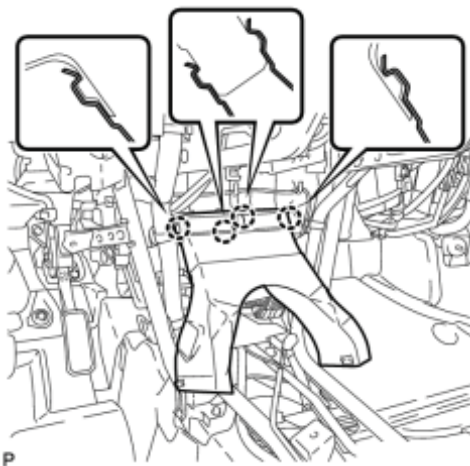

(a) Disengage the 4 claws and remove the rear No. 1 air duct.

99. REMOVE NO. 3 SIDE DEFROSTER NOZZLE DUCT

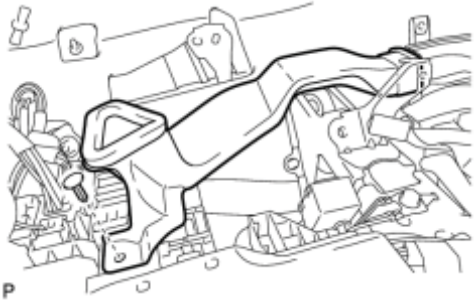

(a) Remove the clip and No. 3 side defroster nozzle duct.

100. REMOVE NO. 1 INSTRUMENT PANEL BRACE SUB-ASSEMBLY

- (a) Check that the power switch is off.
- (b) Check that the cable is disconnected from the negative (-) battery terminal.

CAUTION:

Wait at least 90 seconds after disconnecting the cable from the negative (-) battery terminal to disable the SRS system.

- (c) Disconnect the center airbag sensor connectors from the center airbag sensor assembly as shown in the illustration.

NOTICE:

When disconnecting any airbag connector, take care not to damage the airbag wire harness.

- (d) Remove the screw.
- (e) Remove the 2 bolts and disconnect the 2 earth wires.
- (f) Disconnect each connector.
- (g) Disengage each clamp and claw.

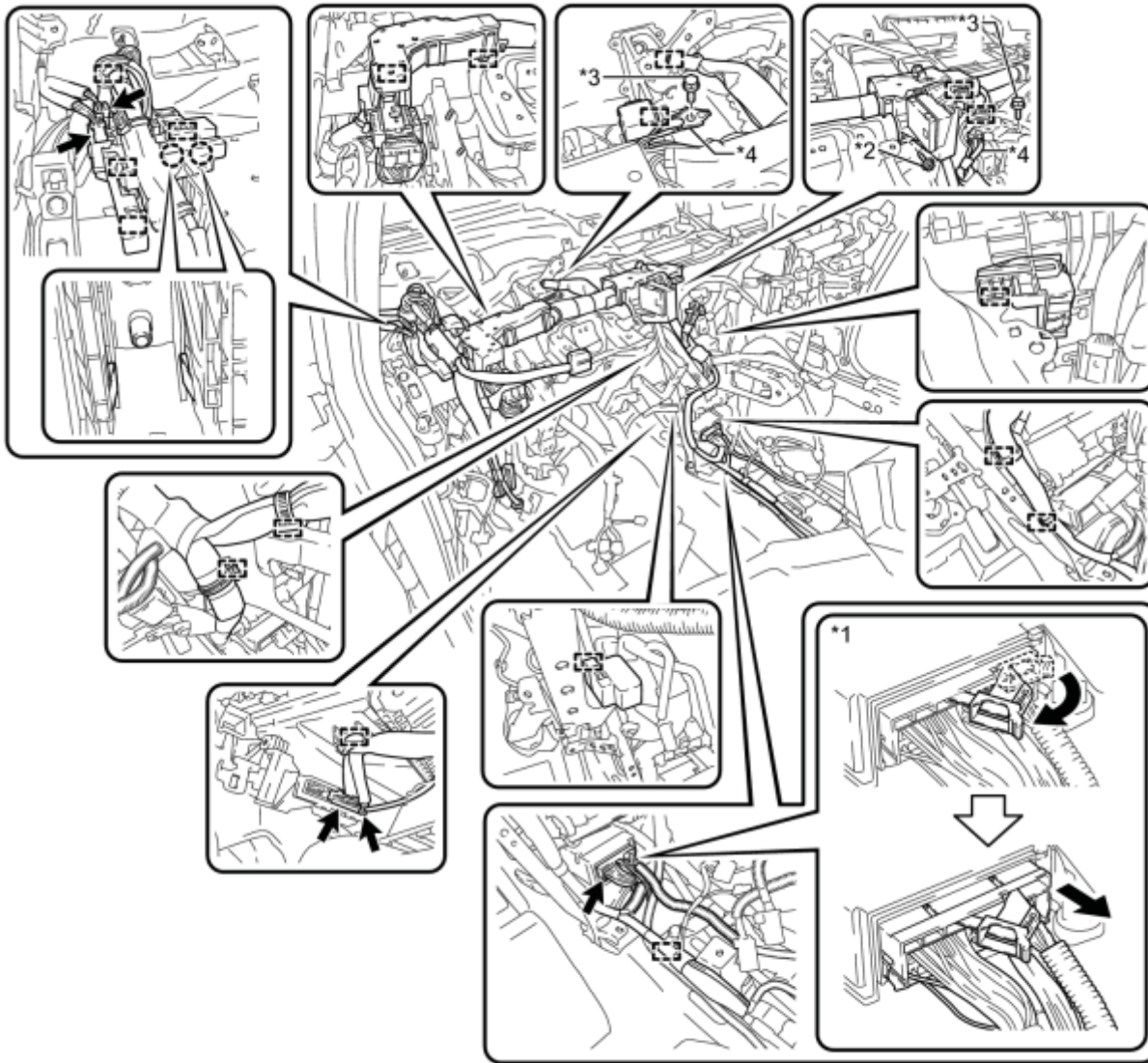

P

Text in Illustration

*1	Center Airbag Sensor Connector	*2	Screw
*3	Bolt	*4	Earth Wire

(h) Remove the screw.

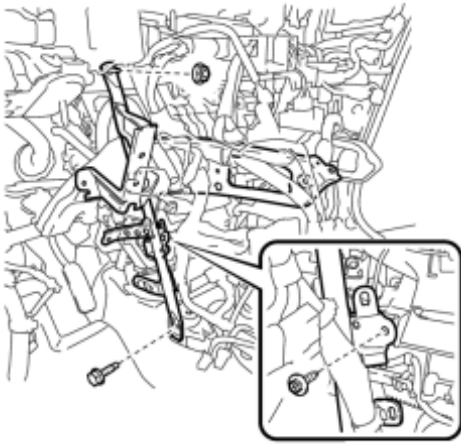

P

(i) Remove the bolt, nut and No. 1 instrument panel brace sub-assembly.

101. REMOVE NO. 2 INSTRUMENT PANEL BRACE SUB-ASSEMBLY

(a) Remove the 3 screws <A>.

(b) Remove the bolt and disconnect the earth wire.

(c) Disconnect each connector.

(d) Disengage each clamp.

(e) Remove the screw and 2 nuts from the computer integration box RH.

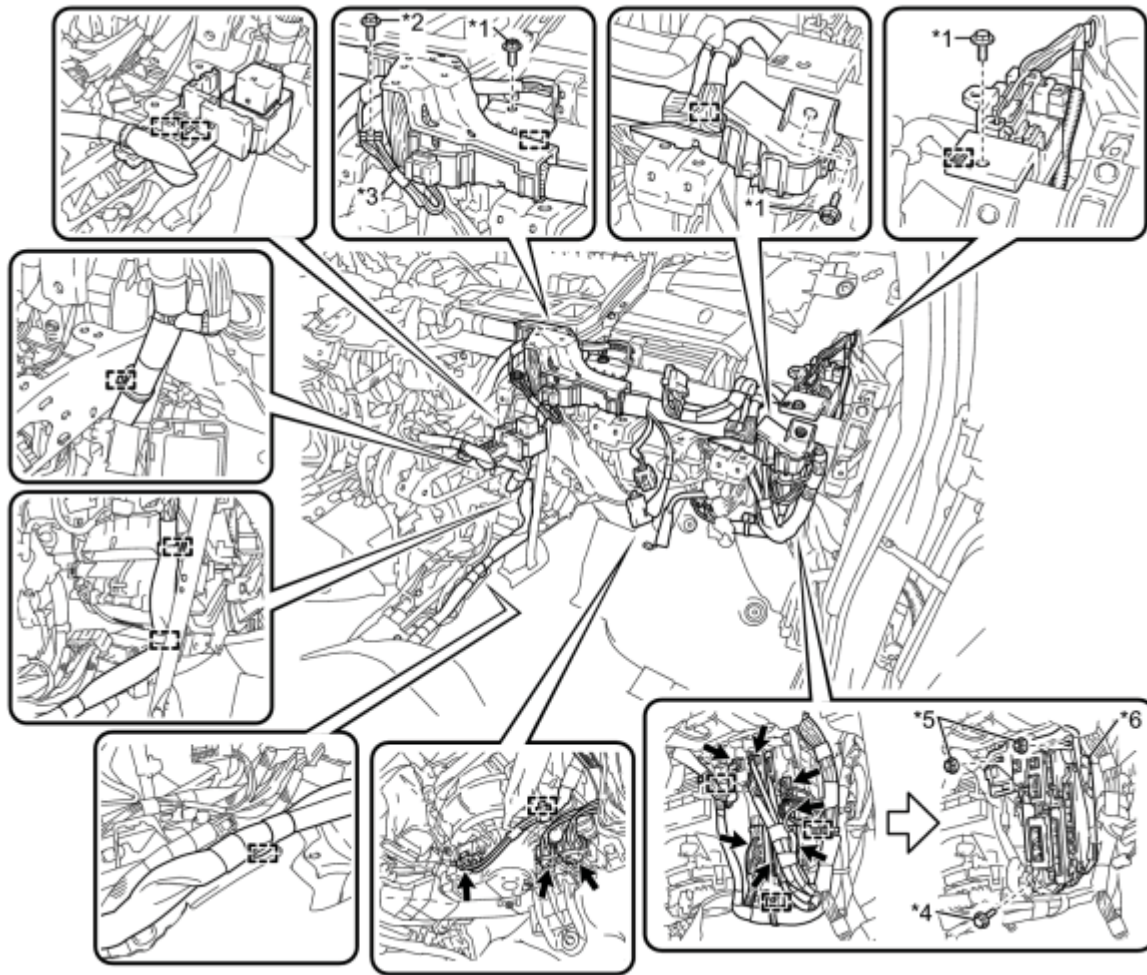

P

Text in Illustration

*1	Screw <A>	*2	Bolt
*3	Earth Wire	*4	Screw
*5	Nut	*6	Computer Integration Box RH

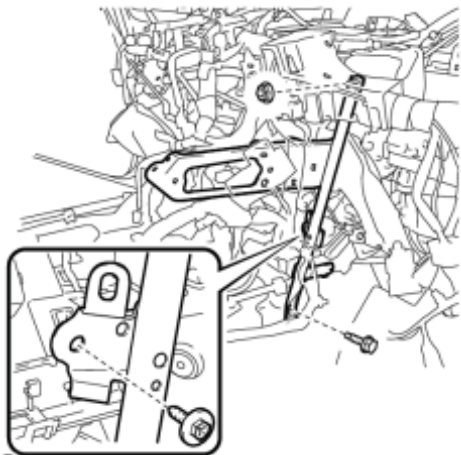

P

(f) Remove the screw.

(g) Remove the bolt, nut and No. 2 instrument panel brace sub-assembly.

102. REMOVE DEFROSTER NOZZLE ASSEMBLY

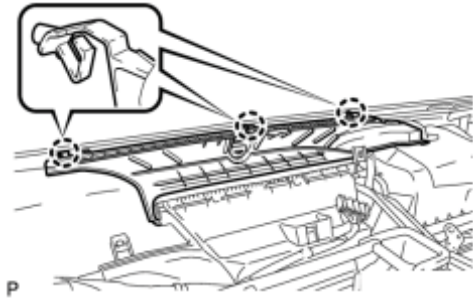

(a) Disengage the 3 claws.

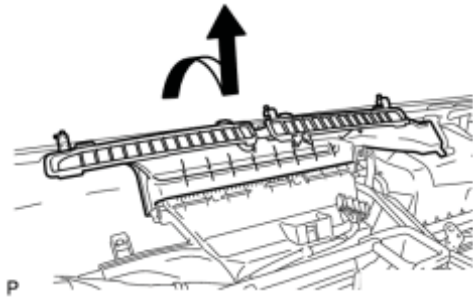

(b) Remove the defroster nozzle assembly as shown in the illustration.

103. REMOVE LOWER DEFROSTER NOZZLE ASSEMBLY

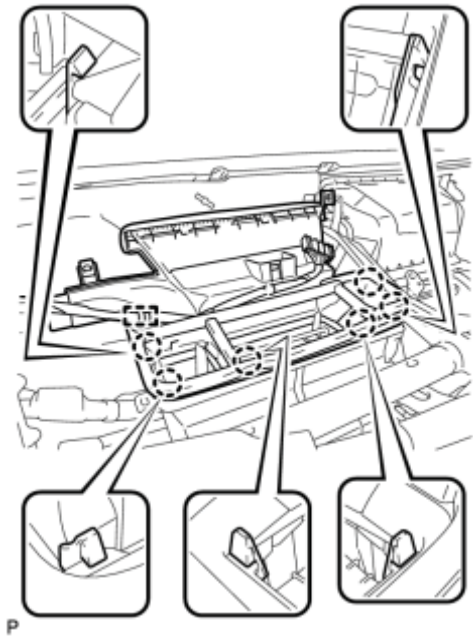

(a) Disengage the clamp.

(b) Disengage the 6 claws and remove the lower defroster nozzle assembly.

104. REMOVE NO. 3 AIR DUCT SUB-ASSEMBLY

(a) Remove the 2 nuts and No. 3 air duct sub-assembly.

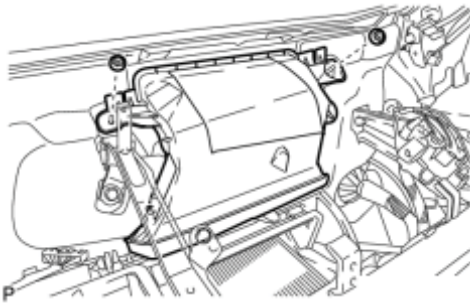

105. REMOVE INSTRUMENT PANEL REINFORCEMENT ASSEMBLY

(a) Disengage each clamp.

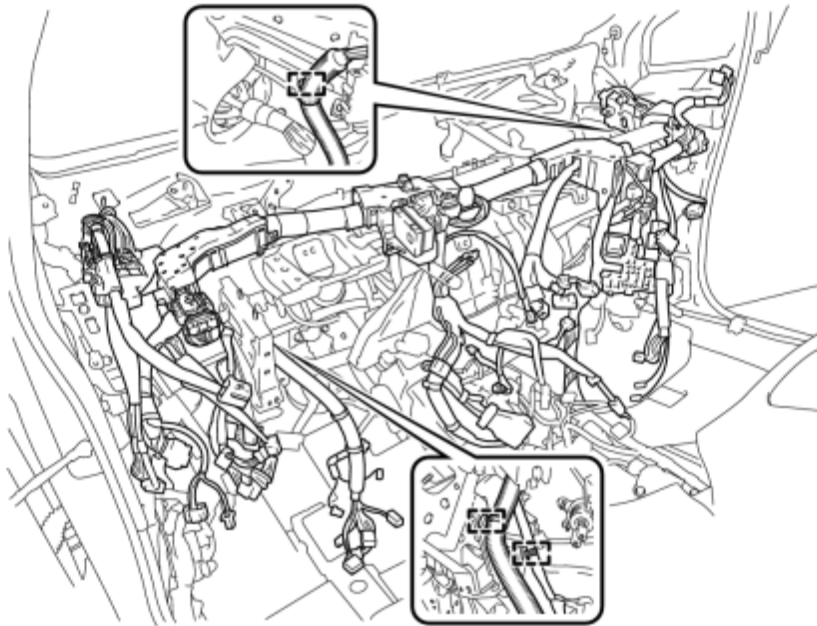

(b) Remove the 9 bolts and instrument panel reinforcement assembly.

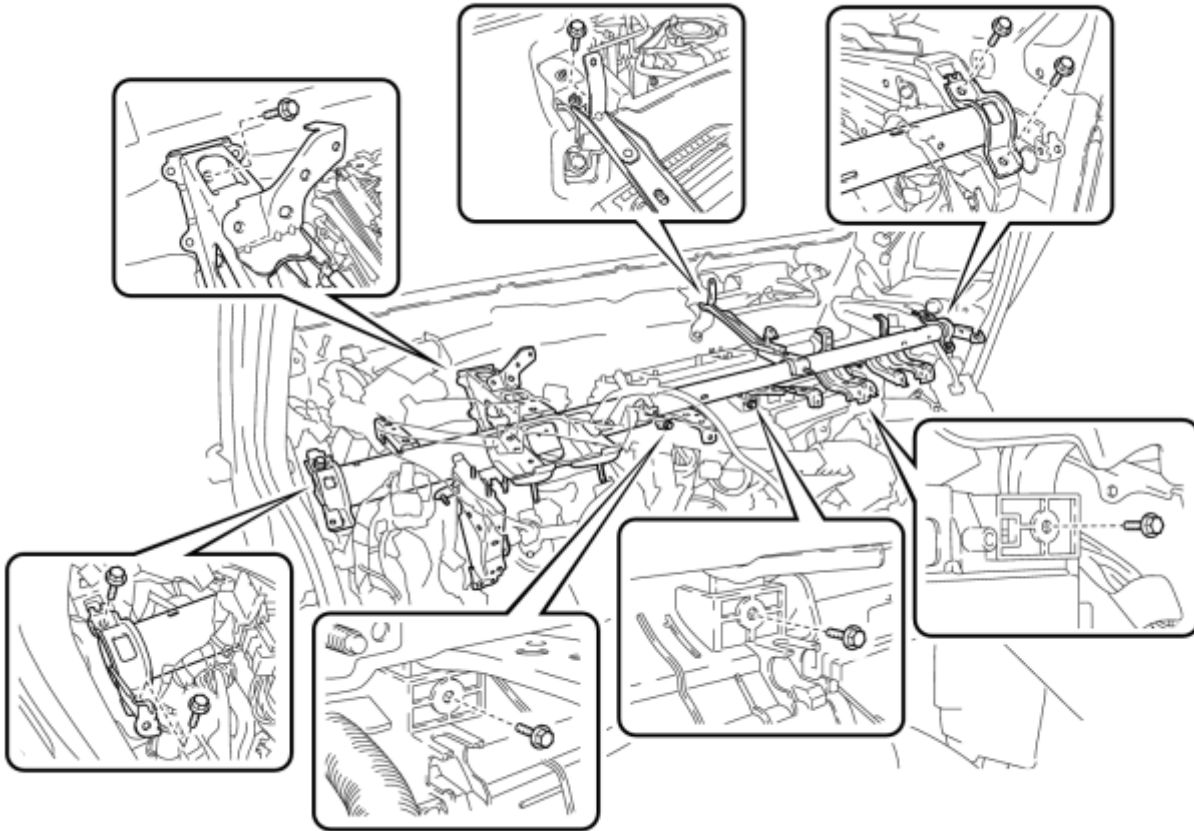

P

106. REMOVE AIR CONDITIONING UNIT ASSEMBLY

NOTICE:

- Be sure to support the air conditioning unit assembly when removing it because failure to do so may cause the bracket of the air conditioning unit assembly to break.
- When disassembling the air conditioning unit, eliminate static electricity by touching the vehicle body to prevent the components from being damaged.

(a) Disengage the cooler drain hose.

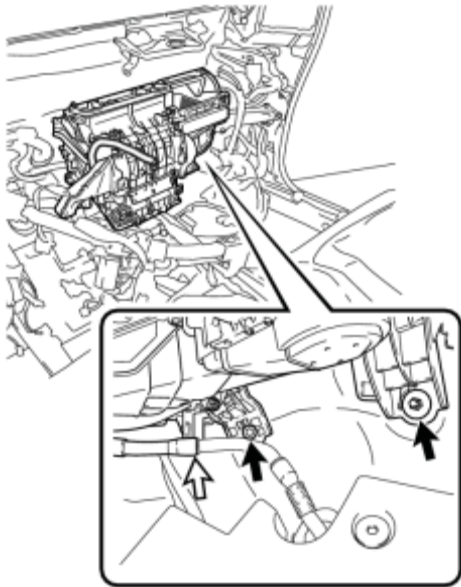

P

(b) Remove the bolt, nut and air conditioning unit assembly.

DISASSEMBLY

1. REMOVE ID CODE BOX (IMMOBILISER CODE ECU) (w/ Engine Immobiliser System) INFO

2. REMOVE BLOWER ASSEMBLY INFO

3. REMOVE NO. 1 AIR DUCT SUB-ASSEMBLY

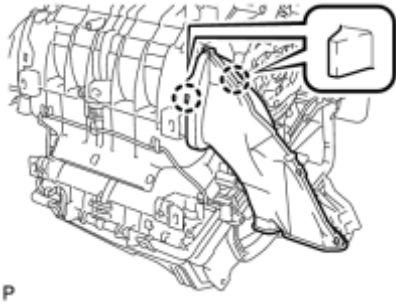

(a) Disengage the 2 claws and remove the No. 1 air duct sub-assembly.

4. REMOVE AIR CONDITIONING DUCT SUB-ASSEMBLY

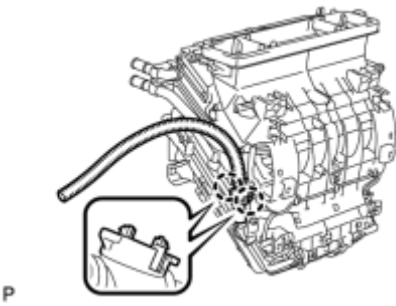

(a) Disengage the 2 claws and remove the air conditioning duct sub-assembly.

5. REMOVE AIR CONDITIONING HARNESS ASSEMBLY

(a) Disconnect each connector.

(b) Disengage each clamp and remove the air conditioning harness assembly.

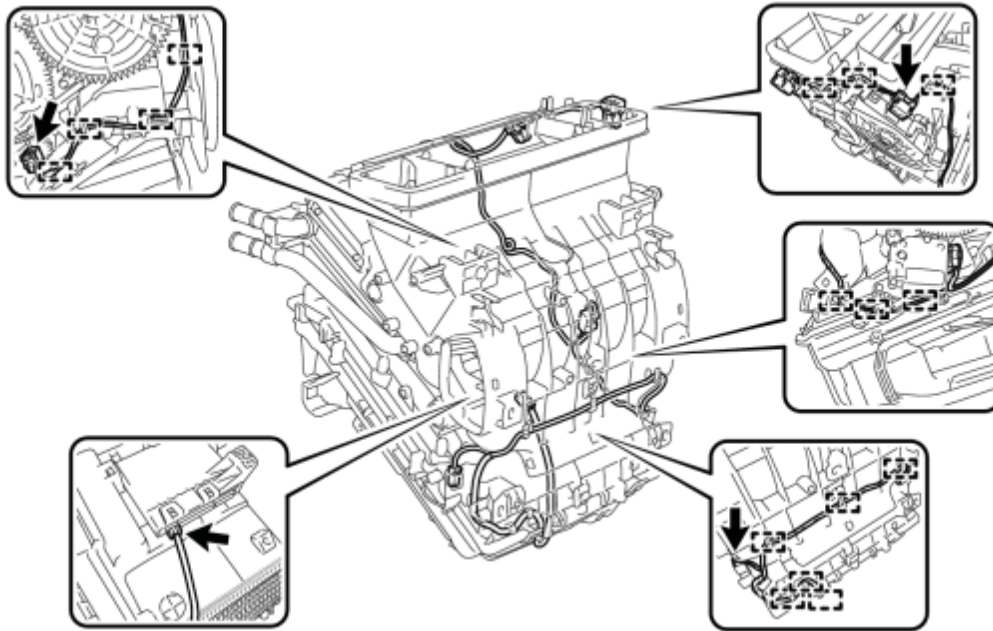

6. REMOVE AIR OUTLET CONTROL SERVO MOTOR SUB-ASSEMBLY

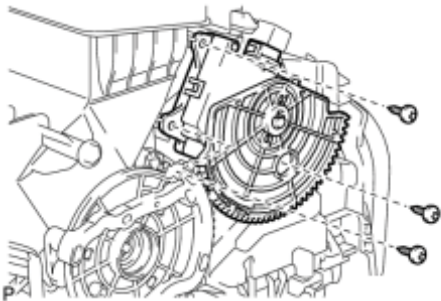

(a) Remove the 3 screws and air outlet control servo motor sub-assembly.

7. REMOVE AIR MIX CONTROL SERVO MOTOR SUB-ASSEMBLY

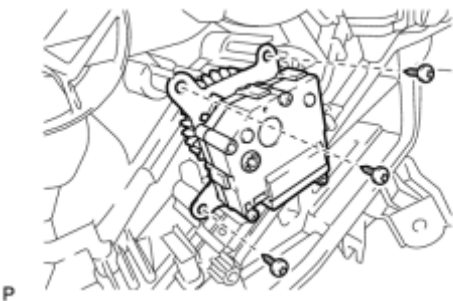

(a) Remove the 3 screws and air mix control servo motor sub-assembly.

8. REMOVE QUICK HEATER ASSEMBLY

(a) Disengage each clamp.

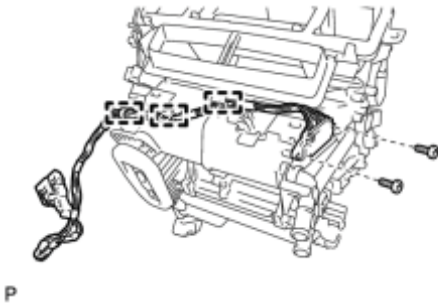

(b) Remove the 2 screws.

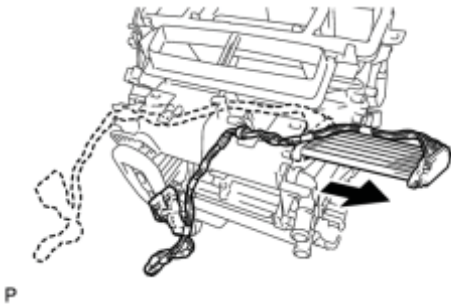

(c) Remove the quick heater assembly as shown in the illustration.

9. REMOVE HEATER RADIATOR UNIT SUB-ASSEMBLY

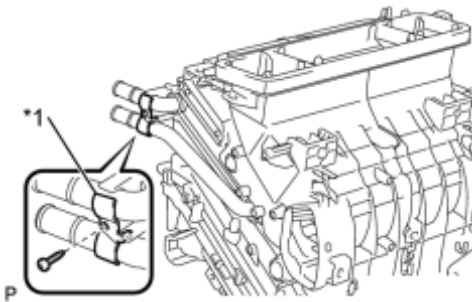

(a) Remove the screw and clamp.

Text in Illustration

*1	Clamp
----	-------

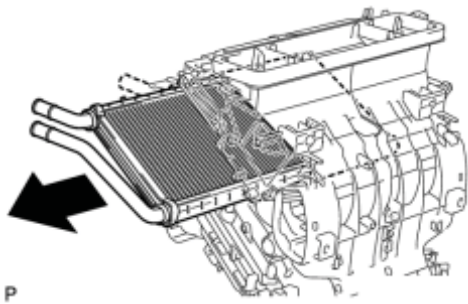

(b) Remove the heater radiator unit sub-assembly as shown in the illustration.

NOTICE:

Prepare a drain pan or cloth in case the cooling water leaks.

10. REMOVE CONSOLE MOUNTING BRACKET LH

(a) Remove the screw and console mounting bracket LH.

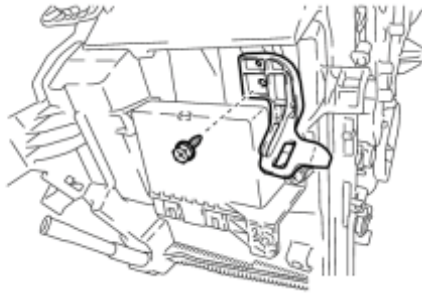

P

11. REMOVE AIR CONDITIONING AMPLIFIER ASSEMBLY

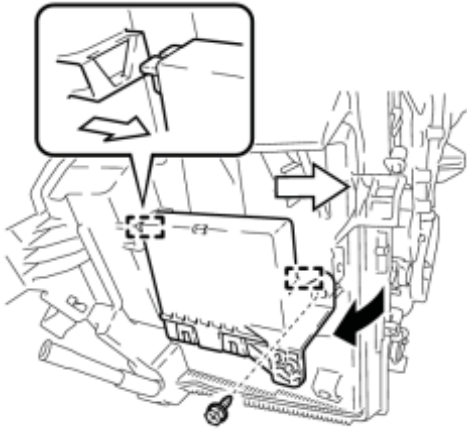

P

(a) Remove the screw.

(b) Disengage the 2 guides and remove the air conditioning amplifier assembly as shown in the illustration.

12. REMOVE CONSOLE MOUNTING BRACKET RH

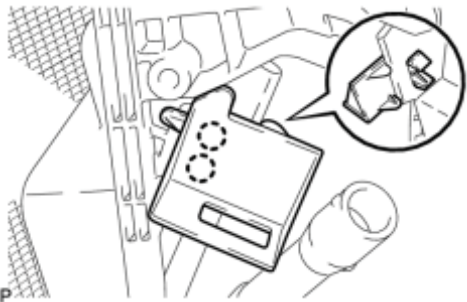

P

(a) Disengage the 2 claws and remove the console mounting bracket RH.

13. REMOVE DRAIN COOLER HOSE

(a) Remove the drain cooler hose as shown in the illustration.

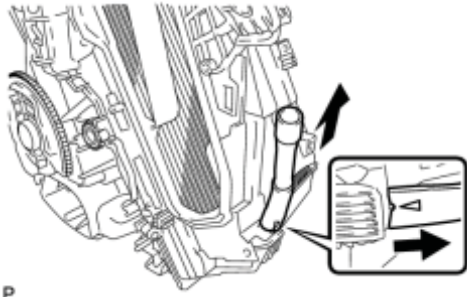

14. REMOVE COOLER EXPANSION VALVE

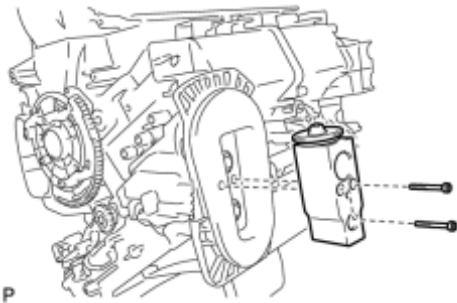

(a) Using a 4 mm hexagon wrench, remove the 2 hexagon bolts and cooler expansion valve.

15. REMOVE COOLER EVAPORATOR SUB-ASSEMBLY

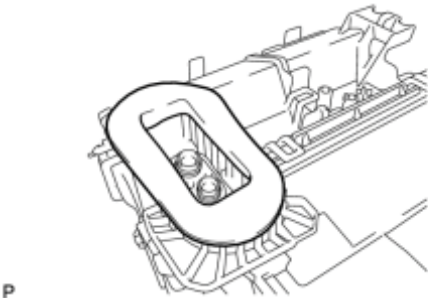

(a) Remove the packing.

NOTICE:

Remove the packing carefully because it will be reused.

(b) Remove the 4 screws.

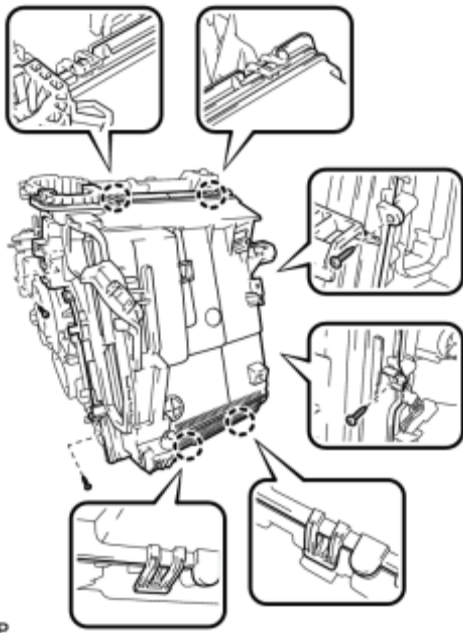

P

(c) Disengage the 4 claws and remove the lower heater case.

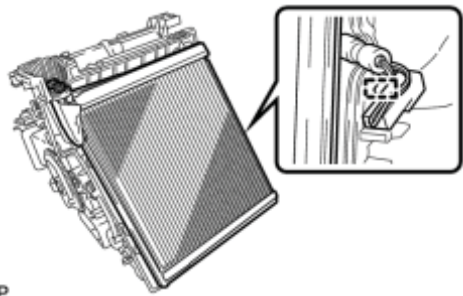

P

(d) Disengage the clamp and remove the cooler evaporator sub-assembly with the No. 1 cooler thermistor.

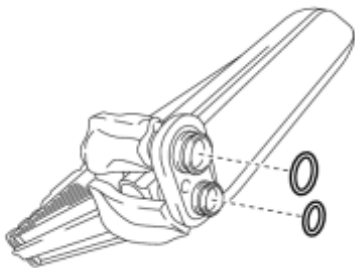

P

(e) Remove the 2 O-rings from the cooler evaporator sub-assembly.

16. REMOVE NO. 1 COOLER THERMISTOR_ INFO

REASSEMBLY

1. INSTALL NO. 1 COOLER THERMISTOR_ INFO

2. INSTALL COOLER EVAPORATOR SUB-ASSEMBLY

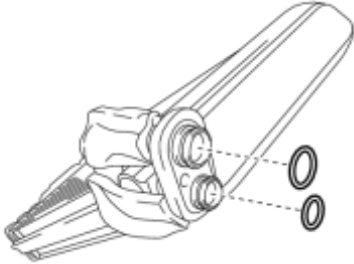

(a) Sufficiently apply compressor oil to 2 new O-rings and the fitting surfaces.

Compressor oil:

ND-OIL 11 or equivalent

(b) Install the 2 O-rings to the cooler evaporator sub-assembly.

NOTICE:

- Keep the O-rings and O-ring fitting surfaces free from dirt or any foreign objects.
- Do not use any compressor oil other than ND-OIL 11 or equivalent. If any compressor oil other than ND-OIL 11 or equivalent is used, compressor motor insulation performance may decrease, resulting in a leakage of electric power.

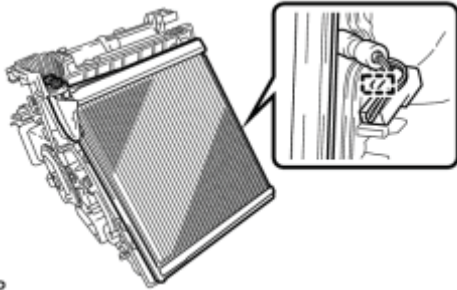

(c) Engage the clamp and install the cooler evaporator sub-assembly with the No. 1 cooler thermistor.

HINT:

Completely cover the tube with the grommet.

(d) Engage the 4 claws.

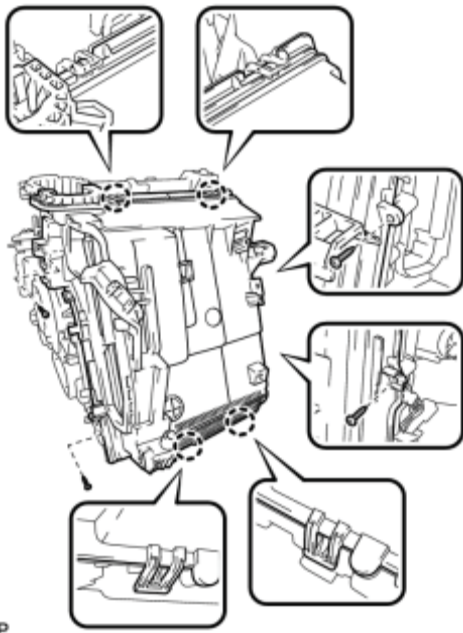

P

(e) Install the lower heater case with the 4 screws.

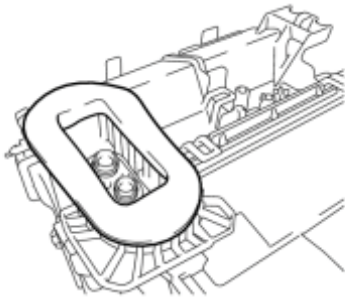

P

(f) Install the packing.

3. INSTALL COOLER EXPANSION VALVE

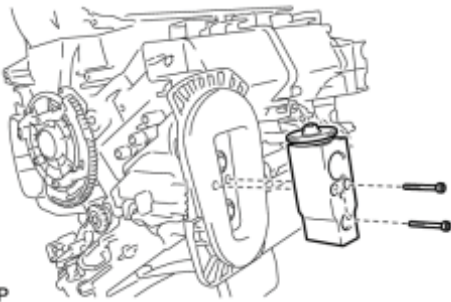

P

(a) Using a 4 mm hexagon wrench, install the cooler expansion valve with the 2 hexagon bolts.

Torque: **3.5 N·m (36 kgf·cm, 31 in·lbf)**

4. INSTALL DRAIN COOLER HOSE

(a) Install the drain cooler hose as shown in the illustration.

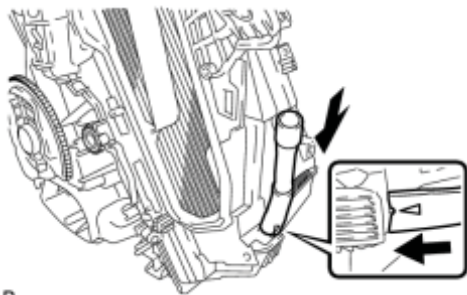

P

5. INSTALL CONSOLE MOUNTING BRACKET RH



P

(a) Engage the 2 claws and install the console mounting bracket RH.

6. INSTALL AIR CONDITIONING AMPLIFIER ASSEMBLY

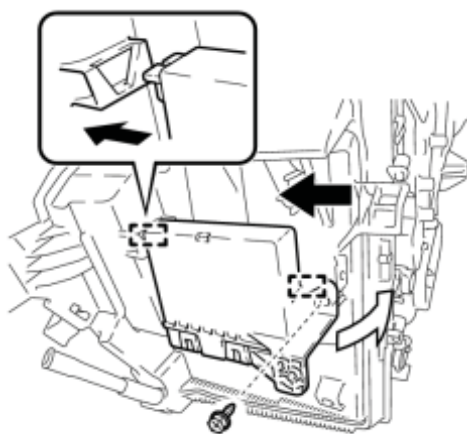

P

(a) Engage the 2 guides to install the air conditioning amplifier assembly as shown in the illustration.

(b) Install the screw.

7. INSTALL CONSOLE MOUNTING BRACKET LH

(a) Install the console mounting bracket LH with the screw.

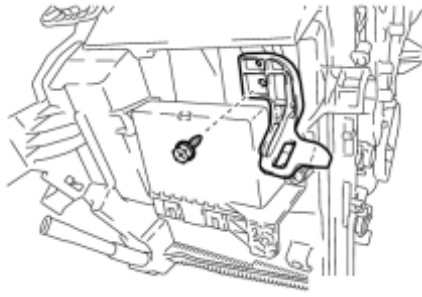

P

8. INSTALL HEATER RADIATOR UNIT SUB-ASSEMBLY

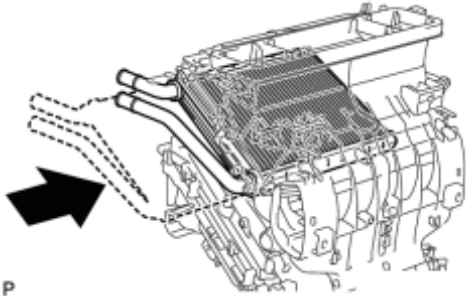

P

(a) Install the heater radiator unit sub-assembly as shown in the illustration.

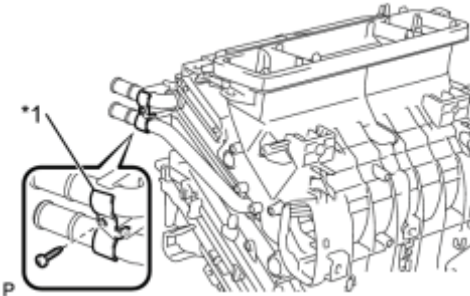

P

(b) Install the clamp with the screw.

Text in Illustration

*1	Clamp
----	-------

9. INSTALL QUICK HEATER ASSEMBLY

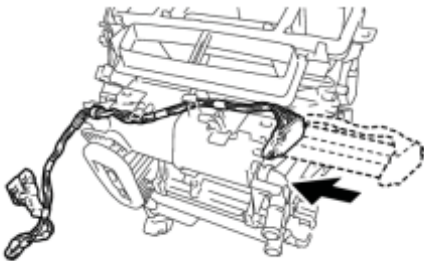

P

(a) Install the quick heater assembly as shown in the illustration.

(b) Install the 2 screws.

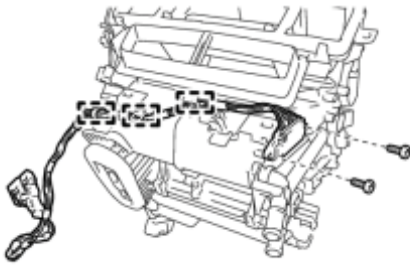

P

(c) Engage each clamp.

10. INSTALL AIR MIX CONTROL SERVO MOTOR SUB-ASSEMBLY

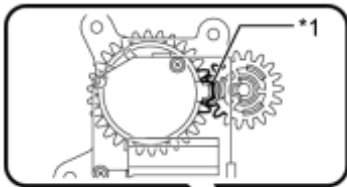

(a) Using the reference point, install the air mix control servo motor sub-assembly with the 3 screws.

Text in Illustration

*1	Reference Point
----	-----------------

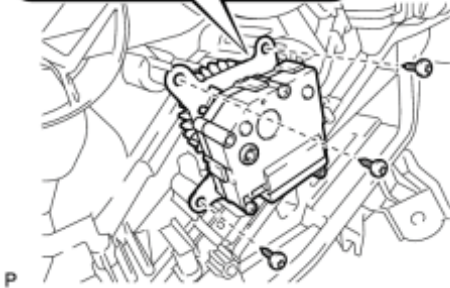

P

11. INSTALL AIR OUTLET CONTROL SERVO MOTOR SUB-ASSEMBLY

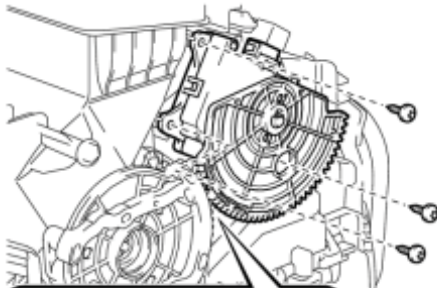

(a) Using the reference point, install the air outlet control servo motor sub-assembly with the 3 screws.

Text in Illustration

*1	Reference Point
----	-----------------

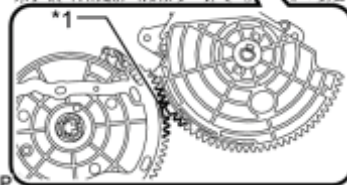

P

12. INSTALL AIR CONDITIONING HARNESS ASSEMBLY

(a) Connect each connector.

(b) Engage each clamp to install the air conditioning harness assembly.

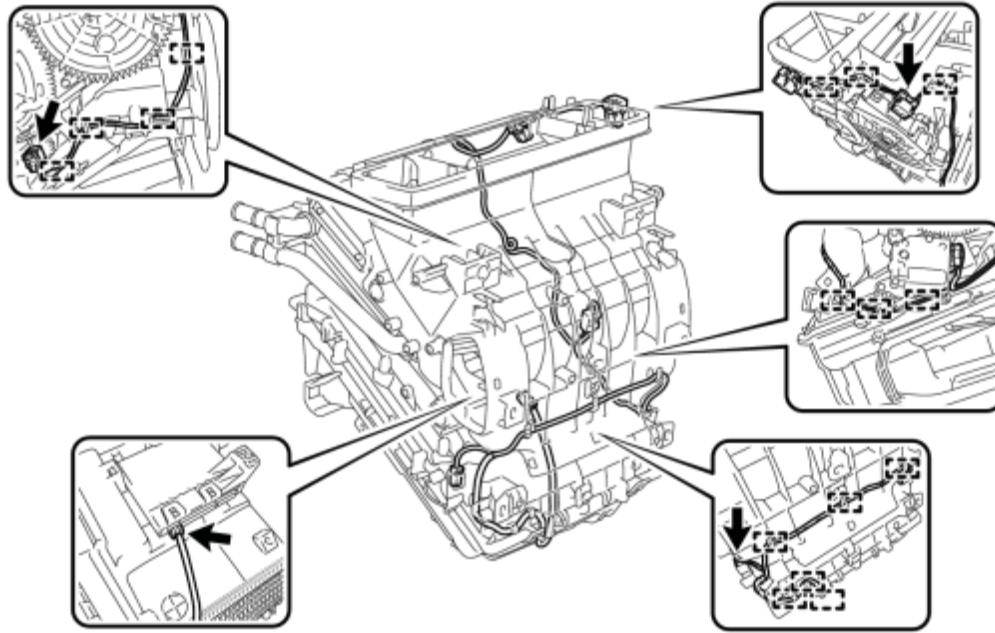

P

13. INSTALL AIR CONDITIONING DUCT SUB-ASSEMBLY

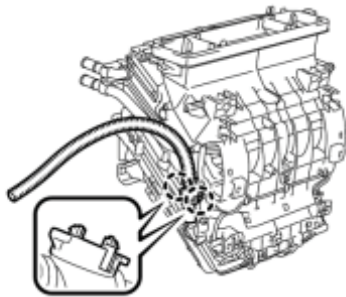

P

(a) Engage the 2 claws and install the air conditioning duct sub-assembly.

14. INSTALL NO. 1 AIR DUCT SUB-ASSEMBLY

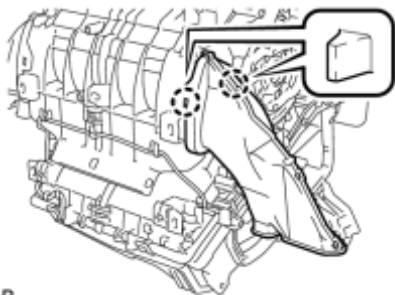

P

(a) Engage the 2 claws to install the No. 1 air duct sub-assembly.

15. INSTALL BLOWER ASSEMBLY_ INFO

16. INSTALL ID CODE BOX (IMMOBILISER CODE ECU) (w/ Engine Immobiliser System)_ INFO

INSTALLATION

1. TEMPORARILY TIGHTEN AIR CONDITIONING UNIT ASSEMBLY

NOTICE:

- Be sure to support the air conditioning unit assembly when removing it because failure to do so may cause the bracket of the air conditioning unit assembly to break.
- When installing the air conditioning unit, eliminate static electricity by touching the vehicle body to prevent the components from being damaged.

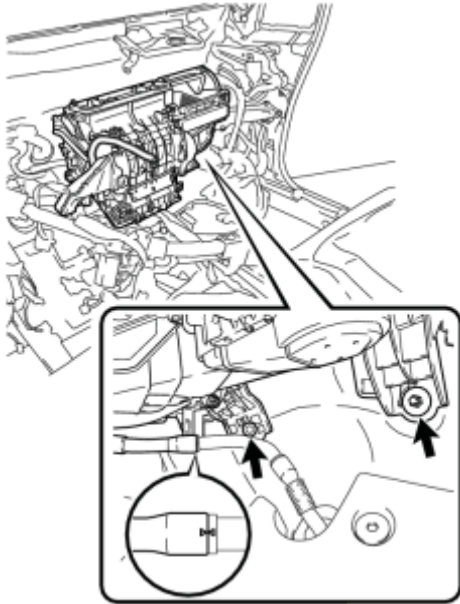

(a) Temporarily tighten the air conditioning unit assembly with the bolt and nut.

P

(b) Engage the cooler drain hose as shown in the illustration.

NOTICE:

Connect the cooler drain hose firmly to prevent water leaks.

2. INSTALL INSTRUMENT PANEL REINFORCEMENT ASSEMBLY

(a) Install the instrument panel reinforcement assembly with the 6 bolts <A>.

(b) Install the air conditioning unit assembly with the 3 bolts

Bolt - Torque: **9.8 N·m (100 kgf·cm, 87in·lbf)**

HINT:

Tighten the bolts in the order shown in the illustration.

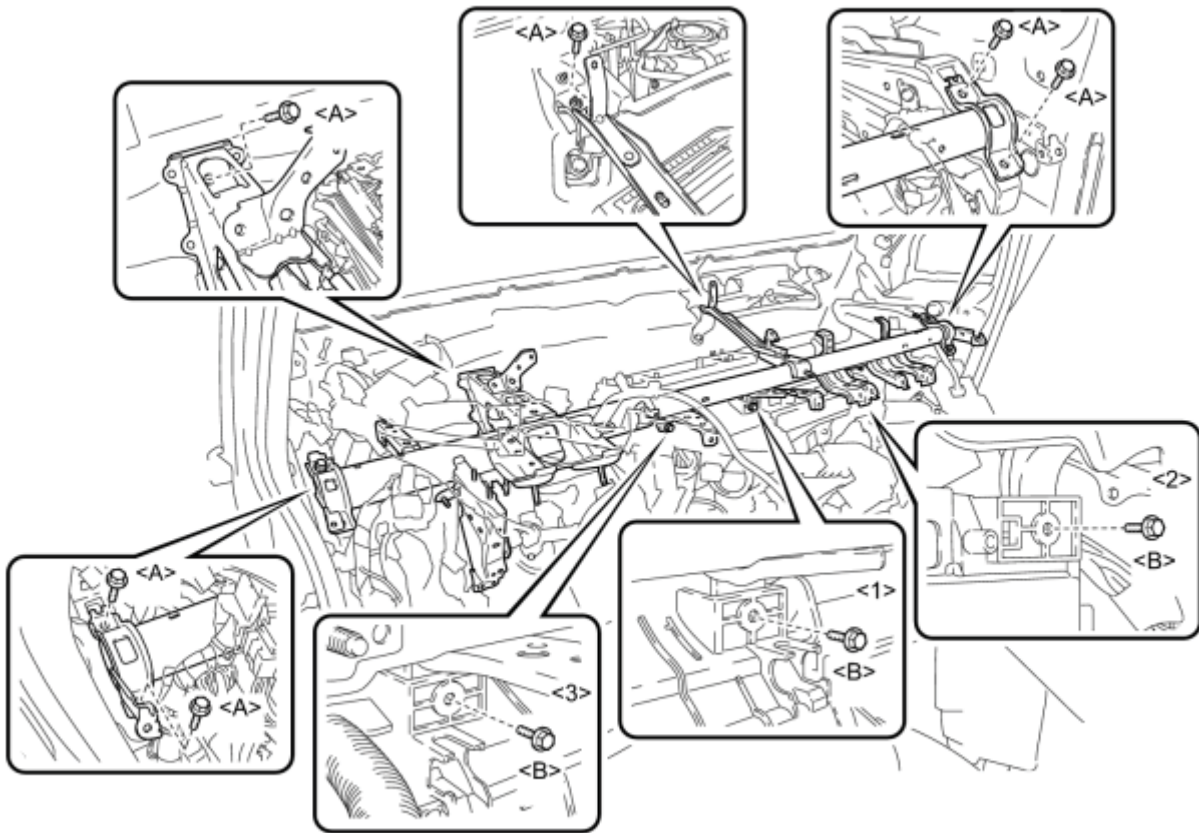

P

(c) Engage each clamp.

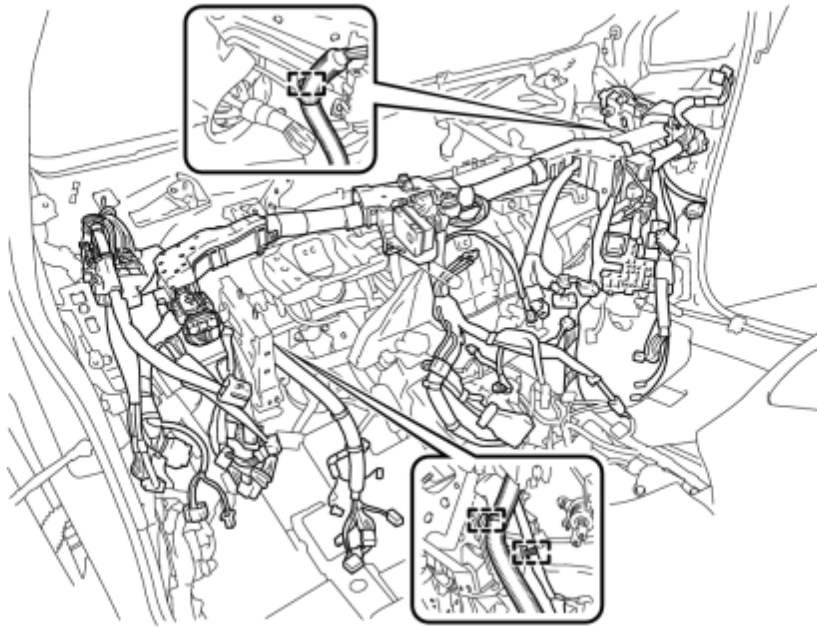

P

3. INSTALL AIR CONDITIONING UNIT ASSEMBLY

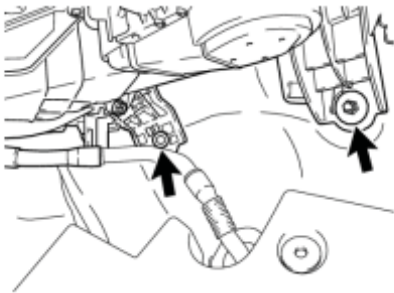

P

(a) Install the air conditioning unit assembly with the bolt and nut.

Bolt - Torque: **9.8 N·m (100 kgf·cm, 87in·lbf)**

Nut - Torque: **9.8 N·m (100 kgf·cm, 87in·lbf)**

4. INSTALL NO. 3 AIR DUCT SUB-ASSEMBLY

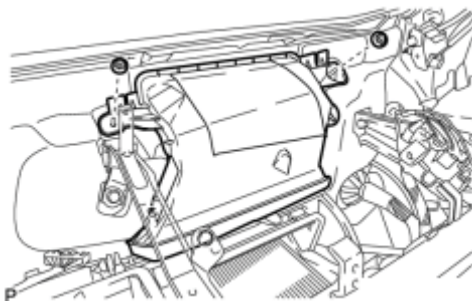

P

(a) Install the No. 3 air duct sub-assembly with the 2 nuts.

Torque: **9.8 N·m (100 kgf·cm, 87in·lbf)**

5. INSTALL LOWER DEFROSTER NOZZLE ASSEMBLY

(a) Engage the 6 claws and remove the lower defroster nozzle assembly.

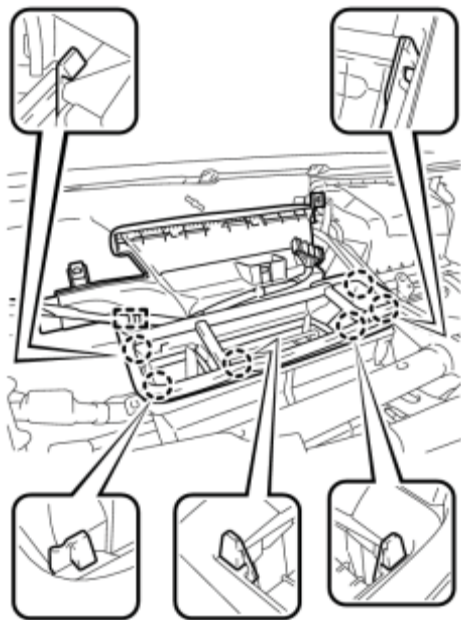

P

(b) Engage the clamp.

6. INSTALL DEFROSTER NOZZLE ASSEMBLY

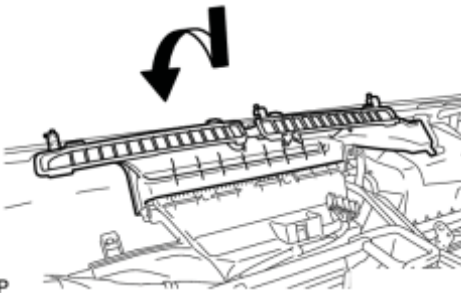

P

(a) Install the defroster nozzle assembly as shown in the illustration.

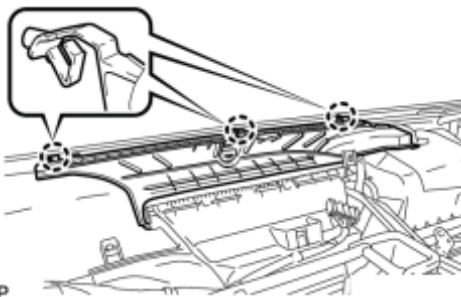

P

(b) Engage the 3 claws.

7. INSTALL NO. 2 INSTRUMENT PANEL BRACE SUB-ASSEMBLY

(a) Install the No. 2 instrument panel brace sub-assembly with the screw.

Torque: **4.0 N·m (41 kgf·cm, 35in·lbf)**

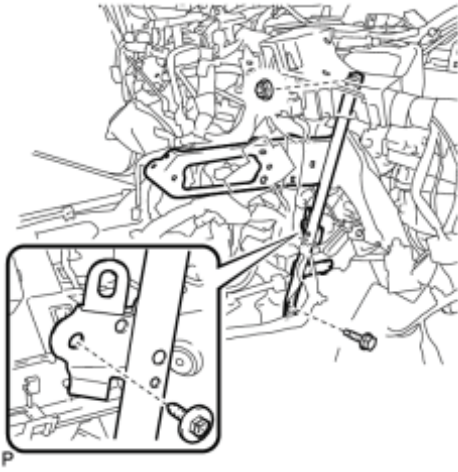

- (b) Install the bolt and nut.
- (c) Install the screw and 2 nuts to the computer integration box RH.
- (d) Engage each clamp.
- (e) Connect each connector.
- (f) Install the 3 screws <A>.
- (g) Install the bolt and connect the earth wire.

Torque: **8.4 N·m (86 kgf·cm, 74in·lbf)**

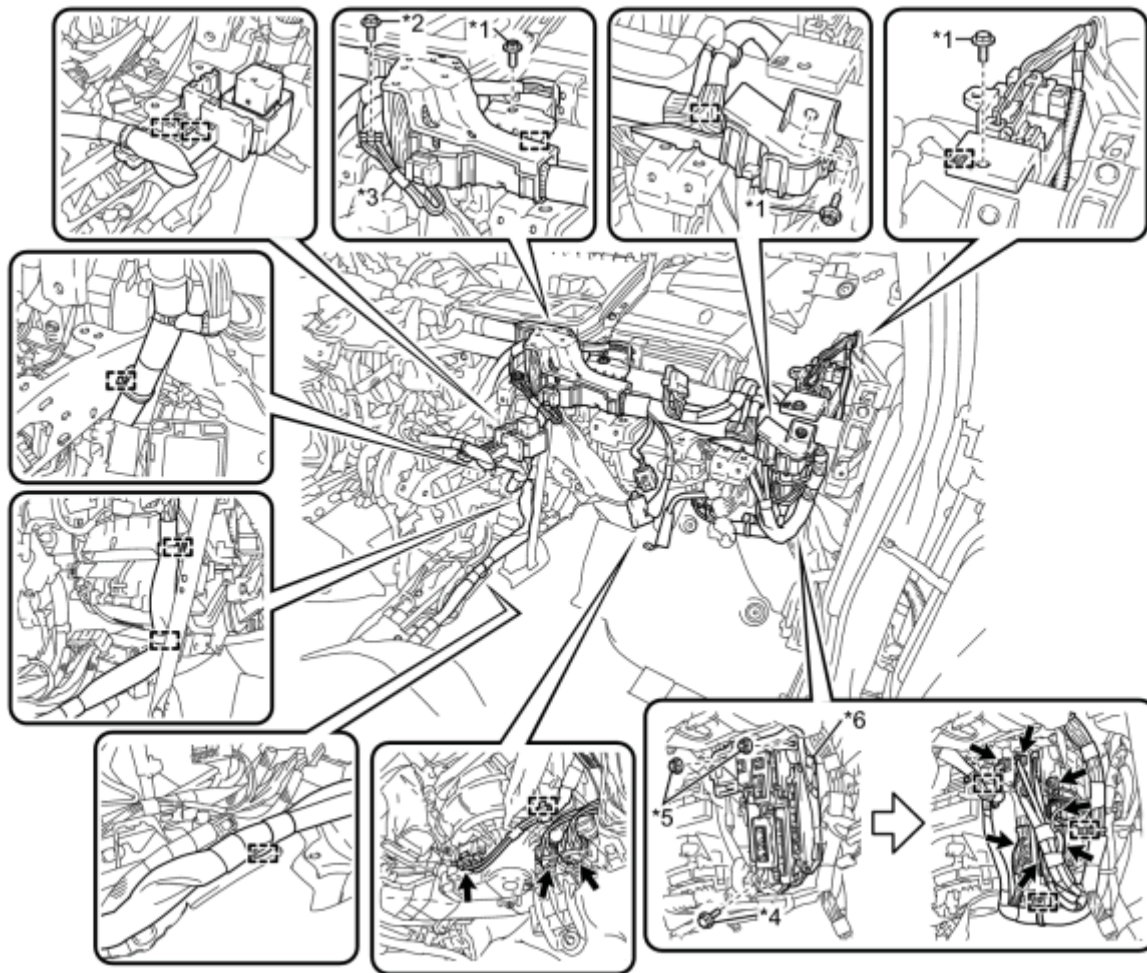

P

Text in Illustration

*1	Screw <A>	*2	Bolt
*3	Earth Wire	*4	Screw
*5	Nut	*6	Computer Integration Box RH

8. INSTALL NO. 1 INSTRUMENT PANEL BRACE SUB-ASSEMBLY

(a) Install the No. 1 instrument panel brace sub-assembly with the screw.

Torque: 4.0 N·m (41 kgf·cm, 35in·lbf)

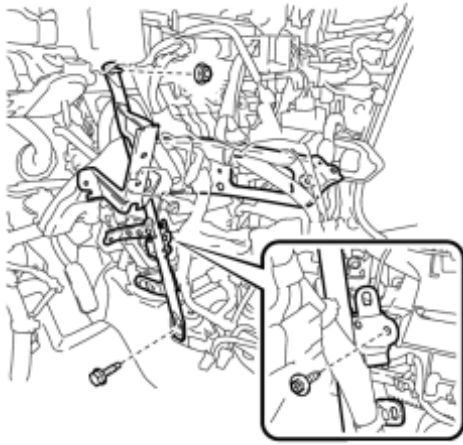

P

- (b) Install the bolt and nut.
- (c) Check that the power switch is off.
- (d) Check that the cable is disconnected from the negative (-) battery terminal.

CAUTION:

Wait at least 90 seconds after disconnecting the cable from the negative (-) battery terminal to disable the SRS system.

- (e) Connect the center airbag sensor connectors to the center airbag sensor assembly as shown in the illustration.

NOTICE:

When connecting any airbag connector, take care not to damage the airbag wire harness.

- (f) Check that the waterproof sheet on the top of the center airbag sensor is not folded or deformed.
- (g) Check that there is no looseness in the installation parts of the center airbag sensor assembly.
- (h) Connect each connector.
- (i) Engage each clamp and claw.
- (j) Install the screw.
- (k) Install the 2 bolts and connect the 2 earth wires.

Torque: **8.4 N·m (86 kgf·cm, 74in·lbf)**

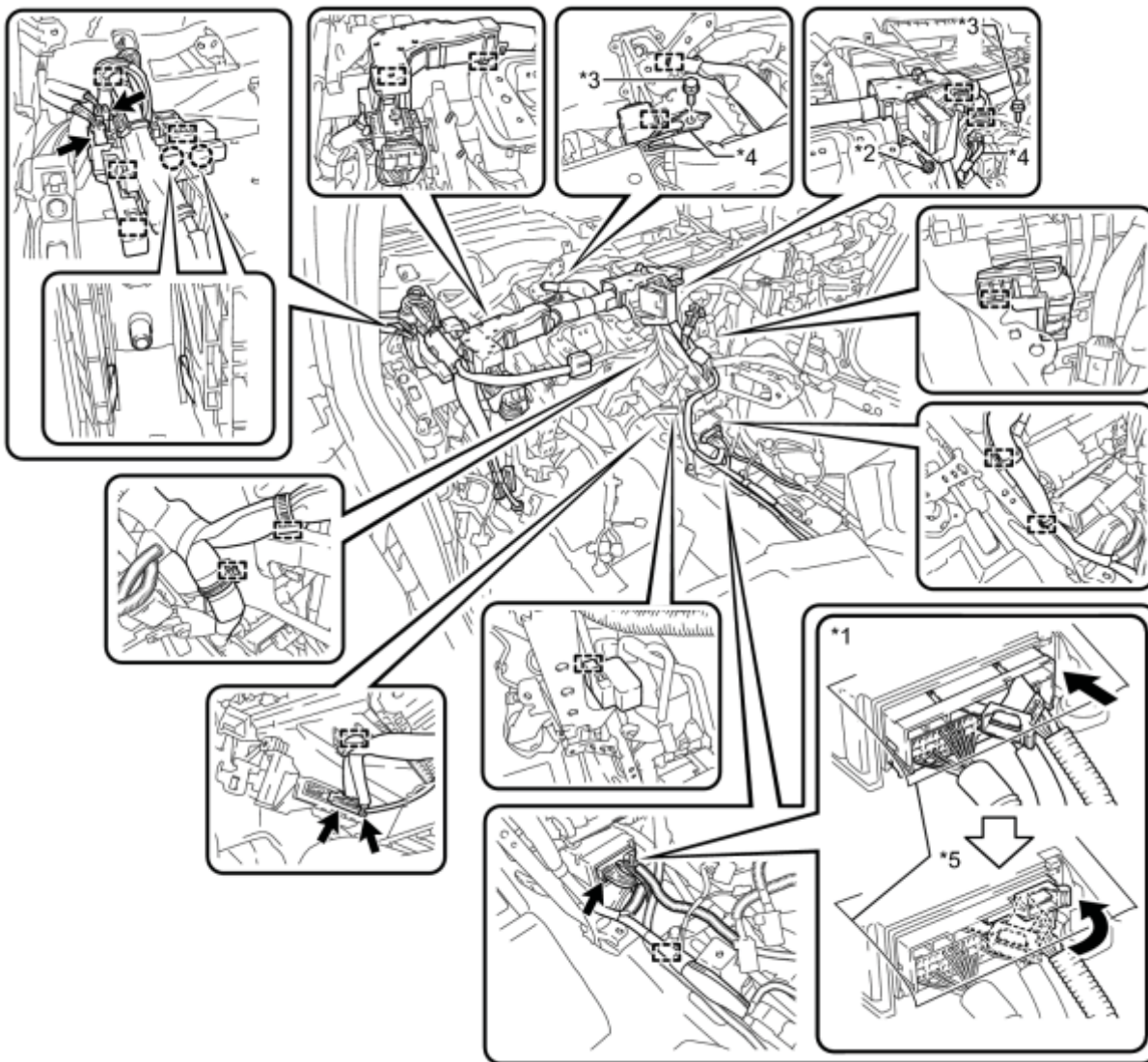

P

Text in Illustration

*1	Center Airbag Sensor Connector	*2	Screw
*3	Bolt	*4	Earth Wire
*5	Waterproof Sheet	-	-

9. INSTALL NO. 3 SIDE DEFROSTER NOZZLE DUCT

(a) Install the No. 3 side defroster nozzle duct with the clip.

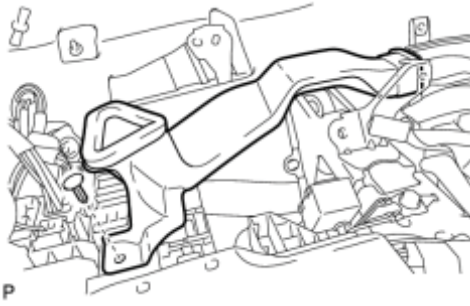

10. INSTALL REAR NO. 1 AIR DUCT (w/ Rear Air Duct)

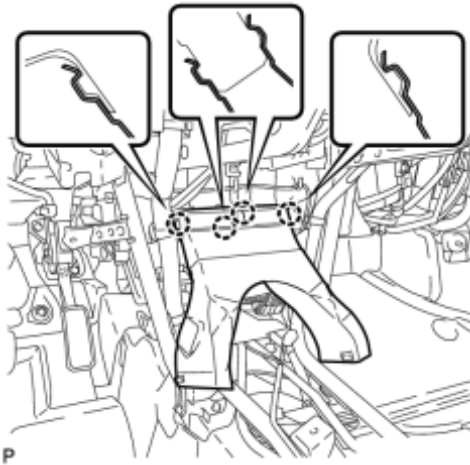

11. INSTALL REAR NO. 3 AIR DUCT (w/ Rear Air Duct)

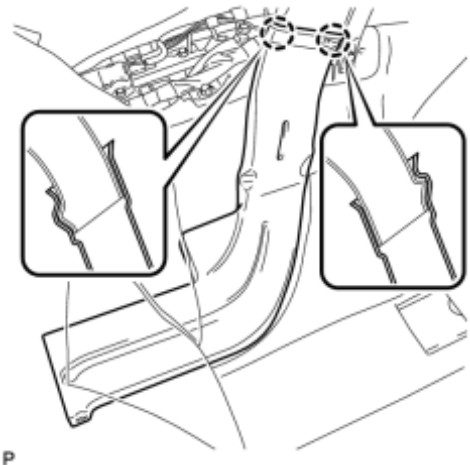

(b) Engage the 2 claws and install the clip.

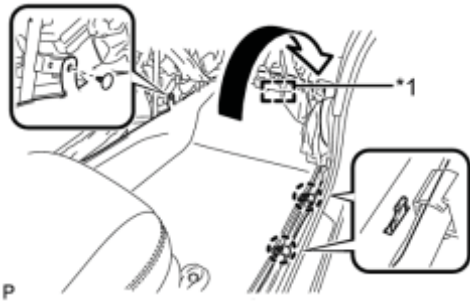

(c) Engage the fastener to install the floor carpet to the original position.

Text in Illustration

*1	Fastener
----	----------

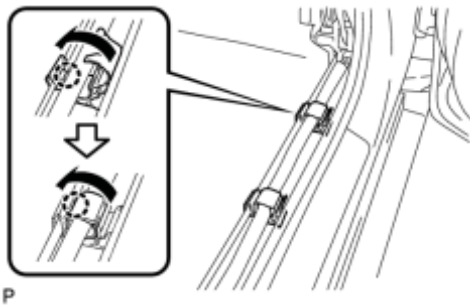

(d) Engage each claw to close the door scuff plate clamps as shown in the illustration.

12. INSTALL REAR NO. 2 AIR DUCT (w/ Rear Air Duct)

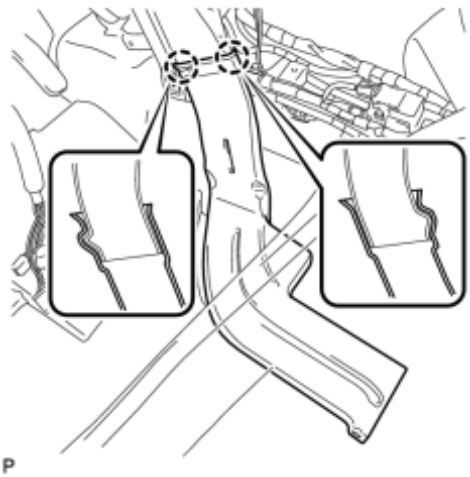

(a) Engage the 2 claws to install the rear No. 2 air duct.

(b) Engage the 2 claws and install the clip.

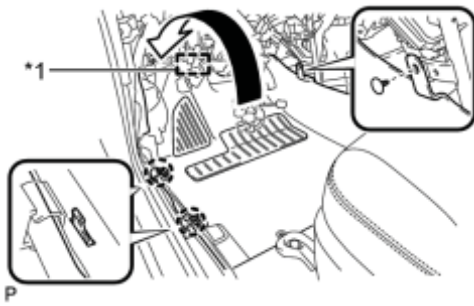

(c) Engage the fastener to install the floor carpet to the original position as shown in the illustration.

Text in Illustration

*1	Fastener
----	----------

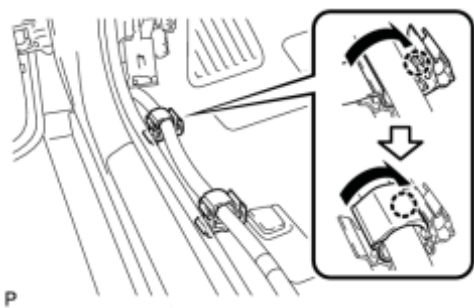

(d) Engage each claw to close the door scuff plate clamps as shown in the illustration.

13. INSTALL STEERING POST ASSEMBLY

for Brush Type Motor: [INFO](#)

for Brushless Type Motor: [INFO](#)

14. CONNECT NO. 2 STEERING INTERMEDIATE SHAFT ASSEMBLY_ [INFO](#)

15. INSTALL COLUMN HOLE COVER SILENCER SHEET_ [INFO](#)

16. INSTALL NO. 2 AIR DUCT SUB-ASSEMBLY_ [INFO](#)

17. INSTALL BRAKE PEDAL SUPPORT ASSEMBLY_ [INFO](#)

18. INSTALL PUSH ROD PIN_ [INFO](#)

19. INSTALL BRAKE PEDAL RETURN SPRING_ [INFO](#)

20. INSTALL STOP LIGHT SWITCH MOUNTING ADJUSTER

21. INSTALL STOP LIGHT SWITCH ASSEMBLY_ [INFO](#)

22. INSTALL DRIVER SIDE JUNCTION BLOCK ASSEMBLY_ [INFO](#)

23. INSTALL LOWER INSTRUMENT PANEL SUB-ASSEMBLY_ [INFO](#)
24. INSTALL NO. 2 ANTENNA CORD SUB-ASSEMBLY_ [INFO](#)
25. INSTALL INSTRUMENT PANEL SAFETY PAD PLATE SUB-ASSEMBLY (for LHD)_ [INFO](#)
26. INSTALL POWER STEERING ECU ASSEMBLY (for Brush Type Motor)_ [INFO](#)
27. INSTALL POWER STEERING ECU ASSEMBLY (for Brushless Type Motor)_ [INFO](#)
28. INSTALL COMBINATION METER ASSEMBLY_ [INFO](#)
29. INSTALL NO. 1 HEATER TO REGISTER DUCT_ [INFO](#)
30. INSTALL COWL SIDE TRIM BOARD RH

HINT:

Use the same procedure for the RH side and LH side.

31. INSTALL FRONT DOOR SCUFF PLATE RH

HINT:

Use the same procedure for the RH side and LH side.

32. INSTALL GLOVE COMPARTMENT DOOR ASSEMBLY_ [INFO](#)
33. INSTALL NO. 2 INSTRUMENT PANEL UNDER COVER SUB-ASSEMBLY_ [INFO](#)
34. INSTALL DRIVER SIDE KNEE AIRBAG ASSEMBLY_ [INFO](#)
35. INSTALL NO. 1 INSTRUMENT PANEL UNDER COVER SUB-ASSEMBLY_ [INFO](#)
36. ALIGN FRONT WHEELS FACING STRAIGHT AHEAD
37. INSTALL TURN SIGNAL SWITCH ASSEMBLY WITH SPIRAL CABLE SUB-ASSEMBLY_ [INFO](#)
38. INSTALL UPPER STEERING COLUMN COVER_ [INFO](#)
39. INSTALL LOWER STEERING COLUMN COVER_ [INFO](#)
40. INSTALL STEERING WHEEL ASSEMBLY_ [INFO](#)
41. INSTALL STEERING PAD_ [INFO](#)
42. INSTALL LOWER NO. 3 STEERING WHEEL COVER_ [INFO](#)
43. INSTALL LOWER NO. 2 STEERING WHEEL COVER_ [INFO](#)

44. INSTALL NO. 1 SWITCH HOLE BASE_ [INFO](#)
45. INSTALL UPPER INSTRUMENT PANEL FINISH PANEL ASSEMBLY_ [INFO](#)
46. INSTALL SHIFT LOCK CONTROL UNIT ASSEMBLY_ [INFO](#)
47. INSTALL AIR CONDITIONING CONTROL ASSEMBLY_ [INFO](#)
48. INSTALL CONSOLE BOX ASSEMBLY_ [INFO](#)
49. INSTALL BOX BOTTOM MAT_ [INFO](#)
50. INSTALL FRONT NO. 2 CONSOLE BOX INSERT_ [INFO](#)
51. INSTALL FRONT NO. 1 CONSOLE BOX INSERT_ [INFO](#)
52. INSTALL NO. 2 CONSOLE BOX MOUNTING BRACKET_ [INFO](#)
53. INSTALL ELECTRICAL KEY OSCILLATOR_ [INFO](#)
54. INSTALL REAR CONSOLE BOX ASSEMBLY (w/ Power Outlet Socket)_ [INFO](#)
55. INSTALL REAR CONSOLE BOX ASSEMBLY (w/o Power Outlet Socket)_ [INFO](#)
56. INSTALL CONSOLE BOX CARPET_ [INFO](#)
57. INSTALL UPPER CONSOLE PANEL (w/ Power Outlet Socket)_ [INFO](#)
58. INSTALL REAR CONSOLE BOX POCKET (w/ Power Outlet Socket)_ [INFO](#)
59. INSTALL UPPER INSTRUMENT PANEL ASSEMBLY_ [INFO](#)
60. CONNECT INSTRUMENT PANEL WIRE_ [INFO](#)
61. INSTALL CENTER INSTRUMENT CLUSTER FINISH PANEL GARNISH_ [INFO](#)
62. INSTALL FRONT NO. 2 SPEAKER ASSEMBLY

HINT:

Use the same procedure for the RH side and LH side.

63. INSTALL NO. 2 INSTRUMENT PANEL SPEAKER PANEL SUB-ASSEMBLY_ [INFO](#)
64. INSTALL FRONT PILLAR GARNISH CORNER PIECE RH_ [INFO](#)
65. INSTALL FRONT PILLAR GARNISH RH

HINT:

Use the same procedure for the RH side and LH side.

66. INSTALL FRONT NO. 2 SPEAKER ASSEMBLY_ [INFO](#)
67. INSTALL NO. 1 INSTRUMENT PANEL SPEAKER PANEL SUB-ASSEMBLY_ [INFO](#)
68. INSTALL FRONT PILLAR GARNISH CORNER PIECE LH_ [INFO](#)
69. INSTALL FRONT PILLAR GARNISH LH_ [INFO](#)
70. INSTALL INSTRUMENT PANEL FINISH PANEL END RH_ [INFO](#)
71. CONNECT FRONT DOOR OPENING TRIM WEATHERSTRIP RH_ [INFO](#)
72. INSTALL GLOVE COMPARTMENT DOOR_ [INFO](#)
73. INSTALL NO. 2 INSTRUMENT PANEL REGISTER_ [INFO](#)
74. INSTALL NO. 1 SIDE DEFROSTER NOZZLE_ [INFO](#)
75. INSTALL INSTRUMENT PANEL FINISH PANEL END LH_ [INFO](#)
76. CONNECT FRONT DOOR OPENING TRIM WEATHERSTRIP LH_ [INFO](#)
77. INSTALL NO. 1 CENTER INSTRUMENT CLUSTER FINISH PANEL_ [INFO](#)
78. INSTALL NO. 1 INSTRUMENT PANEL REGISTER_ [INFO](#)
79. INSTALL LOWER INSTRUMENT PANEL FINISH PANEL ASSEMBLY_ [INFO](#)
80. INSTALL COWL SIDE TRIM SUB-ASSEMBLY LH_ [INFO](#)
81. INSTALL FRONT DOOR SCUFF PLATE LH_ [INFO](#)
82. INSTALL NAVIGATION RECEIVER WITH BRACKET (w/ Navigation System)_ [INFO](#)
83. INSTALL RADIO RECEIVER WITH BRACKET (w/o Navigation System)_ [INFO](#)
84. INSTALL UPPER INSTRUMENT PANEL FINISH PANEL SUB-ASSEMBLY_ [INFO](#)
85. INSTALL INSTRUMENT CLUSTER FINISH PANEL GARNISH_ [INFO](#)
86. INSTALL LOWER CENTER INSTRUMENT CLUSTER FINISH PANEL SUB-ASSEMBLY_ [INFO](#)
87. INSTALL INTEGRATION CONTROL AND PANEL ASSEMBLY_ [INFO](#)
88. CONNECT OUTLET HEATER WATER HOSE

(a) Using pliers, grip the claws of the clip and slide the clip to connect the

outlet heater water hose.

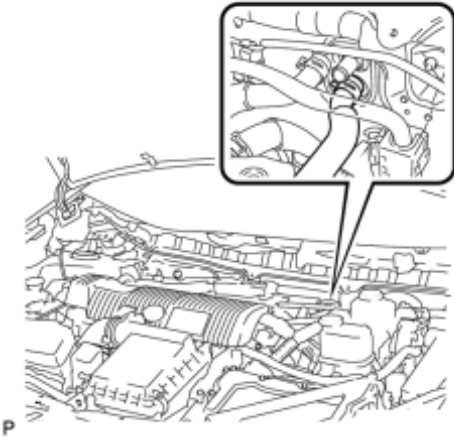

89. CONNECT INLET HEATER WATER HOSE

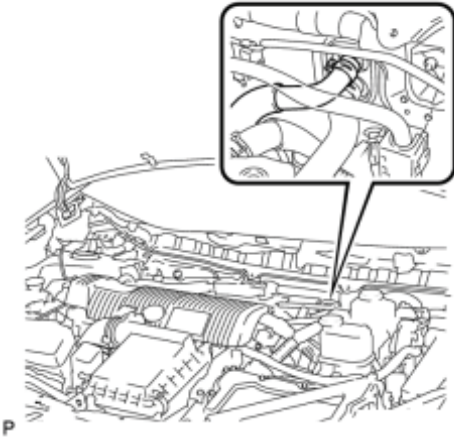

(a) Using pliers, grip the claws of the clip and slide the clip to connect the inlet heater water hose.

90. CONNECT AIR CONDITIONING TUBE AND ACCESSORY ASSEMBLY

(a) Remove the attached vinyl tape from the pipe.

(b) Sufficiently apply compressor oil to a new O-ring and the fitting surface of the air conditioning tube and accessory assembly.

Compressor oil:

ND-OIL 11 or equivalent

(c) Install the O-ring on the air conditioning tube and accessory assembly.

NOTICE:

- Keep the O-ring and O-ring fitting surfaces clean from dirt or any foreign objects.

- Do not use any compressor oil other than ND-OIL 11 or equivalent. If any compressor oil other than ND-OIL 11 or equivalent is used, compressor motor insulation performance may decrease, resulting in a leakage of electric power.

(d) Install the air conditioning tube and accessory assembly.

91. CONNECT SUCTION PIPE SUB-ASSEMBLY

(a) Remove the attached vinyl tape from the pipe.

(b) Sufficiently apply compressor oil to a new O-ring and the fitting surface of the suction pipe sub-assembly.

Compressor oil:

ND-OIL 11 or equivalent

(c) Install the O-ring on the suction pipe sub-assembly.

NOTICE:

- Keep the O-ring and O-ring fitting surfaces clean from dirt or any foreign objects.
- Do not use any compressor oil other than ND-OIL 11 or equivalent. If any compressor oil other than ND-OIL 11 or equivalent is used, compressor motor insulation performance may decrease, resulting in a leakage of electric power.

(d) Install the suction pipe sub-assembly.

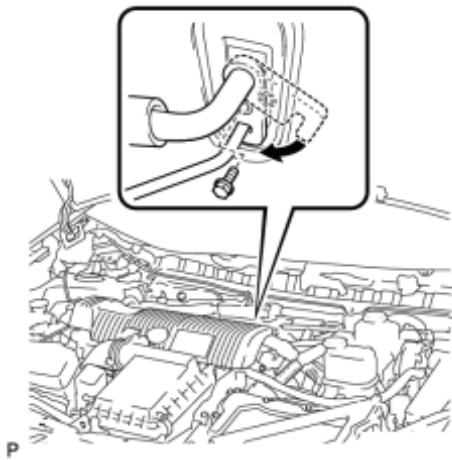

(e) Move the hook connector in the direction indicated by the arrow in the illustration.

(f) Insert the pipe joint into the fitting hole securely and tighten the bolt.

Torque: **9.8 N·m (100 kgf·cm, 87in·lbf)**

92. INSTALL OUTER COWL TOP PANEL SUB-ASSEMBLY_ INFO

93. INSTALL COWL BODY MOUNTING REINFORCEMENT LH_ INFO

94. INSTALL WINDSHIELD WIPER MOTOR AND LINK ASSEMBLY_ INFO

95. INSTALL COWL TOP VENTILATOR LOUVER SUB-ASSEMBLY_ INFO

96. INSTALL COWL SIDE VENTILATOR SUB-ASSEMBLY LH_ INFO

97. INSTALL COWL SIDE VENTILATOR SUB-ASSEMBLY RH_ INFO

98. INSTALL FRONT WIPER ARM AND BLADE ASSEMBLY RH_ INFO

99. INSTALL FRONT WIPER ARM AND BLADE ASSEMBLY LH_ INFO

100. INSTALL FRONT WIPER ARM HEAD CAP_ INFO

101. CONNECT CABLE TO NEGATIVE BATTERY TERMINAL

NOTICE:

When disconnecting the cable, some systems need to be initialized after the cable is reconnected INFO.

102. INSTALL REAR NO. 3 FLOOR BOARD_ INFO

103. INSTALL REAR DECK FLOOR BOX_ INFO

104. INSTALL REAR NO. 2 FLOOR BOARD (for Separate Type)_ INFO

105. ADD COOLANT (for Engine)_ INFO

106. CHARGE WITH REFRIGERANT_ INFO

107. WARM UP COMPRESSOR_ INFO

108. INSPECT FOR REFRIGERANT LEAK_ INFO

109. INSPECT FOR COOLANT LEAK (for Engine)_ INFO

110. INSPECT SHIFT LEVER_ INFO

111. INSPECT STEERING PAD

(a) Inspect the steering pad INFO.

112. INSPECT SRS WARNING LIGHT

(a) Inspect the SRS warning light INFO.