

**N\*m (kgf\*cm, ft.\*lbf)** : Specified torque

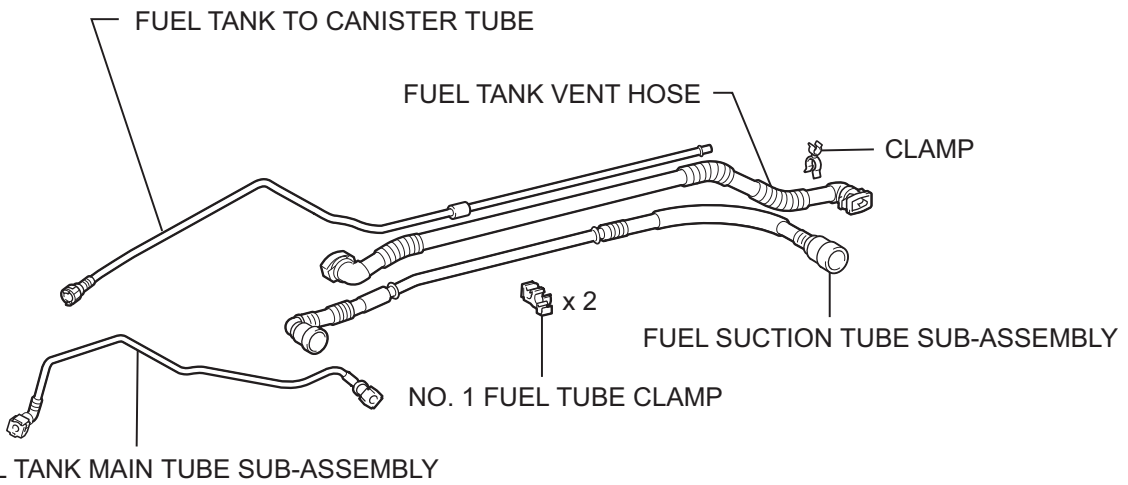

FU

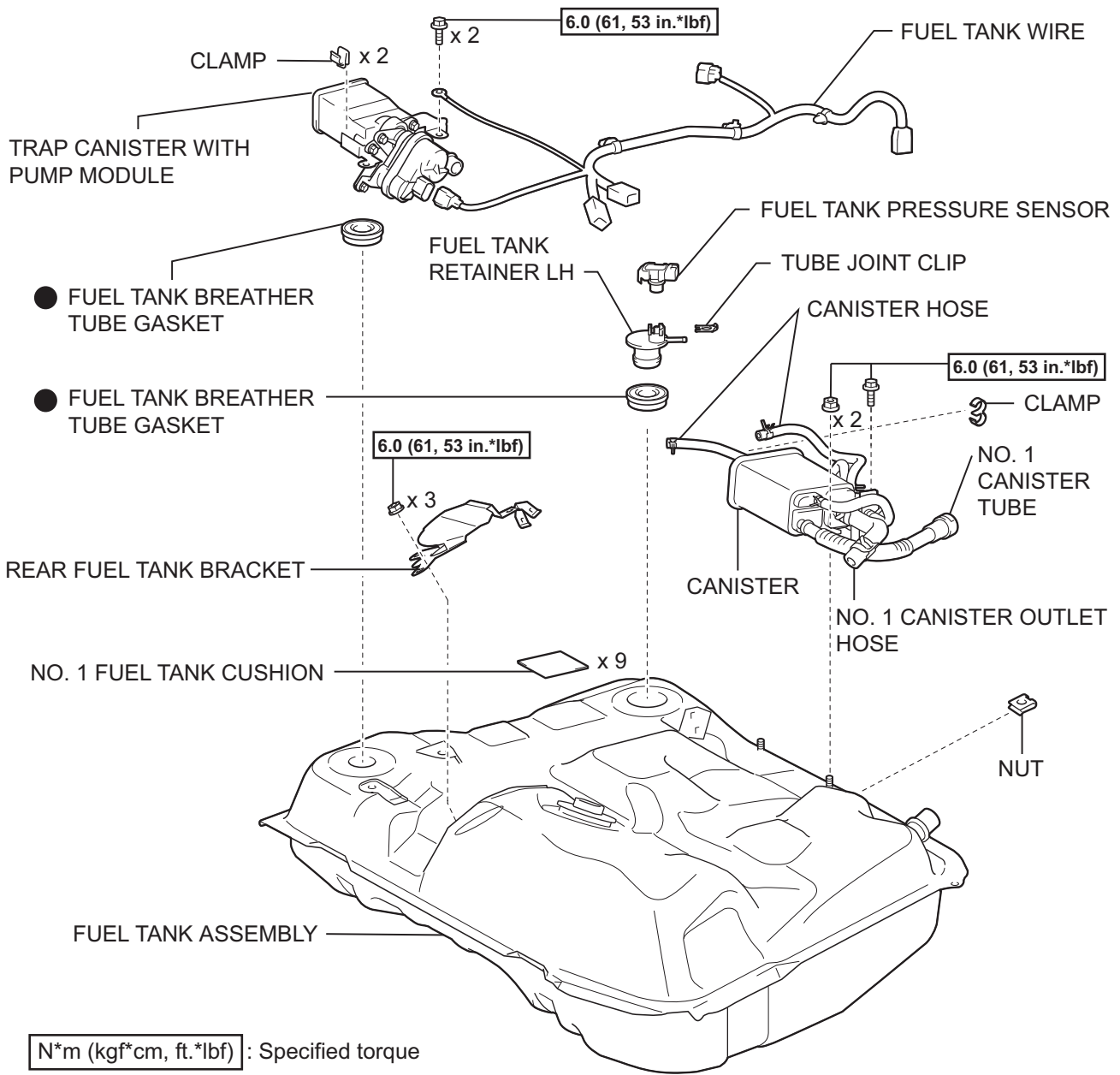

N\*m (kgf\*cm, ft.\*lbf) : Specified torque

● Non-reusable part

## REMOVAL

1. **DISCHARGE FUEL SYSTEM PRESSURE** (See page [FU-12](#))
2. **REMOVE INSTRUMENT PANEL FINISH PANEL LOWER CENTER** (See page [IP-18](#))
3. **REMOVE FRONT FLOOR PANEL BRACE** (See page [EX-2](#))
4. **REMOVE FRONT EXHAUST PIPE ASSEMBLY** (See page [EX-2](#))
5. **REMOVE REAR SEAT CUSHION ASSEMBLY** (See page [SE-15](#))
6. **REMOVE REAR FLOOR SERVICE HOLE COVER**
  - (a) Remove the butyl tape and rear floor service hole cover.
  - (b) Disconnect the fuel pump connector.
  - (c) Disconnect the wire to wire connector.

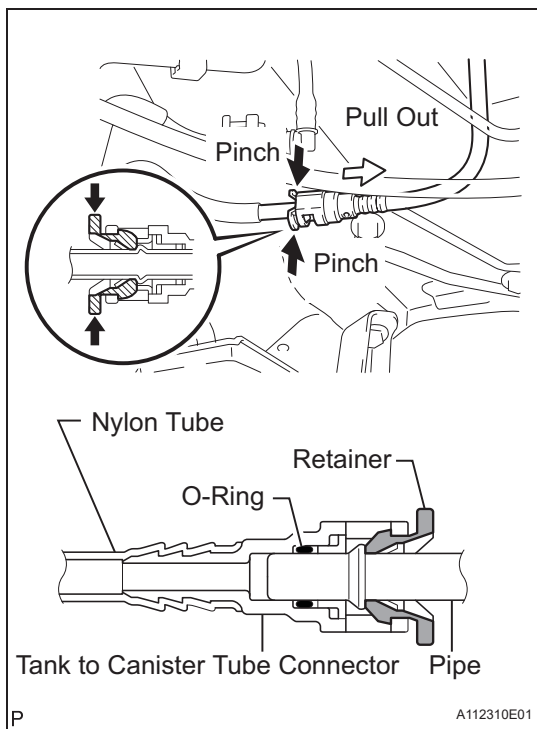
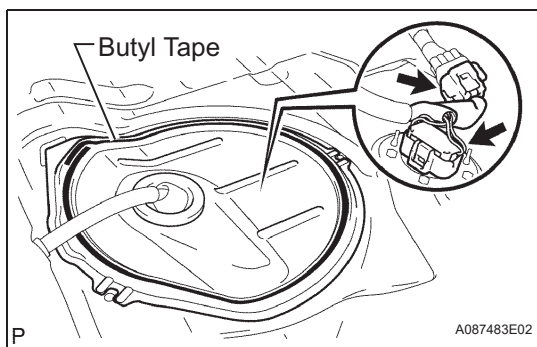

## 7. REMOVE FUEL TANK ASSEMBLY

- (a) Disconnect the fuel tank to canister tube.
  - (1) Pinch the retainer of the fuel tube connector, then pull out the fuel tube connector to disconnect the fuel tank to canister tube from the pipe.

### NOTICE:

- Remove dirt or foreign objects on the fuel tube connector before this procedure.
- Do not allow any scratches or foreign objects on the parts when disconnecting them as the fuel tube connector has the O-ring that seals the pipe.
- Perform this work by hand. Do not use any tools.
- Do not forcibly bend, twist or turn the nylon tube.
- Protect the connecting part by covering it with a plastic bag after disconnecting the fuel tank to canister tube.
- If the fuel tube connector and pipe are stuck, push and pull them to release them.

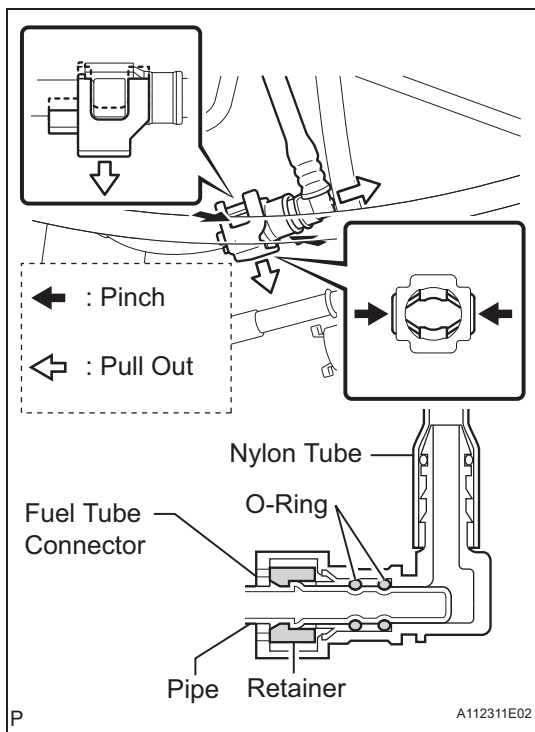

- (b) Disconnect the No. 2 fuel tank main tube.
- (1) Remove the checker of the fuel tube connector from the pipe.
  - (2) Pinch the retainer of the fuel tube connector, and then pull out the fuel tube connector to disconnect the No. 2 fuel tank main tube from the pipe.

**NOTICE:**

- Remove dirt or foreign objects on the fuel tube connector before this procedure.
- Do not allow any scratches or foreign objects on the parts when disconnecting them as the fuel tube connector has the O-ring that seals the pipe.
- Perform this work by hand. Do not use any tools.
- Do not forcibly bend, twist or turn the nylon tube.
- Protect the connecting part by covering it with a plastic bag after disconnecting the No. 2 fuel tank main tube.
- If the fuel tube connector and pipe are stuck, push and pull them to release them.

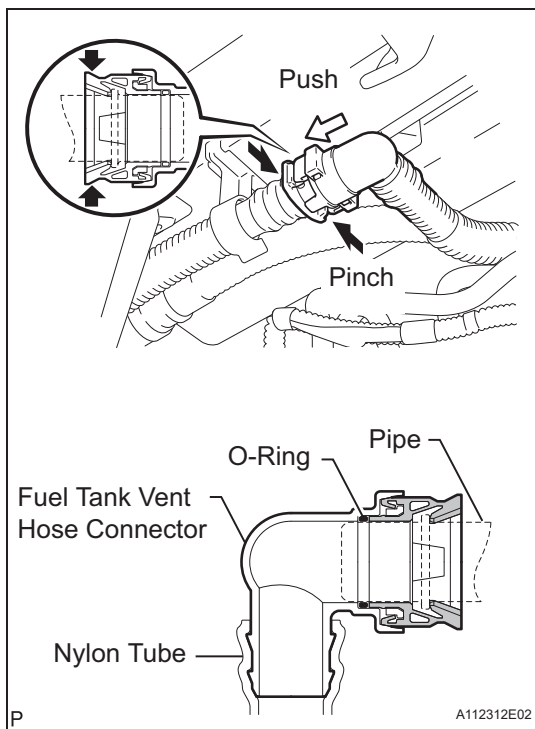

- (c) Disconnect the fuel tank vent hose.
- (1) Pinch the retainer and pull out the fuel tank vent hose connector with the fuel tank vent hose connector pushed to the pipe side to disconnect the fuel tank vent hose from the canister filter.

**NOTICE:**

- Remove dirt or foreign objects on the fuel tank vent hose connector before this procedure.
- Do not allow any scratches or foreign objects on the parts when disconnecting them as the fuel tank vent hose connector has the O-ring that seals the pipe.
- Perform this work by hand. Do not use any tools.
- Do not forcibly bend, twist or turn the nylon tube.
- Protect the connecting part by covering it with a plastic bag after disconnecting the fuel tank vent hose.
- If the fuel tank vent hose connector and pipe are stuck, push and pull them to release them.

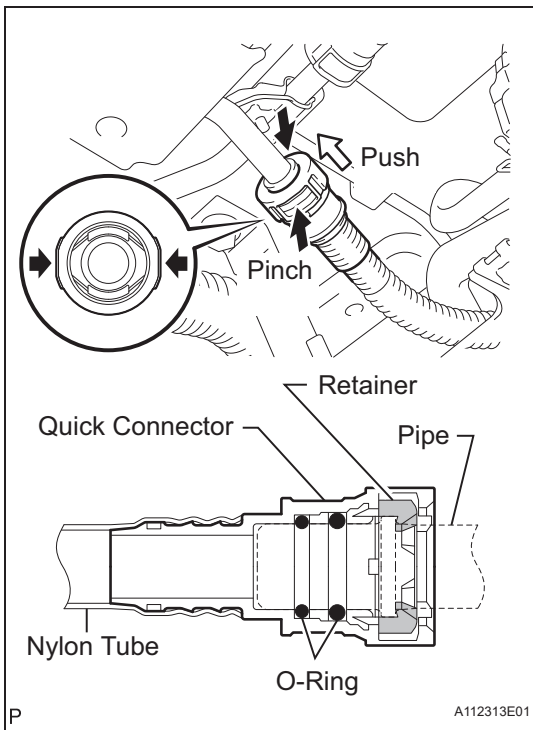

- (d) Disconnect the fuel suction tube.
- (1) Pinch the retainer and pull out the suction tube connector with the suction tube connector pushed to the pipe side to disconnect the fuel suction tube from the fuel tank to filler pipe.

**NOTICE:**

- Remove dirt or foreign objects on the quick connector before this procedure.
- Do not allow any scratches or foreign objects on the parts when disconnecting them as the fuel suction tube connector has the O-ring that seals the pipe.
- Perform this work by hand. Do not use any tools.
- Do not forcibly bend, twist or turn the nylon tube.
- Protect the connecting part by covering it with a plastic bag after disconnecting the fuel suction tube.
- If the fuel suction tube connector and pipe are stuck, push and pull them to release them.

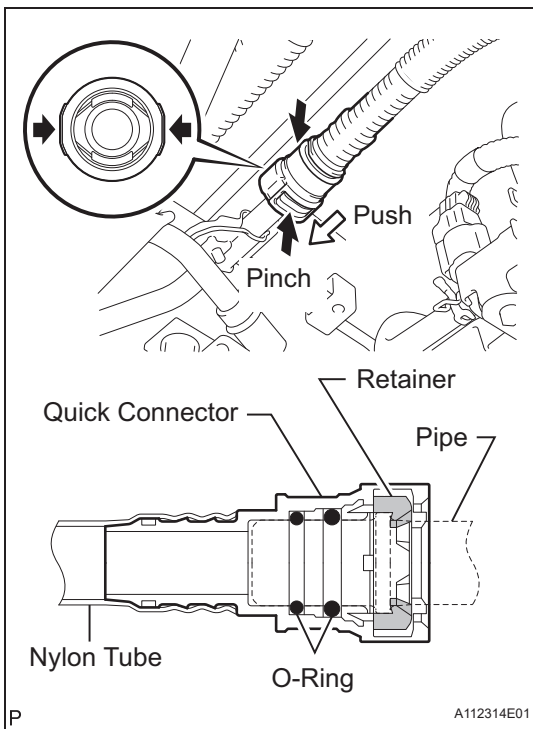

- (e) Disconnect the No. 1 canister tube.
- (1) Pinch the retainer and pull out the No. 1 canister tube connector with the No. 1 canister tube connector pushed to the pipe side to disconnect the No. 1 canister tube from the fuel tank to filler pipe.

**NOTICE:**

- Remove dirt or foreign objects on the quick connector before this procedure.
- Do not allow any scratches or foreign objects on the parts when disconnecting them as the No. 1 canister tube connector has the O-ring that seals the pipe.
- Perform this work by hand. Do not use any tools.
- Do not forcibly bend, twist or turn the nylon tube.
- Protect the connecting part by covering it with a plastic bag after disconnecting the tank to canister tube.
- If the No. 1 canister tube connector and pipe are stuck, push and pull them to release them.

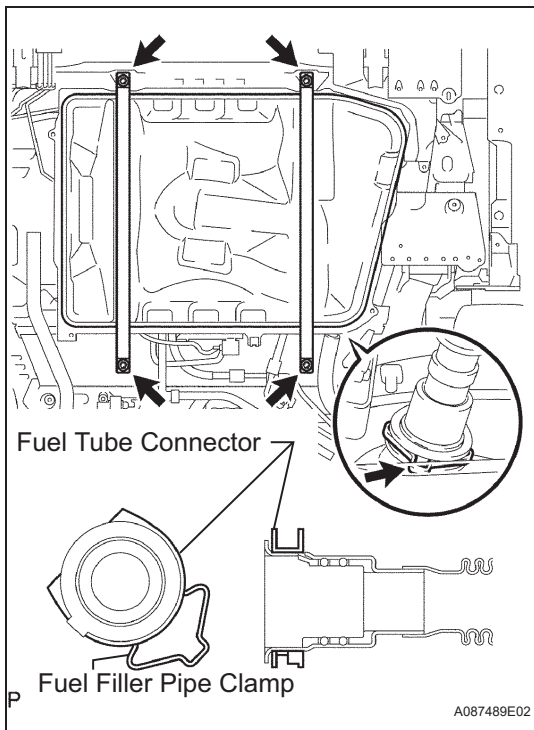

- (f) Set a transmission jack to the fuel tank.
- (g) Remove the fuel filler pipe clamp and fuel tube connector from the fuel tank inlet pipe.
- (h) Remove the 4 bolts and No. 1 fuel tank band RH and LH.
- (i) Operate the transmission jack, and then disconnect the fuel tank inlet pipe.
- (j) Operate the transmission jack, and then remove the fuel tank.

FU

#### 8. REMOVE NO. 2 FUEL TANK MAIN TUBE SUB-ASSEMBLY

- (a) Remove the 3 nuts and rear fuel tank bracket.
- (b) Disconnect the wire to wire connector from the rear fuel tank bracket.

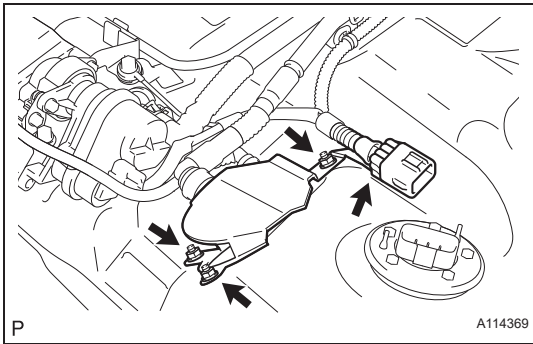

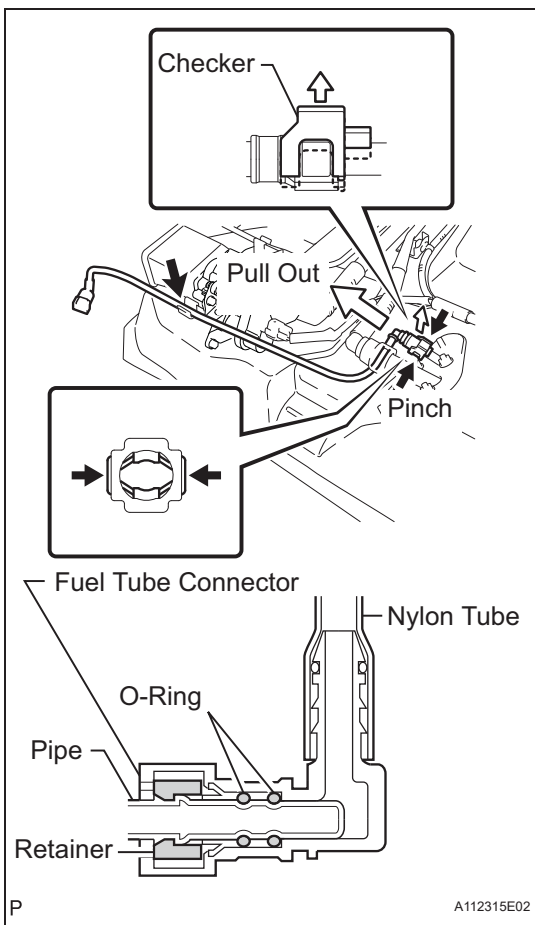

- (c) Disconnect the No. 2 fuel tank main tube from the clamp.
- (d) Remove the checker of the main tube connector from the pipe.
- (e) Pinch the retainer of the main tube connector, then pull out the fuel tube connector to disconnect the No. 2 fuel tank main tube from the pipe.

**NOTICE:**

- Remove dirt or foreign objects on the fuel tube connector before this procedure.
- Do not allow any scratches or foreign objects on the parts when disconnecting them as the fuel tube connector has the O-ring that seals the pipe.
- Perform this work by hand. Do not use any tools.
- Do not forcibly bend, twist or turn the nylon tube.
- Protect the connecting part by covering it with a plastic bag after disconnecting the No. 2 fuel tank main tube.
- If the fuel tube connector and pipe are stuck, push and pull them to release them.

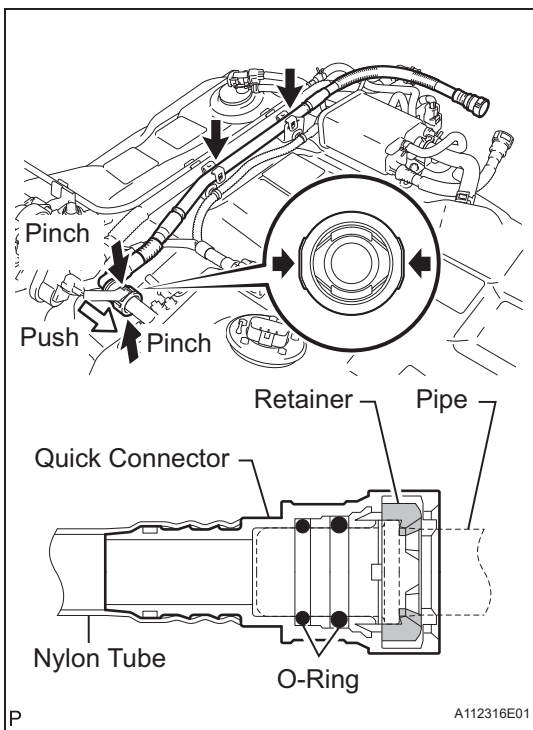
**9. REMOVE FUEL SUCTION TUBE SUB-ASSEMBLY**

- (a) Disconnect the fuel suction tube from the 2 No. 1 fuel tube clamps.
- (b) Pinch the retainer and pull out the suction tube connector with the quick connector pushed to the pipe side to disconnect the fuel suction tube from the pipe.

**NOTICE:**

- Remove dirt or foreign objects on the quick connector before this procedure.
- Do not allow any scratches or foreign objects on the parts when disconnecting them as the suction tube connector has the O-ring that seals the pipe.
- Perform this work by hand. Do not use any tools.
- Do not forcibly bend, twist or turn the nylon tube.
- Protect the connecting part by covering it with a plastic bag after disconnecting the fuel suction tube.
- If the quick connector and pipe are stuck, push and pull them to release them.

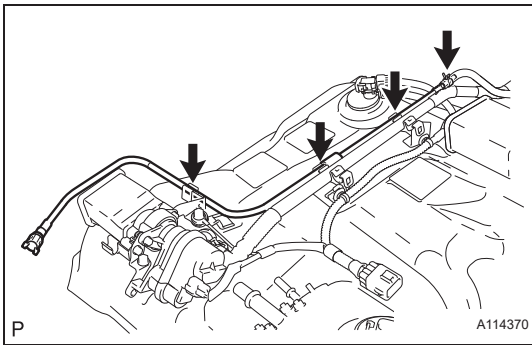

### 10. REMOVE FUEL TANK TO CANISTER TUBE

- Disconnect the fuel tank to canister tube from the clamp.
- Disconnect the fuel tank to canister tube from the 2 No. 1 fuel tube clamps.
- Remove the fuel tank to canister tube from the fuel tank.

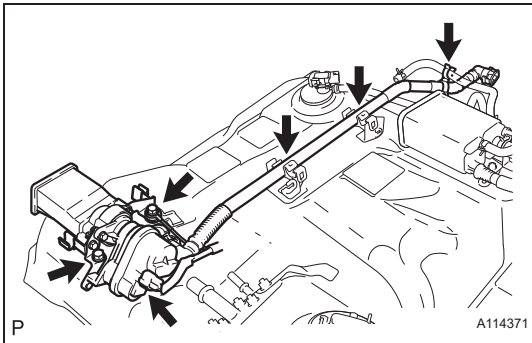

### 11. REMOVE TRAP CANISTER WITH PUMP MODULE

- Disconnect the VSV connector.
- Remove the clamp from the fuel tank vent hose and canister hose.
- Remove the fuel tank vent hose from the 2 fuel tube clamps.
- Remove the 2 bolts and trap canister with pump module and disconnect the ground terminal of the fuel tank wire.

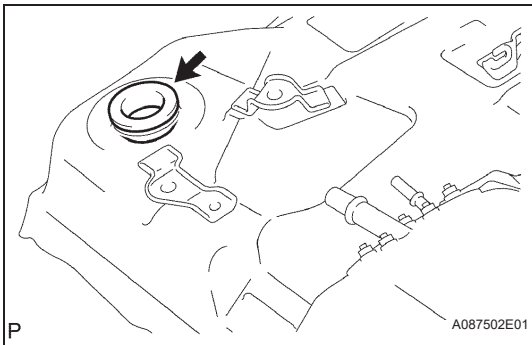

- Remove the gasket from the fuel tank.

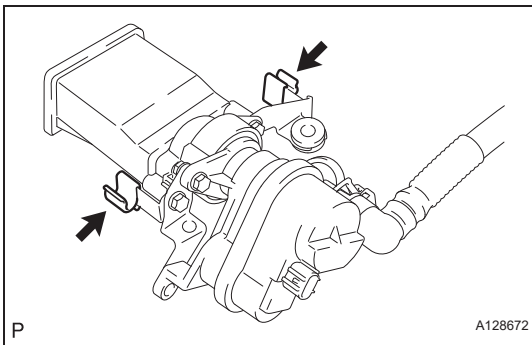

- Remove the 2 clamps from the trap canister with pump module.



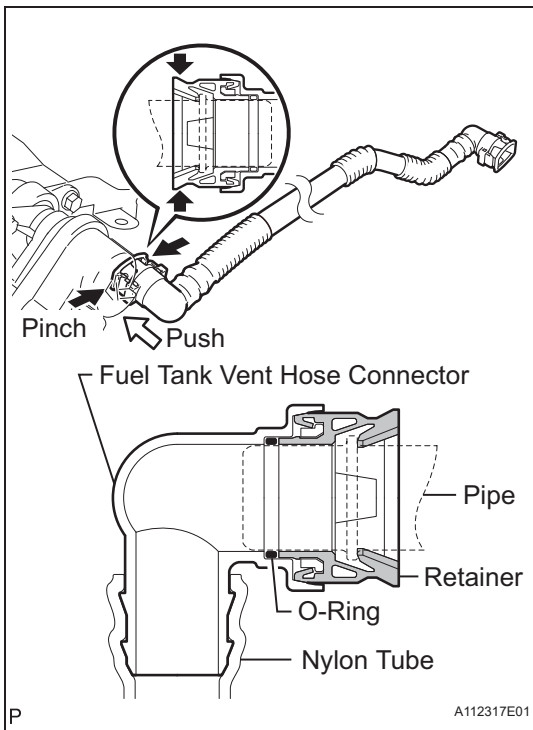

## 12. REMOVE FUEL TANK VENT HOSE

- (a) Pinch the retainer and pull out the fuel tank vent hose connector with the fuel tank vent hose connector pushed to the fuel tank vent hose side to disconnect the fuel tank vent hose from the trap with outlet valve canister.

### NOTICE:

- Remove dirt of foreign objects on the fuel tank vent hose connector before this procedure.
- Do not allow any scratches or foreign objects on the parts when disconnecting them as the fuel tank vent hose connector has the O-ring that seals the pipe.
- Perform this work by hand. Do not use any tools.
- Do not forcibly bend, twist or turn the nylon tube.
- Protect the connecting part by covering it with a plastic bag after disconnecting the fuel tank vent hose.
- If the fuel tank vent hose connector and pipe are stuck, push and pull them to release them.

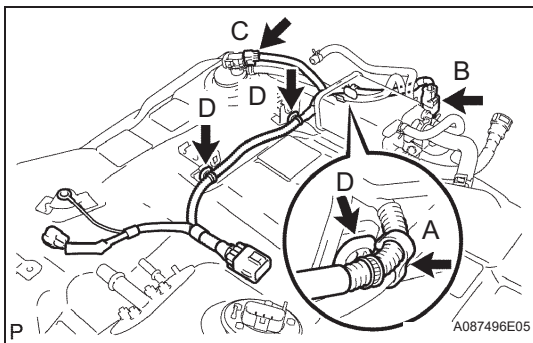

## 13. REMOVE FUEL TANK WIRE

- (a) Remove the clamp as shown in the illustration A.
- (b) Disconnect the VSV connector as shown in the illustration B.
- (c) Disconnect the vapor pressure sensor connector as shown in the illustration C.
- (d) Remove the 3 wire harness clamps as shown in the illustration D.

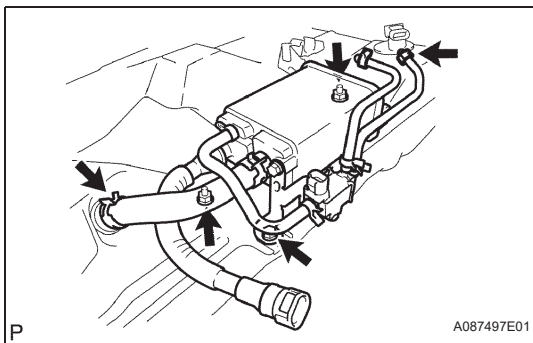

## 14. REMOVE CANISTER

- (a) Disconnect the canister hose from the fuel tank retainer.
- (b) Disconnect the No. 1 canister outlet hose from the fuel tank.
- (c) Remove the bolt, 2 nuts and canister.

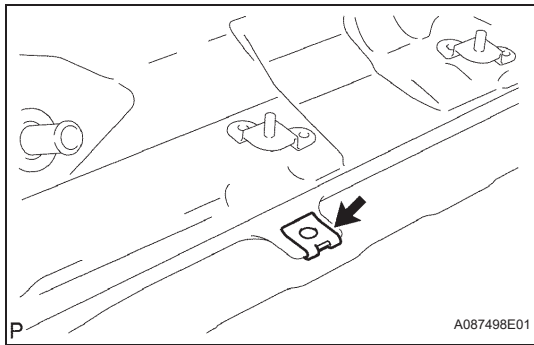

(d) Remove the nut from the fuel tank.

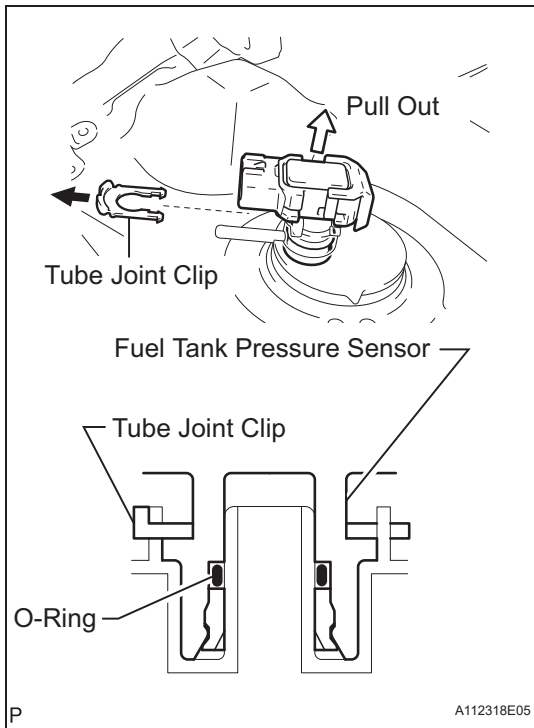

## 15. REMOVE FUEL TANK PRESSURE SENSOR

(a) Remove the tube joint clip, then pull out the fuel tank pressure sensor from the fuel tank retainer LH.

### NOTICE:

- Remove dirt or foreign objects on fuel tank pressure sensor before this procedure.
- Do not allow any scratches or foreign objects on the parts when disconnecting them as the fuel tank pressure sensor has the O-ring that seals the plug.
- Perform this work by hand. Do not use any tools.

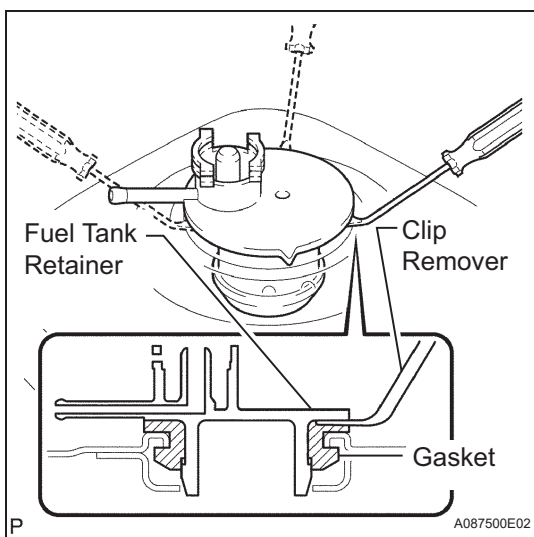

## 16. REMOVE FUEL TANK RETAINER LH

(a) Insert a clip remover between the fuel tank retainer and gasket, then remove the fuel tank retainer by lifting it little by little.

### NOTICE:

- The fuel tank retainer is made of resin and easily damaged if removed or installed forcibly. Handle the part correctly to ensure proper sealing.
- After removing the fuel tank retainer, check that the contact surface of the fuel tank retainer on the fuel tank is not damaged.

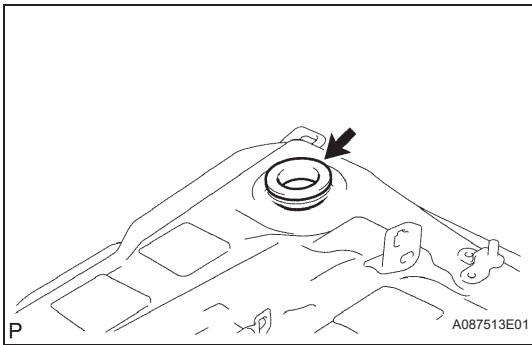

(b) Remove the gasket from the fuel tank.

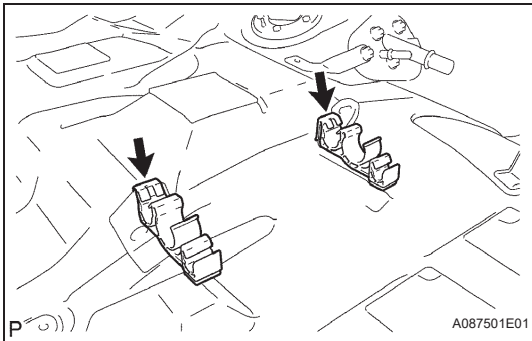

### 17. REMOVE NO. 1 FUEL TUBE CLAMP

(a) Remove the 2 clamps from the fuel tank.

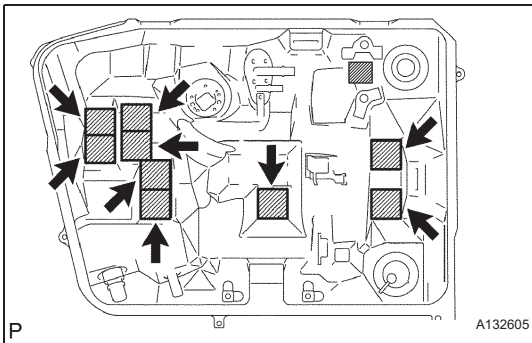

### 18. REMOVE NO. 1 FUEL TANK CUSHION

(a) Remove the 9 cushions from the fuel tank.

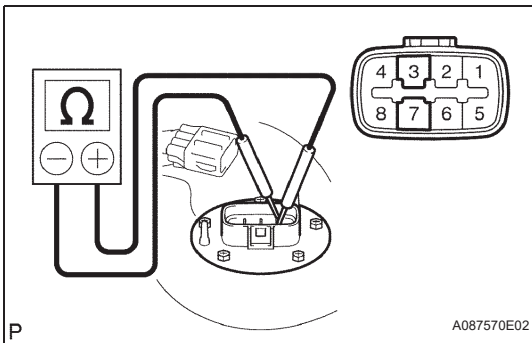

## INSPECTION

### 1. INSPECT FUEL TANK ASSEMBLY WITH FUEL PUMP

(a) Measure the resistance between terminals 3 and 7.

**Standard resistance:**

**0.2 to 3.0  $\Omega$  at 20°C (68°F)**

If the resistance is not as specified, replace the fuel tank assembly.

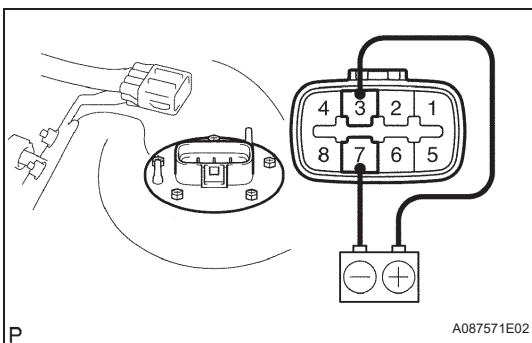

(b) Check that the motor operates when battery voltage is applied across the terminals.

**NOTICE:**

- Perform the check quickly (shorter than 10 seconds).
- Keep the battery as far away the fuel tank as possible.
- Always turn the voltage on and off on the battery side, not the fuel tank side.

If the motor does not operate, replace the fuel tank assembly.

## INSTALLATION

### 1. INSTALL NO. 1 FUEL TANK CUSHION

- (a) Install 9 new cushions to the fuel tank.

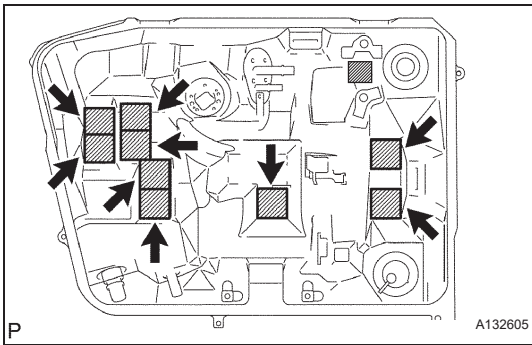

### 2. INSTALL NO. 1 FUEL TUBE CLAMP

- (a) Install the 2 clamps to the fuel tank.

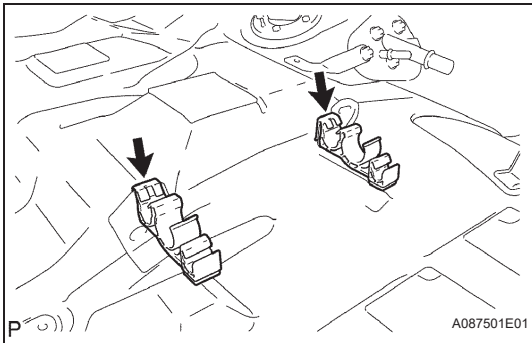

### 3. INSTALL FUEL TANK RETAINER LH

- (a) Install a new gasket to the fuel tank.  
 (b) While being careful that the gasket does not drop in the fuel tank, insert the fuel tank retainer LH to the fuel tank so the protrusion of the fuel tank retainer LH is in the middle of the 2 convex parts of the fuel tank.

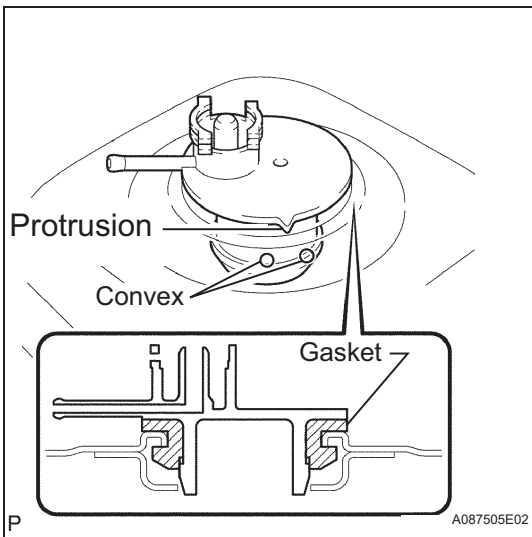

### 4. INSTALL FUEL TANK PRESSURE SENSOR

- (a) Push the fuel tank pressure sensor to the plug of the fuel tank retainer LH, and then install the tube joint clip.

#### NOTICE:

- Check that there are no scratches or foreign objects around the connected part of the fuel tank pressure sensor and fuel tank retainer LH before this procedure.
- Check that the fuel tank pressure sensor is securely inserted to the end.
- Check that the tube joint clip is on the collar of the fuel tank pressure sensor.
- After installing the tube joint clip, check that the fuel tank pressure sensor cannot be pulled out.

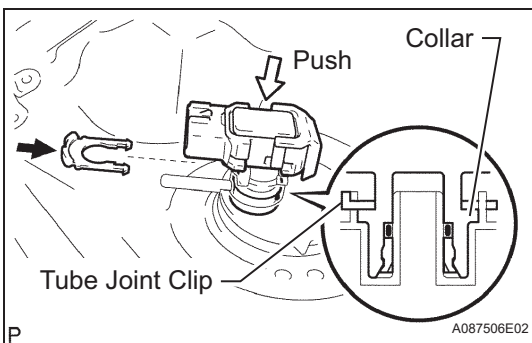

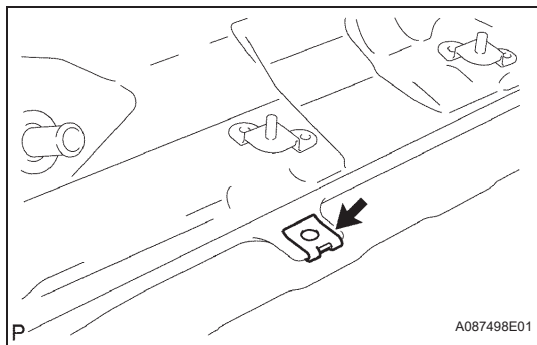

## 5. INSTALL CANISTER

- (a) Install the nut to the fuel tank.

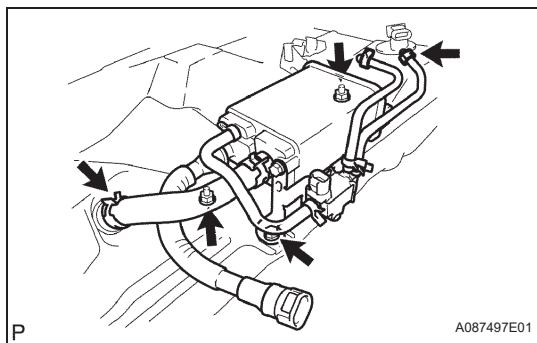

- (b) Install the canister with the bolt and 2 nuts.

**Torque: 6.0 N\*m (61 kgf\*cm, 53 in.\*lbf)**

- (c) Connect the No. 1 canister outlet hose to the fuel tank.  
 (d) Connect the canister hose to the fuel tank retainer.

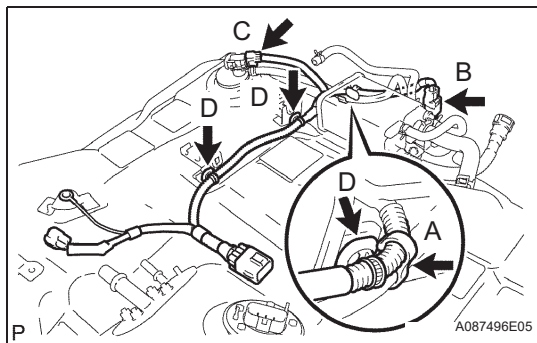

## 6. INSTALL FUEL TANK WIRE

- (a) Install the 3 wire harness clamps as shown in the illustration D.  
 (b) Connect the vapor pressure sensor connector as shown in the illustration C.  
 (c) Connect the VSV connector as shown in the illustration B.  
 (d) Install the clamp as shown in the illustration A.

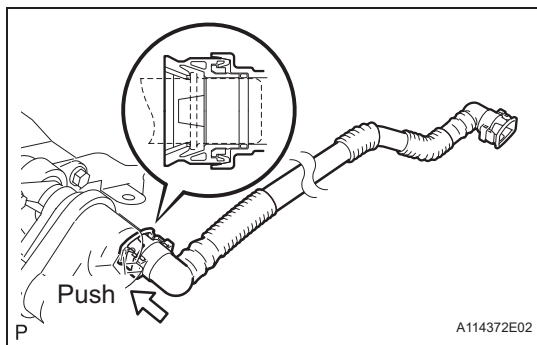

## 7. INSTALL FUEL TANK VENT HOSE

- (a) Align the fuel tank vent hose connector with the pipe, then push in the fuel tank vent hose connector until the retainer makes a "click" sound to install the fuel tank vent hose to the trap canister with pump module.

### NOTICE:

- Check that there are no scratches or foreign objects around the connected part of the fuel tank vent hose connector and pipe before this procedure.
- After connecting the fuel tank vent hose, check that the fuel tank vent hose is securely connected by pulling the fuel tank vent hose connector.

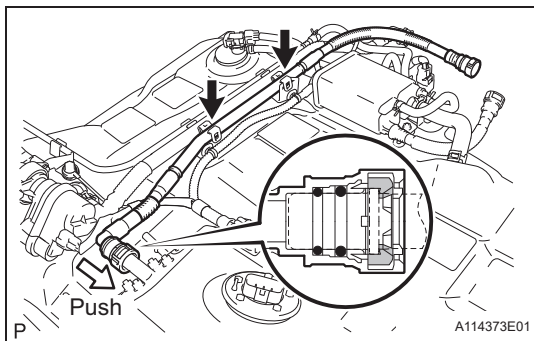
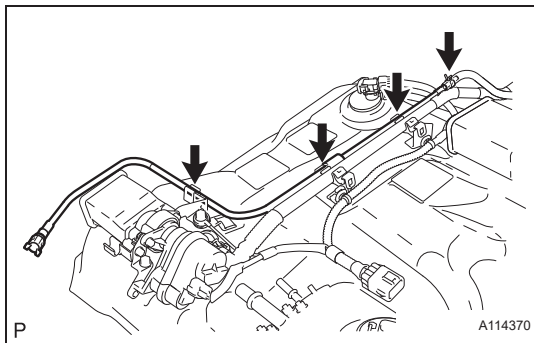
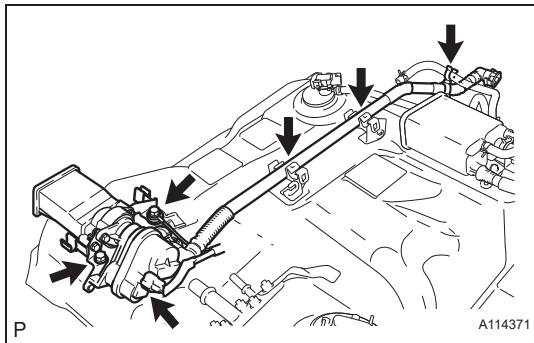
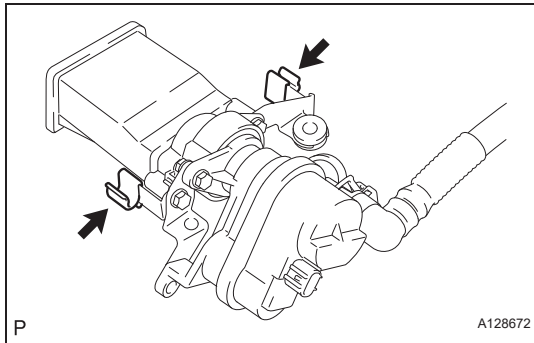
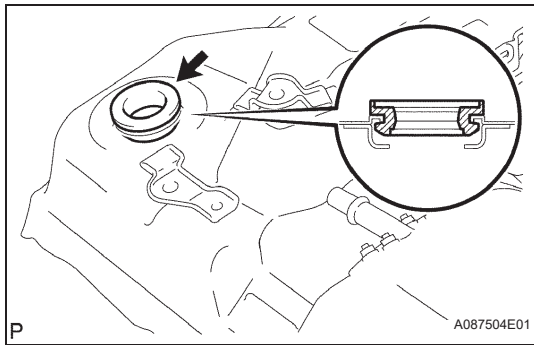

## 8. INSTALL TRAP CANISTER WITH PUMP MODULE

- (a) Install a new gasket to the fuel tank.
- (b) Insert the trap canister with pump module to the fuel tank.

### NOTICE:

**Be careful that the gasket does not drop in the fuel tank.**

- (c) Install the 2 clamps to the trap canister with pump module.

- (d) Install the trap canister with pump module and connect the ground terminal of the fuel tank wire with the 2 bolts.

**Torque: 6.0 N\*m (61 kgf\*cm, 53 in.\*lbf)**

- (e) Install the fuel tank vent hose to the 2 fuel tube clamps.
- (f) Install the clamp to the fuel tank vent hose and canister hose.
- (g) Connect the VSV connector.

## 9. INSTALL FUEL TANK TO CANISTER TUBE

- (a) Install the fuel tank to canister tube to the canister's hose.
- (b) Connect the fuel tank to canister tube to the 2 No. 1 fuel tube clamps.

## 10. INSTALL FUEL SUCTION TUBE SUB-ASSEMBLY

- (a) Align the suction tube connector with the pipe, and then push in the suction tube connector until the retainer makes a "click" sound to install the fuel suction tube to the pipe.

### NOTICE:

- Check that there are no scratches or foreign objects around the connected part of the quick connector and pipe before this procedure.

- After connecting the fuel suction tube, check that the fuel suction tube is securely connected by pulling the suction tube connector.

- Connect the fuel suction tube to the 2 No. 1 fuel tube clamps.

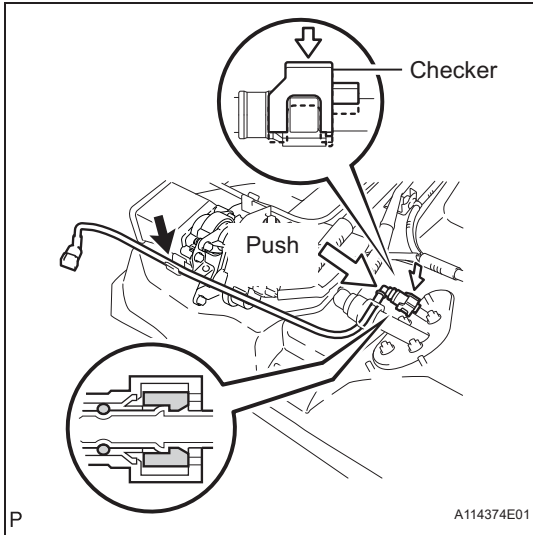

#### 11. INSTALL NO. 2 FUEL TANK MAIN TUBE SUB-ASSEMBLY

- Align the main tube connector with the pipe, and then push in the main tube connector until the retainer makes a "click" sound to install the No. 2 fuel tank main tube to the pipe.

##### NOTICE:

- Check that there are no scratches or foreign objects around the connected part of the fuel tube connector.
- After connecting the No. 2 fuel tank main tube, check that the No. 2 fuel tank main tube is securely connected by pulling the main tube connector.

- Install the checker to the pipe.
- Connect the No. 2 fuel tank main tube to the clamp.

- Connect the connector clamp to the rear fuel tank bracket.

- Install the rear fuel tank bracket with the 3 nuts.

**Torque: 6.0 N\*m (61 kgf\*cm, 53 in.\*lbf)**

#### 12. INSTALL FUEL TANK ASSEMBLY

- Set the fuel tank to a transmission jack.
- Operate the transmission jack, and then install the fuel tank to the vehicle.
- Operate the transmission jack, and then connect the fuel tank inlet pipe.

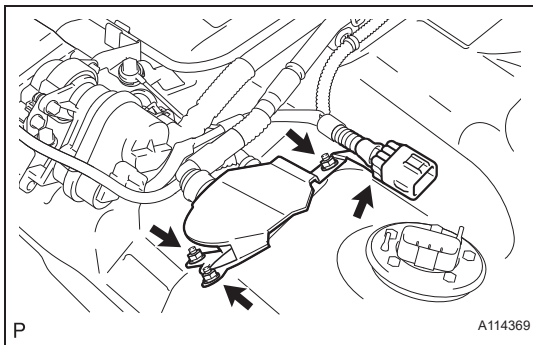

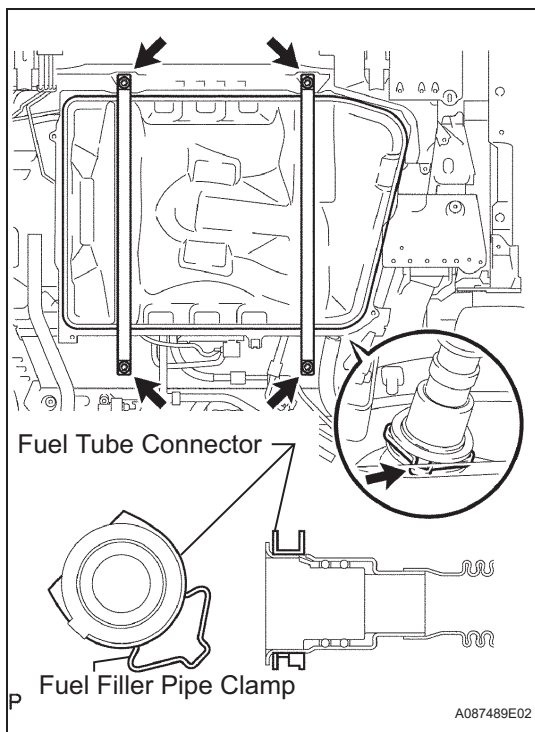

- (d) Install the No. 1 fuel tank band RH and LH with the 4 bolts.

**Torque: 39 N\*m (400 kgf\*cm, 29 ft.\*lbf)**

- (e) Install the fuel tube connector and fuel filler pipe clamp to the fuel tank inlet pipe.

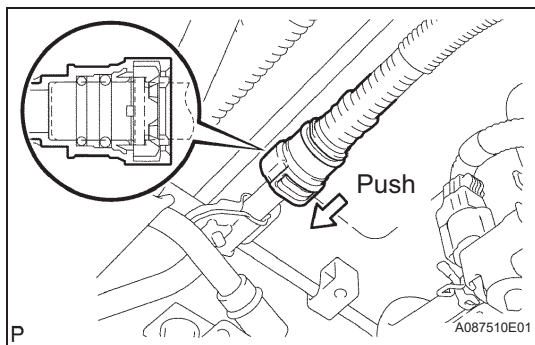

- (f) Connect the No. 1 canister tube.

- (1) Align the No. 1 canister tube connector with the pipe, and then push in the No. 1 canister tube connector until the retainer makes a "click" sound to connect the No. 1 canister tube to the fuel tank to filler pipe.

**NOTICE:**

- Check that there are no scratches or foreign objects around the connected part of the No. 1 canister tube connector and pipe before this procedure.
- After connecting the No. 1 canister tube, check that the No. 1 canister tube is securely connected by pulling the No. 1 canister tube connector.

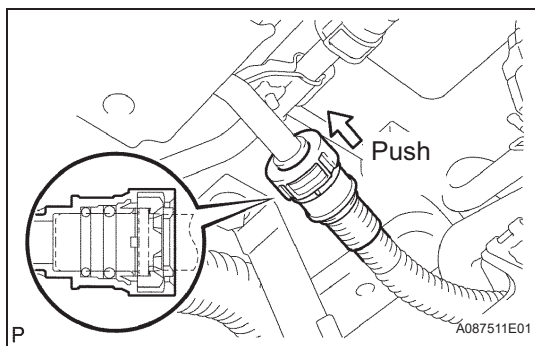

- (g) Connect the fuel suction tube.

- (1) Align the suction tube connector with the pipe, and then push in the suction tube connector until the retainer makes a "click" sound to connect the fuel suction tube to the fuel tank to filler pipe.

**NOTICE:**

- Check that there are no scratches or foreign objects around the connected part of the suction tube connector and pipe before this procedure.
- After connecting the fuel suction tube, check that the fuel suction tube is securely connected by pulling the suction tube connector.



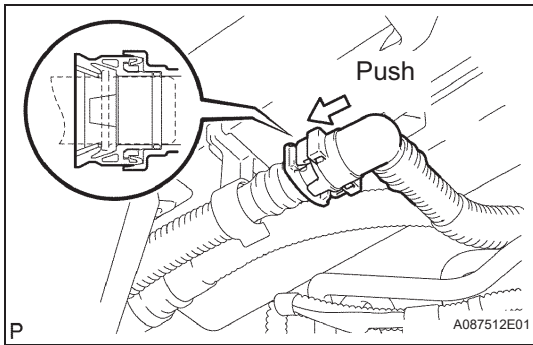

- (h) Connect the fuel tank vent hose.
- (1) Align the fuel tank vent hose connector with the pipe, and then push in the fuel tank vent hose connector until the retainer makes a "click" sound to connect the fuel tank vent hose to the canister filter.

**NOTICE:**

- Check that there are no scratches or foreign objects around the connected part of the fuel tank vent hose connector and pipe before this procedure.
- After connecting the fuel tank vent hose, check that the fuel tank vent hose is securely connected by pulling the vent hose connector.

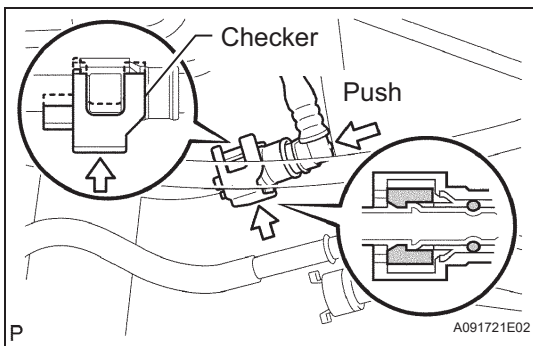

- (i) Connect the No. 2 fuel tank main tube.
- (1) Align the fuel tube connector with the pipe, and then push in the fuel tube connector until the retainer makes a "click" sound to connect the No. 2 fuel tank main tube to the pipe.

**NOTICE:**

- Check that there are no scratches or foreign objects around the connected part of the fuel tube connector and pipe before this procedure.
- After connecting the No. 2 fuel tank main tube, check that the No. 2 fuel tank main tube is securely connected by pulling the quick connector.

- (j) Install the checker to the pipe.

- (k) Connect the fuel tank to canister tube.

- (1) Align the fuel tank to canister tube connector with the pipe, and then push in the fuel tank to canister tube connector until the retainer makes a "click" sound to connect the fuel tank to canister tube to the pipe.

**NOTICE:**

- Check that there are no scratches or foreign objects around the connected part of the fuel tank to canister tube connector and pipe before this procedure.
- After connecting the fuel tank to canister tube, check that the fuel tank to canister tube is securely connected by pulling the quick connector.

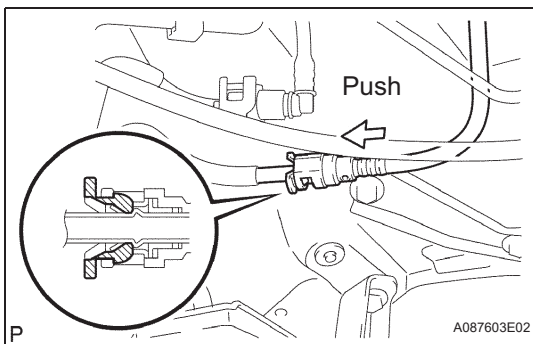

13. INSTALL FRONT EXHAUST PIPE ASSEMBLY (See page [EX-3](#))

14. CONNECT CABLE TO NEGATIVE BATTERY TERMINAL

15. CHECK FOR FUEL LEAKS (See page [FU-8](#))

16. CHECK FOR EXHAUST GAS LEAKS

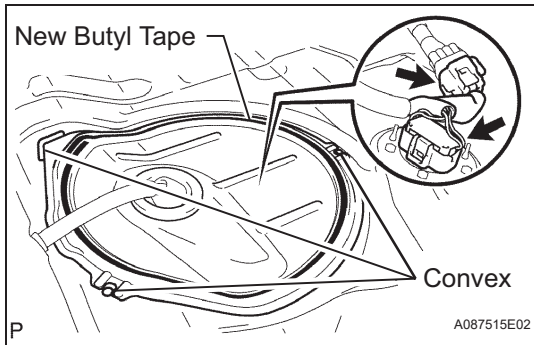

17. INSTALL FRONT FLOOR PANEL BRACE (See page [EX-4](#))
18. INSTALL INSTRUMENT PANEL FINISH PANEL LOWER CENTER (See page [IP-21](#))
19. INSTALL REAR FLOOR SERVICE HOLE COVER
  - (a) Attach new butyl tape to the rear floor service hole cover.
  - (b) Connect the wire to wire connector.
  - (c) Connect the fuel pump connector.
  - (d) Install the rear floor service hole cover while adjusting it to the 3 convex parts of the floor panel.

**NOTICE:**

**Be careful that the rear floor service hole cover does not overlap the convex parts of the floor panel when installing.**

20. INSTALL REAR SEAT CUSHION ASSEMBLY (See page [SE-23](#))
21. PERFORM INITIALIZATION
  - (a) Perform initialization (see page [IN-32](#)).

**NOTICE:**

**Certain systems need to be initialized after disconnecting and reconnecting the cable from the negative (-) battery terminal.**