

VENTILATION VALVE COMPONENTS

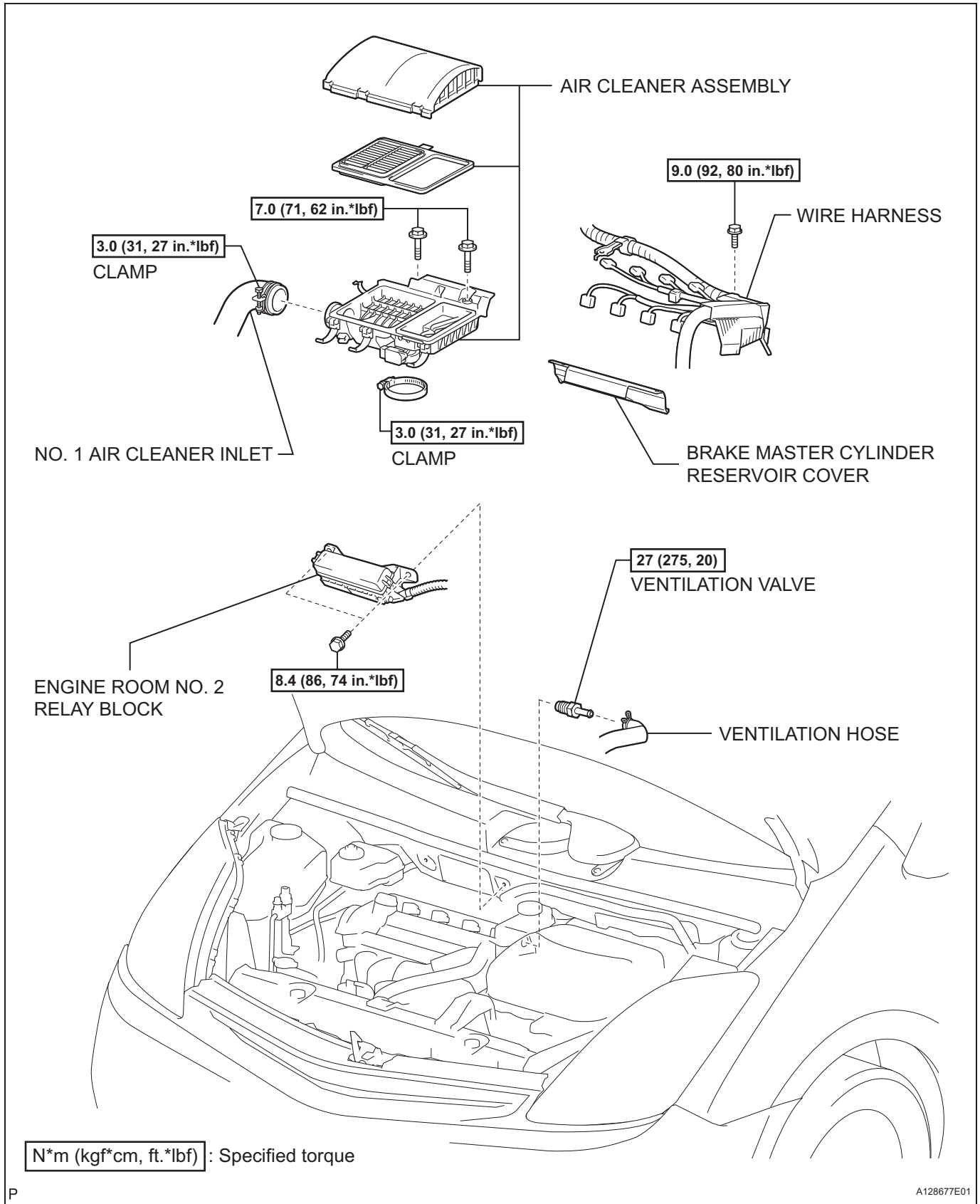

EC

N*m (kgf*cm, ft.*lbf) : Specified torque

REMOVAL

1. REMOVE REAR NO. 2 FLOOR BOARD (See page CH-4)
2. REMOVE REAR FLOOR DECK BOX (See page CH-4)
3. REMOVE REAR NO. 3 FLOOR BOARD (See page CH-4)
4. DISCONNECT CABLE FROM NEGATIVE BATTERY TERMINAL
CAUTION:
 Wait at least 90 seconds after disconnecting the cable from the negative (-) battery terminal to prevent airbag and seat belt pretensioner activation.
5. REMOVE ENGINE ROOM NO. 2 RELAY BLOCK
 - (a) Remove the 2 bolts and relay block.
 - (b) Remove the 4 wire harness clamps.

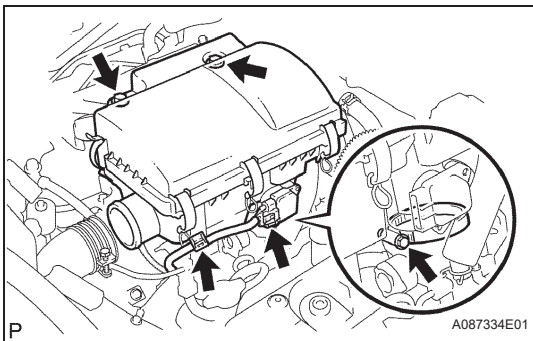
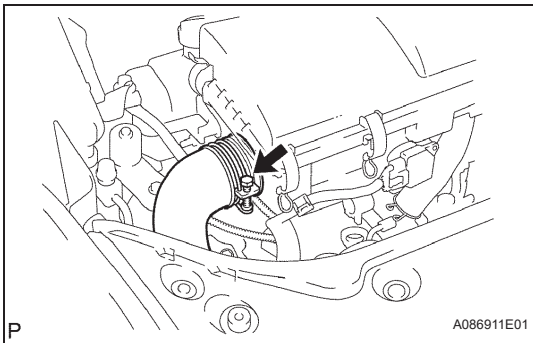
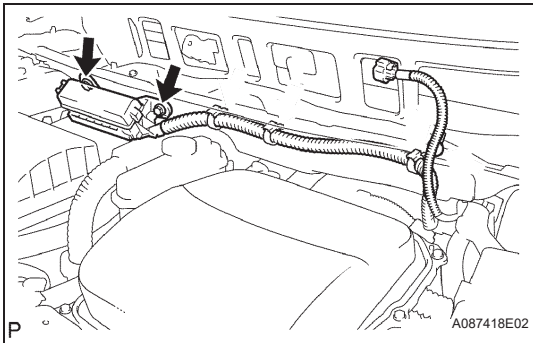

6. REMOVE AIR CLEANER ASSEMBLY
 - (a) Loosen the clamp, then disconnect the No. 1 air cleaner inlet from the air cleaner case.
 - (b) Disconnect the mass air flow meter connector, then remove the wire harness clamp.
 - (c) Loosen the 2 clamps, then remove the 2 bolts and air cleaner assembly.

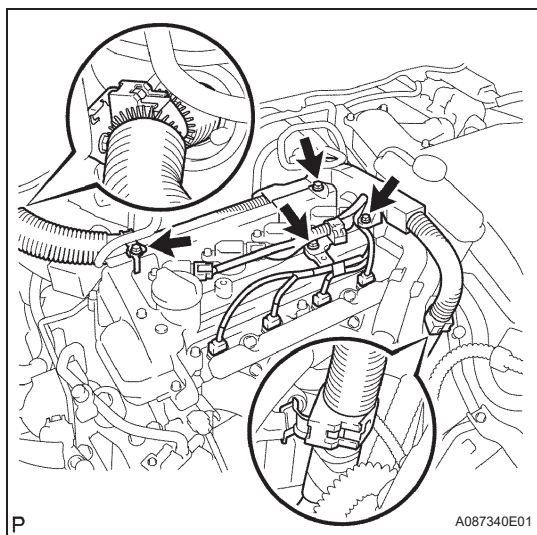

7. REMOVE WIRE HARNESS

- (a) Disconnect the fuel injector connector and ignition coil connector.
- (b) Remove the 3 bolts and wire harness clamp, then disconnect the wire harness.

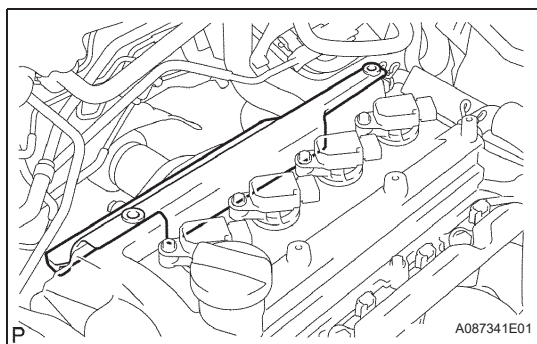

- (c) Remove the brake master cylinder reservoir cover.

EC

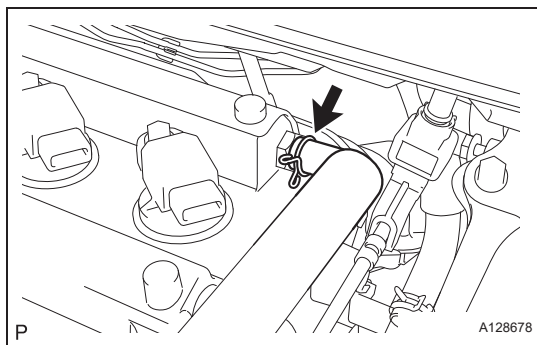

8. REMOVE VENTILATION VALVE

- (a) Disconnect the ventilation hose.
- (b) Remove the ventilation valve.

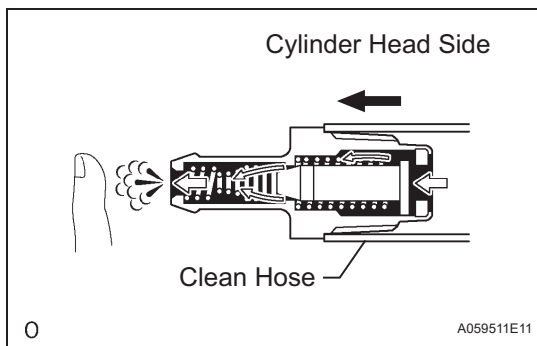

INSPECTION

1. INSPECT VENTILATION VALVE

- (a) Check the ventilation.
 - (1) Install a clean hose to the ventilation valve as illustration.
 - (2) Check that there is ventilation when air is applied to the cylinder head side.

CAUTION:

Do not suck the air inside the ventilation valve because it is harmful.

If there is no ventilation, replace the ventilation valve.

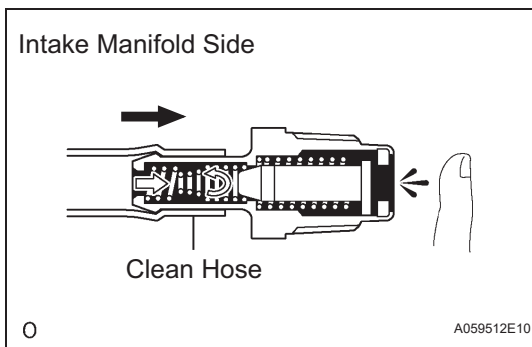

- (3) Check that there no ventilation when air is applied to the intake manifold side. If there is ventilation, replace the ventilation valve.

INSTALLATION

1. INSTALL VENTILATION VALVE

- (a) Install the ventilation valve onto the cylinder head cover.

Torque: 27 N*m (275 kgf*cm, 20 ft.*lbf)

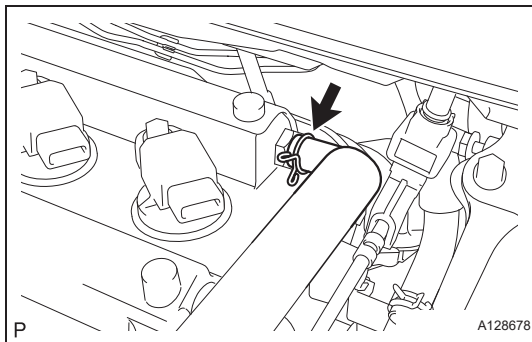

2. INSTALL ENGINE WIRE

- (a) Install the brake master cylinder reservoir cover to the cylinder head cover.

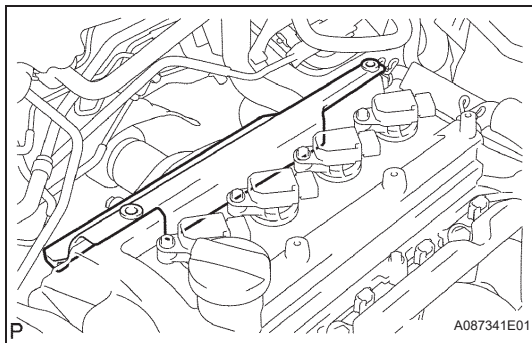

- (b) Install the wire harness and brake master cylinder reservoir cover with the 3 bolts.

Torque: 9.0 N*m (92 kgf*cm, 80 in.*lbf)

- (c) Connect the fuel injector connector and ignition coil connector.

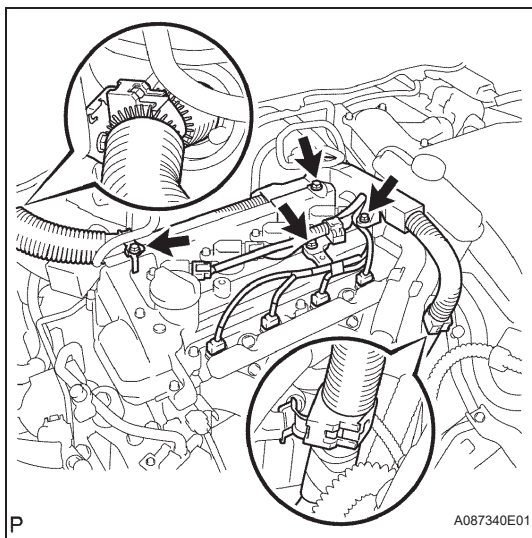

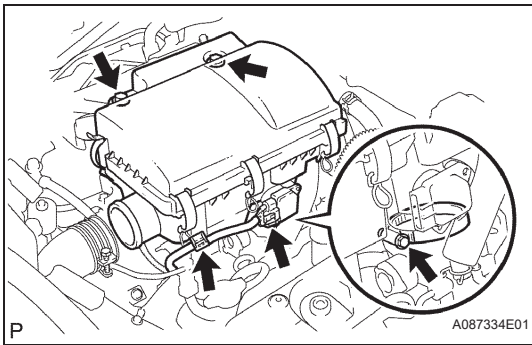

3. INSTALL AIR CLEANER ASSEMBLY

- (a) Install the air cleaner with the 2 bolts and tighten the clamp.

Torque: 7.0 N*m (71 kgf*cm, 62 in.*lbf) for bolt
3.0 N*m (31 kgf*cm, 27 in.*lbf) for clamp

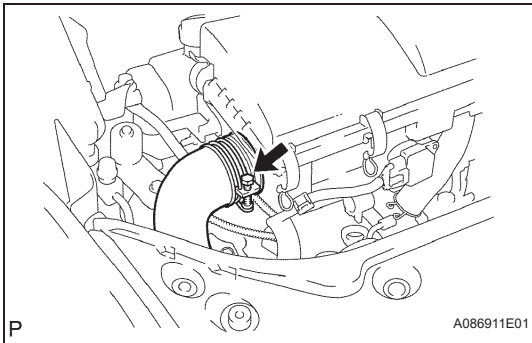

- (b) Connect the No. 1 air cleaner inlet to the air cleaner case, and then tighten the clamp.

Torque: 3.0 N*m (31 kgf*cm, 27 in.*lbf)

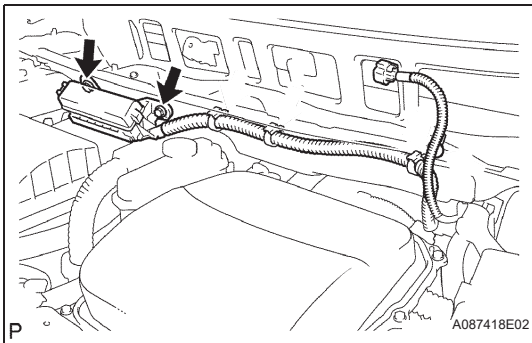

4. INSTALL ENGINE ROOM NO. 2 RELAY BLOCK

- (a) Install the relay block with the 2 bolts.

Torque: 8.4 N*m (86 kgf*cm, 74 in.*lbf)

5. CONNECT CABLE TO NEGATIVE BATTERY TERMINAL (See page CH-7)

6. INSTALL REAR NO. 3 FLOOR BOARD (See page CH-8)

7. INSTALL REAR DECK FLOOR BOX (See page CH-8)

8. INSTALL REAR NO. 2 FLOOR BOARD (See page CH-8)