

GENTEX CONNECTOR TOP VIEW

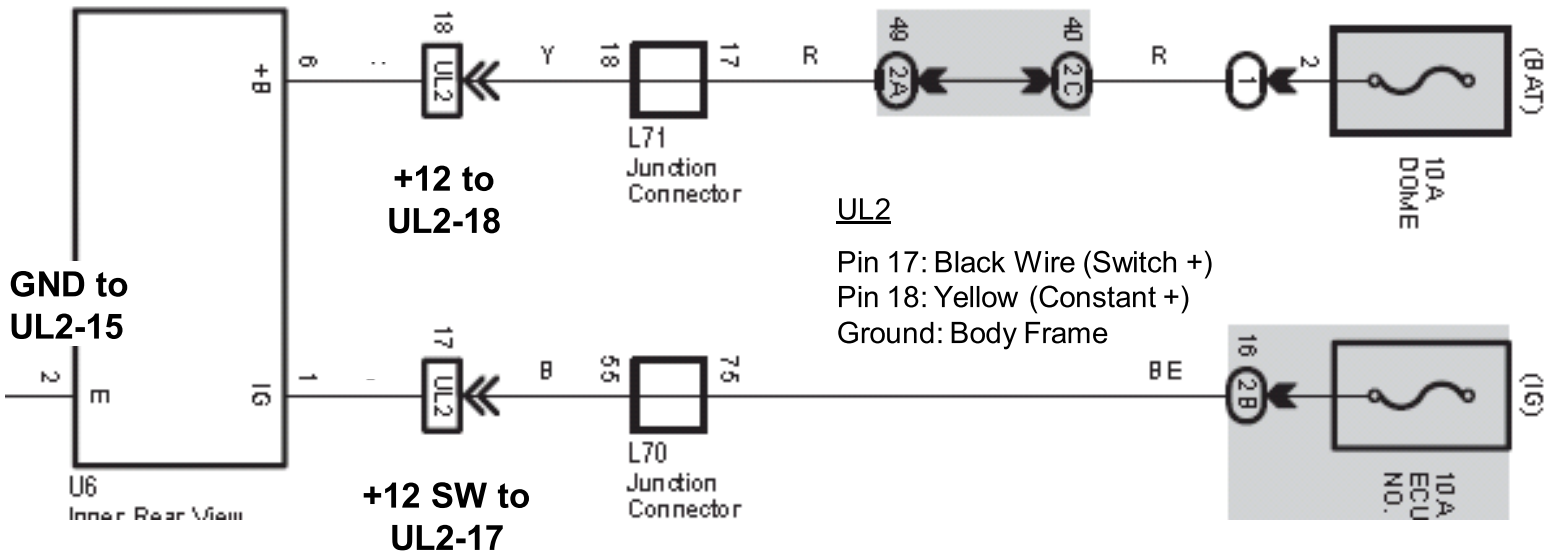
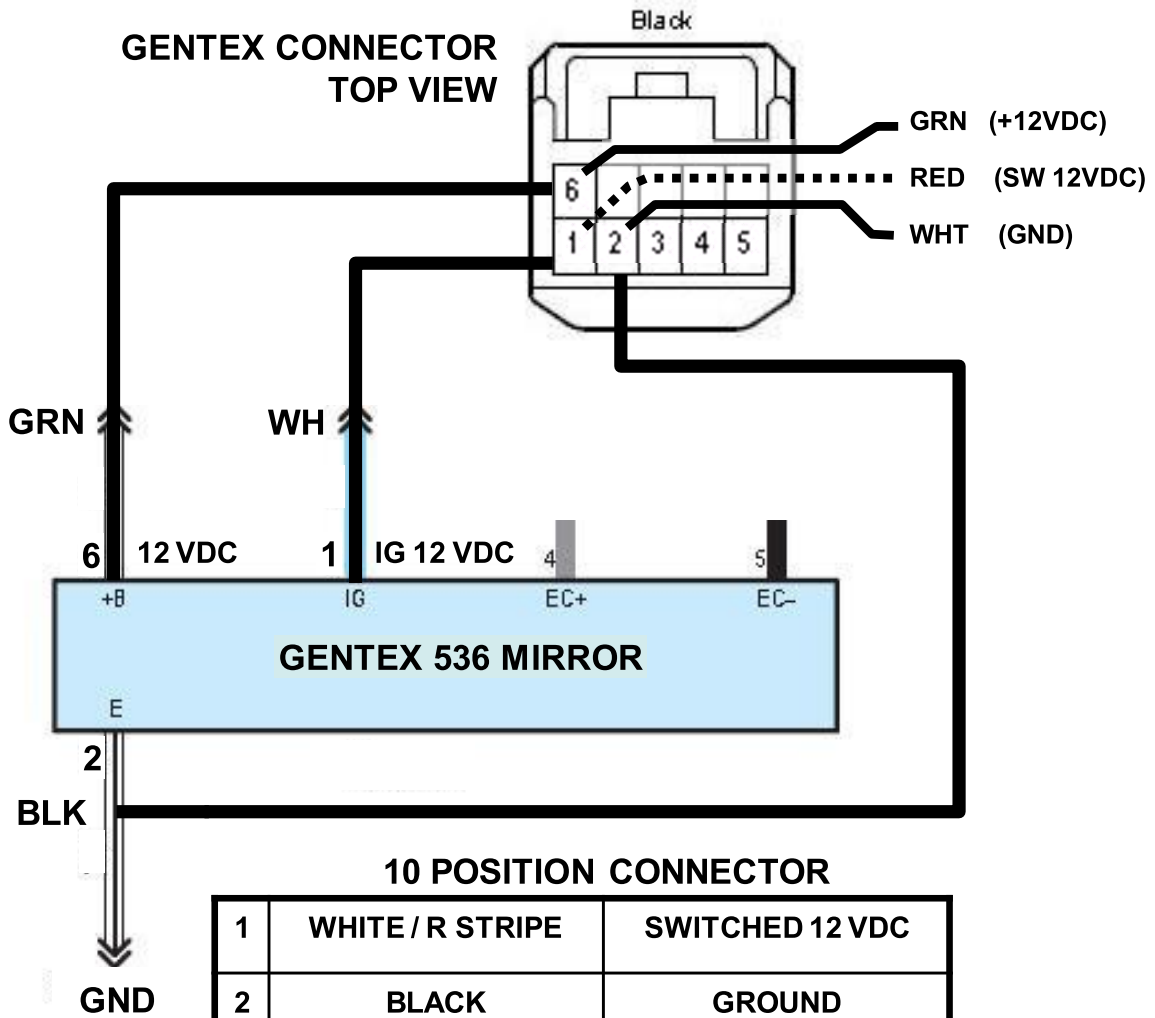

Name: No. 1 Roof Wire and Instrument Panel Wire (Instrument Panel Reinforcement)

Code: UL2

Part Number: 90980-12412/90980-12411

Color: White

Display Wire Harness Repair Info

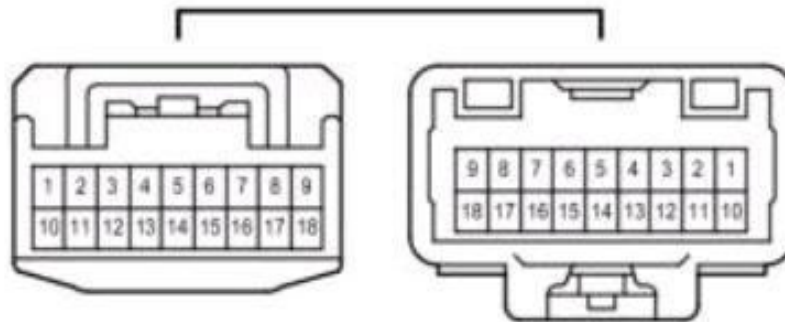

2012 Prius vee connector UL2 above and right has 3 required pins but it's in the dash accessed on driver's side. Constant +12 can be found by "looking at the overhead panel plug ... the far right upper pin."

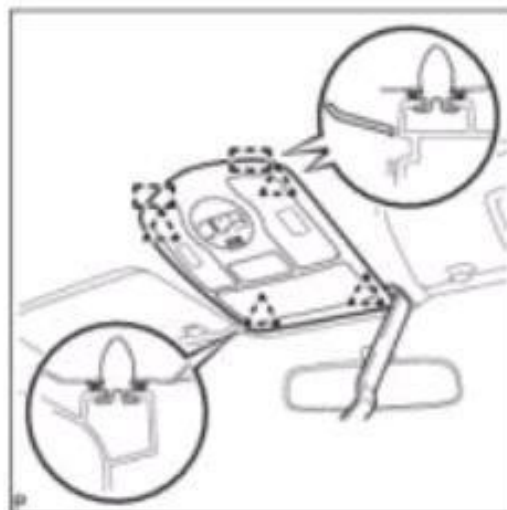
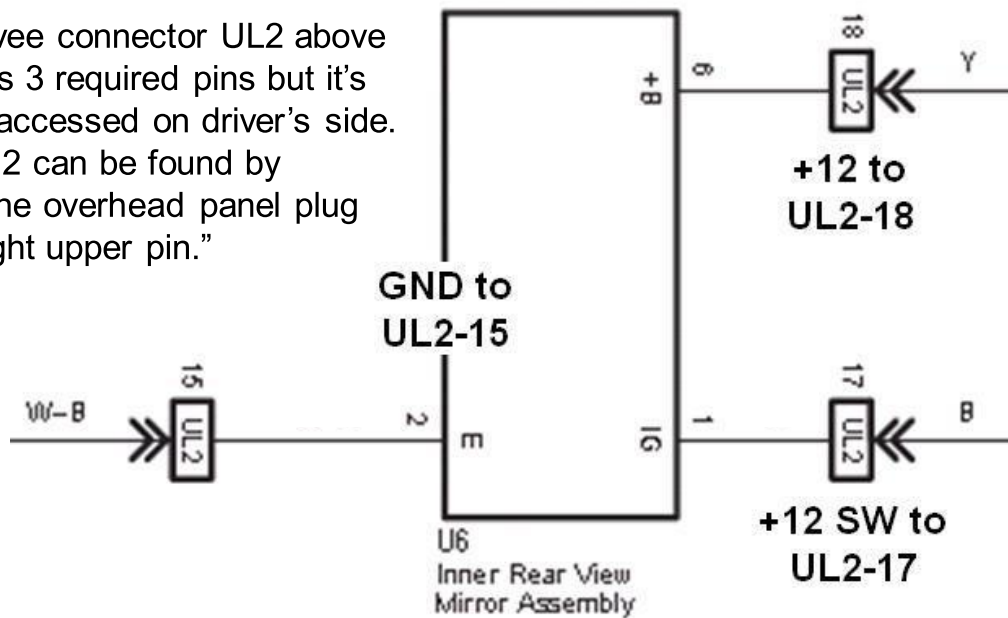

(b) Disconnect the connector and remove t

Door Open
to Gnd

**Map Light PC
Board:**

No pin wiring to 8, 9,
12-14, 16-20
Microphone wiring 2-5
(R, B, W, B)

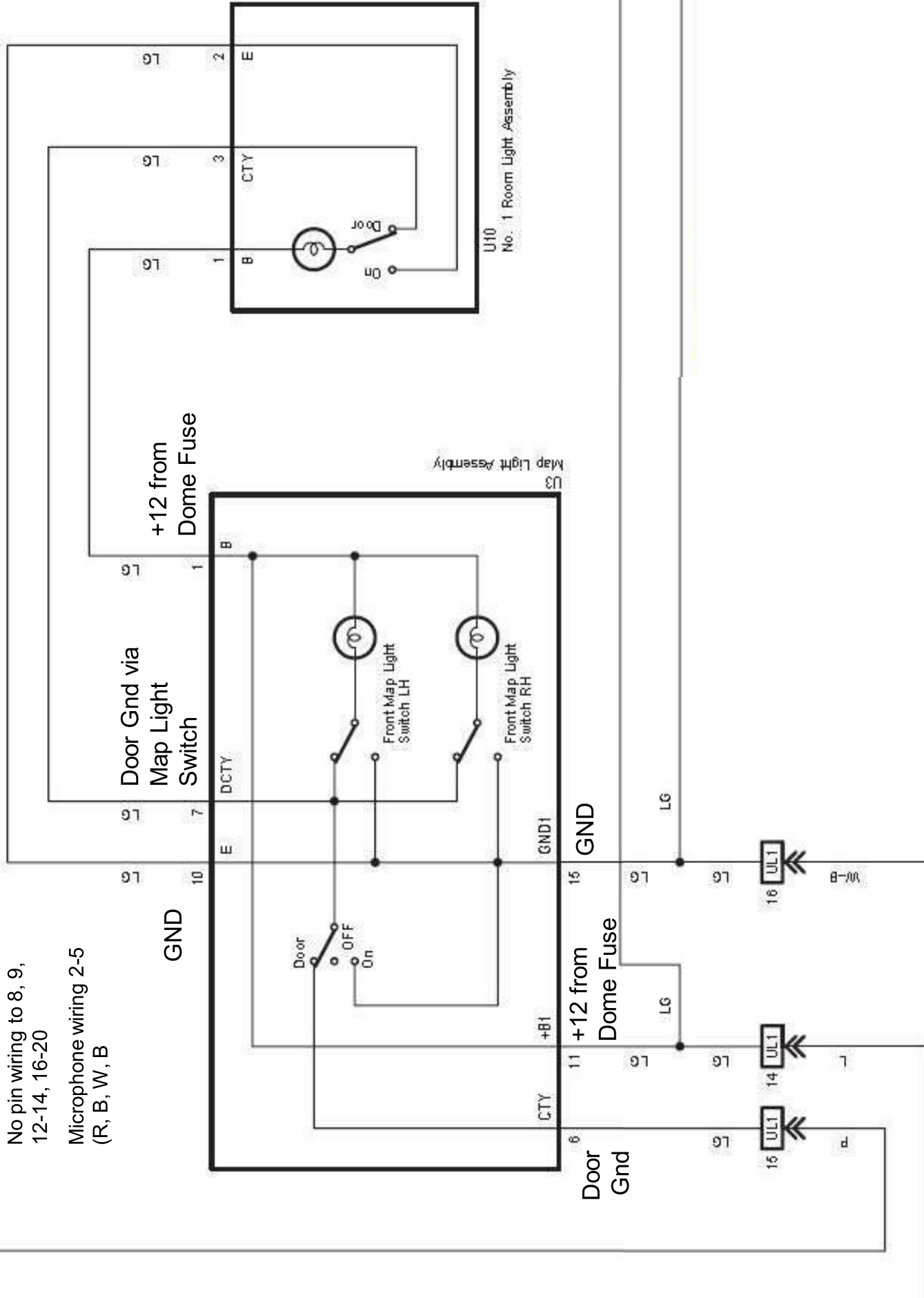

1
52
2A
P

20 Pin Map Light PC Board Connector

Pins 1 and 11 = 12 v

Pins 10 and 15 = Gnd

No Switched 12 v

No pin wiring to 8, 9, 12-14, 16-20. Microphone Pins 2-5

UL1 Is located in the dash not the headliner. A 20 pin connector (U3) is behind the Maplight and is only shown as pin numbers below and are adjacent to the map light schematic box (eg **PIN 10 GND**). Use U3 Cable for Power.

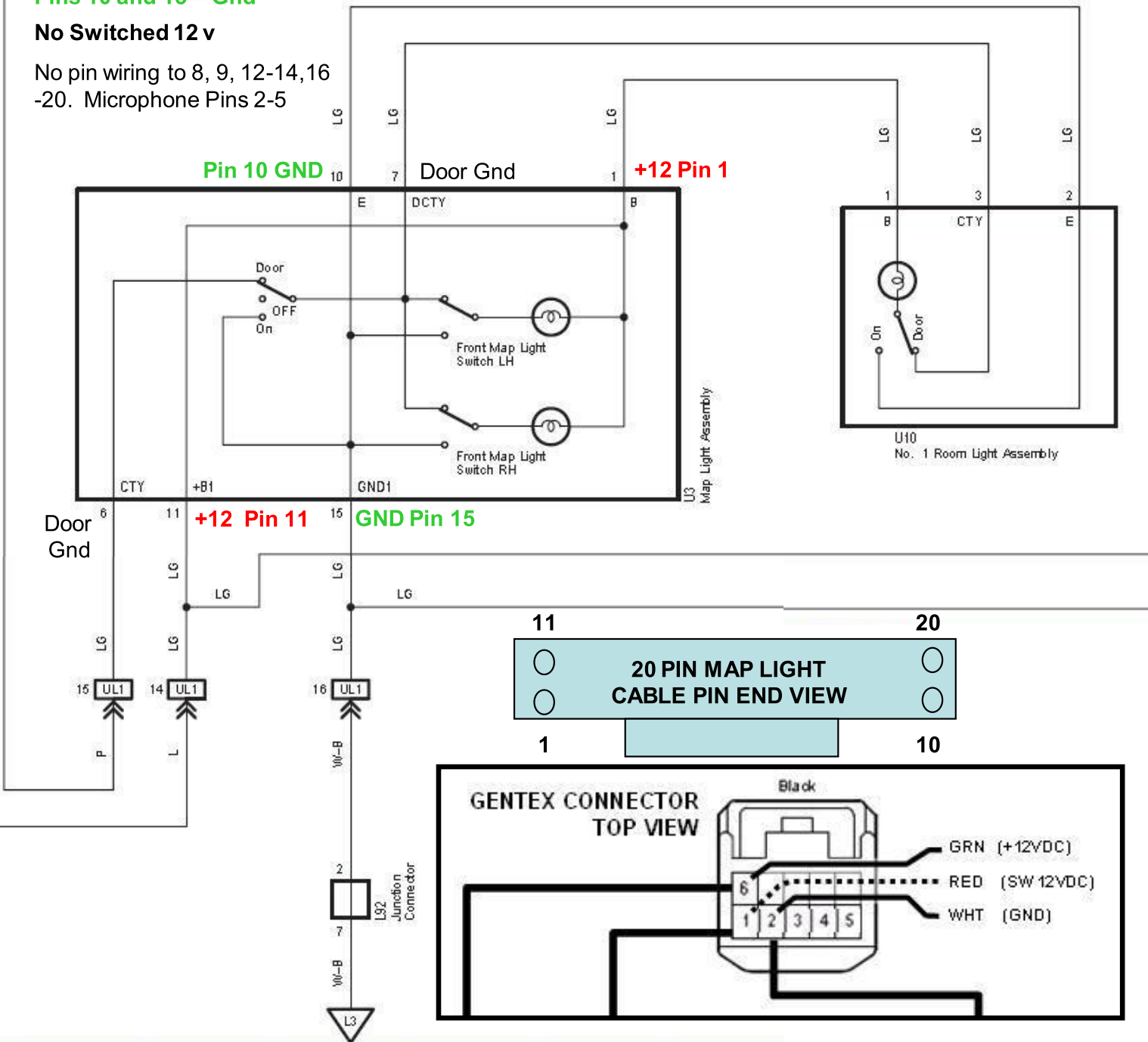

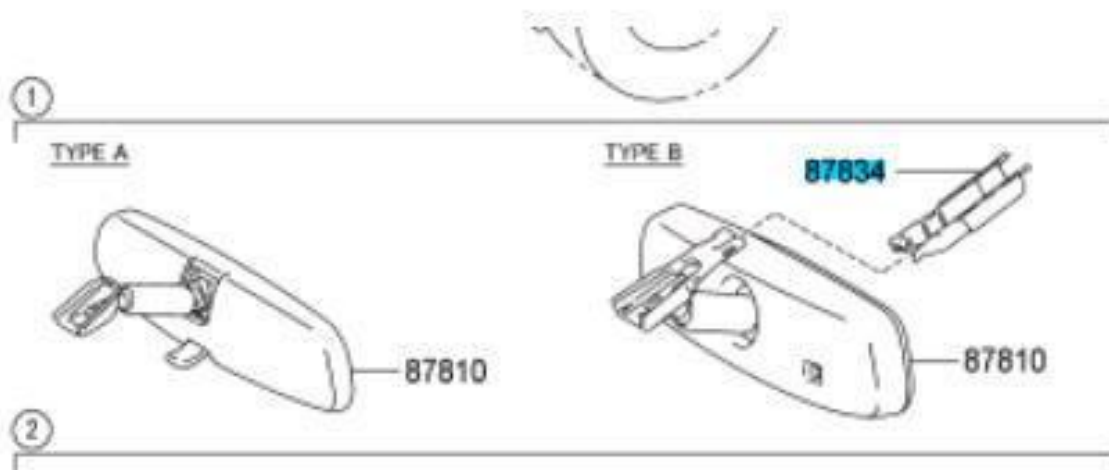

That part is 87818-0C020 which retails for \$4.42. If ordered online you'll save a bit and the sale price would be \$3.40.

Thank you,

Mr. Jamie Sutherland
TRDSparks.com
Internet Parts Manager
4855 Hwy 501
Myrtle Beach, SC 29579

Toll Free # [1-866-249-3607](tel:1-866-249-3607)

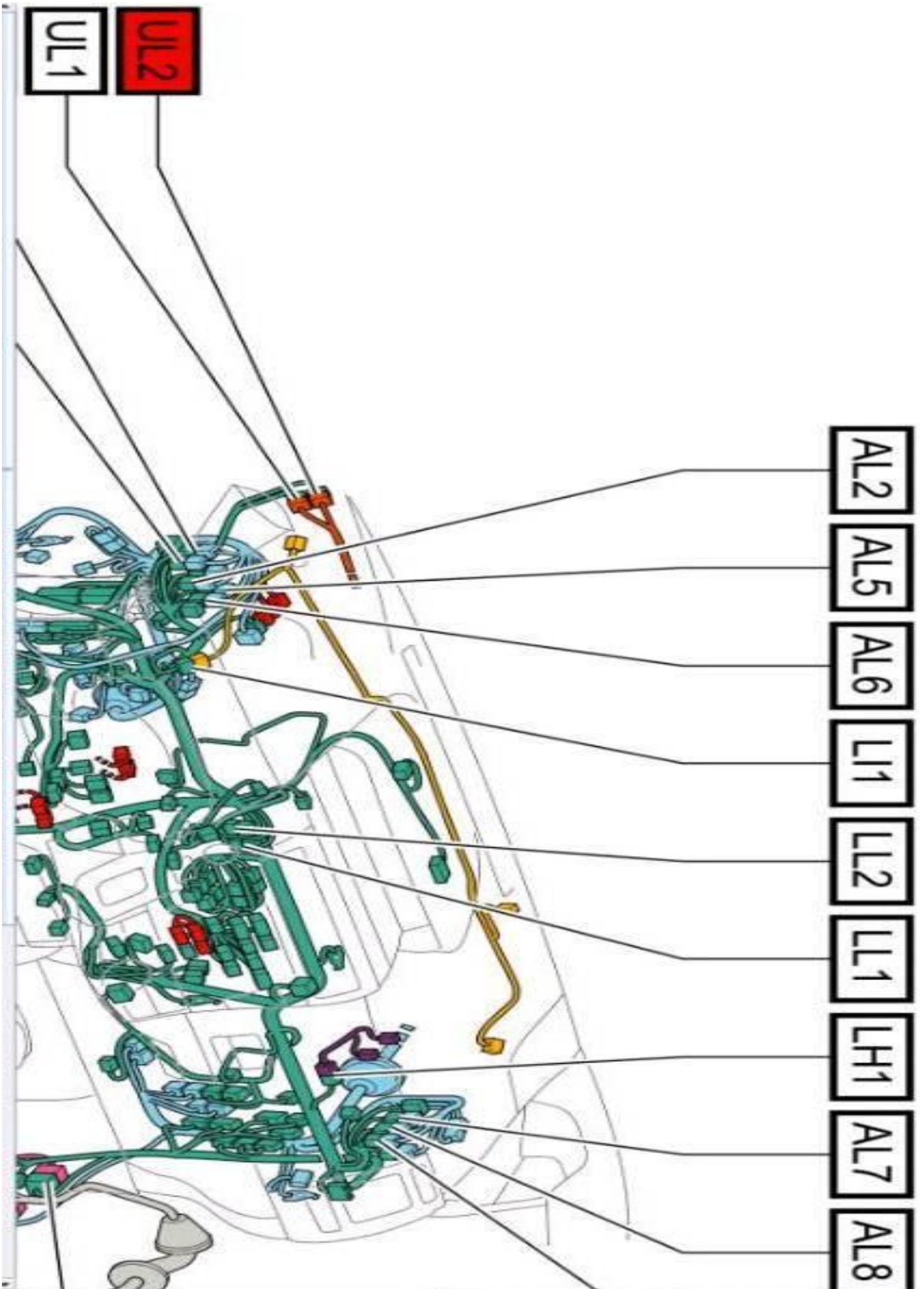



Installed Gentex 453.

REMOVAL Tip #1

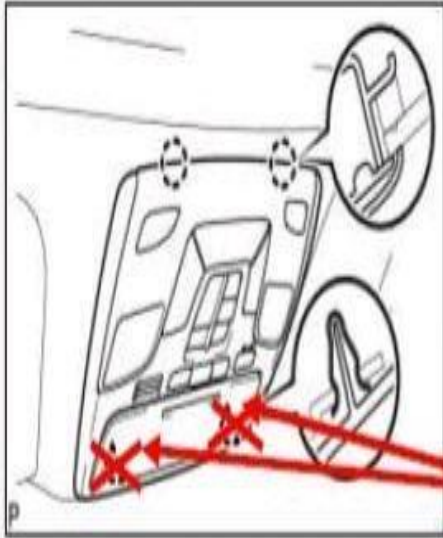

1. REMOVE ROOF CONSOLE BOX ASSEMBLY

- (a) Disengage the 2 claws and 2 clips and remove the roof console box.

Do not pull down on the front edge of the Console Box. It may distort or crack if these areas are used to remove the Console Box

REMOVAL Tip #2

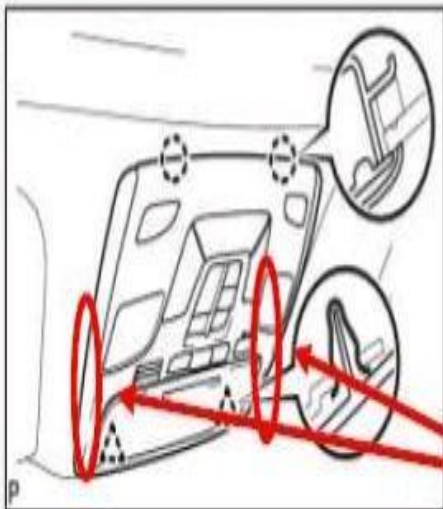

1. REMOVE ROOF CONSOLE BOX ASSEMBLY

- (a) Disengage the 2 claws and 2 clips and remove the roof console box.

Pull down on the sides of the Console Box to disengage the 2 clips.



Locate push in points and pry downward.



Removal tool

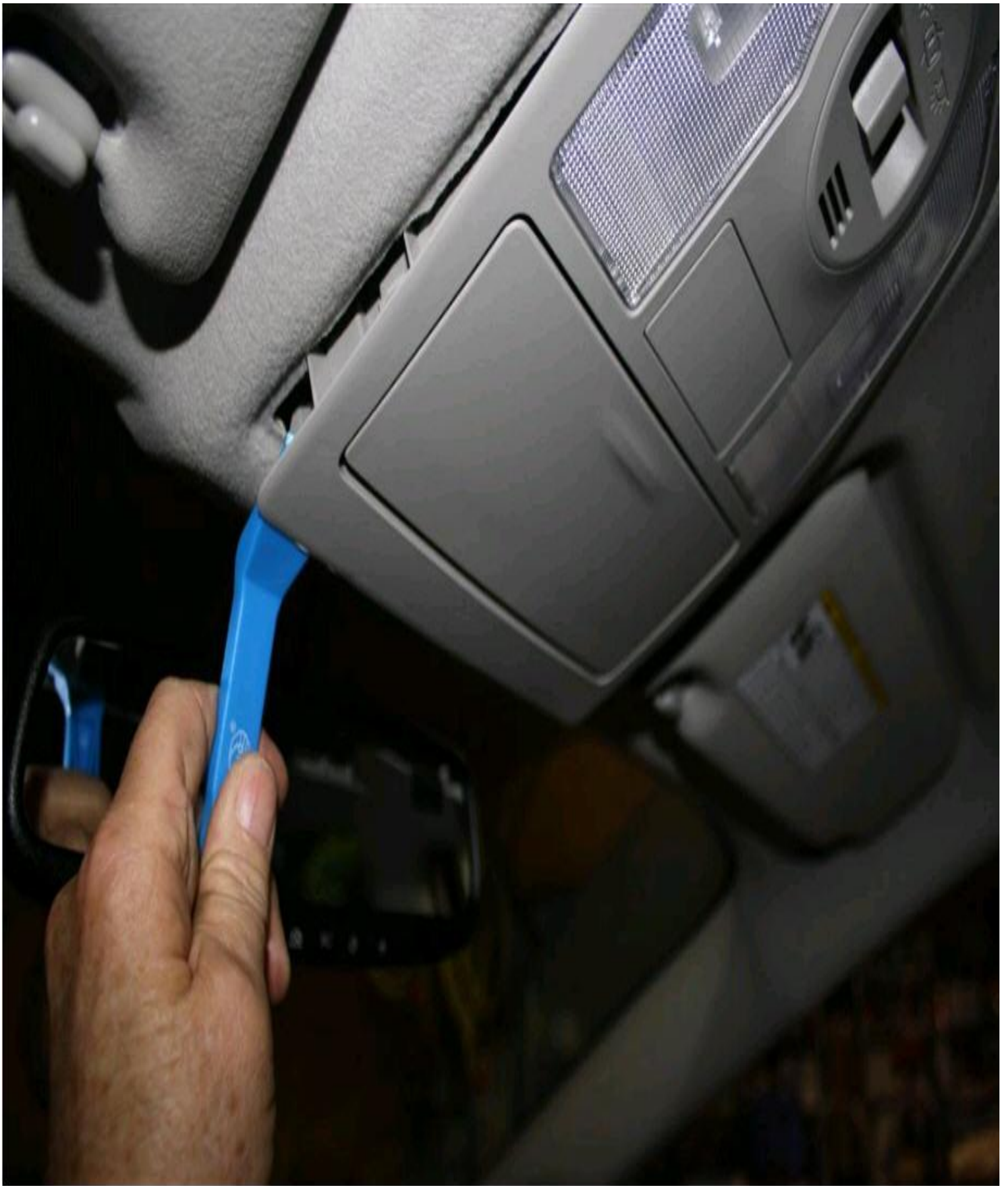

Once first retainer pops move to the right. There are two more on the rear.



Plastic trim tools. Harbor Freight or Northern Tool.



Back side of visor with metal clips in place.

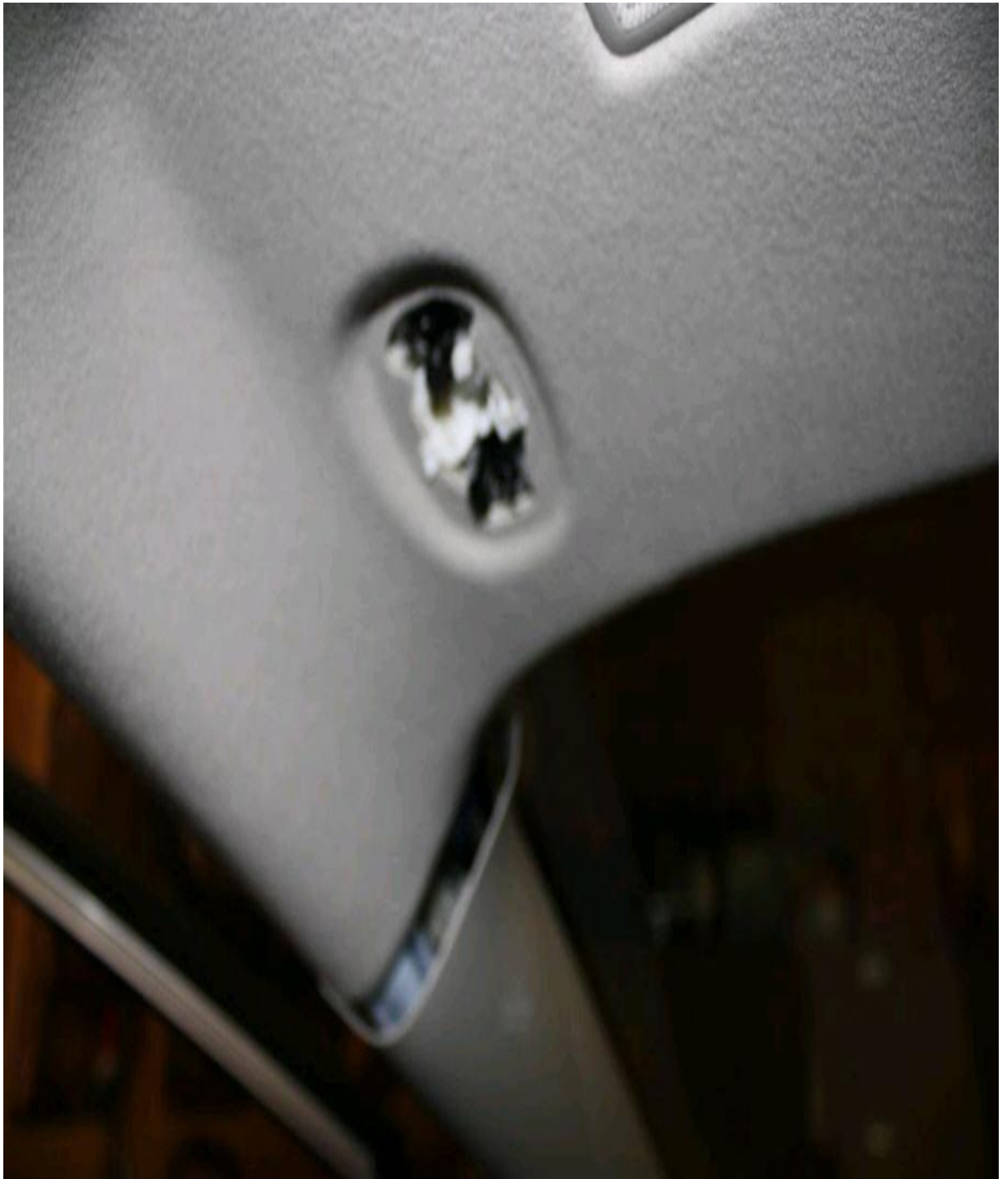

Sun Visor also removes in two parts. Remove retainer cover then remove visor. Notice black metal clips in mounting area. These have to be removed and re installed in visor base. Be careful as then can go through the hole into the void behind headliner.



Sun Visor holder. Removes by turning counter clockwise. Once removed press clips on base to remove.

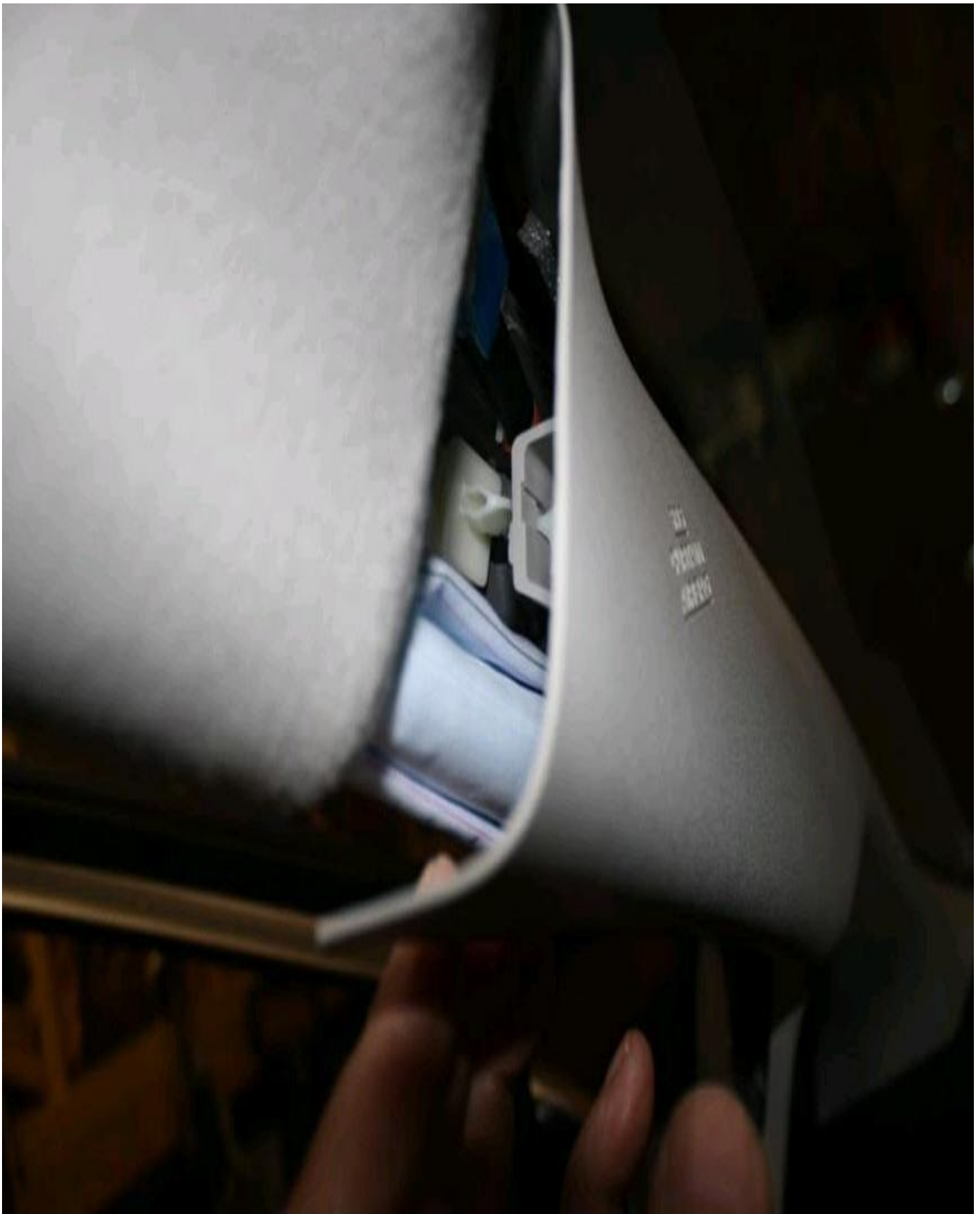

pillar trim at center top but do not remove. Once it is popped it will remain in place with a hook device. This is the retainer to hold the panel if the air is deployed. See next photo.

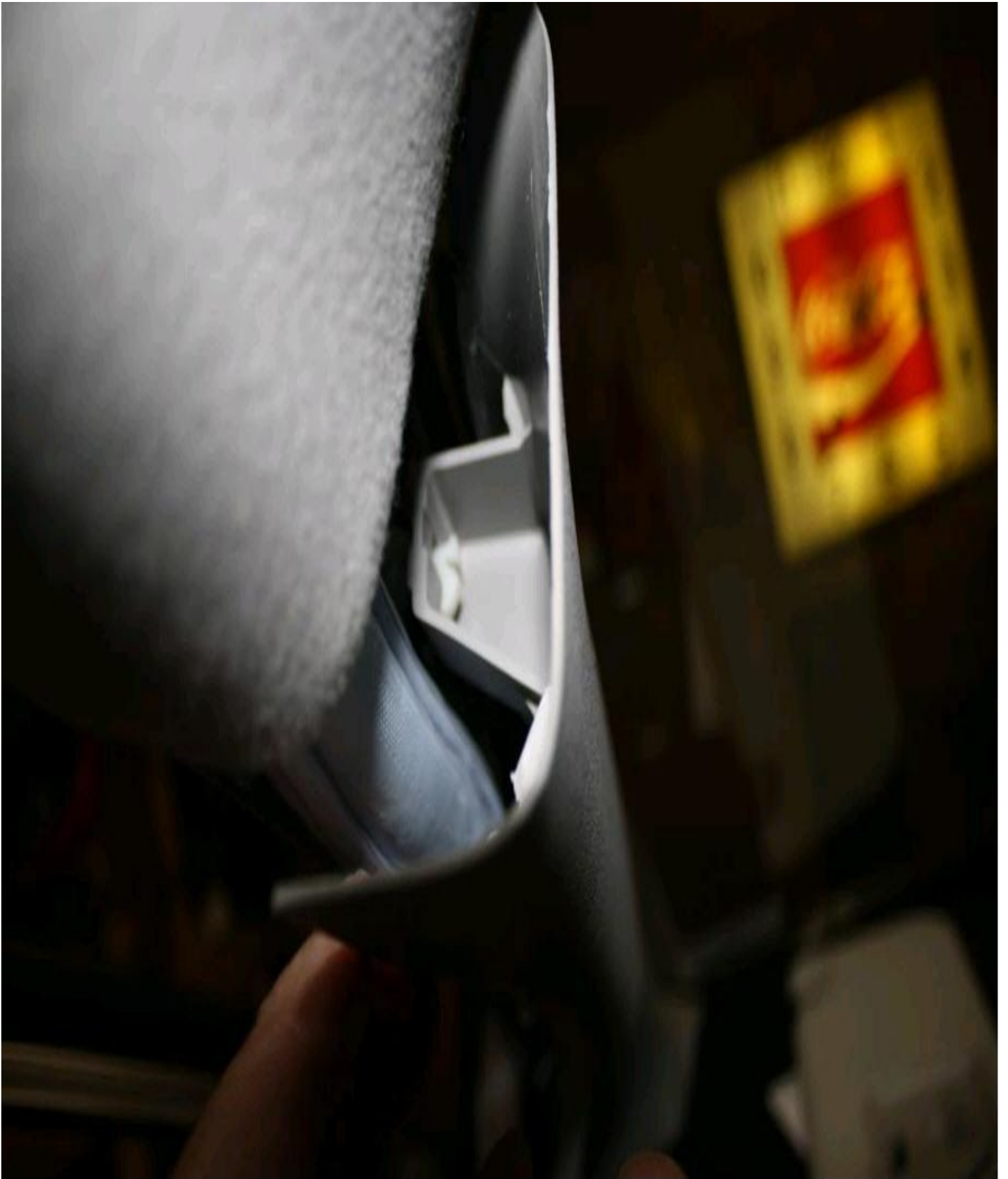

Pillar panel retainer hook. Do not disengage.

kennethfuller@juno.com

Junior Member

Join Date: Dec 2011

Location: Texas

Posts: 3

My Car: 2005 Prius

Model: Five

Package: Navigation

Thanks: 0

Thanked 0 Times in 0 Posts

Friends: [0](#)**Re: Help with Gentex Wiring**

Quote:

Originally Posted by **Flyabus** 
*Hi. I am eagerly awaiting an answer. I have the exact same issue. Thanks
George*

Flyabus.

Job is completed and not that bad. I posted some photographs in my album on my profile site. Just left click on my user name and then go to albums.

I found that acquiring proper tools made the removal of the panel much easier. Northern Tool or Harbor Freight plastic trim panel removal tools for less than ten bucks. Photo of tools in my photo album. I, like you, was very concerned about damaging the panel. Once the retainer popped it was a piece of cake.

I obtain ground by self tapping screw in side of panel frame. Found constant 12V power in overhead panel plug using test light. The keyed 12V was a little more difficult but not bad. Removed the visor, visor holder and pulled down the rubber trim around the door. I did not remove the pillar trim. I ran two wires, one for 12V switched power and one for reverse power to remove dimming from mirror when in reverse. I routed the wires behind the side curtains and then down the door frame replacing the rubber trim to hold in place. I obtained 12V switched power from the fuse box power port fuse. That would be the cigar lighter from us old folks.

I haven't found reverse power yet but will post when found.

I hope this and the photographs help. If you have questions e-mail me or ask here.

(PS - Since I'm new here I do not have photo posting privileges in the forum thus the photographs are posted in my album - sorry)

Last edited by kennethfuller@juno.com; Today at 09:28 AM.



Help with Gentex Wiring

Just took possession of my 2012 Prius v III without Gentex Auto Dim/Homelink rear view mirror. I've purchased a Gentex 453 015894 homelink/compass but am unable to identify the wiring.

The connector is a ten pin with six wires. Black, Yellow/Red, Green/White, Violet/Red, Green/Brown and Blue/Brown.

I've found two sites which identified the wiring but are not the same. Here are the two results:

Black-Ground
Purple-ACC 12V Power
Green with White-Reverse Lights
Green with Brown-Temp Sensor
Blue with Brown-Temp Sensor
Yellow with Red-Constant 12V Power

and

Black-Ground
Violet with Red-Negative Ambient Temp Sensor
Green with White-Reverse Lights (didn't use)
Green with Red-Positive Ambient Temp Sensor
Blue with Red-Ignition Switched 12V Power
Yellow with Red-Constant 12V Power

Any thoughts as it appears either the Blue/Red or Purple is 12V.