

# FUEL SYSTEM

## PRECAUTION

### 1. PRECAUTION

- (a) Before working on the fuel system, disconnect the cable from the negative (-) battery terminal.

**CAUTION:**

**Wait at least 90 seconds after disconnecting the cable from the negative (-) battery terminal to prevent airbag and seat belt pretensioner activation.**

- (b) Do not work on the fuel system near fire. Never smoke while performing work.  
 (c) Keep rubber or leather parts away from gasoline.

### 2. DISCHARGE FUEL SYSTEM PRESSURE

**CAUTION:**

- Before removing the fuel system parts, take precautions to prevent gasoline spillage.
- As some pressure remains in the fuel line even after taking precautions to prevent gasoline spillage, use a shop rag to prevent gasoline from spilling when disconnecting the fuel line.

- (a) Set the vehicle to the "INSPECTION MODE1" (see page [IN-34](#)).

- (b) Disconnect the cable from negative (-) battery terminal.

**CAUTION:**

**Wait at least 90 seconds after disconnecting the cable from the negative (-) battery terminal to prevent airbag and seat belt pretensioner activation.**

- (c) Remove the rear seat cushion (see page [SE-15](#)).  
 (d) Remove the rear floor service hole cover.

- (e) Disconnect the fuel pump connector.  
 (f) Connect the cable to the negative (-) battery terminal.

- (g) Start the engine.  
 (h) After the engine stops (rough idle), turn the power switch OFF.

**HINT:**

DTC P0171 (system to lean) may be present.

- (i) Crank the engine again, then check that the engine does not start.  
 (j) Remove the fuel tank cap, then discharge the pressure in the fuel tank completely.  
 (k) Disconnect the cable from the negative (-) battery terminal.  
 (l) Connect the fuel pump connector.  
 (m) Install the rear floor service hole cover.  
 (n) Install the rear seat cushion (see page [SE-23](#)).  
 (o) Connect the cable to the negative (-) battery terminal..

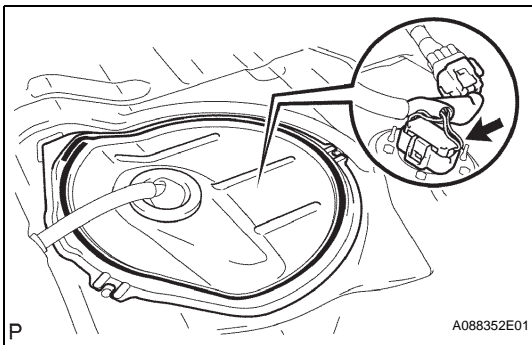

- (p) Perform initialization (see page [IN-32](#)).

**NOTICE:**

**Certain systems need to be initialized after disconnecting and reconnecting the cable from the negative (-) battery terminal.**

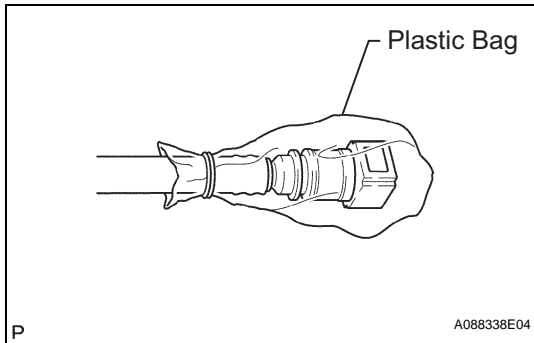
**3. FUEL SYSTEM**

- (a) When disconnecting the high-pressure fuel line, a large amount of gasoline will spill out. So take the following precautions.
- (1) Discharge the fuel system pressure (see step DISCHARGE FUEL SYSTEM PRESSURE).
  - (2) Disconnect the fuel pump tube.
  - (3) Drain the pressure remaining in the fuel pump tube.
  - (4) Cover the disconnected fuel pump tube (fuel tube joint and fuel tube connector) with a plastic bag to prevent damage and intrusion of foreign objects.

- (b) Take the following precautions when removing and installing the fuel injector.
- (1) Do not reuse the O-ring.
  - (2) Do not damage a new O-ring when installing it to the fuel injector.
  - (3) Before installing a new O-ring, apply spindle oil or gasoline.

**NOTICE:**

**Do not use engine oil, gear oil or brake oil.**

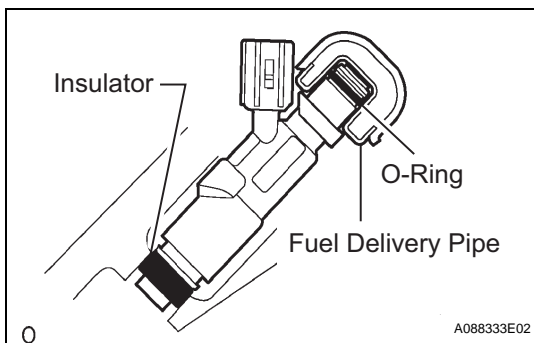
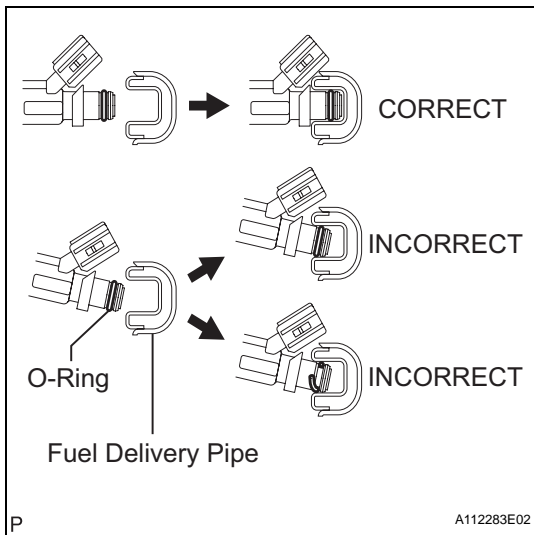

- (c) Install the fuel injector to the fuel delivery pipe and cylinder head as illustrated.

**NOTICE:**

**Apply spindle oil or gasoline to the contact surface of the fuel delivery pipe and fuel injector before installing the fuel injector.**

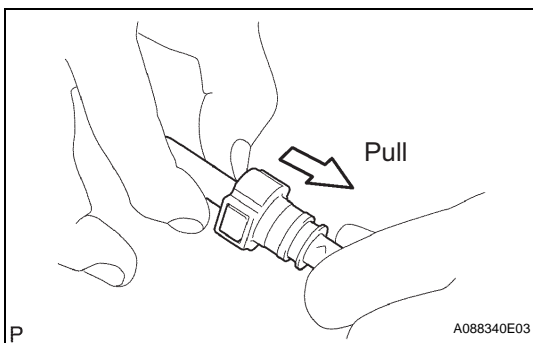
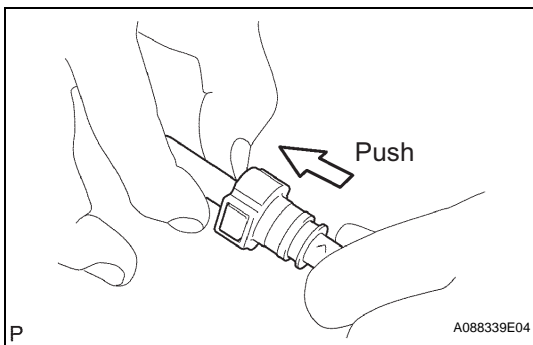
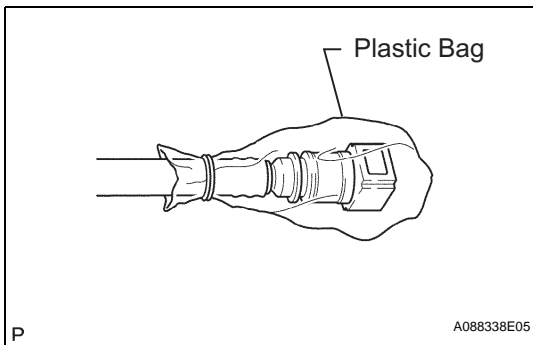
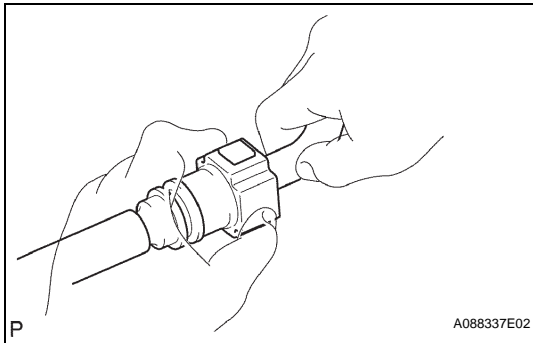
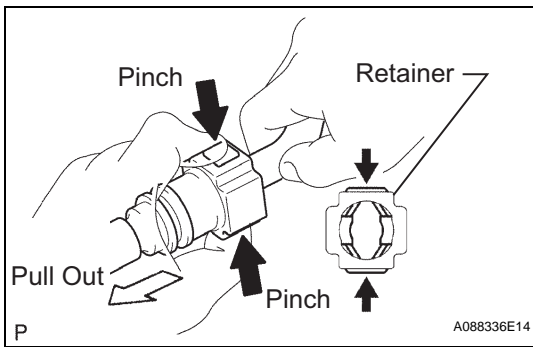

- (d) Take the following precautions when removing the fuel tube connector (Type A).
- (1) Check the fuel tube connector and pipe for dirt or mud before removing the fuel tube connector. If they are dirty, wipe them off with a shop rag.
  - (2) Pinch the retainer as illustrated, then pull out the fuel tube connector from the pipe.

- (3) If the fuel tube connector and pipe are stuck, pinch the pipe, then push and pull the fuel tube connector to release and disconnect the fuel tube connector.

**NOTICE:**

**Do not use any tools.**

- (4) After removing the fuel tube, check the sealing surface of the pipe for dirt or mud. If it is dirty, wipe it off with a shop rag.
- (5) Cover the disconnected fuel tube connector and pipe with a plastic bag to prevent damage and intrusion of foreign objects.

FU

- (e) Take the following precautions when installing the fuel tube connector (Type A).

- (1) Align the fuel tube connector with the pipe, then push in the fuel tube connector until the retainer makes a "click" sound.

**HINT:**

If they are connected too tightly, apply a light coat of engine oil to the tip of the pipe, then install the fuel tube connector.

- (2) After connecting the fuel tube connector, check that the fuel tube connector and pipe are securely connected by pulling them.

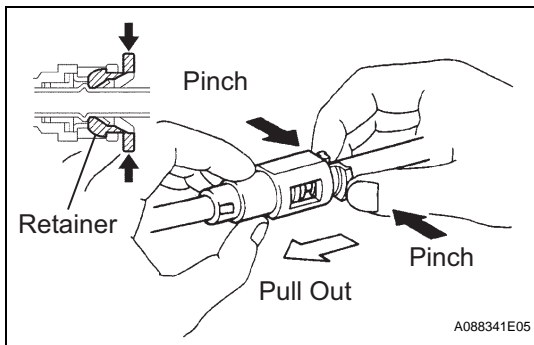

- (f) Take the following precautions when removing the fuel tube connector (Type B).
- (1) Check the fuel tube connector and pipe for dirt or mud before removing the fuel tube connector. If they are dirty, wipe them off with a shop rag.
  - (2) Pinch the retainer as illustrated, then pull out the fuel tube connector from the pipe.

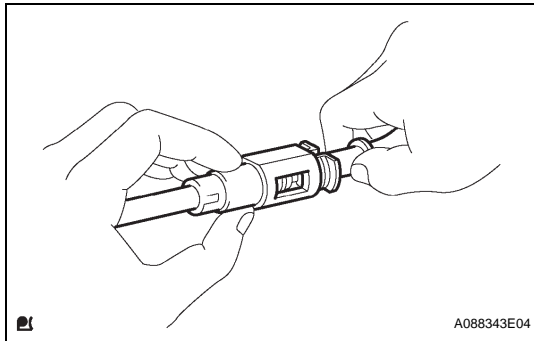

- (3) If the fuel connector and pipe are stuck, pinch the pipe, then push and pull the fuel tube connector to release and disconnect the fuel tube connector.

**NOTICE:**

**Do not use any tools.**

- (4) After removing the fuel tube, check the sealing surface of the pipe for dirt or mud. If it is dirty, wipe it off with a shop rag.

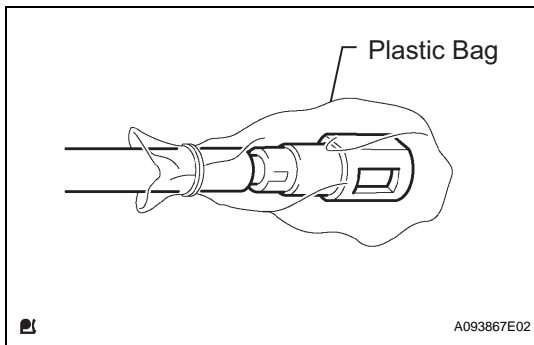

- (5) Cover the disconnected fuel tube connector and pipe with a plastic bag to prevent damage and intrusion of foreign objects.

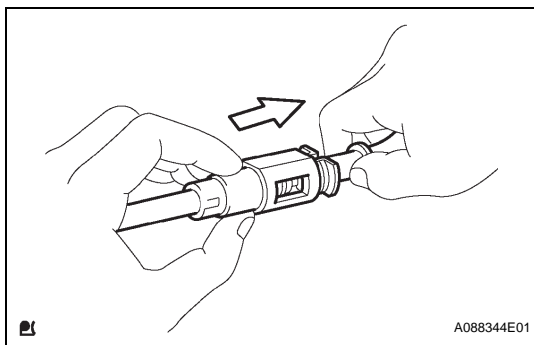

- (g) Take the following precautions when installing the fuel tube connector (Type B).

- (1) Align the fuel tube connector with the pipe, then push in the fuel tube connector until the retainer makes a "click" sound.

**HINT:**

If they are connected too tightly, apply a light coat of engine oil to the tip of the pipe, then install the fuel tube connector.

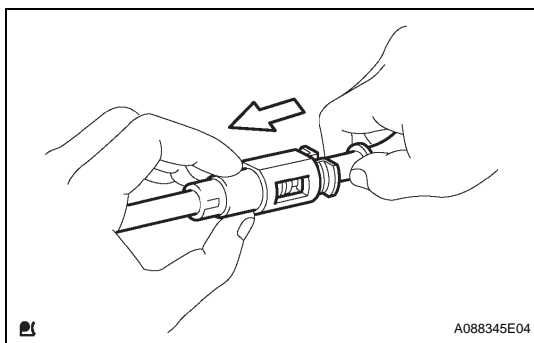

- (2) After connecting the fuel tube connector, check that the fuel tube connector and pipe are securely connected by pulling them.

**4. CHECK FOR FUEL LEAKS**

- (a) Check that there are no fuel leaks after doing maintenance on the fuel system (see page [FU-7](#)).

# PARTS LOCATION

POWER SOURCE CONTROL ECU

ECM

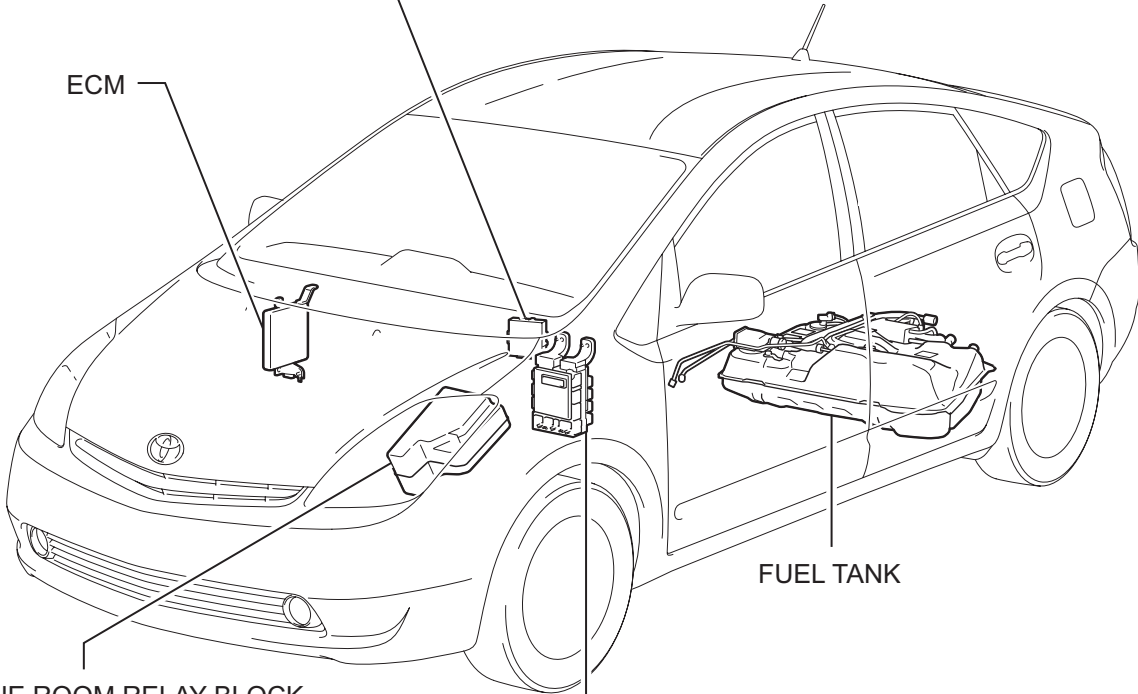

FUEL TANK

ENGINE ROOM RELAY BLOCK,  
JUNCTION BLOCK  
- INTEGRATION RELAY  
(UNIT B: IG2 RELAY)  
(UNIT C: C/OPN RELAY)  
- AM2 FUSE  
- P/I H-FUSE

DRIVER SIDE JUNCTION BLOCK  
- IGN FUSE

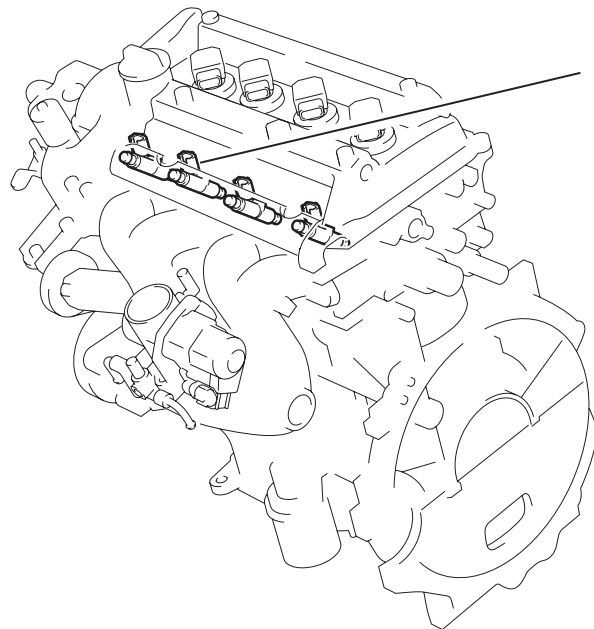

FUEL INJECTOR

FU

# SYSTEM DIAGRAM

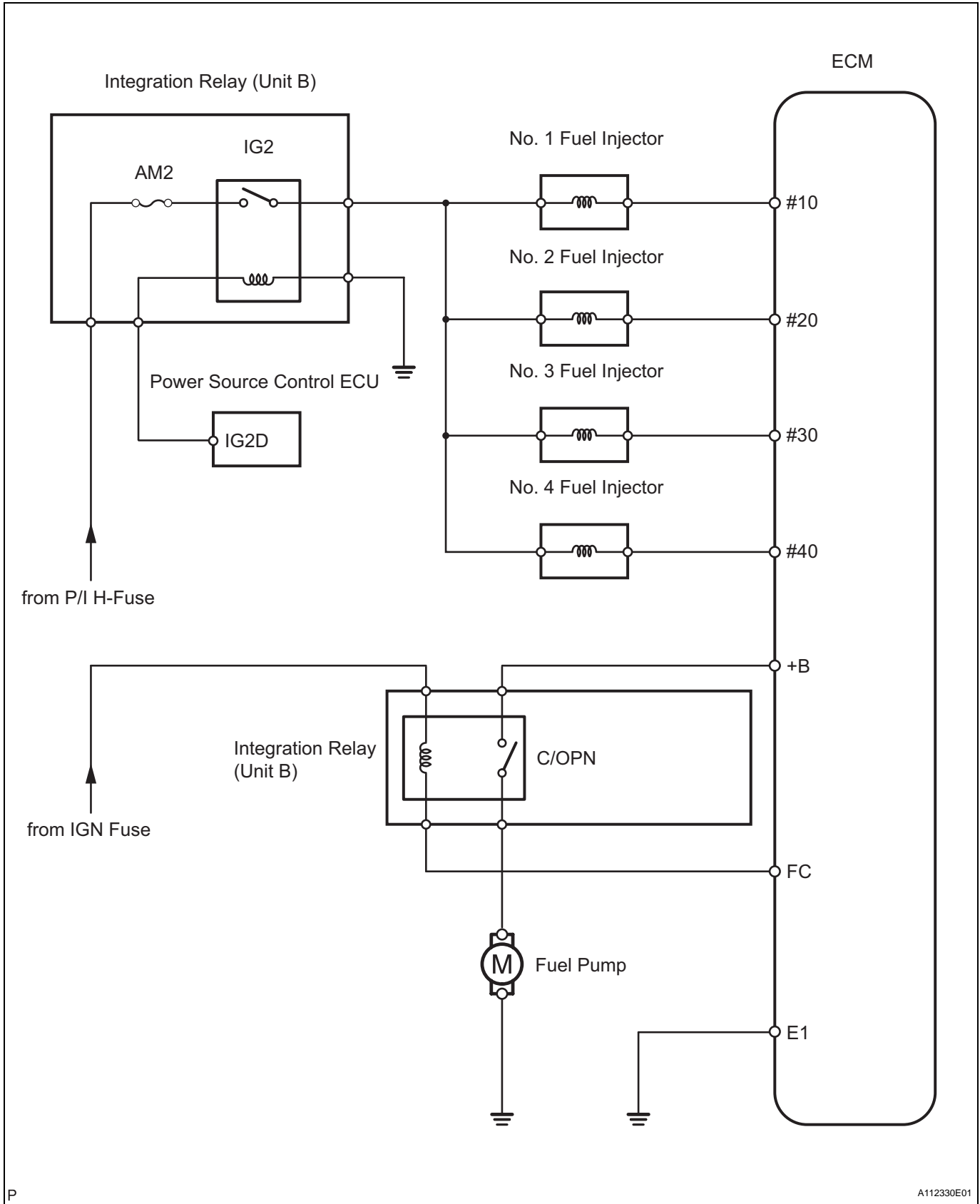

FU

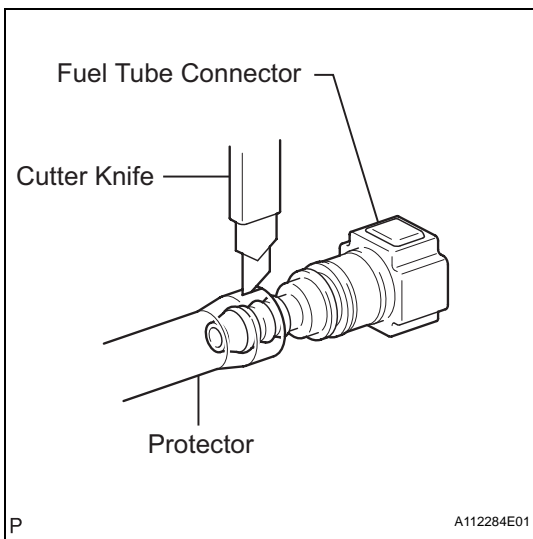

## ON-VEHICLE INSPECTION

### 1. CHECK FUEL PRESSURE

- (a) Prepare for the inspection.
  - (1) Prepare a new fuel tube.
 

**HINT:**  
Part No. 23901-21081
  - (2) Using a cutter knife, cut off the protector of the fuel tube as illustrated. Tear off the protector by hand, then remove the fuel tube connector.

**NOTICE:**

**If the protector is cut too deeply using the cutter, the O-ring of the fuel tube connector will be damaged.**

- (b) Discharge fuel system pressure (see page [FU-12](#)).
- (c) Using a voltmeter, measure the battery voltage.

**Standard voltage:**

**9.0 to 14 V**

- (d) Disconnect the cable from the negative (-) battery terminal.

**CAUTION:**

**Wait at least 90 seconds after disconnecting the cable from the negative (-) battery terminal to prevent airbag and seat belt pretensioner activation.**

- (e) Disconnect the fuel tube (see page [FU-14](#)).
- (f) Install SST and the fuel tube connector to the vehicle.
 

**SST 09268-41047 (95336-08070), 09268-45014 (09268-41200, 09268-41220, 09268-41250)**
- (g) Wipe off any spilt gasoline.
- (h) Connect the cable to the negative battery terminal.

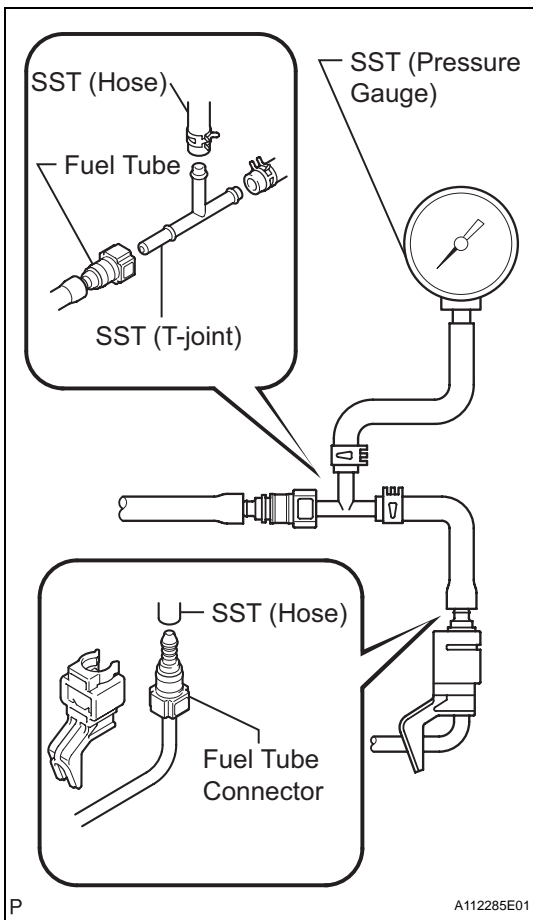

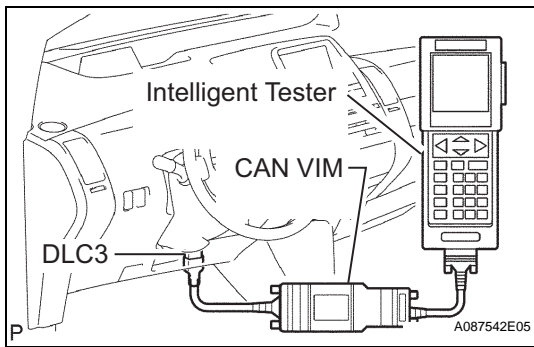

- (i) Connect the intelligent tester (with CAN VIM) to the DLC3.
- (j) Measure the fuel pressure.

**Standard:**

**304 to 343 kPa (3.1 to 3.5 kgf/cm<sup>2</sup>, 44 to 50 psi)**

- If the fuel pressure is greater than the standard value, replace the fuel tank.
  - If the fuel pressure is less than the standard value, check the connection of the fuel hose and fuel tank.
- (k) Disconnect the intelligent tester from the DLC3.
  - (l) Set the vehicle to inspection mode (see page [IN-34](#)).
  - (m) Start the engine.
  - (n) Measure the fuel pressure at idle.

**Standard:**

**304 to 343 kPa (3.1 to 3.5 kgf/cm<sup>2</sup>, 44 to 50 psi)**

- (o) Stop the engine.
- (p) After stopping the engine, check that the fuel pressure does not change for 5 minutes.

**Standard:**

**147 kPa (1.5 kgf/cm<sup>2</sup>, 21 psi) or more**

If the fuel pressure is not as specified, check the fuel tank or fuel injectors (see page [FU-15](#)).

- (q) After measuring the fuel pressure, disconnect the cable from the negative battery terminal. Remove SST and the fuel tube connector while taking care to prevent spilling gasoline.
- (r) Connect the fuel tube (see page [FU-18](#)).

**2. CHECK FUEL PUMP**

- (a) Connect the intelligent tester (with CAN VIM) to the DLC3.
- (b) Turn the power switch ON (IG).

**NOTICE:**

**Do not start the engine.**

- (c) Turn the intelligent tester ON.
- (d) Select the item: DIAGNOSIS / ENHANCED OBD II / ACTIVE TEST / FUEL PUMP / SPD.
- (e) Check the fuel pump operation while operating it with the intelligent tester.  
If the fuel pump does not operate, replace the fuel tank.

**3. CHECK FOR FUEL LEAKS**

- (a) Check that there are no leaks in the fuel system while fuel pressure is applied.

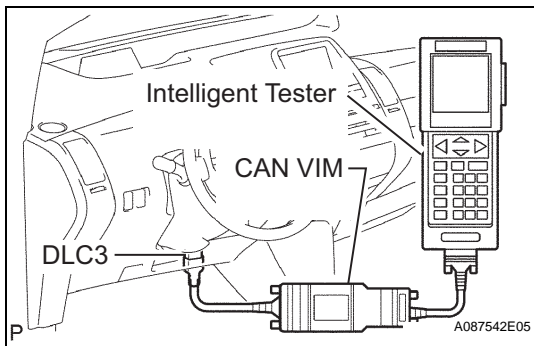



# FUEL INJECTOR COMPONENTS

FU

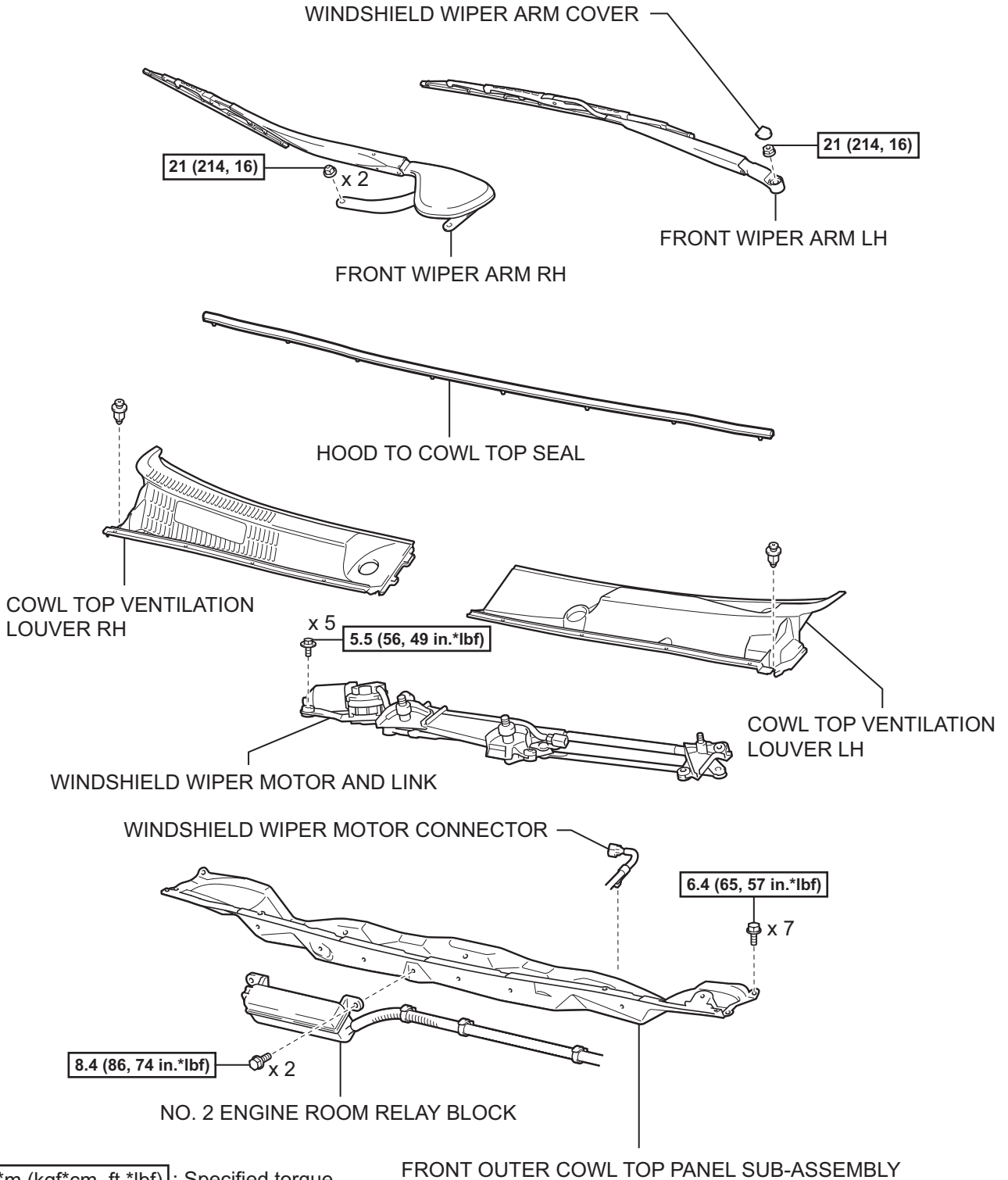

**N\*m (kgf\*cm, ft.\*lbf)** : Specified torque

FU

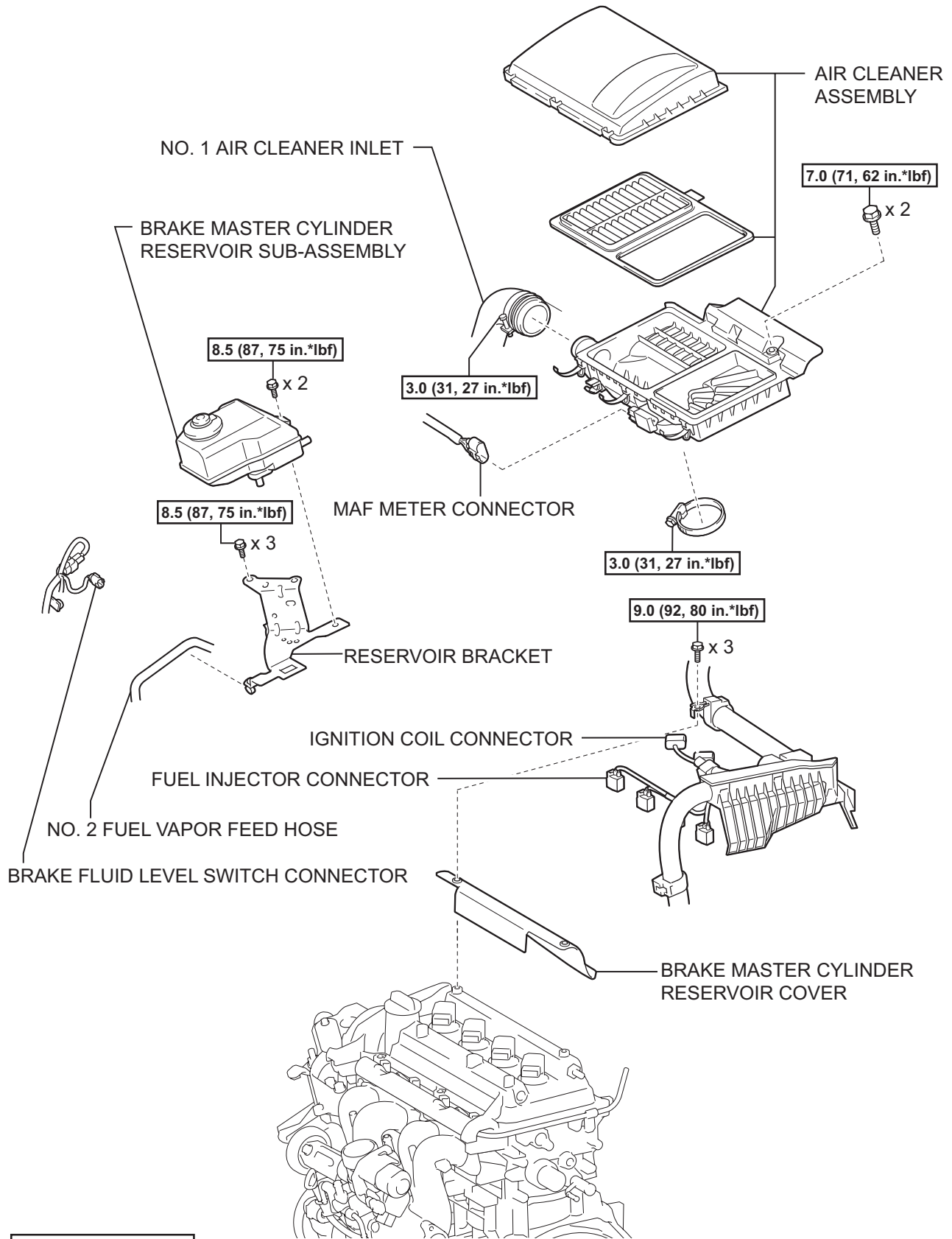

N\*m (kgf\*cm, ft.\*lbf) : Specified torque

● Non-reusable part

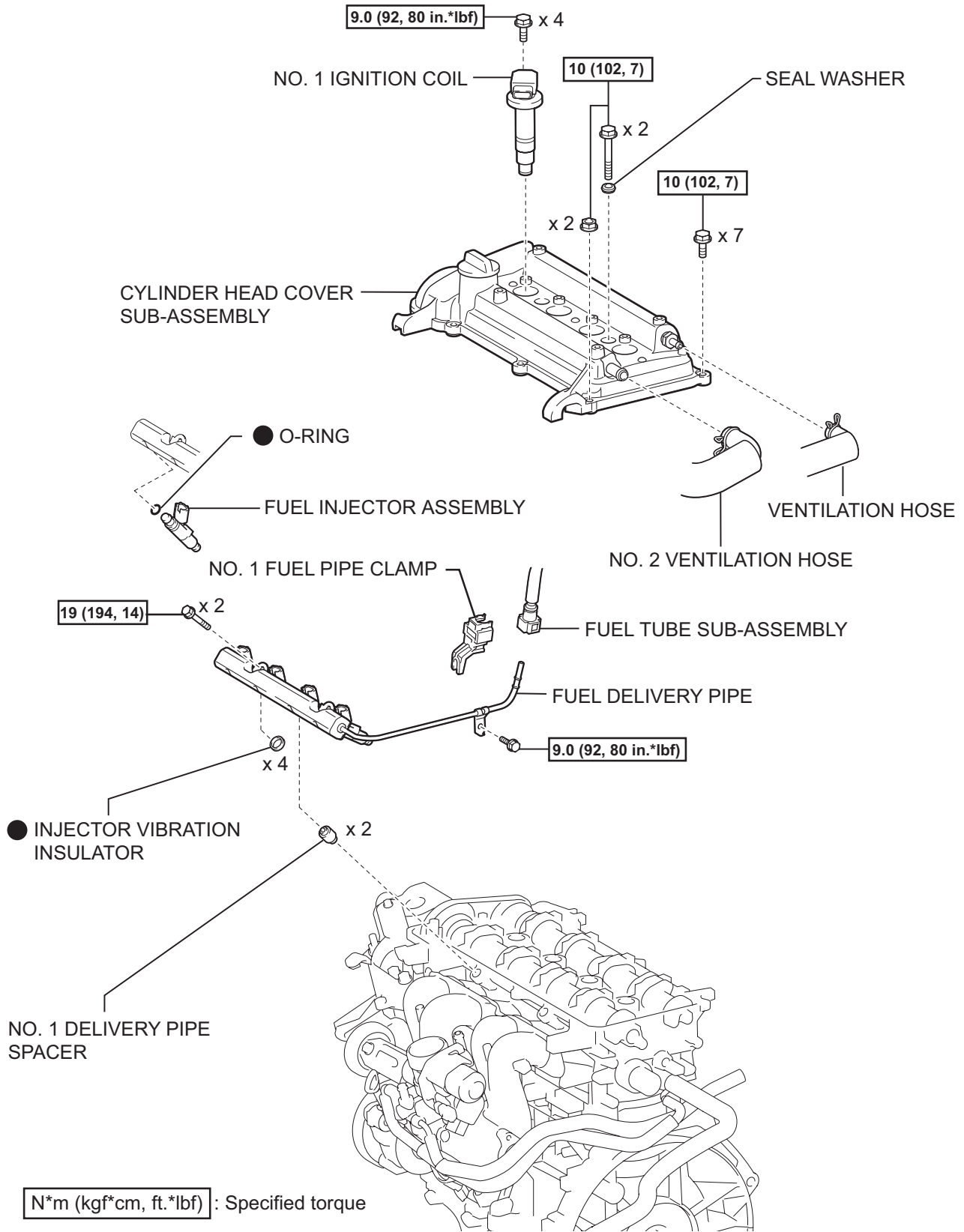

## REMOVAL

### 1. DISCHARGE FUEL SYSTEM PRESSURE

#### CAUTION:

- **DISCHARGE FUEL SYSTEM PRESSURE** procedures must be performed before disconnecting any part of the fuel system.
- After performing the **DISCHARGE FUEL SYSTEM PRESSURE** procedures, pressure will remain in the fuel line. When disconnecting the fuel line, place a cloth or equivalent over fittings to reduce the risk of fuel spray.

- (a) Remove the integration relay (unit C: C/OPN relay) from the engine room junction block.
- (b) Start the engine. After the engine has stopped, turn the power switch OFF.

#### HINT:

DTC P0171 (system too lean) may be set.

- (c) Check that the engine does not start.
- (d) Remove the fuel tank cap, and let the air out of the fuel tank.
- (e) Disconnect the cable from the negative (-) battery terminal.

#### CAUTION:

**Wait at least 90 seconds after disconnecting the cable from the negative (-) battery terminal to prevent airbag and seat belt pretensioner activation.**

- (f) Install the integration relay (unit C: C/OPN relay) to the engine room junction block.

### 2. REMOVE WINDSHIELD WIPER MOTOR AND LINK

- (a) Remove the windshield wiper motor and link (see page [WW-13](#)).

### 3. REMOVE FRONT OUTER COWL TOP PANEL SUB-ASSEMBLY

- (a) Remove the 2 bolts and disconnect the No. 2 engine room relay block.
- (b) Remove the 4 wire harness clamps.

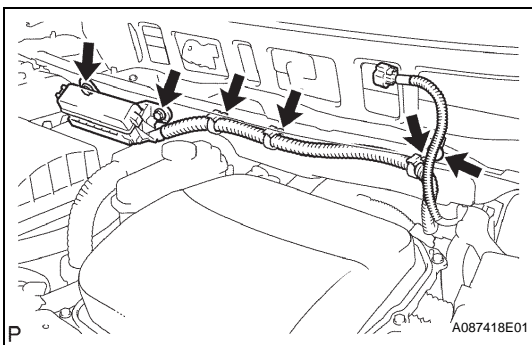

- (c) Remove the 7 bolts and panel.

### 4. REMOVE AIR CLEANER ASSEMBLY (See page [ES-450](#))

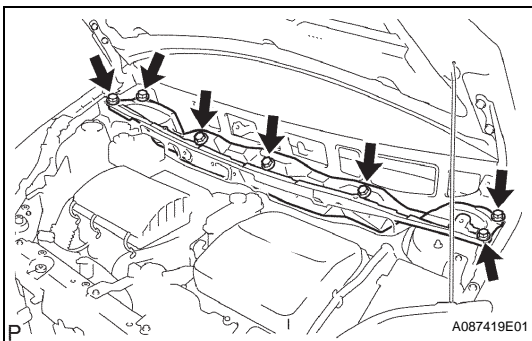

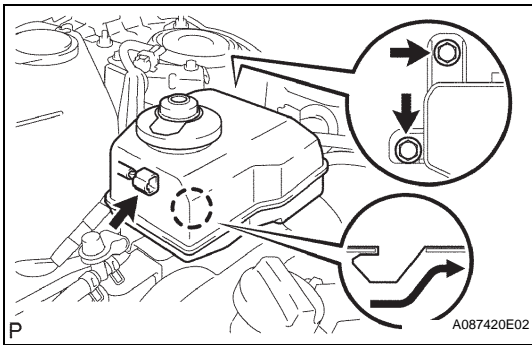

#### 5. REMOVE BRAKE MASTER CYLINDER RESERVOIR SUB-ASSEMBLY

- Disconnect the brake fluid level switch connector.
- Remove the 2 bolts.
- Disconnect the claw fitting, then remove the brake master cylinder reservoir.

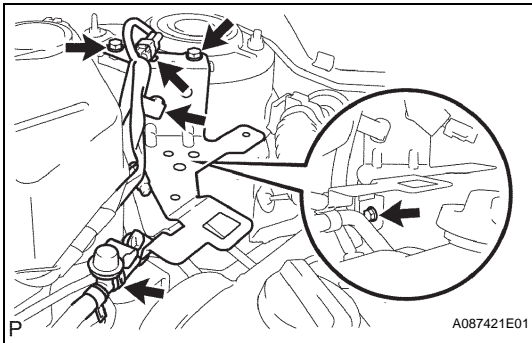

#### 6. REMOVE RESERVOIR BRACKET

- Remove the No. 2 fuel vapor feed hose from the hose clamp.
- Remove the connector clamp.
- Remove the wire harness clamp.
- Remove the 3 bolts and reservoir bracket.

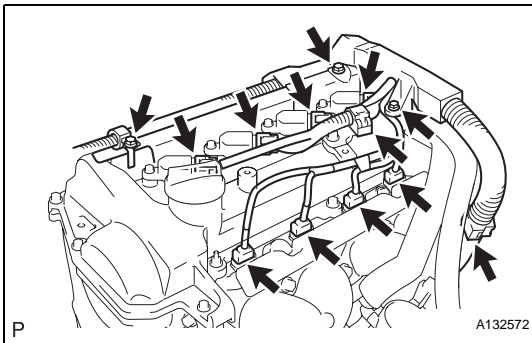

#### 7. REMOVE CYLINDER HEAD COVER SUB-ASSEMBLY

- Remove the 2 wire harness clamps.
- Disconnect the 4 fuel injector connectors.
- Disconnect the 4 ignition coil connectors.
- Remove the 3 bolts, then remove the engine wire and brake master cylinder reservoir cover.

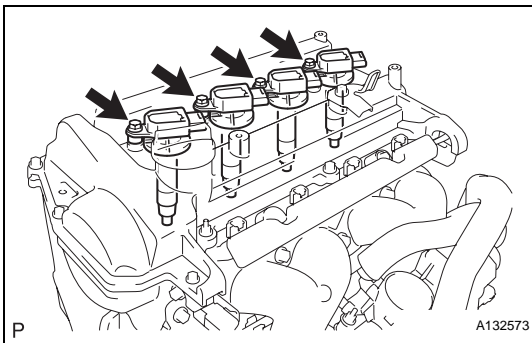

- Remove the 4 bolts and 4 ignition coils.

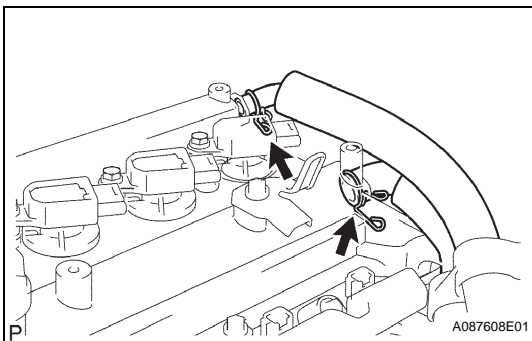

- Disconnect the ventilation hose from the ventilation valve.
- Disconnect the No. 2 ventilation hose from the cylinder head cover.

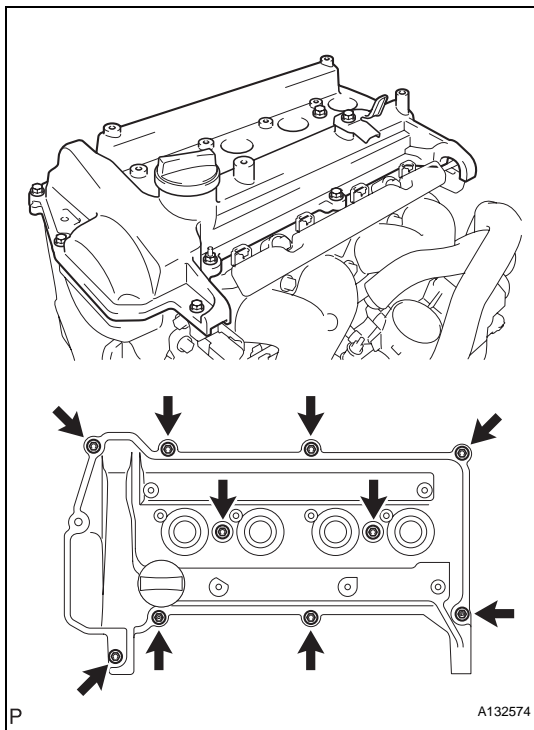

- (h) Remove the 9 bolts, 2 seal washers, 2 nuts and cylinder head cover.

FU

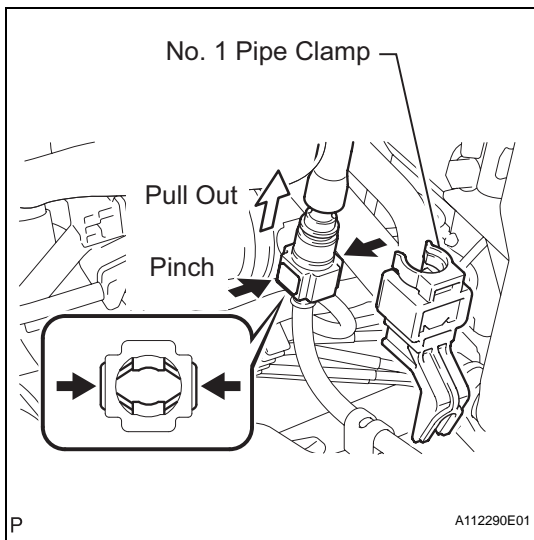

## 8. REMOVE FUEL DELIVERY PIPE

- (a) Disconnect the fuel tube from the fuel delivery pipe.  
 (1) Remove the No. 1 fuel pipe clamp.

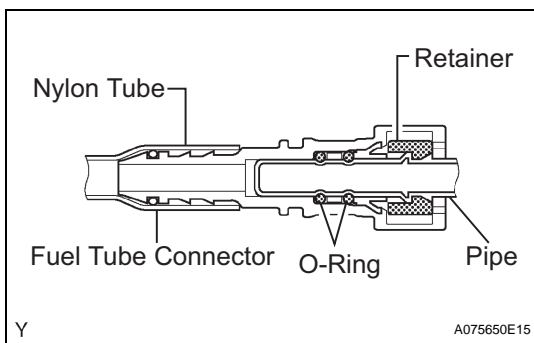

- (2) Pinch the retainer of the fuel tube connector, and then pull out the fuel tube connector to disconnect the fuel tube from the fuel delivery pipe.

### NOTICE:

- Remove dirt or foreign objects on the fuel tube connector before this procedure.
- Do not allow any scratches or foreign objects on the parts when disconnecting them, as the fuel tube connector has the O-ring that seals the pipe.
- Perform this work by hand. Do not use any tools.
- Do not forcibly bend, twist or turn the nylon tube.

- Protect the connecting part by covering it with a plastic bag after disconnecting the fuel tube.
- If the fuel tube connector and pipe are stuck, push and pull them to release them.

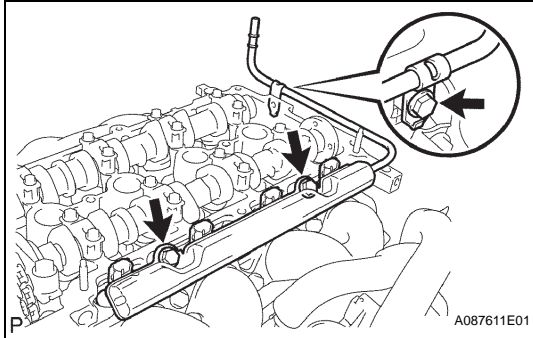

- (b) Remove the 3 bolts and fuel delivery pipe together with the 4 fuel injectors.

**NOTICE:**

Do not drop the fuel injectors when removing the fuel delivery pipe.

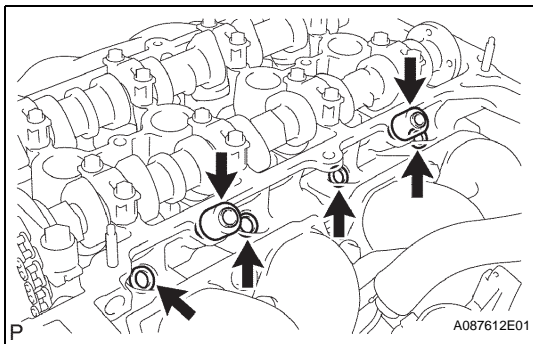

- (c) Remove the 2 No. 1 delivery pipe spacers from the cylinder head.  
 (d) Remove the 4 insulators from the cylinder head.

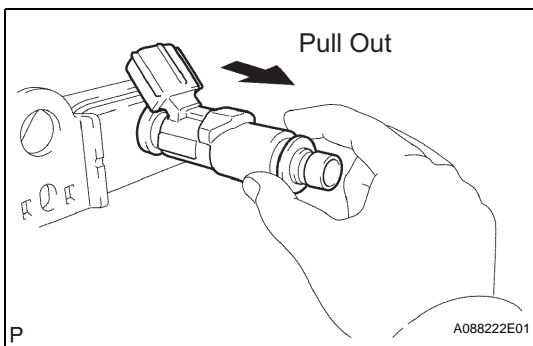
**9. REMOVE FUEL INJECTOR ASSEMBLY**

- (a) Pull out the 4 fuel injectors from the fuel delivery pipe.

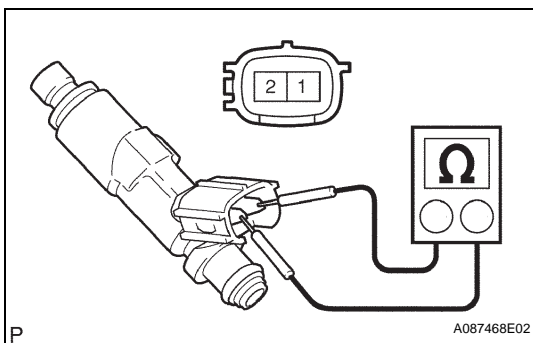
**INSPECTION****1. INSPECT FUEL INJECTOR ASSEMBLY**

- (a) Measure the resistance between the terminals.

**Standard resistance:**

**13.45 to 14.15  $\Omega$  at 21°C (68°F)**

If the resistance is not as specified, replace the fuel injector assembly.

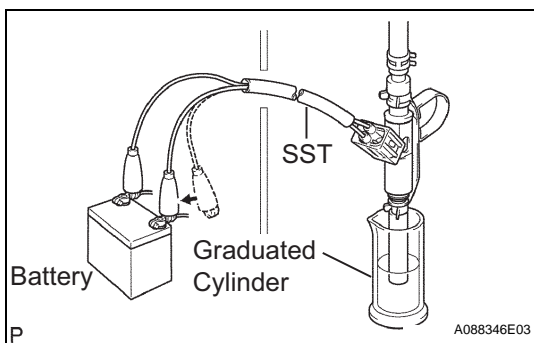
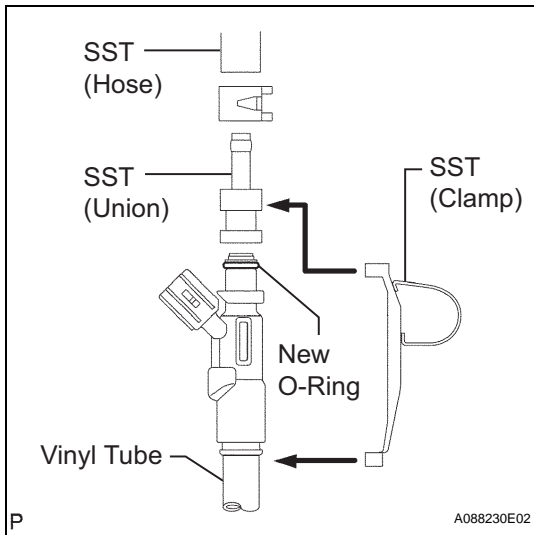
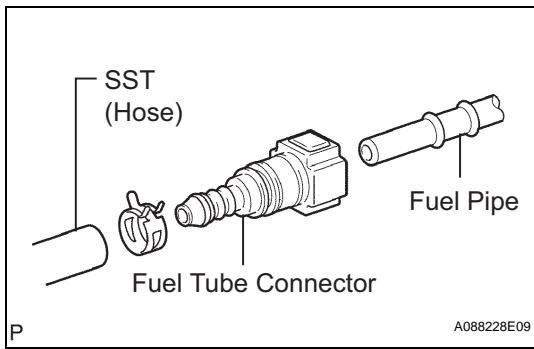
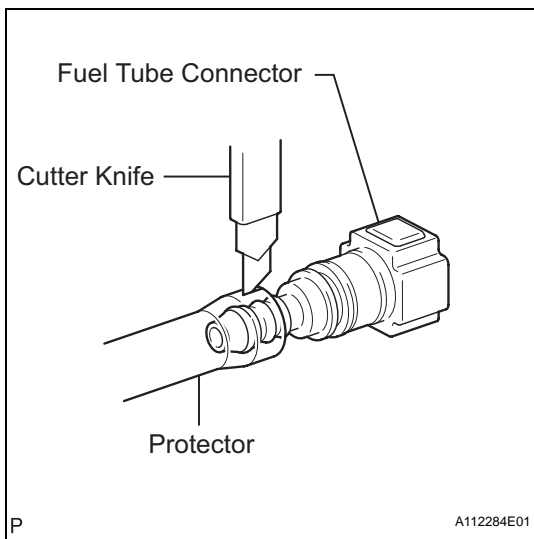

(b) Inspect the injection volume.

**CAUTION:**

**Perform the test in a well-ventilated area away from flames.**

**NOTICE:**

**Carefully handle the fuel tube connector.**

(1) Prepare a new fuel tube.

**HINT:**

Part No. 23901-21081

(2) Using a cutter knife, cut off the protector of the fuel tube as illustrated. Tear off the protector by hand, then remove the fuel tube connector.

**NOTICE:**

**If the protector is cut too deeply using the cutter, the O-ring of the fuel tube connector will be damaged.**

(3) Install SST to the fuel tube connector, and connect the fuel tube connector to the fuel pipe (the vehicle side).

**SST 09268-41047 (95336-08070)**

(4) Install a new O-ring to the fuel injector.

(5) Install SST and the vinyl tube to the fuel injector.

**SST 09268-41047 (09268-41110, 09268-41300)**

(6) Set the fuel injector to a graduated cylinder.

(7) Actuate the fuel pump (see page [FU-7](#)).

(8) Install SST to the fuel injector.

**SST 09842-30080**



- (9) Connect SST to the battery, then measure the injection volume for 15 seconds. Perform the inspection 2 or 3 times, then calculate the average.

#### Standard injection volume

Injection Volume	Difference between each fuel injector
36 to 46 cm <sup>3</sup> (2.1 to 2.8 cu in.)	10 cm <sup>3</sup> (0.6 cu in.) or less

#### NOTICE:

**Always turn the voltage on and off on the battery side, not the fuel injector side.**

If the injection volume is not as specified, replace the fuel injector assembly.

- (c) Inspect the leakage.
- (1) In the condition that the injection volume was inspected, remove SST from the battery. Inspect the fuel leakage from the fuel injector.

#### Standard fuel drop:

**1 drop or less per 12 minutes**

If the fuel leakage is not as specified, replace the fuel injector assembly.

FU

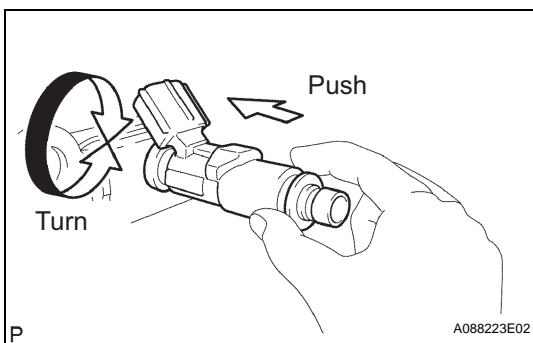
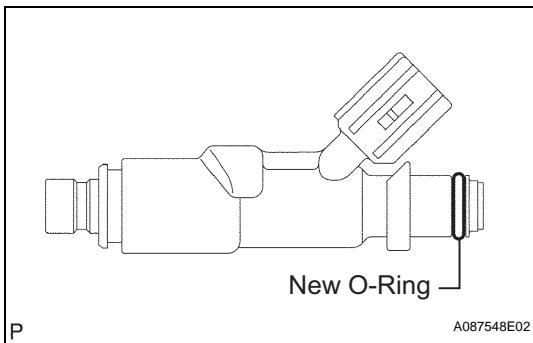
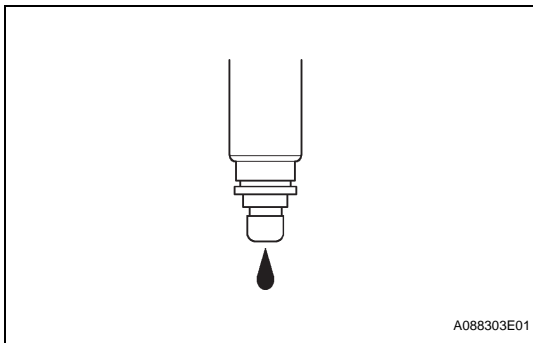

## INSTALLATION

### 1. INSTALL FUEL INJECTOR ASSEMBLY

- (a) Apply a light coat of spindle oil or gasoline to a new O-ring, then install it to each fuel injector.
- (b) Apply a light coat of spindle oil or gasoline to the surface of the fuel delivery pipe which contacts the O-ring of the fuel injector.
- (c) Apply a light coat of spindle oil or gasoline to the O-ring again, and install the fuel injector by turning it right and left while pushing it onto the fuel delivery pipe.
- NOTICE:**  
**Be careful that the O-ring is not cracked or jammed when installing it.**
- (d) Check that the fuel injector rotates smoothly. If the fuel injector does not rotate, replace the O-ring.

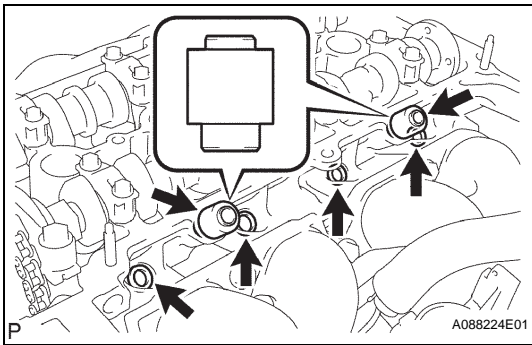

## 2. INSTALL FUEL DELIVERY PIPE

- (a) Install 4 new insulators to the cylinder head.
- (b) Install the 2 No. 1 delivery pipe spacers to the cylinder head.

**NOTICE:**

**Be careful of the installation direction of the delivery pipe spacer.**

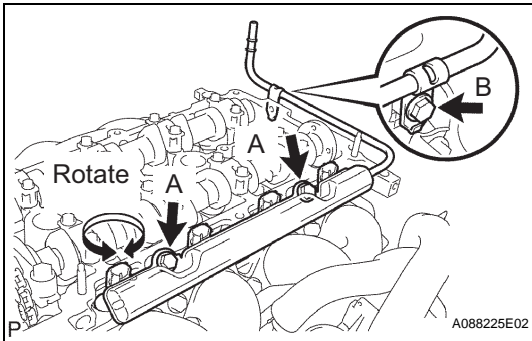

- (c) Install the fuel delivery pipe together with the 4 fuel injectors, and then temporarily tighten the 3 bolts.

**NOTICE:**

**Do not drop the fuel injectors when installing the fuel delivery pipe.**

- (d) Check that the fuel injectors rotate smoothly. If the fuel injectors do not rotate, replace the O-ring.
- (e) Retighten the 3 bolts to the specified torque.

**Torque: 19 N\*m (194 kgf\*cm, 14 ft.\*lbf) for bolt A  
9.0 N\*m (92 kgf\*cm, 80 in.\*lbf) for bolt B**

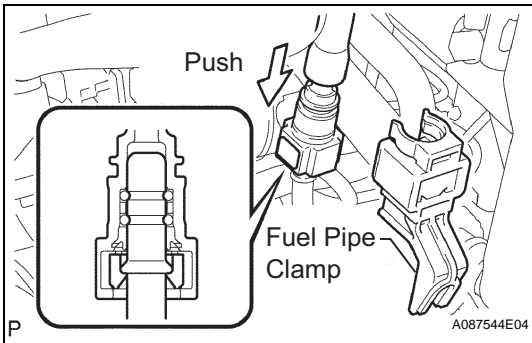

- (f) Connect the fuel tube to the fuel delivery pipe.
  - (1) Align the fuel tube connector with the pipe, then push in the fuel tube connector until the retainer makes a "click" sound to connect the fuel tube to the fuel delivery pipe.

**NOTICE:**

- Check that there are no scratches or foreign objects around the connected part of the fuel tube connector and pipe before this work.
- After connecting the fuel tube, check that the fuel tube connector and pipe are securely connected by pulling them.

- (2) Install the No. 1 fuel pipe clamp.

## 3. INSTALL CYLINDER HEAD COVER SUB-ASSEMBLY (See page EM-39)

## 4. INSTALL RESERVOIR BRACKET

- (a) Temporarily install the reservoir bracket with the bolt labeled 1 in the illustration.
- (b) Tighten the 3 bolts to the specified torque in the sequence shown in the illustration.

**Torque: 8.5 N\*m (87 kgf\*cm, 75 in.\*lbf)**

- (c) Install the connector clamp.
- (d) Install the wire harness clamp.
- (e) Install the No. 2 fuel vapor feed hose to the hose clamp.

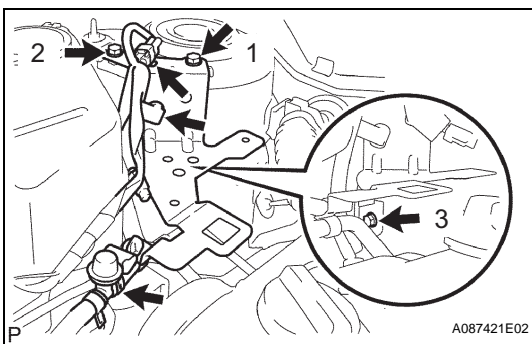

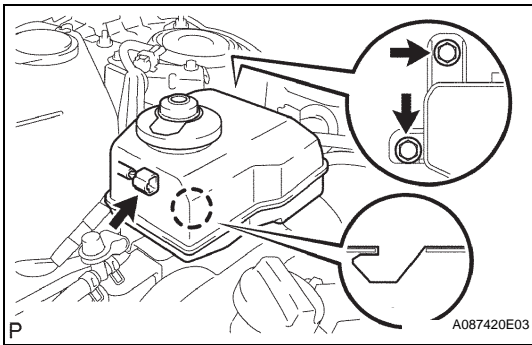

5. **INSTALL BRAKE MASTER CYLINDER RESERVOIR**
  - (a) Install the reservoir with the 2 bolts.  
**Torque: 8.5 N\*m (87 kgf\*cm, 75 in.\*lbf)**
  - (b) Connect the switch connector.
6. **INSTALL AIR CLEANER ASSEMBLY** (See page [ES-453](#))

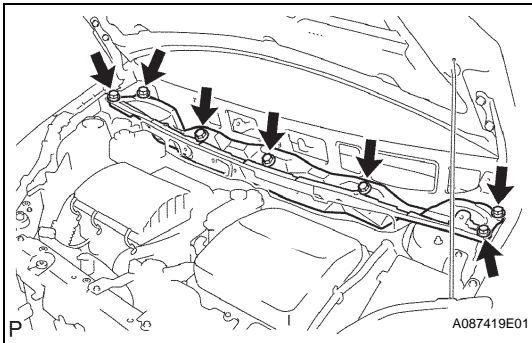

7. **INSTALL FRONT OUTER COWL TOP PANEL SUB-ASSEMBLY**
  - (a) Install the panel with the 7 bolts.  
**Torque: 6.4 N\*m (65 kgf\*cm, 57 in.\*lbf)**

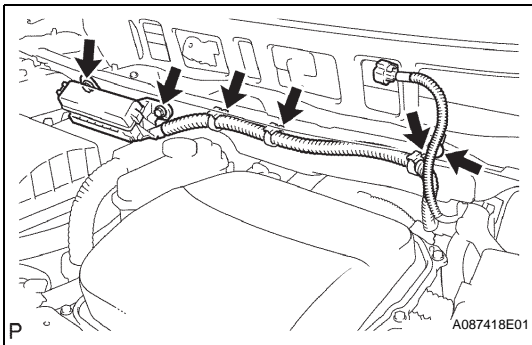

- (b) Connect the 4 wire harness clamps.
  - (c) Install the No. 2 engine room relay block with the 2 bolts.  
**Torque: 8.4 N\*m (86 kgf\*cm, 74 in.\*lbf)**
8. **INSTALL WINDSHIELD WIPER MOTOR AND LINK**
  - (a) Install the windshield wiper motor and link (see page [WW-15](#)).
9. **CONNECT CABLE TO NEGATIVE BATTERY TERMINAL**
10. **CHECK FOR FUEL LEAKS** (See page [FU-8](#))
11. **PERFORM INITIALIZATION**
  - (a) Perform initialization (see page [IN-32](#)).  
**NOTICE:**  
Certain systems need to be initialized after disconnecting and reconnecting the cable from the negative (-) battery terminal.

# FUEL TANK COMPONENTS

FU

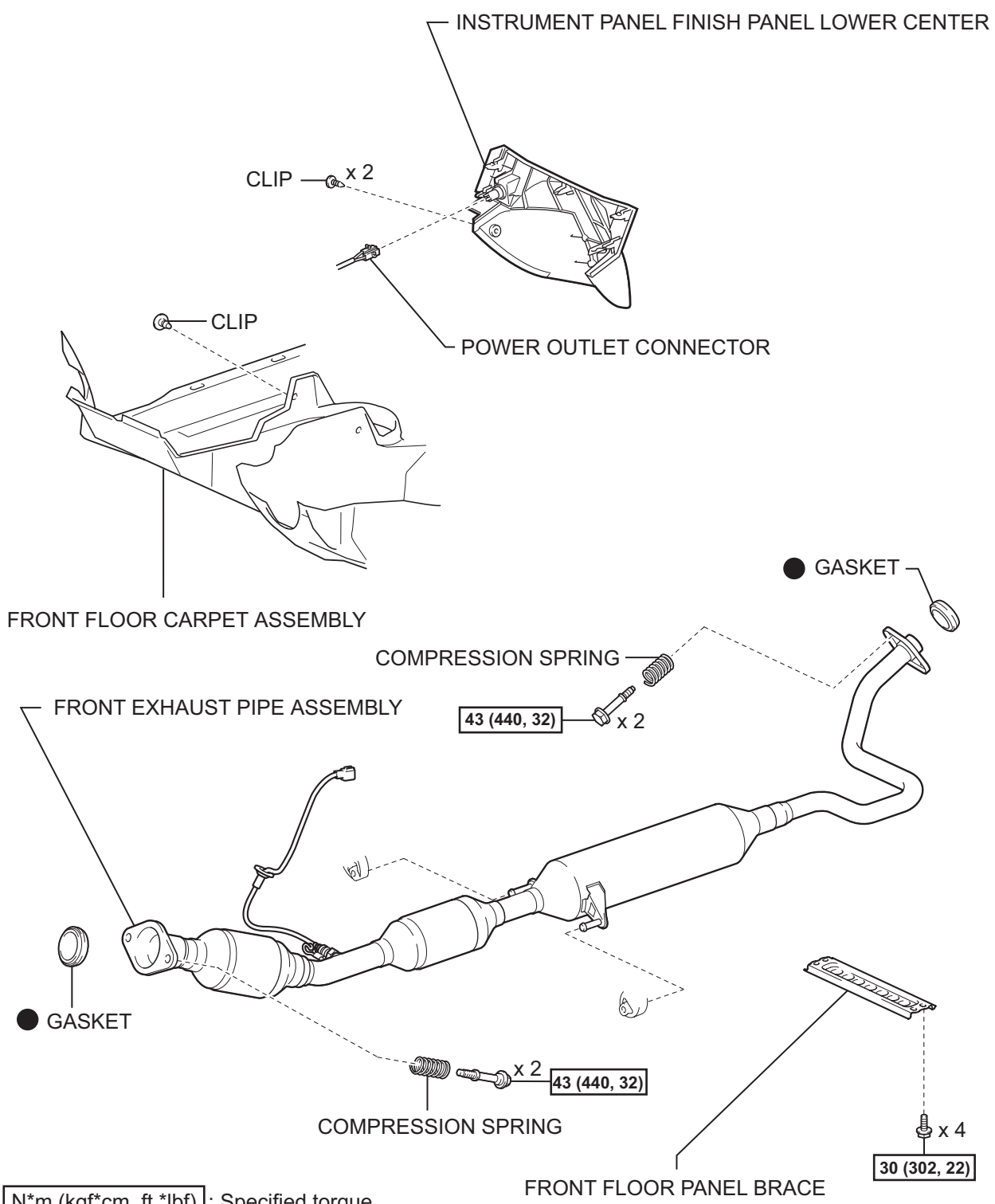

**N\*m (kgf\*cm, ft.\*lbf)** : Specified torque

● Non-reusable part

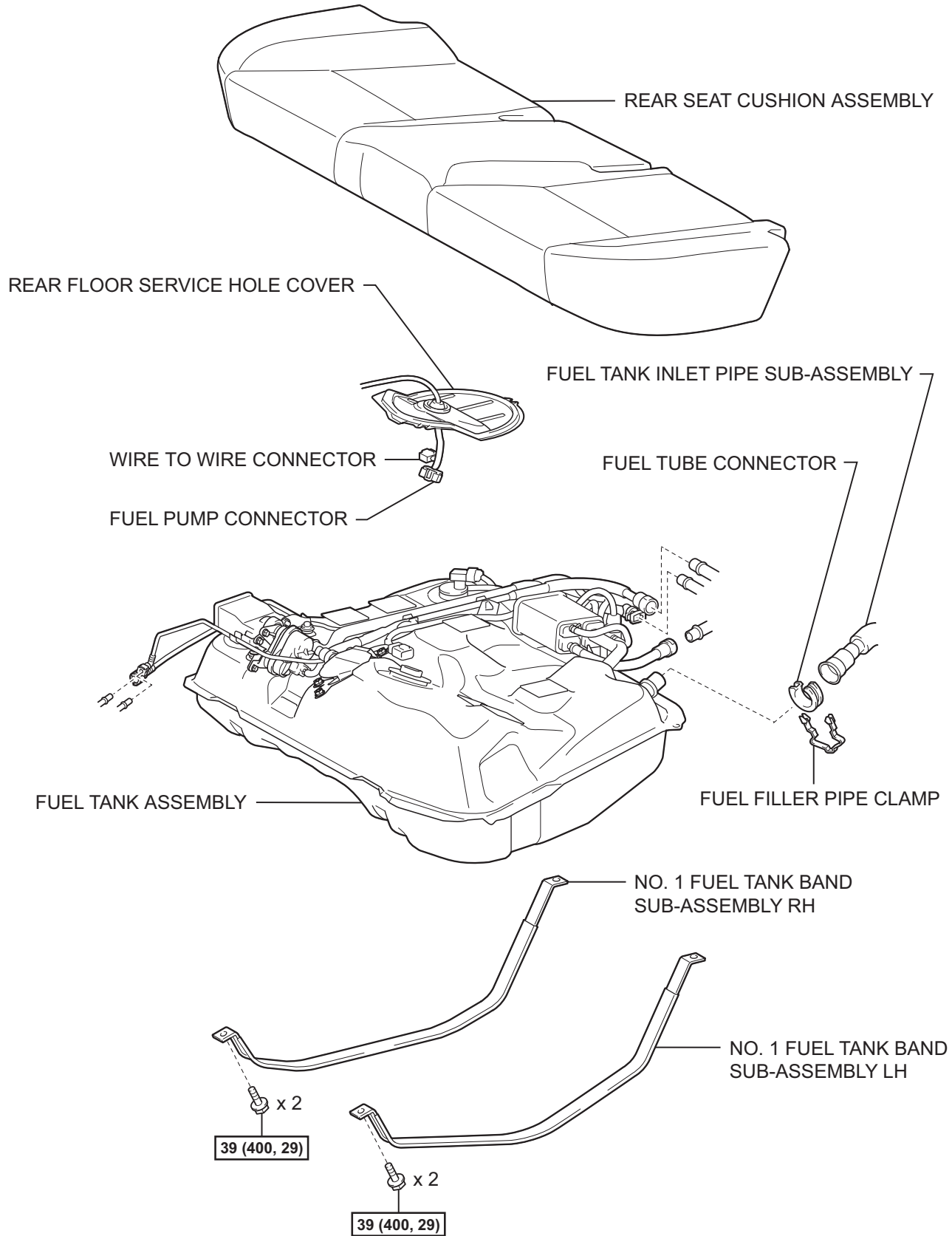

**N\*m (kgf\*cm, ft.\*lbf)** : Specified torque

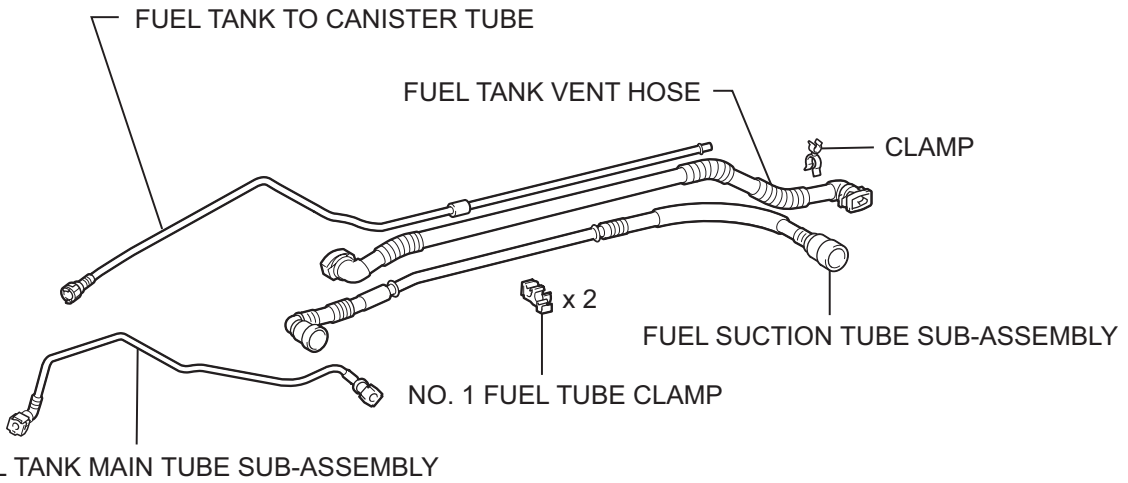

FU

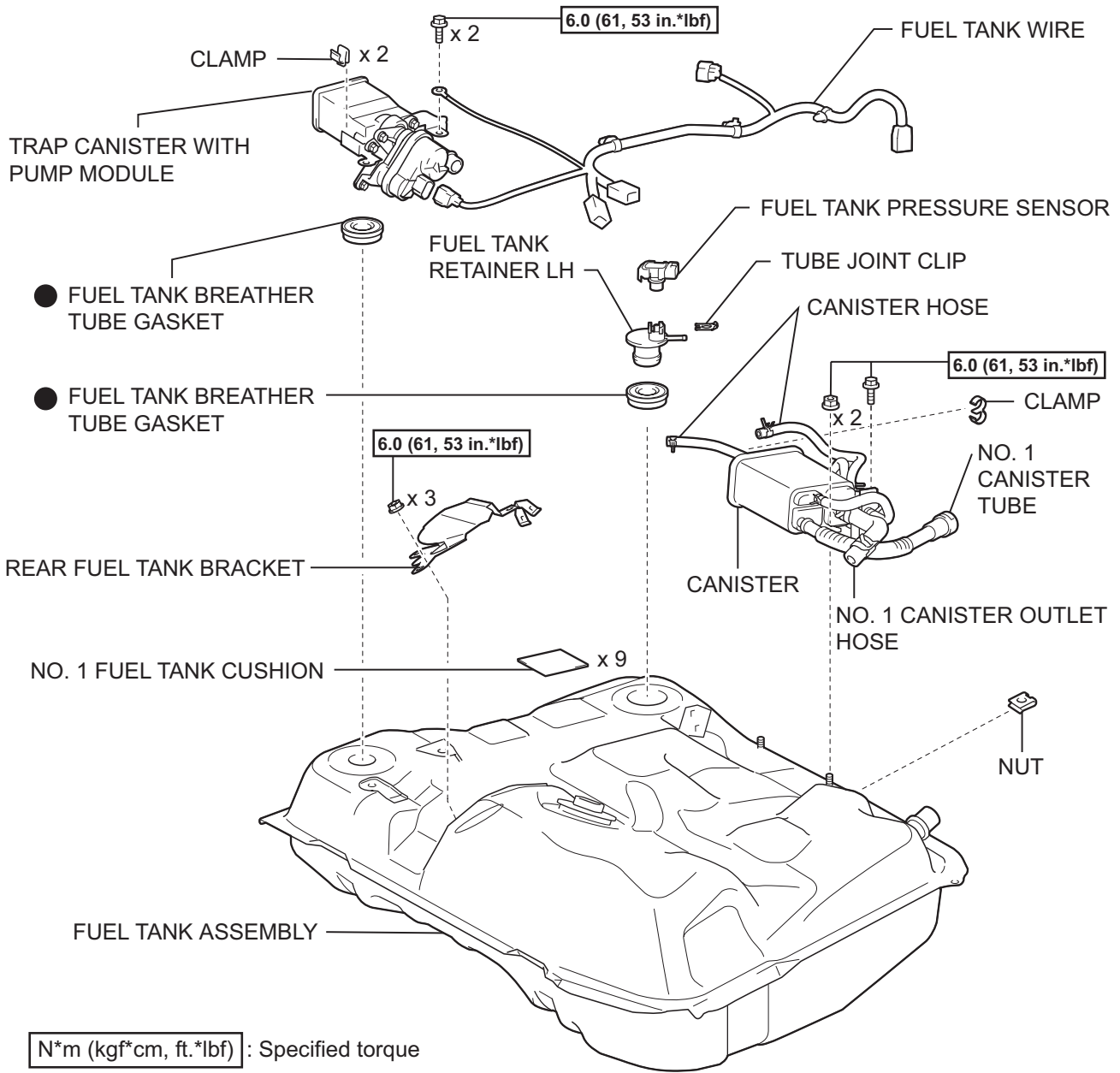

N\*m (kgf\*cm, ft.\*lbf) : Specified torque

● Non-reusable part

## REMOVAL

1. DISCHARGE FUEL SYSTEM PRESSURE (See page [FU-12](#))
2. REMOVE INSTRUMENT PANEL FINISH PANEL LOWER CENTER (See page [IP-18](#))
3. REMOVE FRONT FLOOR PANEL BRACE (See page [EX-2](#))
4. REMOVE FRONT EXHAUST PIPE ASSEMBLY (See page [EX-2](#))
5. REMOVE REAR SEAT CUSHION ASSEMBLY (See page [SE-15](#))
6. REMOVE REAR FLOOR SERVICE HOLE COVER
  - (a) Remove the butyl tape and rear floor service hole cover.
  - (b) Disconnect the fuel pump connector.
  - (c) Disconnect the wire to wire connector.

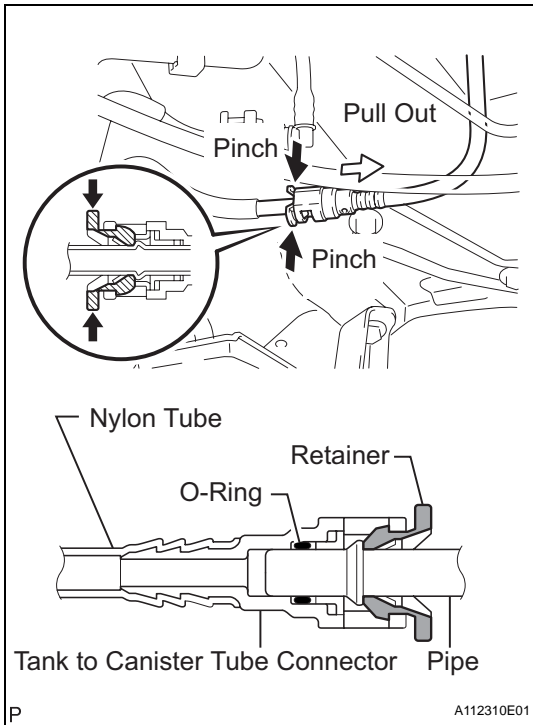
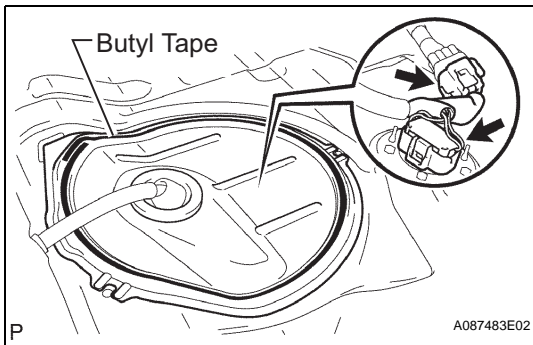

### 7. REMOVE FUEL TANK ASSEMBLY

- (a) Disconnect the fuel tank to canister tube.
  - (1) Pinch the retainer of the fuel tube connector, then pull out the fuel tube connector to disconnect the fuel tank to canister tube from the pipe.

#### NOTICE:

- Remove dirt or foreign objects on the fuel tube connector before this procedure.
- Do not allow any scratches or foreign objects on the parts when disconnecting them as the fuel tube connector has the O-ring that seals the pipe.
- Perform this work by hand. Do not use any tools.
- Do not forcibly bend, twist or turn the nylon tube.
- Protect the connecting part by covering it with a plastic bag after disconnecting the fuel tank to canister tube.
- If the fuel tube connector and pipe are stuck, push and pull them to release them.

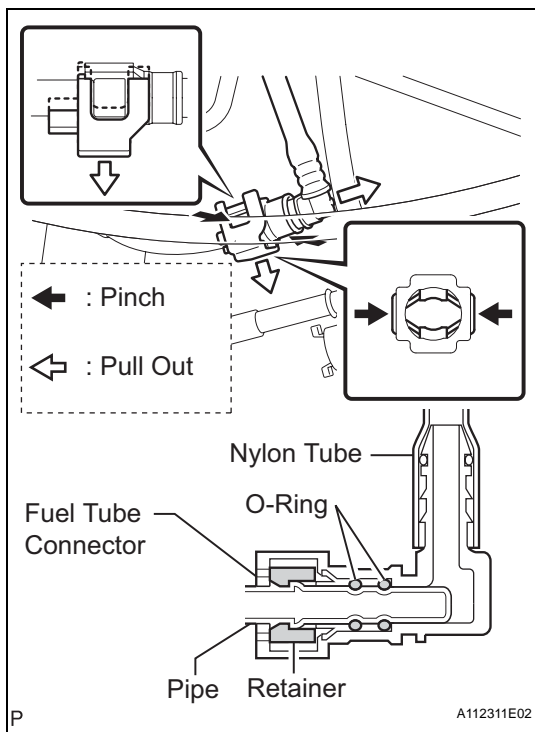

- (b) Disconnect the No. 2 fuel tank main tube.
- (1) Remove the checker of the fuel tube connector from the pipe.
  - (2) Pinch the retainer of the fuel tube connector, and then pull out the fuel tube connector to disconnect the No. 2 fuel tank main tube from the pipe.

**NOTICE:**

- Remove dirt or foreign objects on the fuel tube connector before this procedure.
- Do not allow any scratches or foreign objects on the parts when disconnecting them as the fuel tube connector has the O-ring that seals the pipe.
- Perform this work by hand. Do not use any tools.
- Do not forcibly bend, twist or turn the nylon tube.
- Protect the connecting part by covering it with a plastic bag after disconnecting the No. 2 fuel tank main tube.
- If the fuel tube connector and pipe are stuck, push and pull them to release them.

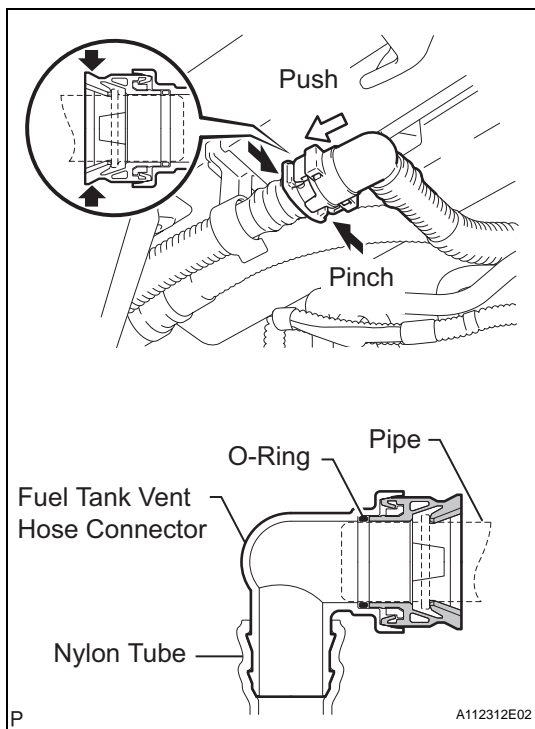

- (c) Disconnect the fuel tank vent hose.
- (1) Pinch the retainer and pull out the fuel tank vent hose connector with the fuel tank vent hose connector pushed to the pipe side to disconnect the fuel tank vent hose from the canister filter.

**NOTICE:**

- Remove dirt or foreign objects on the fuel tank vent hose connector before this procedure.
- Do not allow any scratches or foreign objects on the parts when disconnecting them as the fuel tank vent hose connector has the O-ring that seals the pipe.
- Perform this work by hand. Do not use any tools.
- Do not forcibly bend, twist or turn the nylon tube.
- Protect the connecting part by covering it with a plastic bag after disconnecting the fuel tank vent hose.
- If the fuel tank vent hose connector and pipe are stuck, push and pull them to release them.



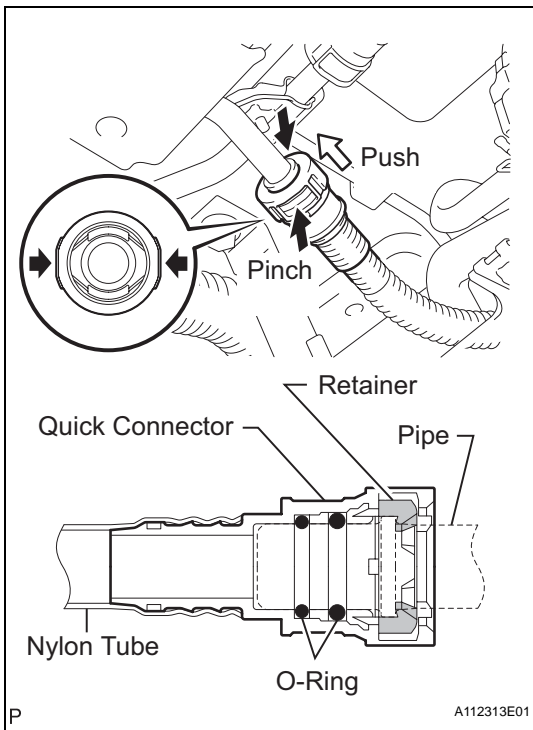

- (d) Disconnect the fuel suction tube.
- (1) Pinch the retainer and pull out the suction tube connector with the suction tube connector pushed to the pipe side to disconnect the fuel suction tube from the fuel tank to filler pipe.

**NOTICE:**

- Remove dirt or foreign objects on the quick connector before this procedure.
- Do not allow any scratches or foreign objects on the parts when disconnecting them as the fuel suction tube connector has the O-ring that seals the pipe.
- Perform this work by hand. Do not use any tools.
- Do not forcibly bend, twist or turn the nylon tube.
- Protect the connecting part by covering it with a plastic bag after disconnecting the fuel suction tube.
- If the fuel suction tube connector and pipe are stuck, push and pull them to release them.

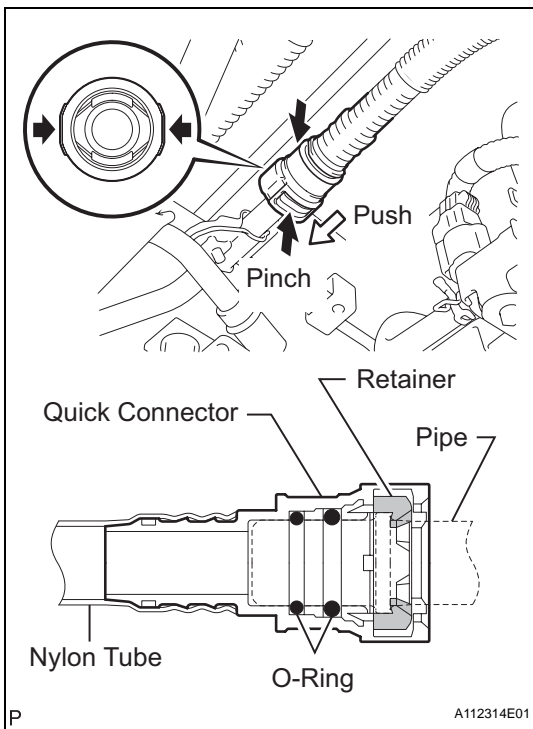

- (e) Disconnect the No. 1 canister tube.
- (1) Pinch the retainer and pull out the No. 1 canister tube connector with the No. 1 canister tube connector pushed to the pipe side to disconnect the No. 1 canister tube from the fuel tank to filler pipe.

**NOTICE:**

- Remove dirt or foreign objects on the quick connector before this procedure.
- Do not allow any scratches or foreign objects on the parts when disconnecting them as the No. 1 canister tube connector has the O-ring that seals the pipe.
- Perform this work by hand. Do not use any tools.
- Do not forcibly bend, twist or turn the nylon tube.
- Protect the connecting part by covering it with a plastic bag after disconnecting the tank to canister tube.
- If the No. 1 canister tube connector and pipe are stuck, push and pull them to release them.

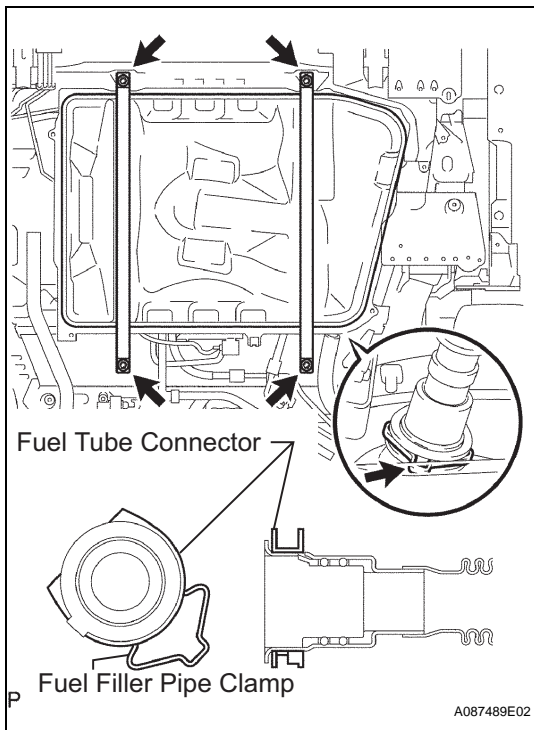

- (f) Set a transmission jack to the fuel tank.
- (g) Remove the fuel filler pipe clamp and fuel tube connector from the fuel tank inlet pipe.
- (h) Remove the 4 bolts and No. 1 fuel tank band RH and LH.
- (i) Operate the transmission jack, and then disconnect the fuel tank inlet pipe.
- (j) Operate the transmission jack, and then remove the fuel tank.

FU

#### 8. REMOVE NO. 2 FUEL TANK MAIN TUBE SUB-ASSEMBLY

- (a) Remove the 3 nuts and rear fuel tank bracket.
- (b) Disconnect the wire to wire connector from the rear fuel tank bracket.

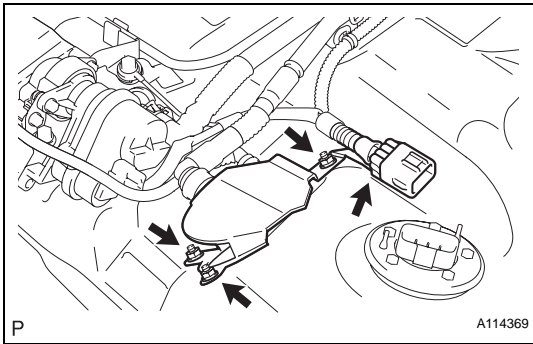

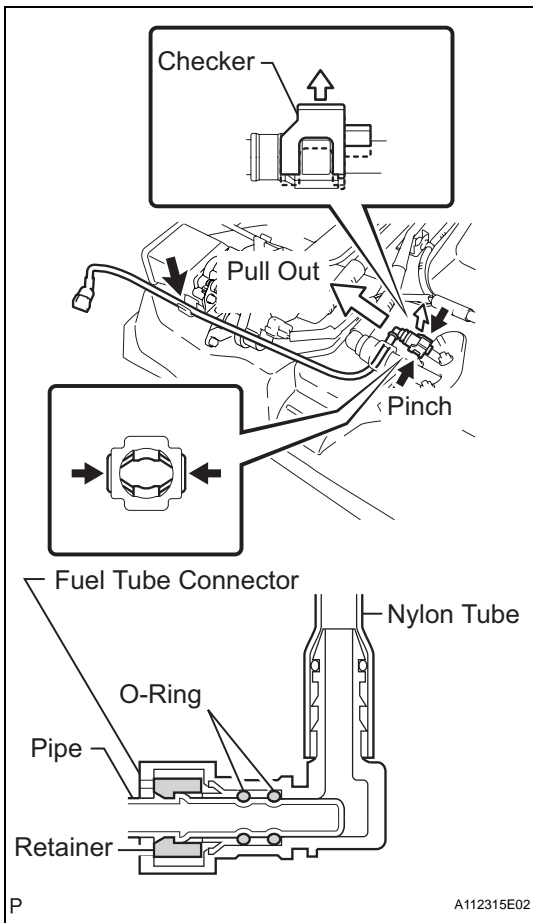

- (c) Disconnect the No. 2 fuel tank main tube from the clamp.
- (d) Remove the checker of the main tube connector from the pipe.
- (e) Pinch the retainer of the main tube connector, then pull out the fuel tube connector to disconnect the No. 2 fuel tank main tube from the pipe.

**NOTICE:**

- Remove dirt or foreign objects on the fuel tube connector before this procedure.
- Do not allow any scratches or foreign objects on the parts when disconnecting them as the fuel tube connector has the O-ring that seals the pipe.
- Perform this work by hand. Do not use any tools.
- Do not forcibly bend, twist or turn the nylon tube.
- Protect the connecting part by covering it with a plastic bag after disconnecting the No. 2 fuel tank main tube.
- If the fuel tube connector and pipe are stuck, push and pull them to release them.

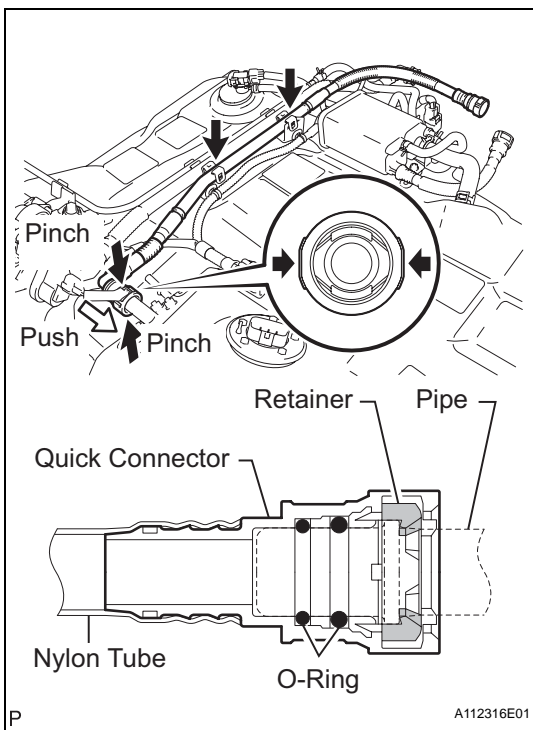
**9. REMOVE FUEL SUCTION TUBE SUB-ASSEMBLY**

- (a) Disconnect the fuel suction tube from the 2 No. 1 fuel tube clamps.
- (b) Pinch the retainer and pull out the suction tube connector with the quick connector pushed to the pipe side to disconnect the fuel suction tube from the pipe.

**NOTICE:**

- Remove dirt or foreign objects on the quick connector before this procedure.
- Do not allow any scratches or foreign objects on the parts when disconnecting them as the suction tube connector has the O-ring that seals the pipe.
- Perform this work by hand. Do not use any tools.
- Do not forcibly bend, twist or turn the nylon tube.
- Protect the connecting part by covering it with a plastic bag after disconnecting the fuel suction tube.
- If the quick connector and pipe are stuck, push and pull them to release them.

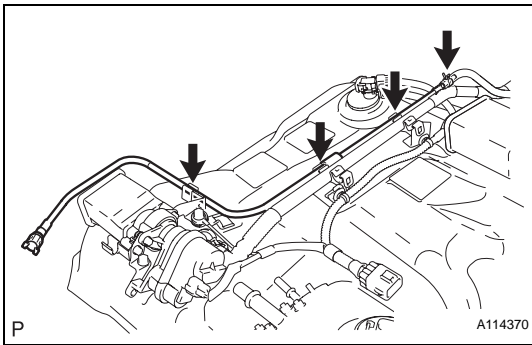
**10. REMOVE FUEL TANK TO CANISTER TUBE**

- (a) Disconnect the fuel tank to canister tube from the clamp.
- (b) Disconnect the fuel tank to canister tube from the 2 No. 1 fuel tube clamps.
- (c) Remove the fuel tank to canister tube from the fuel tank.

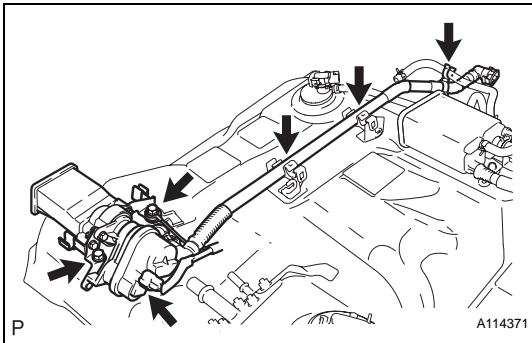
**11. REMOVE TRAP CANISTER WITH PUMP MODULE**

- (a) Disconnect the VSV connector.
- (b) Remove the clamp from the fuel tank vent hose and canister hose.
- (c) Remove the fuel tank vent hose from the 2 fuel tube clamps.
- (d) Remove the 2 bolts and trap canister with pump module and disconnect the ground terminal of the fuel tank wire.

- (e) Remove the gasket from the fuel tank.

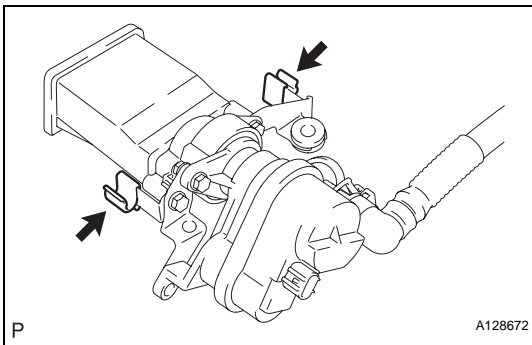
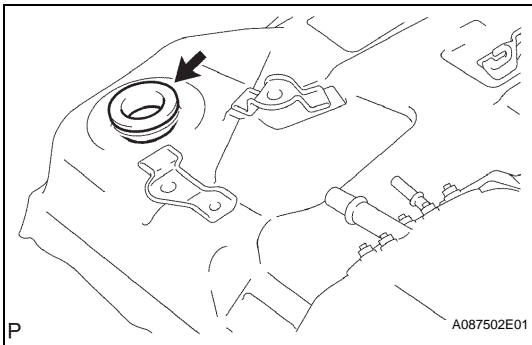

- (f) Remove the 2 clamps from the trap canister with pump module.

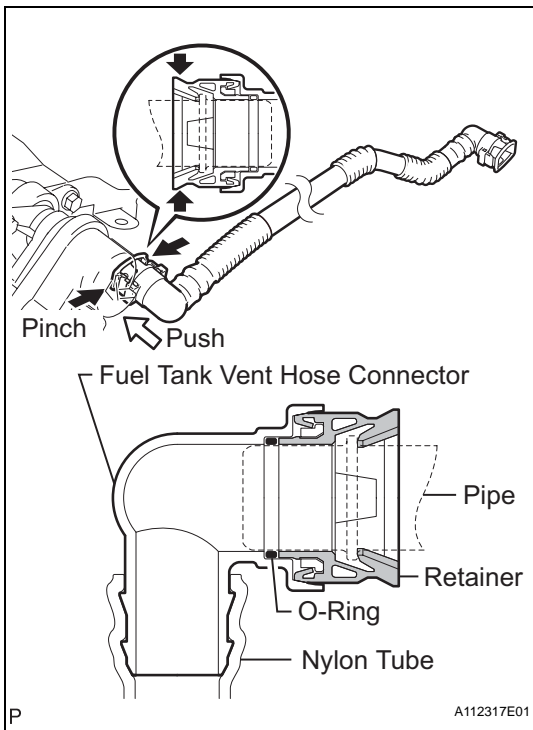

## 12. REMOVE FUEL TANK VENT HOSE

- Pinch the retainer and pull out the fuel tank vent hose connector with the fuel tank vent hose connector pushed to the fuel tank vent hose side to disconnect the fuel tank vent hose from the trap with outlet valve canister.

### NOTICE:

- Remove dirt of foreign objects on the fuel tank vent hose connector before this procedure.
- Do not allow any scratches or foreign objects on the parts when disconnecting them as the fuel tank vent hose connector has the O-ring that seals the pipe.
- Perform this work by hand. Do not use any tools.
- Do not forcibly bend, twist or turn the nylon tube.
- Protect the connecting part by covering it with a plastic bag after disconnecting the fuel tank vent hose.
- If the fuel tank vent hose connector and pipe are stuck, push and pull them to release them.

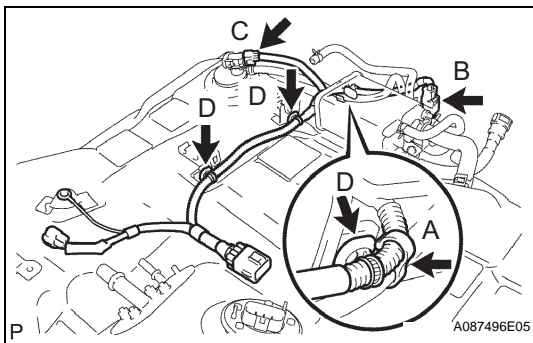

## 13. REMOVE FUEL TANK WIRE

- Remove the clamp as shown in the illustration A.
- Disconnect the VSV connector as shown in the illustration B.
- Disconnect the vapor pressure sensor connector as shown in the illustration C.
- Remove the 3 wire harness clamps as shown in the illustration D.

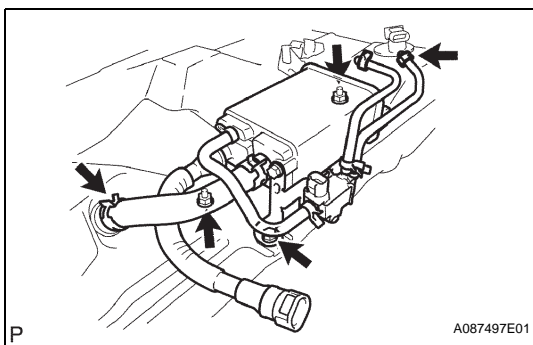

## 14. REMOVE CANISTER

- Disconnect the canister hose from the fuel tank retainer.
- Disconnect the No. 1 canister outlet hose from the fuel tank.
- Remove the bolt, 2 nuts and canister.

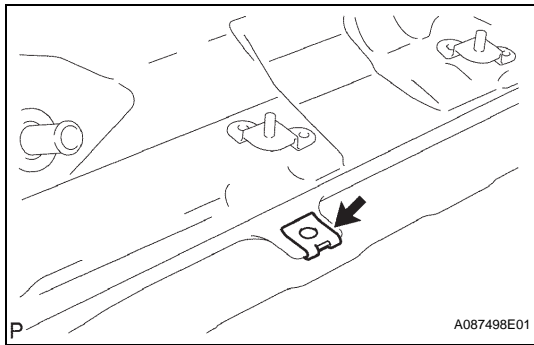

(d) Remove the nut from the fuel tank.

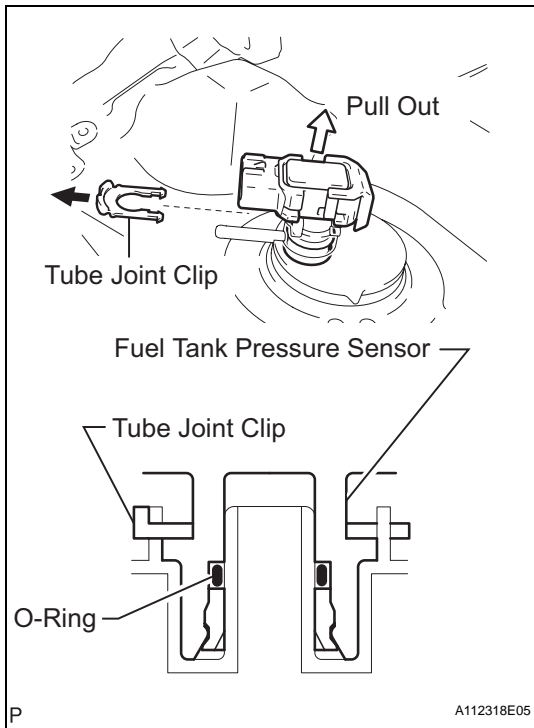

## 15. REMOVE FUEL TANK PRESSURE SENSOR

(a) Remove the tube joint clip, then pull out the fuel tank pressure sensor from the fuel tank retainer LH.

### NOTICE:

- Remove dirt or foreign objects on fuel tank pressure sensor before this procedure.
- Do not allow any scratches or foreign objects on the parts when disconnecting them as the fuel tank pressure sensor has the O-ring that seals the plug.
- Perform this work by hand. Do not use any tools.

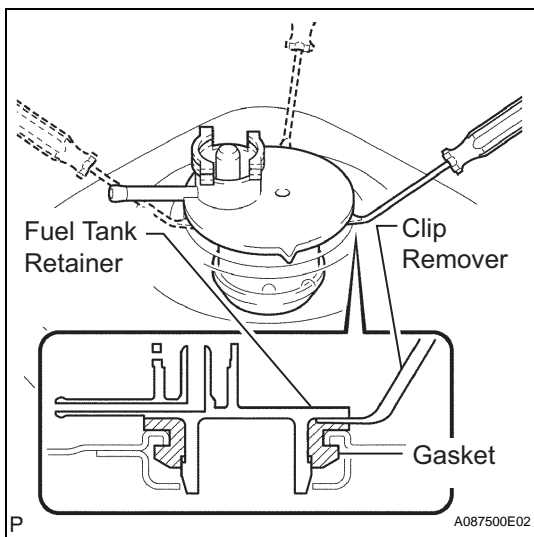

## 16. REMOVE FUEL TANK RETAINER LH

(a) Insert a clip remover between the fuel tank retainer and gasket, then remove the fuel tank retainer by lifting it little by little.

### NOTICE:

- The fuel tank retainer is made of resin and easily damaged if removed or installed forcibly. Handle the part correctly to ensure proper sealing.
- After removing the fuel tank retainer, check that the contact surface of the fuel tank retainer on the fuel tank is not damaged.

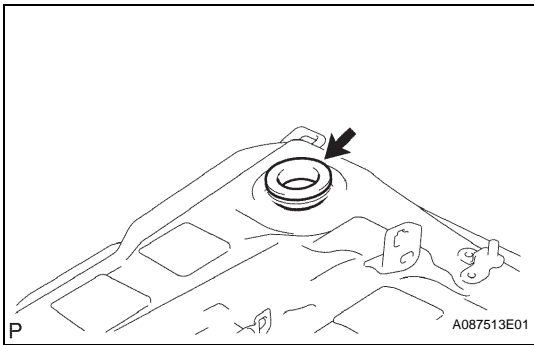

(b) Remove the gasket from the fuel tank.

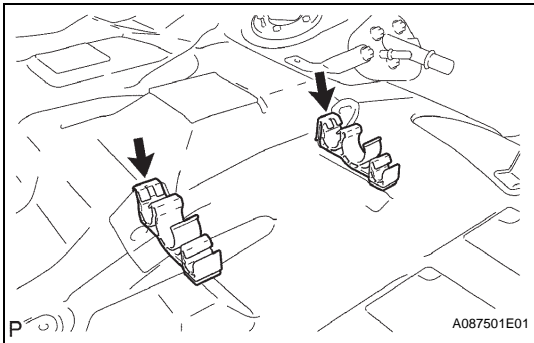

### 17. REMOVE NO. 1 FUEL TUBE CLAMP

(a) Remove the 2 clamps from the fuel tank.

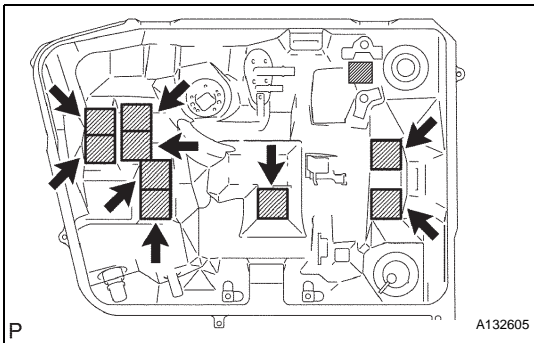

### 18. REMOVE NO. 1 FUEL TANK CUSHION

(a) Remove the 9 cushions from the fuel tank.

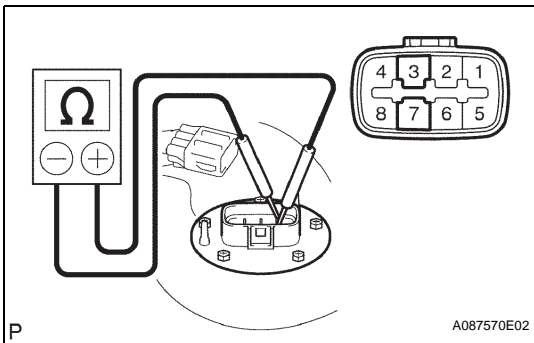

## INSPECTION

### 1. INSPECT FUEL TANK ASSEMBLY WITH FUEL PUMP

(a) Measure the resistance between terminals 3 and 7.

**Standard resistance:**

**0.2 to 3.0  $\Omega$  at 20°C (68°F)**

If the resistance is not as specified, replace the fuel tank assembly.

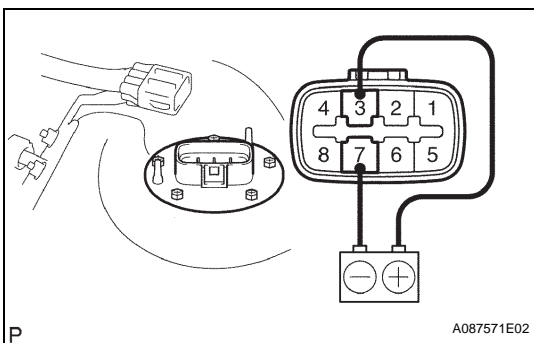

(b) Check that the motor operates when battery voltage is applied across the terminals.

**NOTICE:**

- Perform the check quickly (shorter than 10 seconds).
- Keep the battery as far away the fuel tank as possible.
- Always turn the voltage on and off on the battery side, not the fuel tank side.

If the motor does not operate, replace the fuel tank assembly.

## INSTALLATION

### 1. INSTALL NO. 1 FUEL TANK CUSHION

- (a) Install 9 new cushions to the fuel tank.

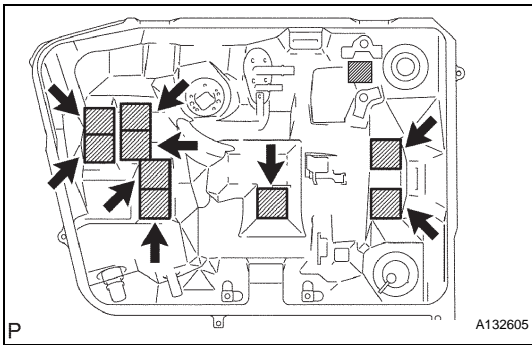

### 2. INSTALL NO. 1 FUEL TUBE CLAMP

- (a) Install the 2 clamps to the fuel tank.

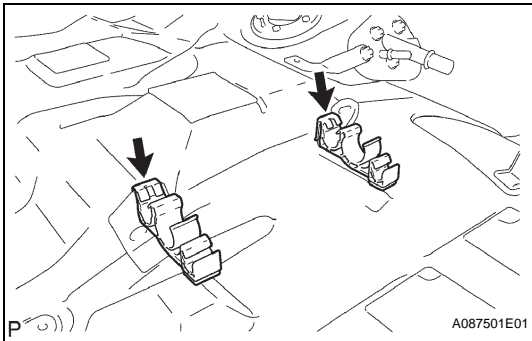

### 3. INSTALL FUEL TANK RETAINER LH

- (a) Install a new gasket to the fuel tank.  
 (b) While being careful that the gasket does not drop in the fuel tank, insert the fuel tank retainer LH to the fuel tank so the protrusion of the fuel tank retainer LH is in the middle of the 2 convex parts of the fuel tank.

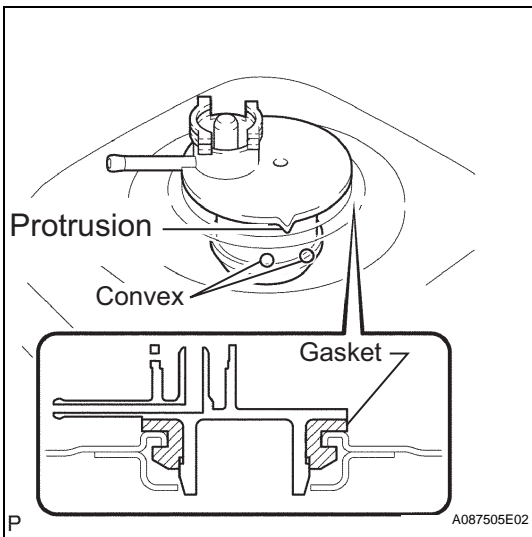

### 4. INSTALL FUEL TANK PRESSURE SENSOR

- (a) Push the fuel tank pressure sensor to the plug of the fuel tank retainer LH, and then install the tube joint clip.

#### NOTICE:

- Check that there are no scratches or foreign objects around the connected part of the fuel tank pressure sensor and fuel tank retainer LH before this procedure.
- Check that the fuel tank pressure sensor is securely inserted to the end.
- Check that the tube joint clip is on the collar of the fuel tank pressure sensor.
- After installing the tube joint clip, check that the fuel tank pressure sensor cannot be pulled out.

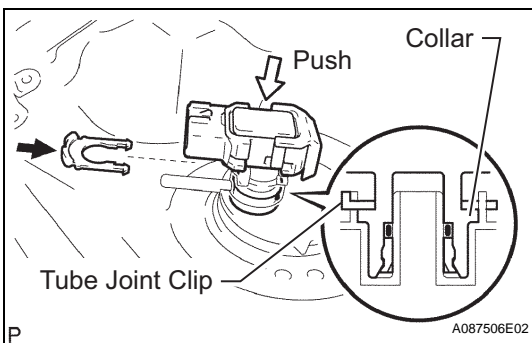



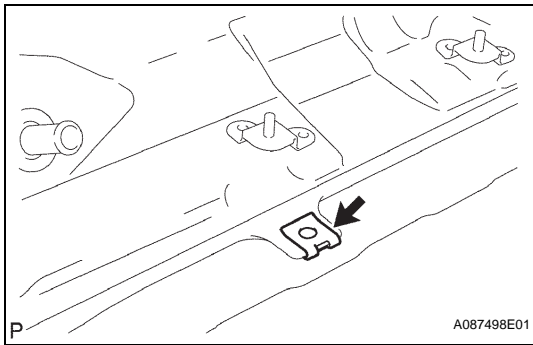

## 5. INSTALL CANISTER

- (a) Install the nut to the fuel tank.

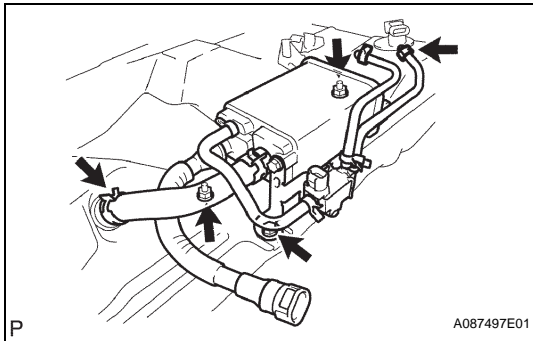

- (b) Install the canister with the bolt and 2 nuts.

**Torque: 6.0 N\*m (61 kgf\*cm, 53 in.\*lbf)**

- (c) Connect the No. 1 canister outlet hose to the fuel tank.  
 (d) Connect the canister hose to the fuel tank retainer.

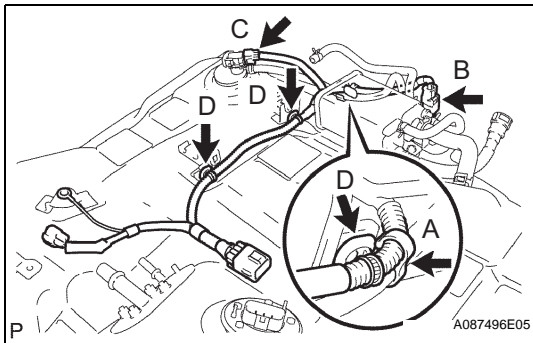

## 6. INSTALL FUEL TANK WIRE

- (a) Install the 3 wire harness clamps as shown in the illustration D.  
 (b) Connect the vapor pressure sensor connector as shown in the illustration C.  
 (c) Connect the VSV connector as shown in the illustration B.  
 (d) Install the clamp as shown in the illustration A.

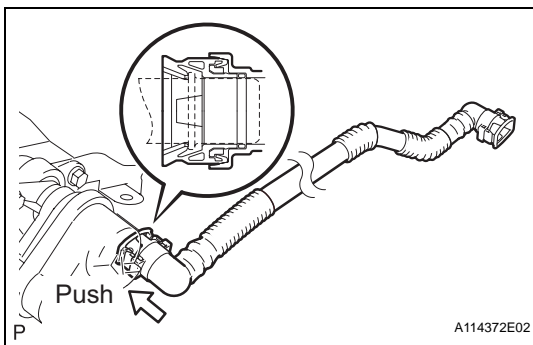

## 7. INSTALL FUEL TANK VENT HOSE

- (a) Align the fuel tank vent hose connector with the pipe, then push in the fuel tank vent hose connector until the retainer makes a "click" sound to install the fuel tank vent hose to the trap canister with pump module.

### NOTICE:

- Check that there are no scratches or foreign objects around the connected part of the fuel tank vent hose connector and pipe before this procedure.
- After connecting the fuel tank vent hose, check that the fuel tank vent hose is securely connected by pulling the fuel tank vent hose connector.

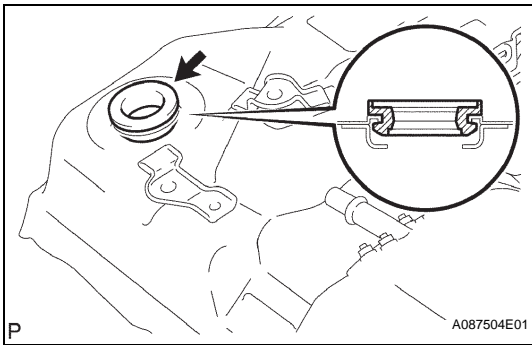

## 8. INSTALL TRAP CANISTER WITH PUMP MODULE

- (a) Install a new gasket to the fuel tank.
- (b) Insert the trap canister with pump module to the fuel tank.

### NOTICE:

**Be careful that the gasket does not drop in the fuel tank.**

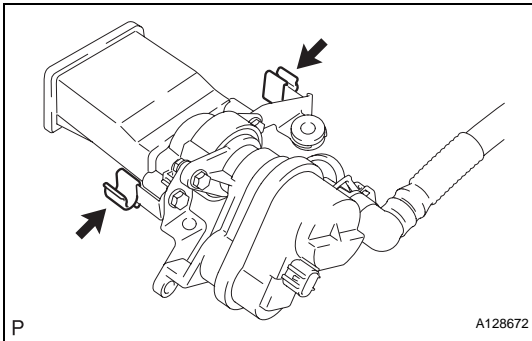

- (c) Install the 2 clamps to the trap canister with pump module.

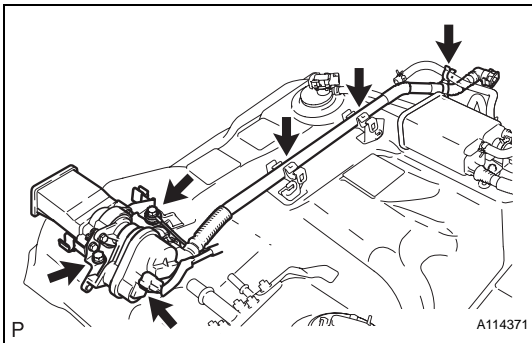

- (d) Install the trap canister with pump module and connect the ground terminal of the fuel tank wire with the 2 bolts.

**Torque: 6.0 N\*m (61 kgf\*cm, 53 in.\*lbf)**

- (e) Install the fuel tank vent hose to the 2 fuel tube clamps.
- (f) Install the clamp to the fuel tank vent hose and canister hose.
- (g) Connect the VSV connector.

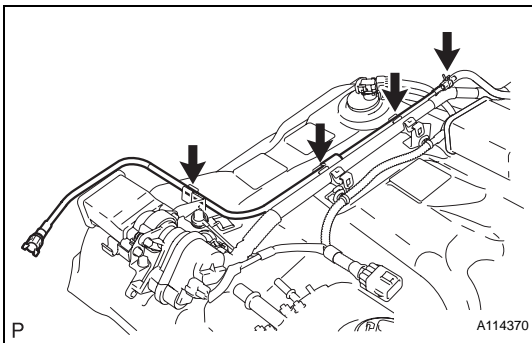

## 9. INSTALL FUEL TANK TO CANISTER TUBE

- (a) Install the fuel tank to canister tube to the canister's hose.
- (b) Connect the fuel tank to canister tube to the 2 No. 1 fuel tube clamps.

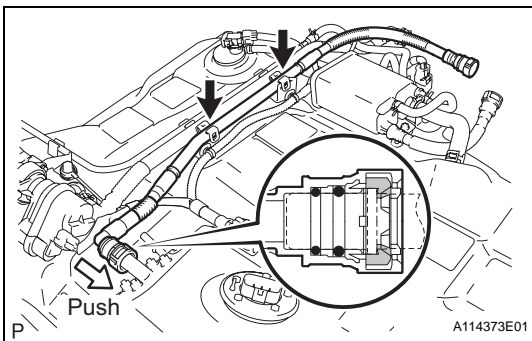

## 10. INSTALL FUEL SUCTION TUBE SUB-ASSEMBLY

- (a) Align the suction tube connector with the pipe, and then push in the suction tube connector until the retainer makes a "click" sound to install the fuel suction tube to the pipe.

### NOTICE:

- Check that there are no scratches or foreign objects around the connected part of the quick connector and pipe before this procedure.

- After connecting the fuel suction tube, check that the fuel suction tube is securely connected by pulling the suction tube connector.

- Connect the fuel suction tube to the 2 No. 1 fuel tube clamps.

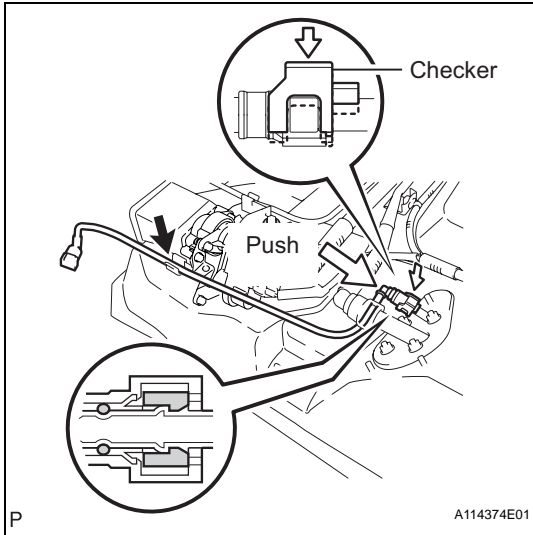

#### 11. INSTALL NO. 2 FUEL TANK MAIN TUBE SUB-ASSEMBLY

- Align the main tube connector with the pipe, and then push in the main tube connector until the retainer makes a "click" sound to install the No. 2 fuel tank main tube to the pipe.

##### NOTICE:

- Check that there are no scratches or foreign objects around the connected part of the fuel tube connector.
- After connecting the No. 2 fuel tank main tube, check that the No. 2 fuel tank main tube is securely connected by pulling the main tube connector.

- Install the checker to the pipe.
- Connect the No. 2 fuel tank main tube to the clamp.

- Connect the connector clamp to the rear fuel tank bracket.

- Install the rear fuel tank bracket with the 3 nuts.

**Torque: 6.0 N\*m (61 kgf\*cm, 53 in.\*lbf)**

#### 12. INSTALL FUEL TANK ASSEMBLY

- Set the fuel tank to a transmission jack.
- Operate the transmission jack, and then install the fuel tank to the vehicle.
- Operate the transmission jack, and then connect the fuel tank inlet pipe.

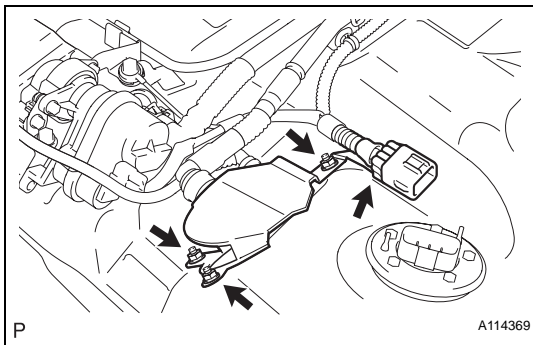

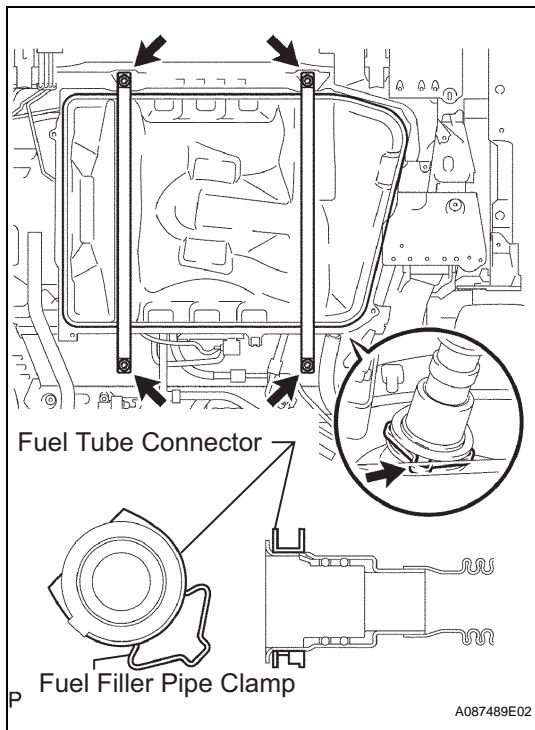

- (d) Install the No. 1 fuel tank band RH and LH with the 4 bolts.

**Torque: 39 N\*m (400 kgf\*cm, 29 ft.\*lbf)**

- (e) Install the fuel tube connector and fuel filler pipe clamp to the fuel tank inlet pipe.

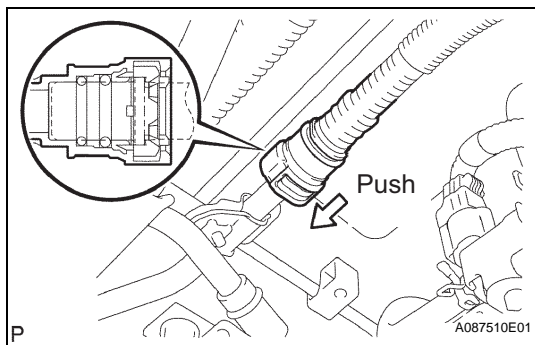

- (f) Connect the No. 1 canister tube.

- (1) Align the No. 1 canister tube connector with the pipe, and then push in the No. 1 canister tube connector until the retainer makes a "click" sound to connect the No. 1 canister tube to the fuel tank to filler pipe.

**NOTICE:**

- Check that there are no scratches or foreign objects around the connected part of the No. 1 canister tube connector and pipe before this procedure.
- After connecting the No. 1 canister tube, check that the No. 1 canister tube is securely connected by pulling the No. 1 canister tube connector.

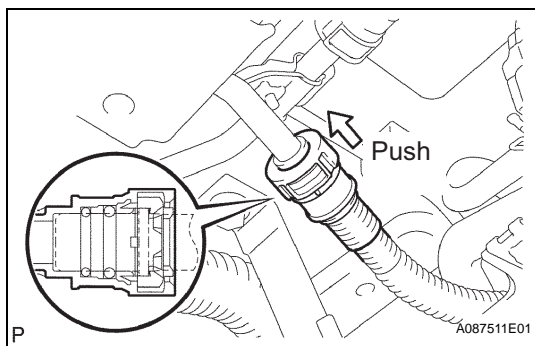

- (g) Connect the fuel suction tube.

- (1) Align the suction tube connector with the pipe, and then push in the suction tube connector until the retainer makes a "click" sound to connect the fuel suction tube to the fuel tank to filler pipe.

**NOTICE:**

- Check that there are no scratches or foreign objects around the connected part of the suction tube connector and pipe before this procedure.
- After connecting the fuel suction tube, check that the fuel suction tube is securely connected by pulling the suction tube connector.

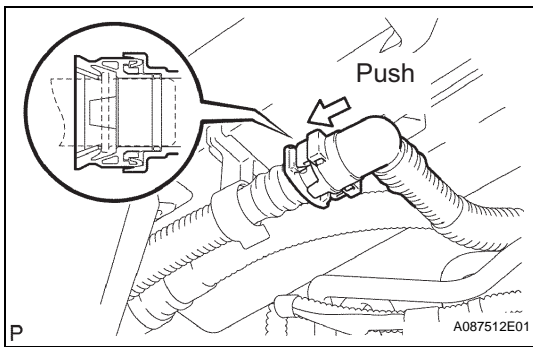

- (h) Connect the fuel tank vent hose.
- (1) Align the fuel tank vent hose connector with the pipe, and then push in the fuel tank vent hose connector until the retainer makes a "click" sound to connect the fuel tank vent hose to the canister filter.

**NOTICE:**

- Check that there are no scratches or foreign objects around the connected part of the fuel tank vent hose connector and pipe before this procedure.
- After connecting the fuel tank vent hose, check that the fuel tank vent hose is securely connected by pulling the vent hose connector.

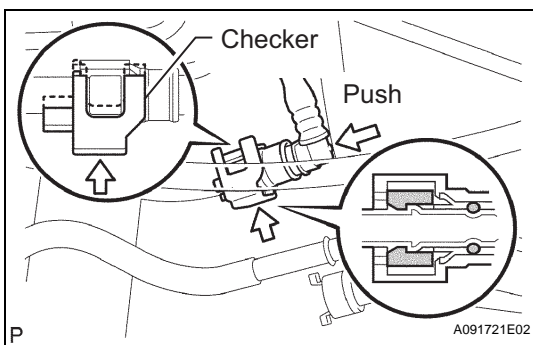

- (i) Connect the No. 2 fuel tank main tube.
- (1) Align the fuel tube connector with the pipe, and then push in the fuel tube connector until the retainer makes a "click" sound to connect the No. 2 fuel tank main tube to the pipe.

**NOTICE:**

- Check that there are no scratches or foreign objects around the connected part of the fuel tube connector and pipe before this procedure.
- After connecting the No. 2 fuel tank main tube, check that the No. 2 fuel tank main tube is securely connected by pulling the quick connector.

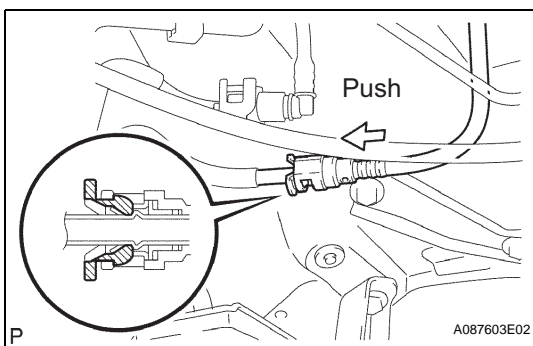

- (j) Install the checker to the pipe.
- (k) Connect the fuel tank to canister tube.
- (1) Align the fuel tank to canister tube connector with the pipe, and then push in the fuel tank to canister tube connector until the retainer makes a "click" sound to connect the fuel tank to canister tube to the pipe.

**NOTICE:**

- Check that there are no scratches or foreign objects around the connected part of the fuel tank to canister tube connector and pipe before this procedure.
- After connecting the fuel tank to canister tube, check that the fuel tank to canister tube is securely connected by pulling the quick connector.

13. INSTALL FRONT EXHAUST PIPE ASSEMBLY (See page [EX-3](#))

14. CONNECT CABLE TO NEGATIVE BATTERY TERMINAL

15. CHECK FOR FUEL LEAKS (See page [FU-8](#))

16. CHECK FOR EXHAUST GAS LEAKS

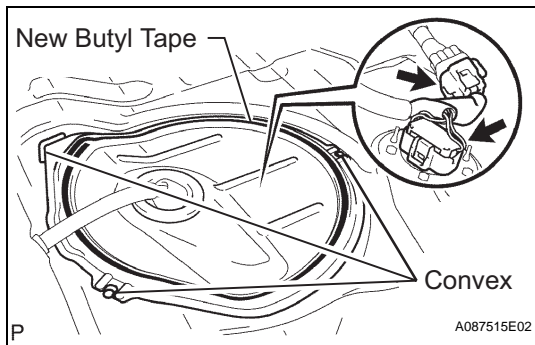

17. INSTALL FRONT FLOOR PANEL BRACE (See page [EX-4](#))

18. INSTALL INSTRUMENT PANEL FINISH PANEL LOWER CENTER (See page [IP-21](#))

19. INSTALL REAR FLOOR SERVICE HOLE COVER

- (a) Attach new butyl tape to the rear floor service hole cover.
- (b) Connect the wire to wire connector.
- (c) Connect the fuel pump connector.
- (d) Install the rear floor service hole cover while adjusting it to the 3 convex parts of the floor panel.

**NOTICE:**

**Be careful that the rear floor service hole cover does not overlap the convex parts of the floor panel when installing.**

20. INSTALL REAR SEAT CUSHION ASSEMBLY (See page [SE-23](#))

21. PERFORM INITIALIZATION

- (a) Perform initialization (see page [IN-32](#)).

**NOTICE:**

**Certain systems need to be initialized after disconnecting and reconnecting the cable from the negative (-) battery terminal.**