

Last Modified: 01-14-2019	6.8:8.0.48	Doc ID: RM100000000S1MH
Model Year Start: 2016	Model: Prius	Prod Date Range: [11/2015 -]
Title: WIPER / WASHER: FRONT WIPER MOTOR: REMOVAL; 2016 - 2019 MY Prius [11/2015 -]		

REMOVAL

CAUTION / NOTICE / HINT

NOTICE:

Make sure to hold the front wiper arm while lifting it as lifting the front wiper arm by the front wiper blade may damage or deform the front wiper blade.

PROCEDURE

1. REMOVE FRONT WIPER ARM HEAD CAP

(a) Using a screwdriver, disengage the 3 claws to remove the front wiper arm head cap.

HINT:

- Tape the screwdriver tip before use.
- Use the same procedure for the RH side and LH side.

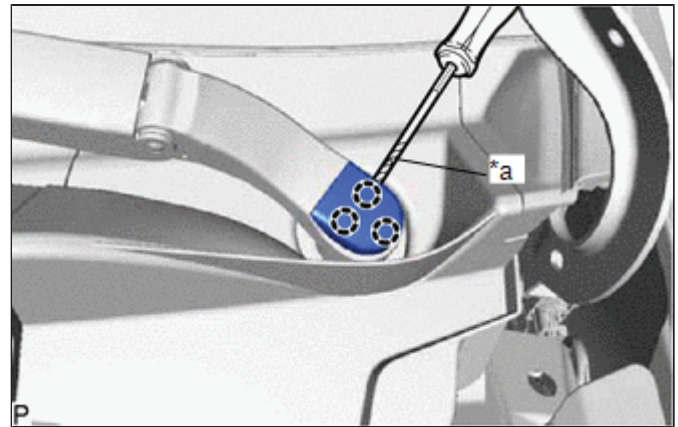

*a	Protective Tape
----	-----------------

2. REMOVE FRONT WIPER ARM AND BLADE ASSEMBLY LH

(a) Remove the nut and front wiper arm and blade assembly LH.

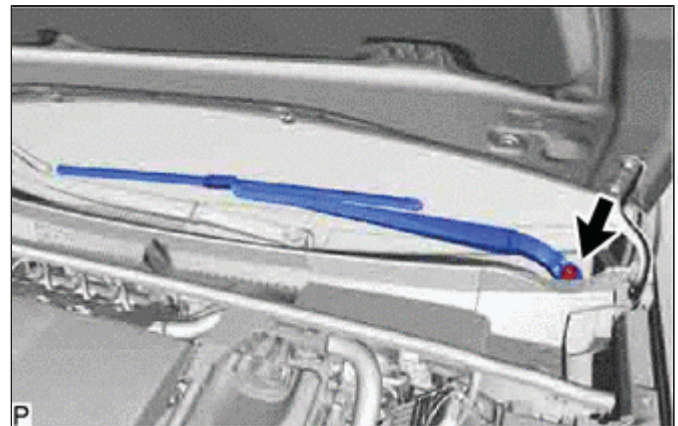

3. REMOVE FRONT WIPER ARM AND BLADE ASSEMBLY RH

- (a) Remove the nut and front wiper arm and blade assembly RH.

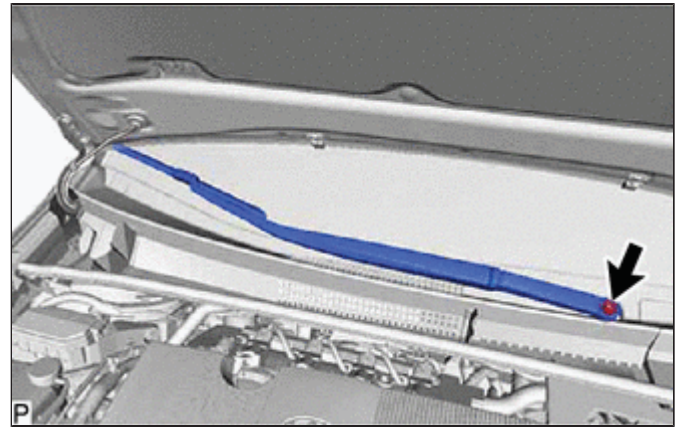

4. REMOVE COWL WATER EXTRACT SHIELD LH

NOTICE:

To prevent damage to the windshield glass, remove any foreign matter (sand, dust, etc.) from around the contacting surfaces of the cowl water extract shield LH and windshield glass.

- (a) Apply protective tape around the cowl water extract shield LH.

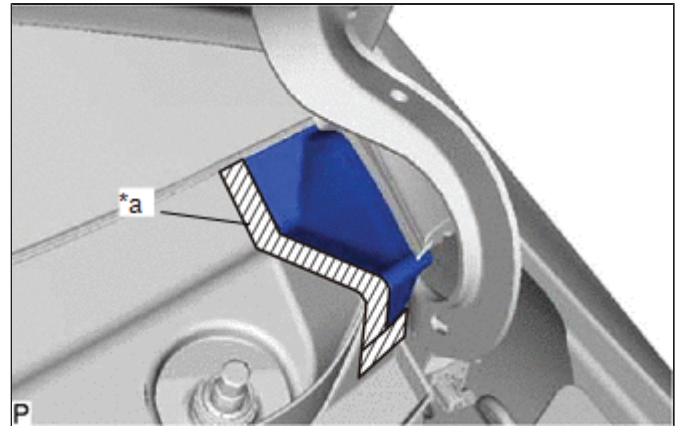

*a	Protective Tape
----	-----------------

- (b) Using a moulding remover, disengage the claw as shown in the illustration.

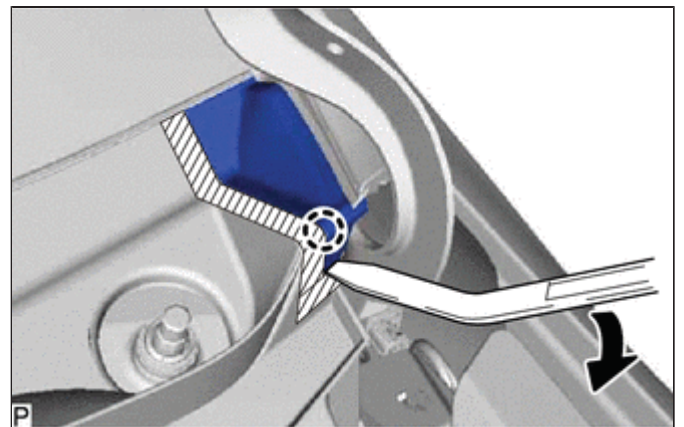

(c) Using a moulding remover, disengage the cowl water extract shield LH from the windshield glass.

NOTICE:

Do not forcibly pry up the cowl water extract shield LH as it may be deformed or damaged.

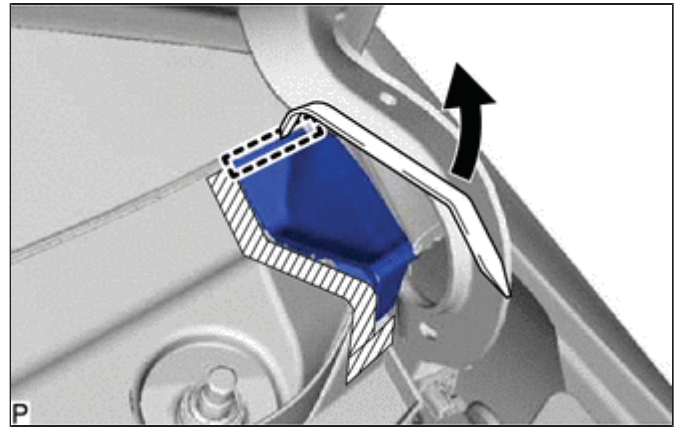

(d) Disengage the claw and guide.

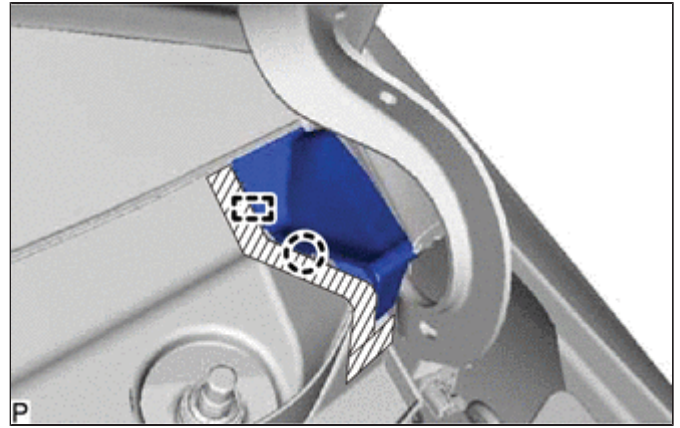

(e) Remove the cowl water extract shield LH as shown in the illustration.

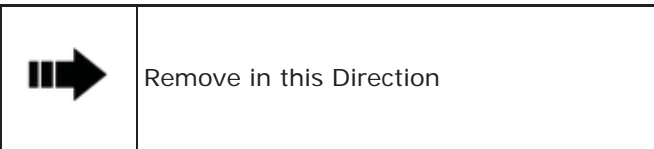
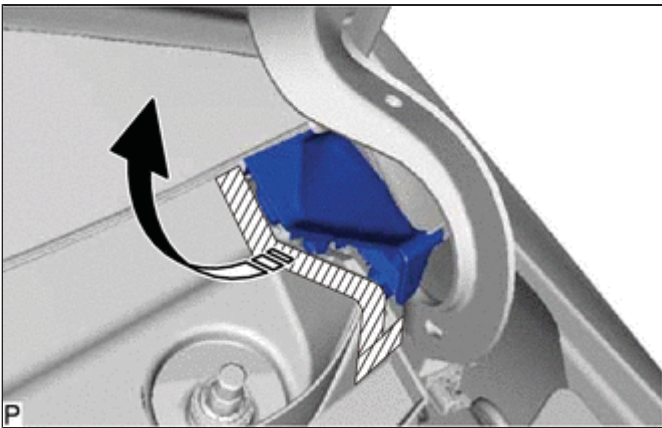

5. REMOVE COWL WATER EXTRACT SHIELD RH

HINT:

Use the same procedure as for the LH side.

6. REMOVE COWL TOP VENTILATOR LOUVER SUB-ASSEMBLY

NOTICE:

To prevent damage to the windshield glass, remove any foreign matter (sand, dust, etc.) from around the contacting surfaces of the cowl top ventilator louver sub-assembly and windshield glass.

(a) Remove the 2 clips.

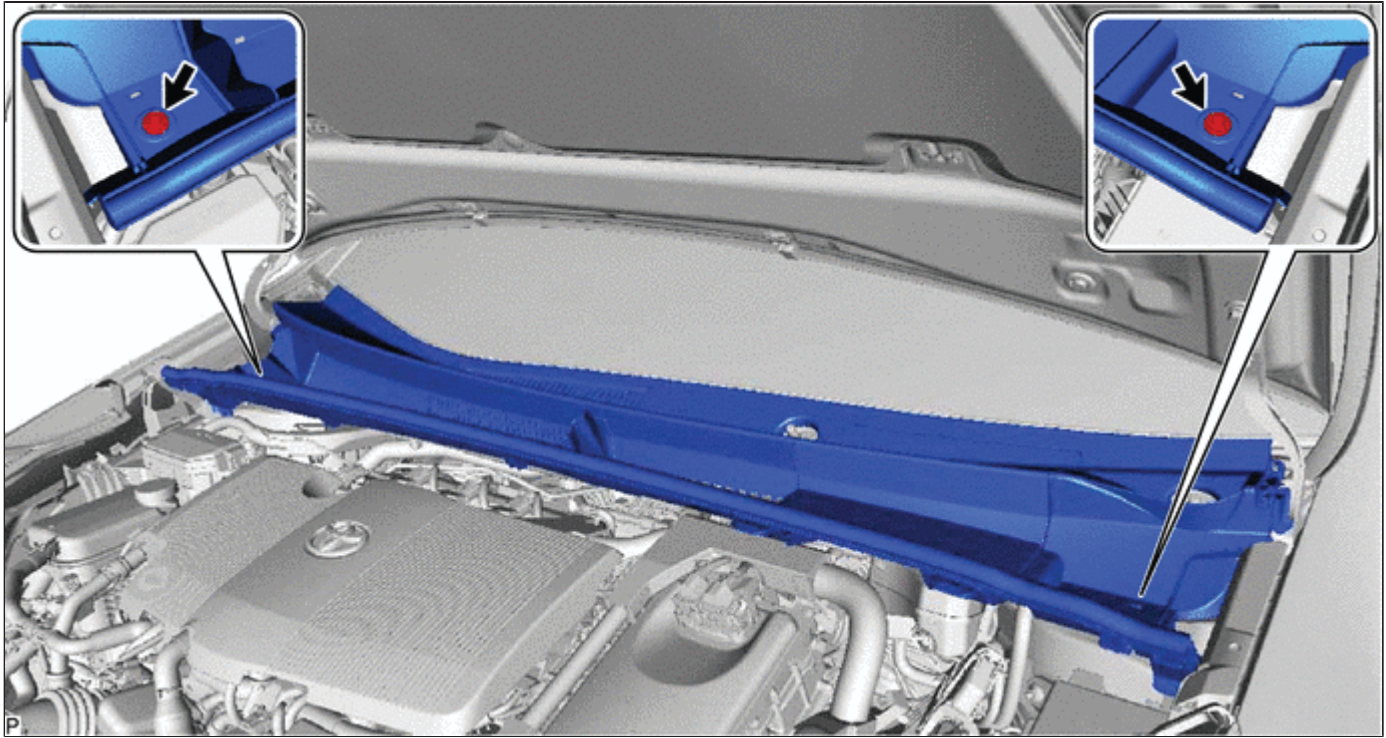

(b) Close the hood sub-assembly.

(c) Apply protective tape to a moulding remover as shown in the illustration.

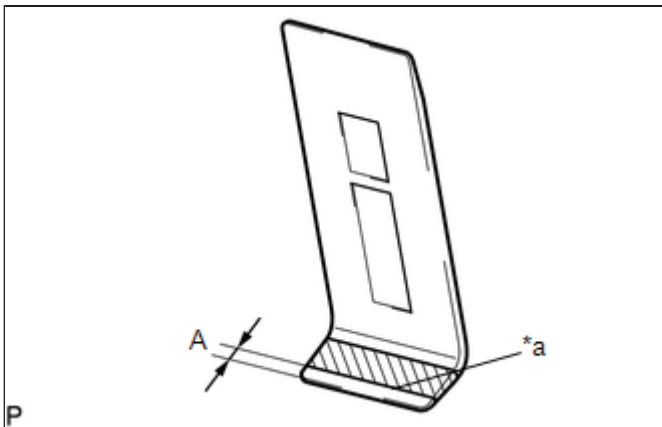

*a	Edge of Protective Tape
	Protective Tape

Standard Dimension:

AREA	DIMENSION
A	4.0 mm (0.157 in.)

(d) Insert the moulding remover at the starting position until the edge of the protective tape is aligned with the cowl top

ventilator louver sub-assembly as shown in the illustration.

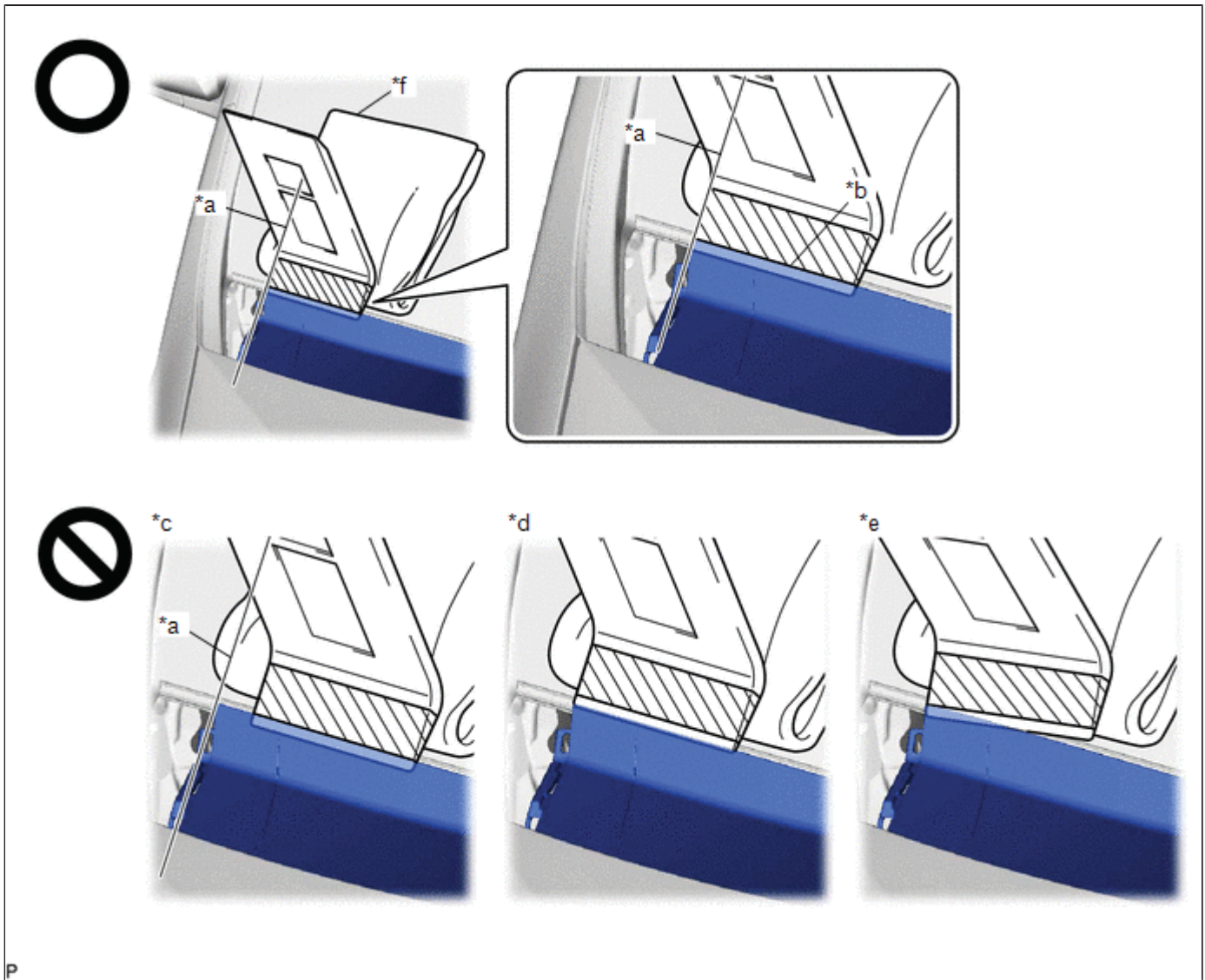

*a	Starting Position: Side of Cowl Top Ventilator Louver Sub-assembly and Moulding Remover Aligned	*b	Inserted to Edge of Protective Tape
*c	Not Inserted at Starting Position	*d	Not Inserted to Edge of Protective Tape
*e	Not Inserted Straight	*f	Piece of Cloth or Equivalent
	Protective Tape	-	-

NOTICE:

- To prevent damage to the windshield glass, set a piece of cloth between the moulding remover and windshield glass.
- Make sure to insert the moulding remover until the edge of protective tape is aligned with the cowl top ventilator louver sub-assembly, otherwise the cowl top ventilator louver sub-assembly may be deformed or damaged.

(e) While pushing the moulding remover in the direction indicated by the arrow (A), push the moulding remover in the direction indicated by the arrow (B) to disengage the cowl top ventilator louver sub-assembly.

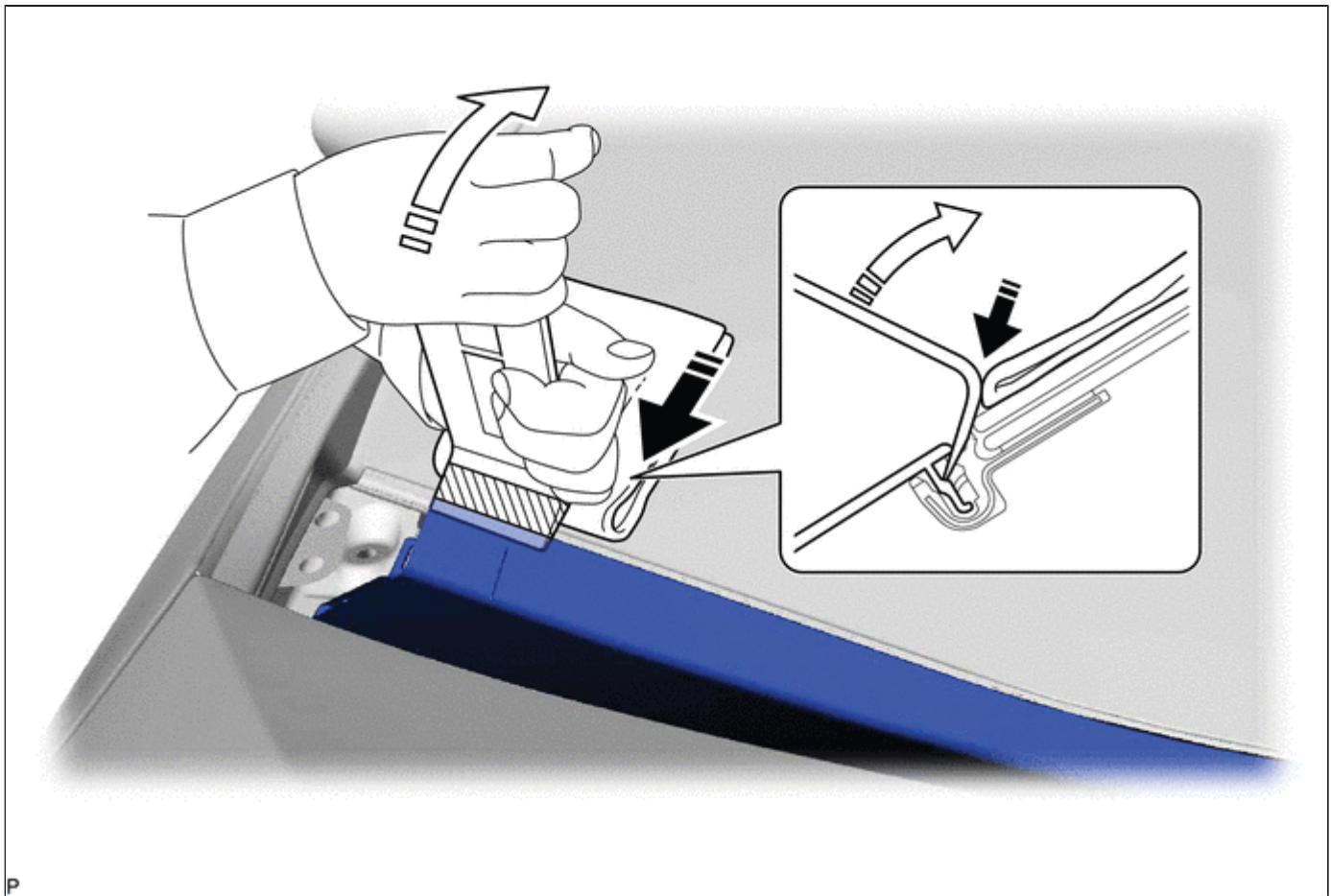

P

	Push in this Direction (A)		Push in this Direction (B)
--	----------------------------	--	----------------------------

NOTICE:

- Make sure to repeat this procedure to disengage the entire cowl top ventilator louver sub-assembly.
- Make sure to perform this procedure while pushing the moulding remover in the direction indicated by the arrow (A), otherwise the cowl top ventilator louver sub-assembly may be deformed or damaged.
- Make sure not to pry the cowl top ventilator louver sub-assembly more than necessary to disengage it, otherwise it may be deformed or damaged.

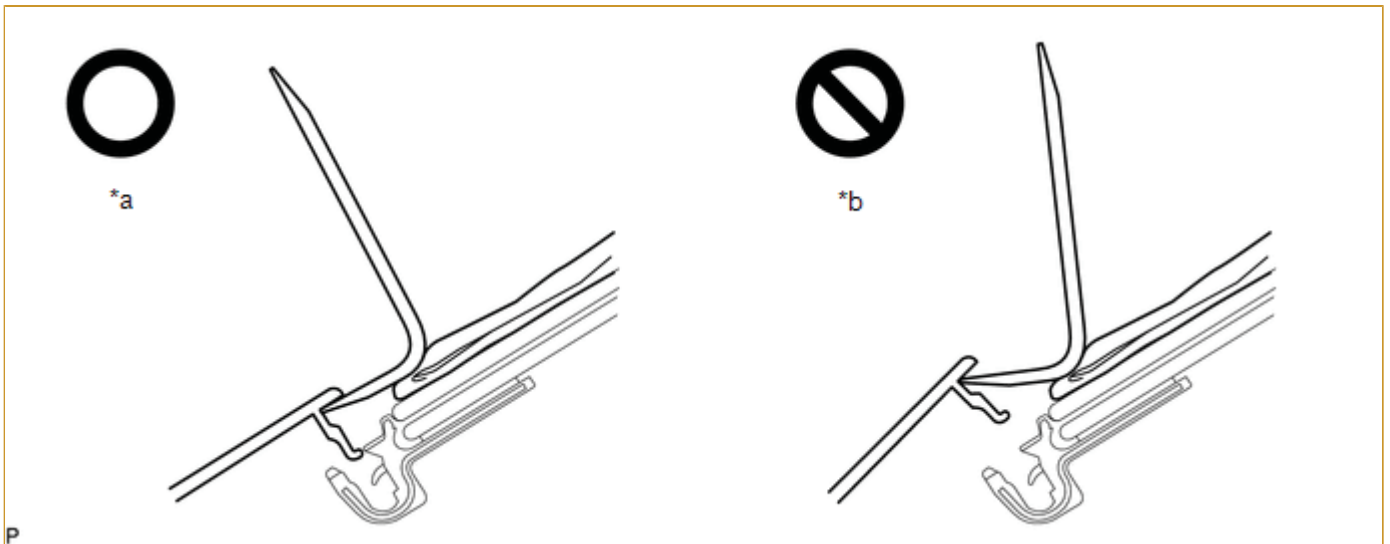

P

*a

Pried Until Disengaged

*b

Pried Excessively

(f) Using the moulding remover, repeatedly pry up the cowl top ventilator louver sub-assembly while gradually moving the moulding remover half of its width laterally toward the center of the vehicle and then repeat the procedure from the other side of the vehicle as shown in the illustration to disengage the cowl top ventilator louver sub-assembly from the windshield glass.

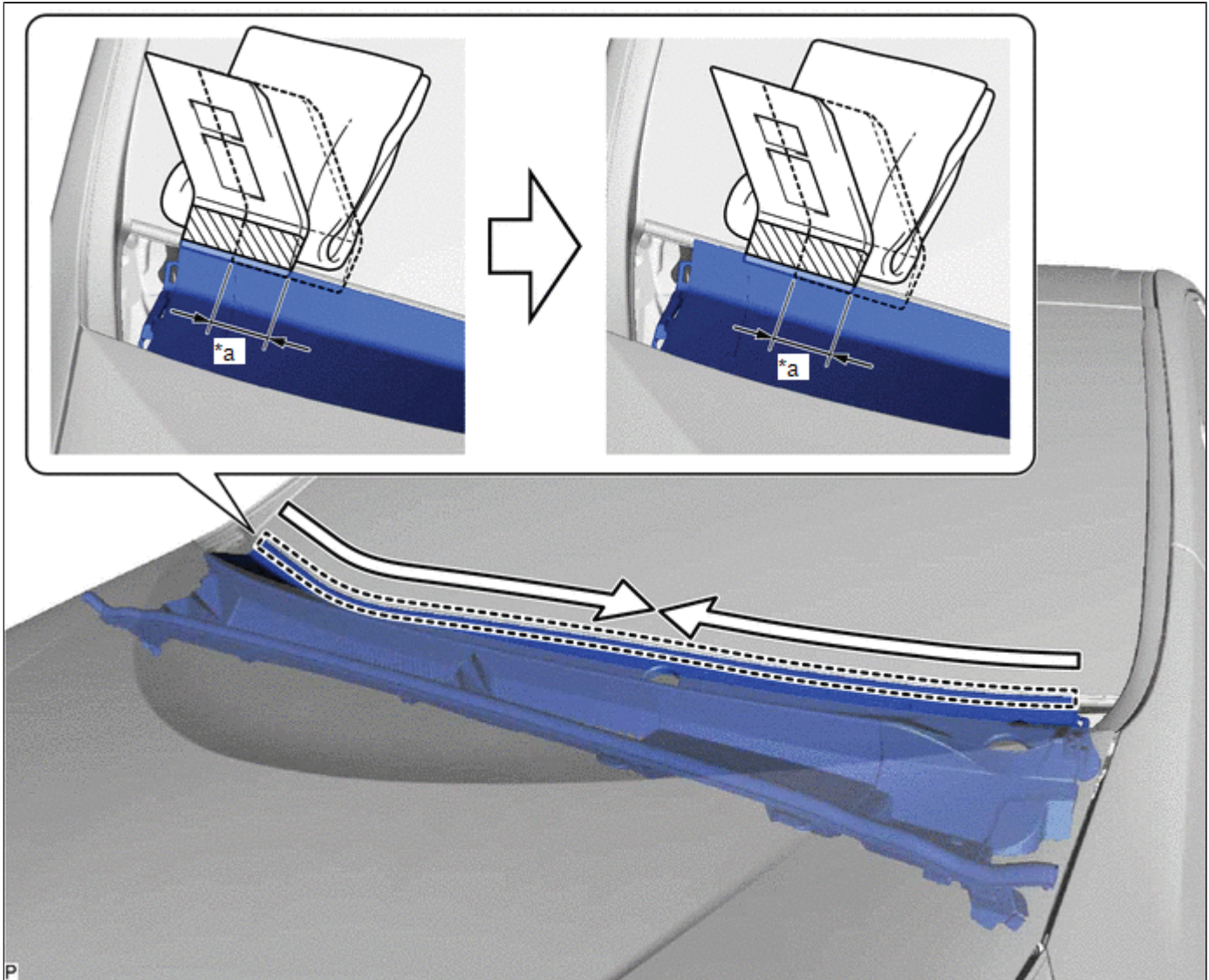

*a	Half Width of Moulding Remover	-	-
➔	Order of Removal	-	-

NOTICE:

- Make sure to move the moulding remover only half of its width laterally after prying up the cowl top ventilator louver sub-assembly, otherwise the cowl top ventilator louver sub-assembly may be damaged or deformed.
- Make sure not to lift up or pull the cowl top ventilator louver sub-assembly by hand before it is completely disengaged, otherwise it may be deformed or damaged.

(g) Open the hood sub-assembly.

(h) Disengage the 4 guides and remove the cowl top ventilator louver sub-assembly as shown in the illustration.

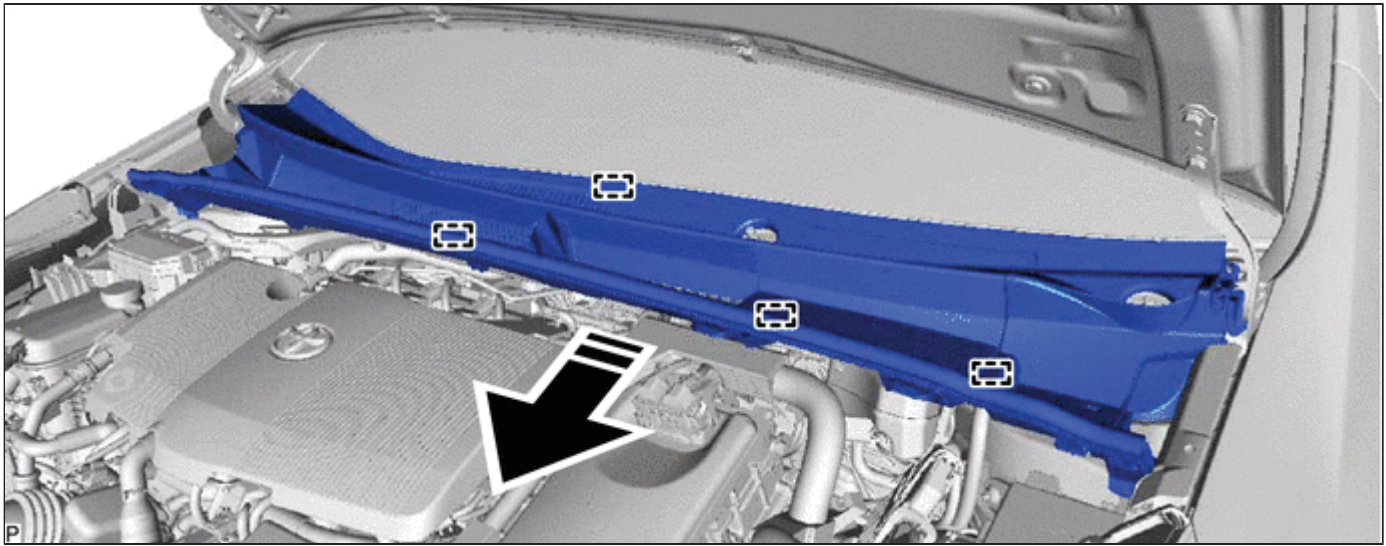

	Remove in this Direction	-	-
---	--------------------------	---	---

NOTICE:

When removing the cowl top ventilator louver sub-assembly, it may contact the brake master cylinder reservoir filler cap assembly and cause it to fall off. Check the installation condition of the brake master cylinder reservoir filler cap assembly after removing the cowl top ventilator louver sub-assembly.

7. REMOVE WINDSHIELD WIPER MOTOR AND LINK ASSEMBLY

(a) Remove the 2 bolts.

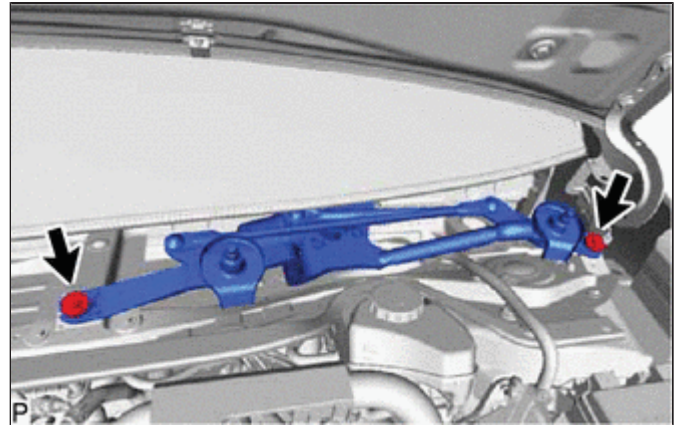

(b) Disengage the motor grommet as shown in the illustration.

NOTICE:

Be careful not to damage the windshield glass when removing the windshield wiper motor and link assembly.

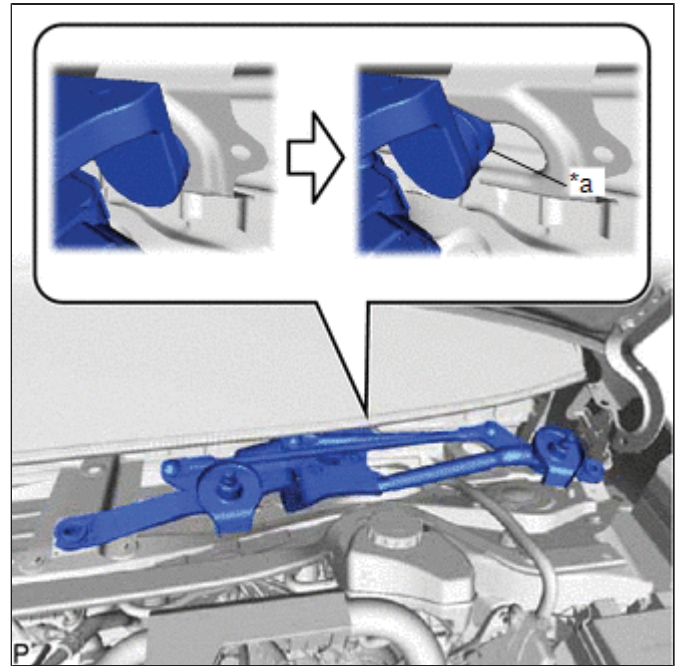

*a	Motor Grommet
----	---------------

(c) Disconnect the connector to remove the windshield wiper motor and link assembly.

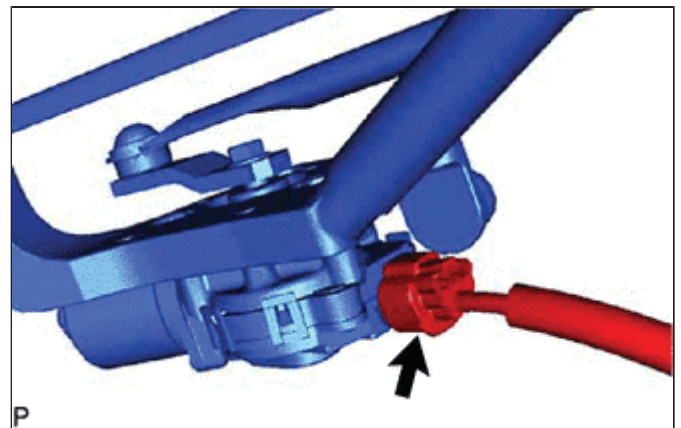

8. REMOVE WINDSHIELD WIPER MOTOR ASSEMBLY

(a) Using a screwdriver, separate the No. 1 windshield wiper link rod from the pivot of the windshield wiper motor assembly as shown in the illustration.

HINT:

Tape the screwdriver tip before use.

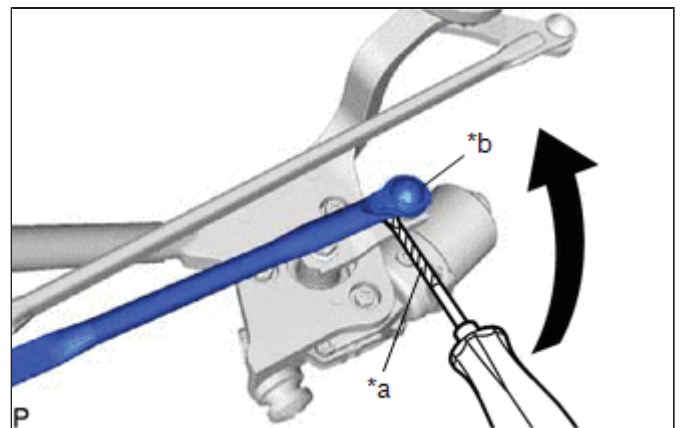

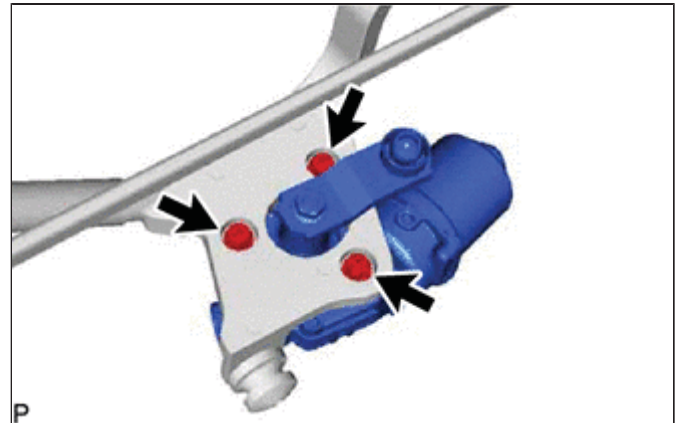

*a	Protective Tape
*b	Pivot of Windshield Wiper Motor Assembly

(b) Remove the 3 bolts.

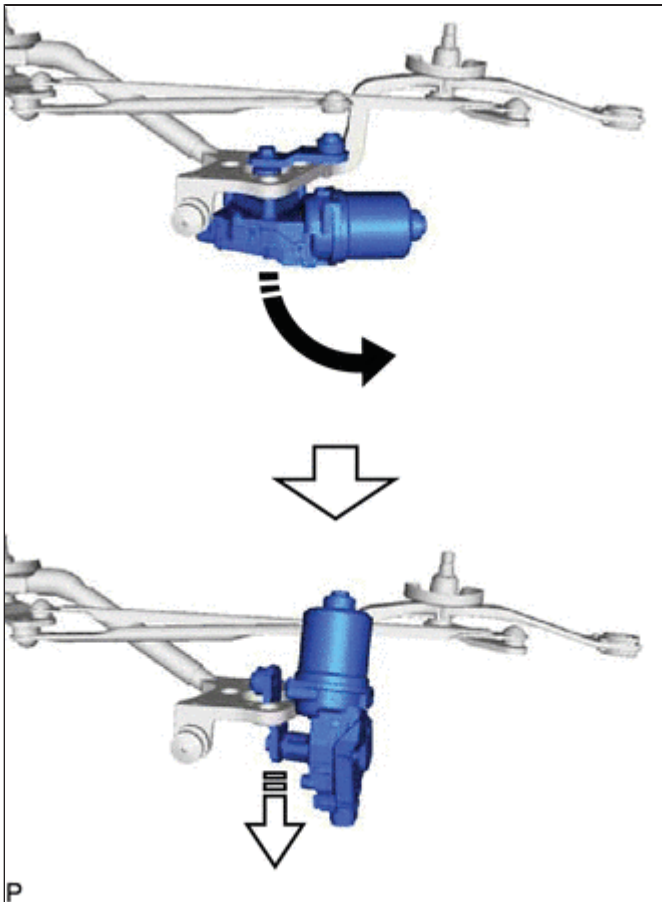

(c) Move the windshield wiper motor assembly in the direction indicated by the arrow (1), then pull the windshield wiper motor assembly in the direction indicated by the arrow (2) shown in the illustration to remove it from the windshield wiper link assembly.



	Remove in this Direction (1)
--	------------------------------

Last Modified: 01-14-2019

6.8:8.0.48

Doc ID: RM100000000S1MF

Model Year Start: 2016

Model: Prius

Prod Date Range: [11/2015 -]

Title: WIPER / WASHER: FRONT WIPER MOTOR: COMPONENTS; 2016 - 2019 MY Prius [11/2015 -]

COMPONENTS

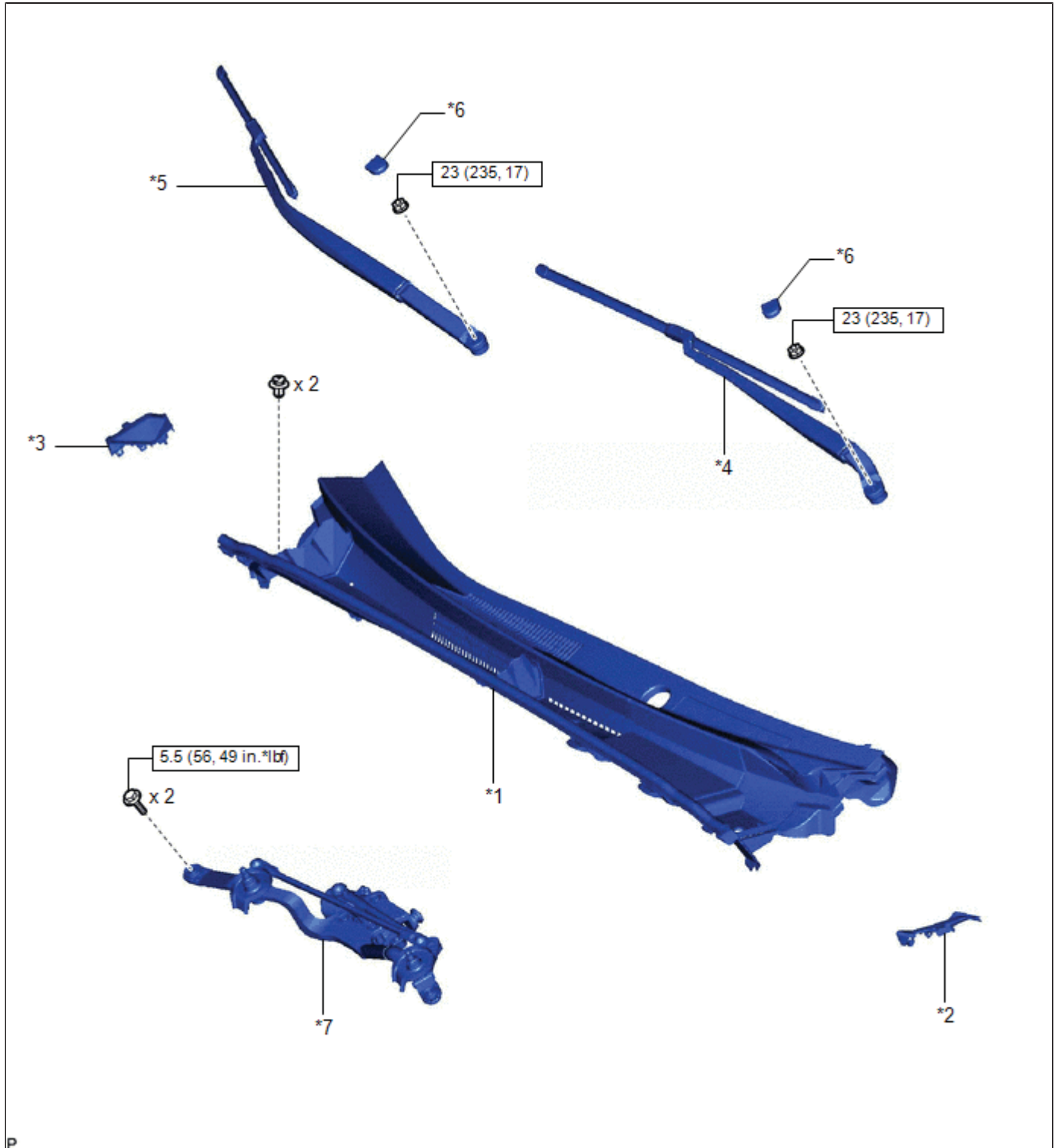

ILLUSTRATION

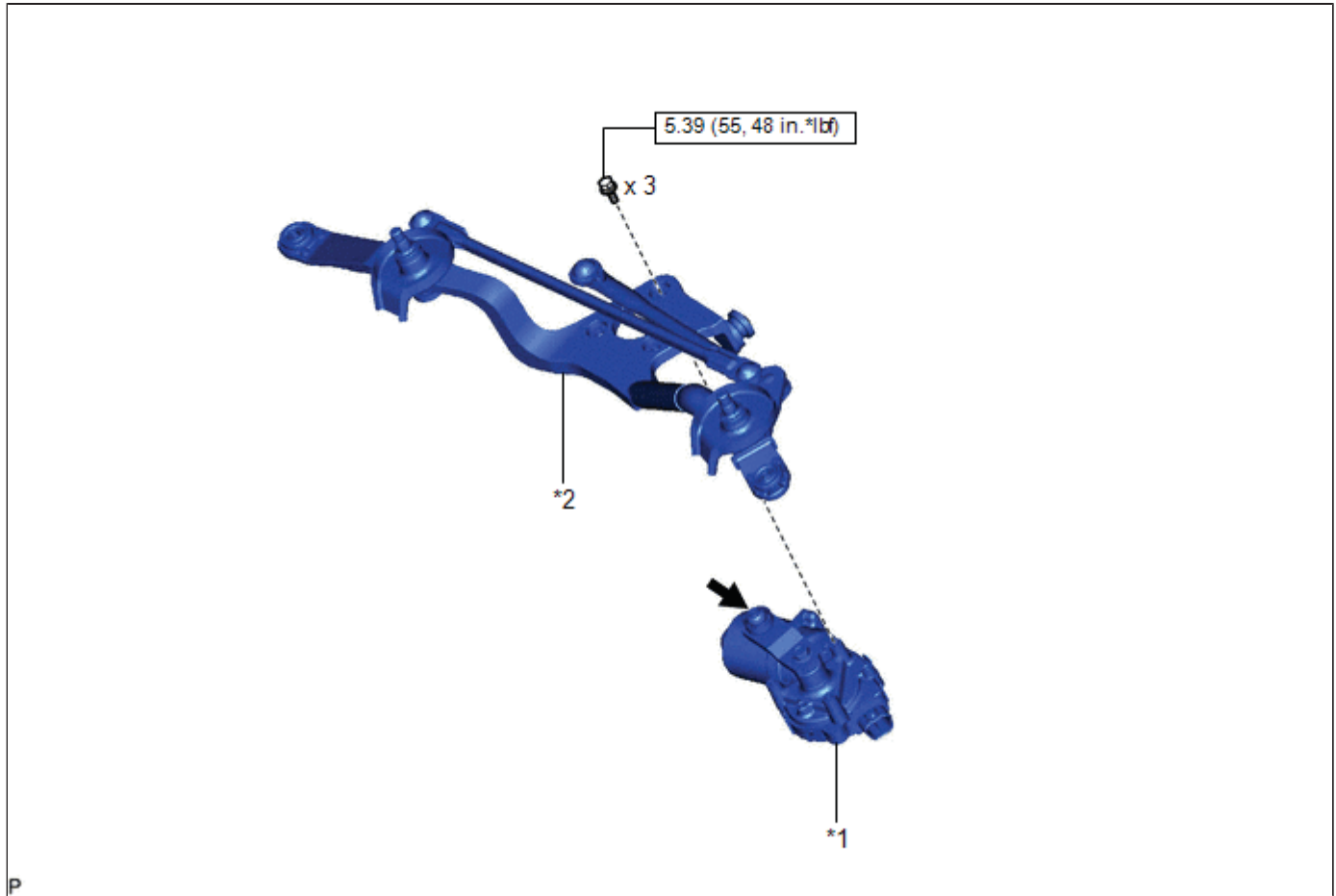

*1	ASSEMBLY	*2	COWL WATER EXTRACT SHIELD LH
*3	COWL WATER EXTRACT SHIELD RH	*4	FRONT WIPER ARM AND BLADE ASSEMBLY LH
*5	FRONT WIPER ARM AND BLADE ASSEMBLY RH	*6	FRONT WIPER ARM HEAD CAP
*7	WINDSHIELD WIPER MOTOR AND LINK ASSEMBLY	-	-
	N*m (kgf*cm, ft.*lbf): Specified torque	-	-

ILLUSTRATION



*1	WINDSHIELD WIPER MOTOR ASSEMBLY	*2	WINDSHIELD WIPER LINK ASSEMBLY
	N*m (kgf*cm, ft.*lbf): Specified torque		MP grease



Last Modified: 01-14-2019	6.8:8.0.48	Doc ID: RM100000000TKJN
Model Year Start: 2016	Model: Prius	Prod Date Range: [11/2015 -]
Title: WIPER / WASHER: FRONT WIPER MOTOR: INSPECTION; 2016 - 2019 MY Prius [11/2015 -]		

INSPECTION

CAUTION / NOTICE / HINT

CAUTION:

Ensure that fingers or articles of clothing do not get caught in moving parts when performing this test.

PROCEDURE

1. INSPECT WINDSHIELD WIPER MOTOR ASSEMBLY

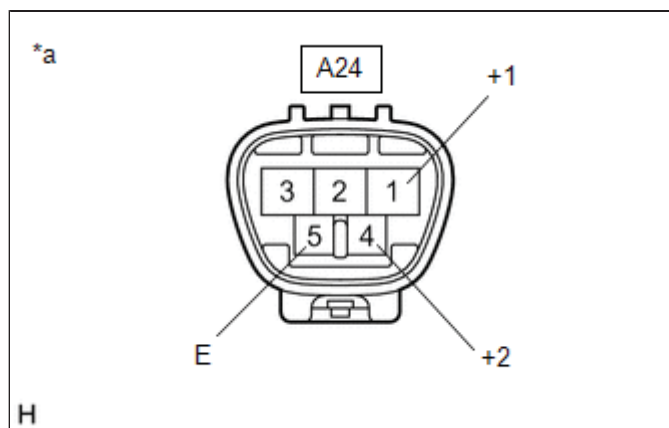

*a	Component without harness connected (Windshield Wiper Motor Assembly)
----	--

(a) Check the LO operation.

OK:



[Click Location & Routing\(A24\)](#)

[Click Connector\(A24\)](#)

TESTER CONNECTION	SPECIFIED CONDITION
A24-1 (+1) - Auxiliary battery positive (+) A24-5 (E) - Auxiliary battery negative (-)	Motor operates at low speed (LO)

(b) Check the HI operation.

OK:



[Click Location & Routing\(A24\)](#)

[Click Connector\(A24\)](#)

TESTER CONNECTION	SPECIFIED CONDITION

A24-4 (+2) - Auxiliary battery positive (+)
A24-5 (E) - Auxiliary battery negative (-)

Motor operates at high speed (HI)

If the result is not as specified, replace the windshield wiper motor assembly.

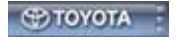

Last Modified: 01-14-2019	6.8:8.0.48	Doc ID: RM100000000S1MG
Model Year Start: 2016	Model: Prius	Prod Date Range: [11/2015 -]
Title: WIPER / WASHER: FRONT WIPER MOTOR: INSTALLATION; 2016 - 2019 MY Prius [11/2015 -]		

INSTALLATION

CAUTION / NOTICE / HINT

NOTICE:

Make sure to hold the front wiper arm while lifting it as lifting the front wiper arm by the front wiper blade may damage or deform the front wiper blade.

PROCEDURE

1. INSTALL WINDSHIELD WIPER MOTOR ASSEMBLY

- (a) Push the windshield wiper motor assembly in the direction indicated by the arrow (1), then move the windshield wiper motor assembly in the direction indicated by the arrow (2) shown in the illustration to temporarily install it to the windshield wiper link assembly.

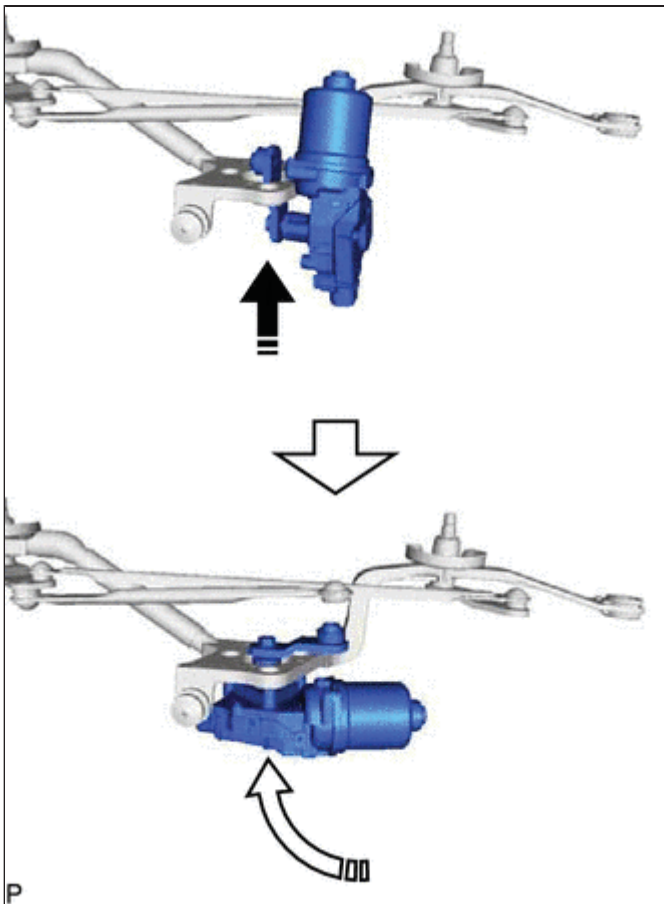

	Install in this Direction (1)
	Install in this Direction (2)

(b) Install the windshield wiper motor assembly with the 3 bolts.

Torque:

5.39 N·m { 55 kgf·cm, 48 in·lbf }

(c) Apply MP grease to the pivot of the windshield wiper motor assembly.

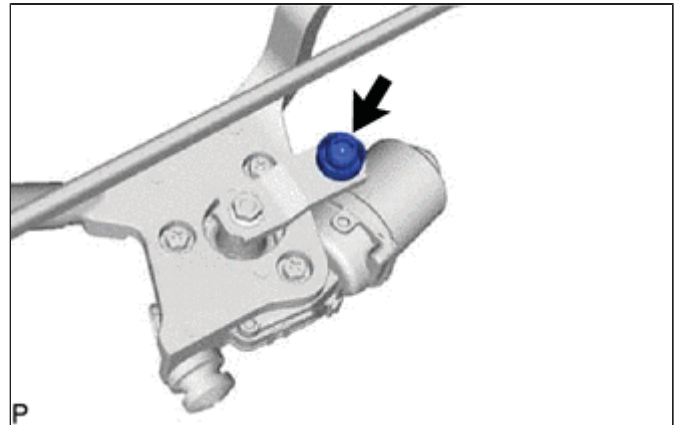

(d) Connect the No. 1 windshield wiper link rod to the pivot of the windshield wiper motor assembly.

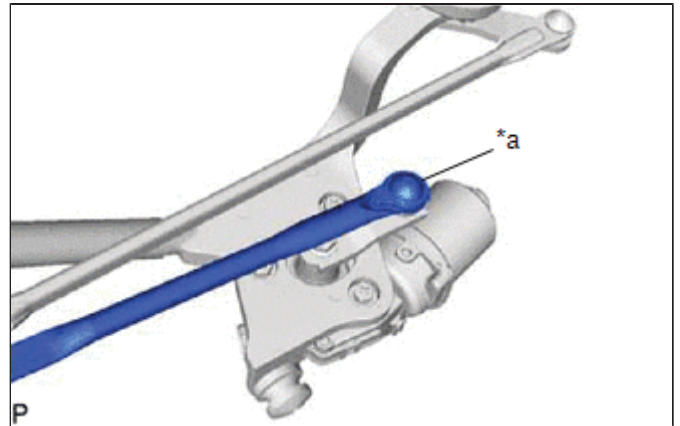

*a	Pivot of Windshield Wiper Motor Assembly
----	--

2. INSTALL WINDSHIELD WIPER MOTOR AND LINK ASSEMBLY

(a) Connect the connector.

(b) Engage the motor grommet as shown in the illustration.

NOTICE:

Be careful not to damage the windshield glass when installing the windshield wiper motor and link assembly.

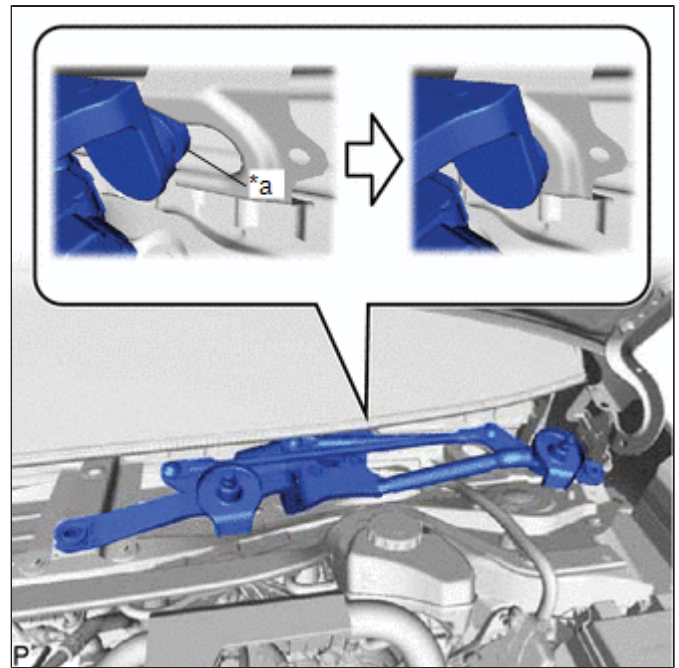

*a	Motor Grommet
----	---------------

(c) Install the windshield wiper motor and link assembly with the 2 bolts.

Torque:

5.5 N·m { 56 kgf·cm, 49 in·lbf }

3. INSTALL COWL TOP VENTILATOR LOUVER SUB-ASSEMBLY

(a) Engage the 4 guides as shown in the illustration.

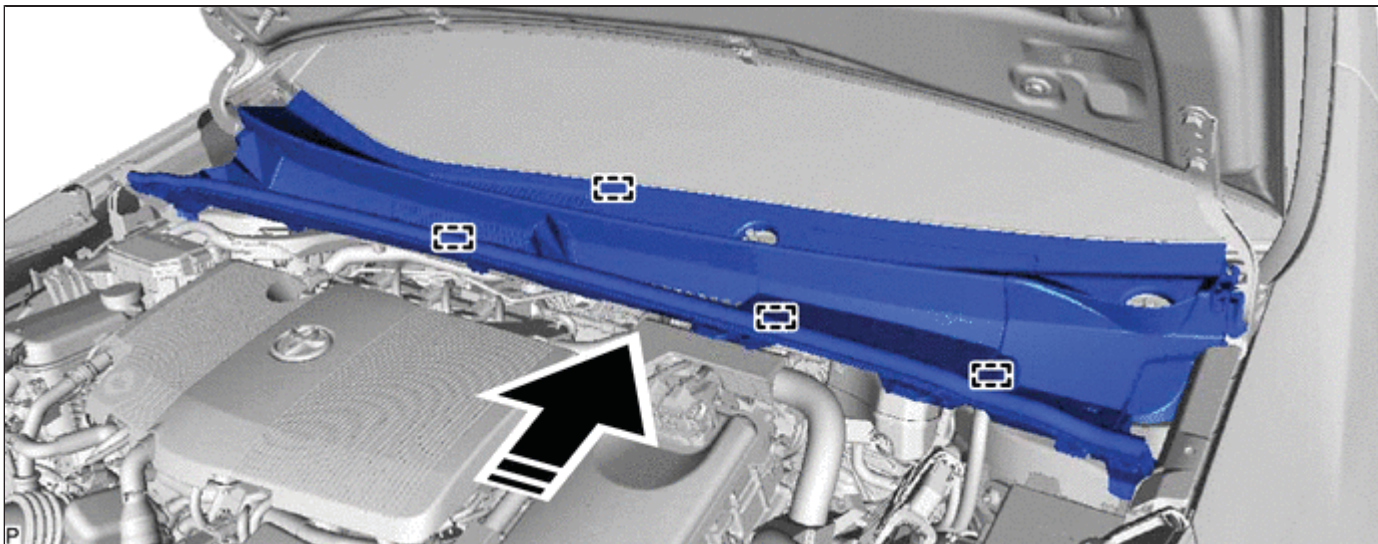

	Install in this Direction	-	-
---	---------------------------	---	---

NOTICE:

- When installing the cowl top ventilator louver sub-assembly, it may contact the brake master cylinder reservoir filler cap assembly and cause it to fall off. Check the installation condition of the brake master cylinder reservoir filler cap assembly after installing the cowl top ventilator louver sub-assembly.

- Make sure to engage the guides securely, otherwise the cowl top ventilator louver sub-assembly may pop up when engaging it to the windshield glass.

(b) Engage the cowl top ventilator louver sub-assembly to the windshield glass as shown in the illustration.

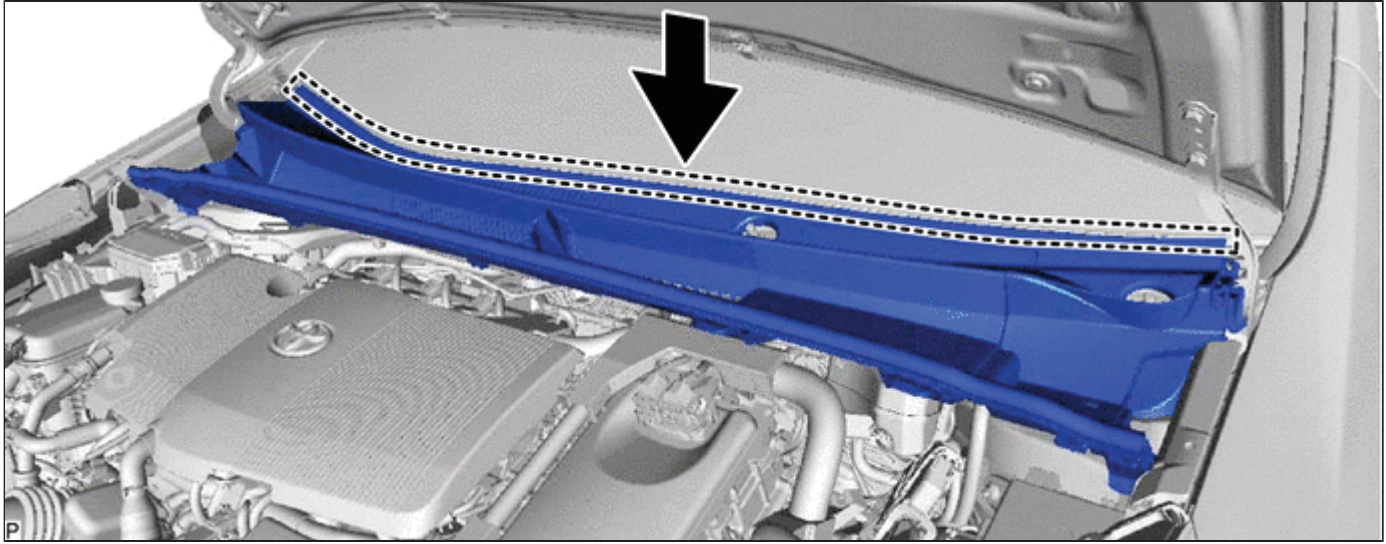

(c) Install the 2 clips.

4. INSTALL COWL WATER EXTRACT SHIELD LH

(a) Temporarily install the cowl water extract shield LH as shown in the illustration.

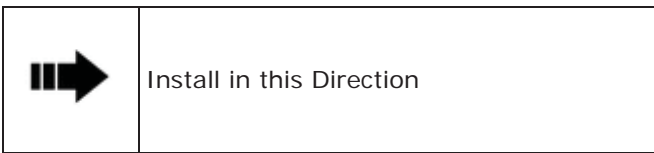
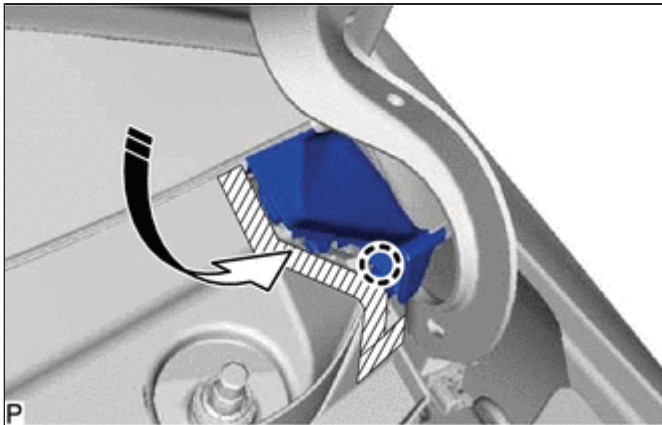

HINT:

Make sure the claw is set at the engagement position.

(b) Engage the cowl water extract shield LH to the windshield glass.

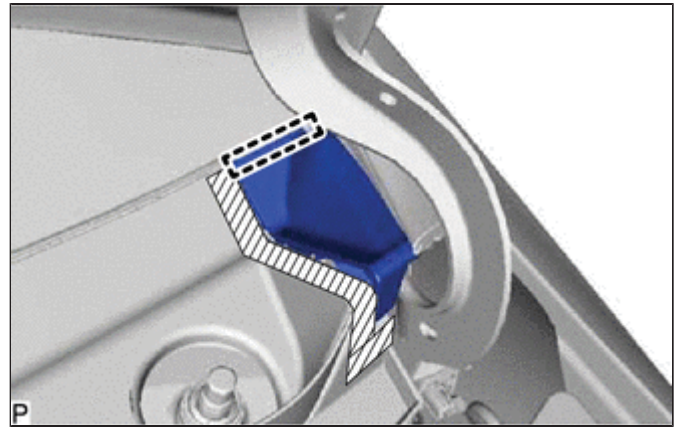

(c) Engage the guide and 2 claws to install the cowl water extract shield LH.

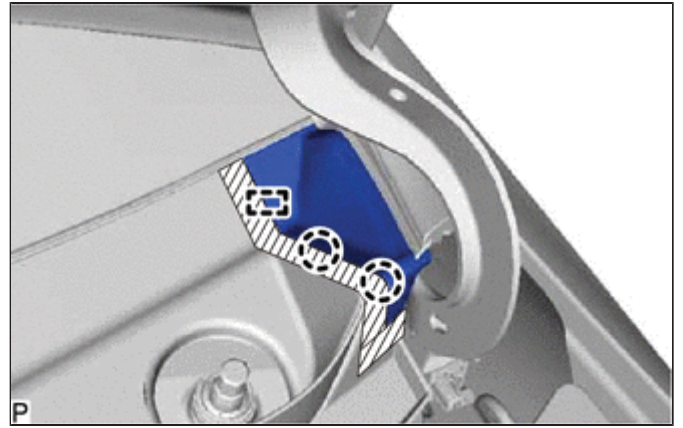

5. INSTALL COWL WATER EXTRACT SHIELD RH

HINT:

Use the same procedure as for the LH side.

6. INSTALL FRONT WIPER ARM AND BLADE ASSEMBLY RH

(a) When reusing the front wiper arm and blade assembly RH:

(1) Clean the wiper arm serrations to remove any burrs, dirt, etc.

NOTICE:

Do not grind down the wiper arm serrations.

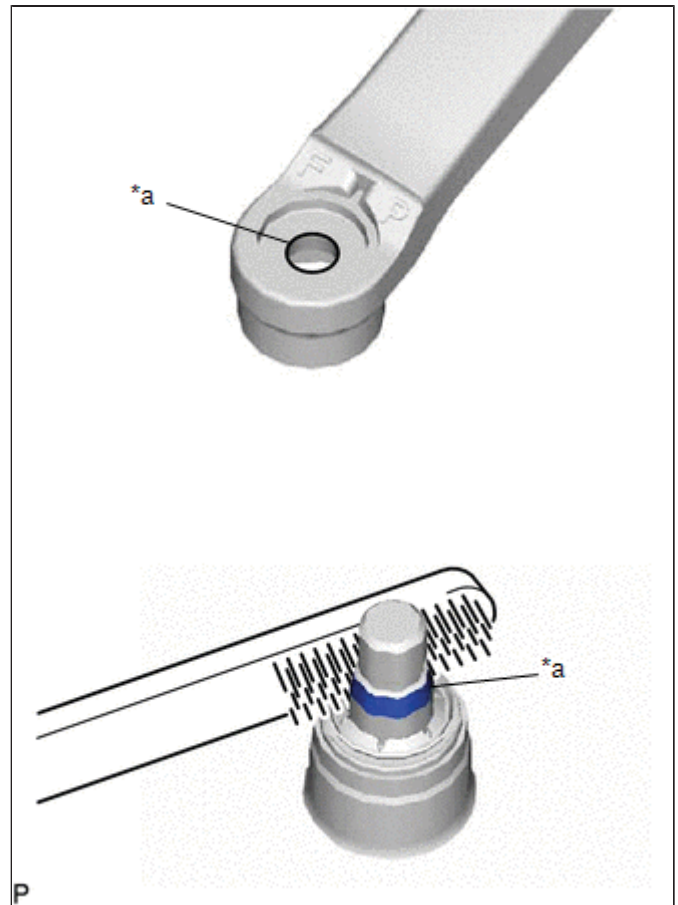

*a	Serration
----	-----------

(b) When reusing the windshield wiper motor and link assembly:

(1) Clean the wiper pivot serrations with a wire brush.

(c) Turn the power switch on (IG).

(d) Operate the windshield wiper motor assembly and stop the windshield wiper motor and link assembly at the automatic stop position.

(e) Turn the power switch off.

(f) Install the front wiper arm and blade assembly RH with the nut to the position shown in the illustration.

Torque:

23 N·m { 235 kgf·cm, 17 ft·lbf }

HINT:

Hold the wiper arm by hand while tightening the nut.

Reference Measurement:

AREA	MEASUREMENT

A	7.5 mm (0.295 in.)

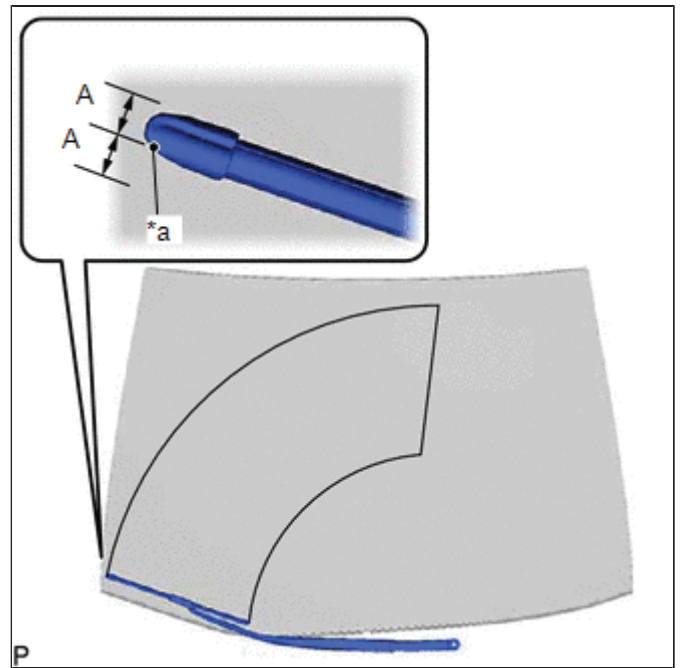

*a	Alignment Mark
----	----------------

7. INSTALL FRONT WIPER ARM AND BLADE ASSEMBLY LH

(a) When reusing the front wiper arm and blade assembly LH:

(1) Clean the wiper arm serrations to remove any burrs, dirt, etc.

NOTICE:

Do not grind down the wiper arm serrations.

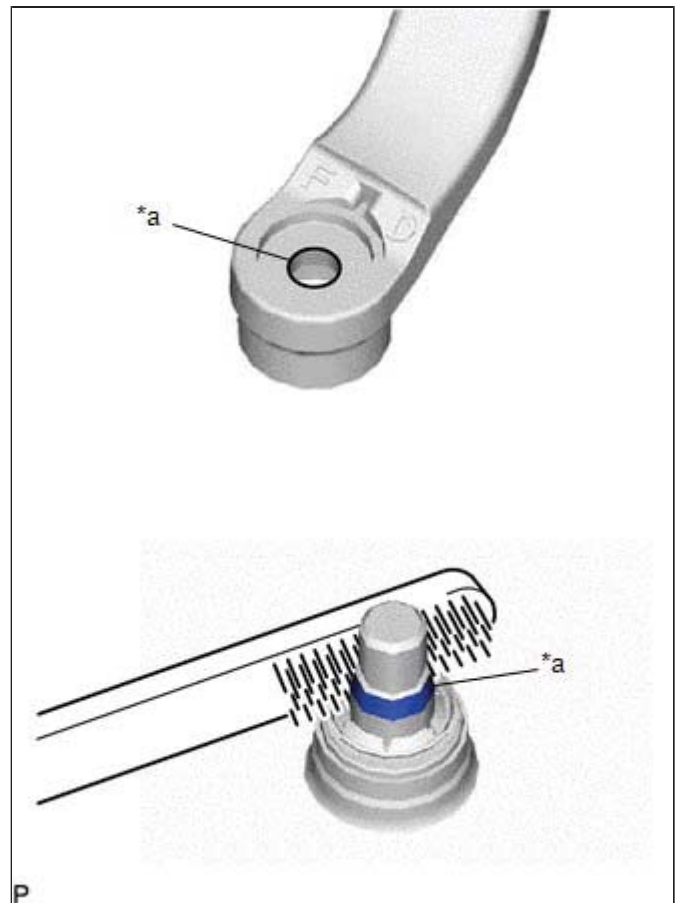

*a	Serration
----	-----------

(b) When reusing the windshield wiper motor and link assembly:

(1) Clean the wiper pivot serrations with a wire brush.

(c) Install the front wiper arm and blade assembly LH with the nut to the position shown in the illustration.

Torque:

23 N·m { 235 kgf·cm, 17 ft·lbf }

HINT:

Hold the wiper arm by hand while tightening the nut.

Reference Measurement:

AREA	MEASUREMENT
A	7.5 mm (0.295 in.)

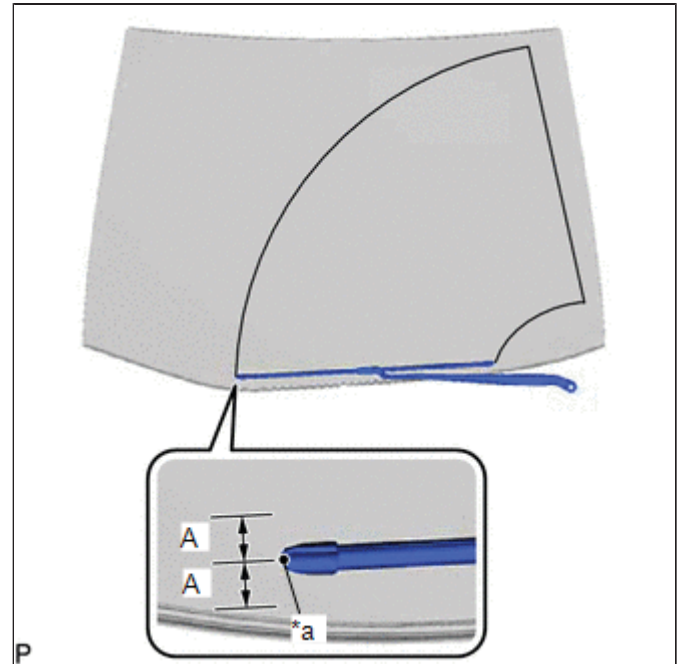

*a	Alignment Mark
----	----------------

(d) Turn the power switch on (IG).

(e) Operate the windshield wipers while spraying washer fluid onto the windshield glass. Make sure that the windshield wipers function properly and the wipers do not contact the vehicle body.

(f) Turn the power switch off.

(g) Lift each wiper arm twice after the wipers stop and check the wiper set position.

8. INSTALL FRONT WIPER ARM HEAD CAP

(a) Engage the 3 claws to install the front wiper arm head cap.

HINT:

Use the same procedure for the RH side and LH side.

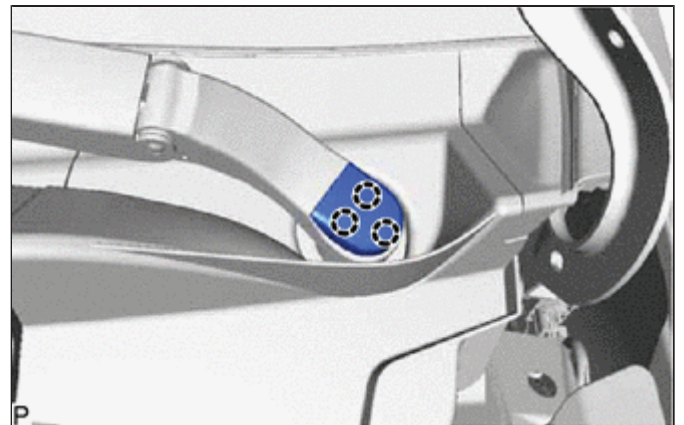

Last Modified: 01-14-2019	6.8:8.0.48	Doc ID: RM100000000TKJL
Model Year Start: 2016	Model: Prius	Prod Date Range: [11/2015 -]
Title: WIPER / WASHER: FRONT WIPER MOTOR: ON-VEHICLE INSPECTION; 2016 - 2019 MY Prius [11/2015 -]		

ON-VEHICLE INSPECTION

PROCEDURE

1. INSPECT WINDSHIELD WIPER MOTOR ASSEMBLY

(a) for LH Side:

(1) Operate the windshield wiper motor assembly.

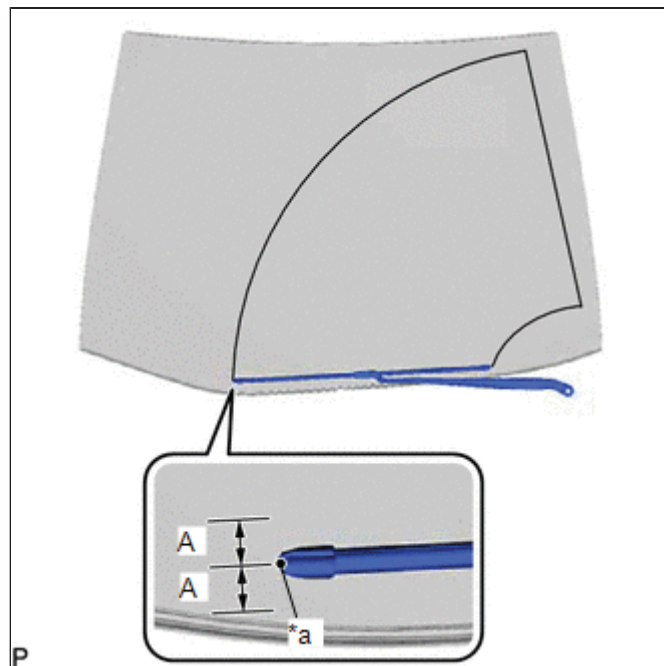

*a	Alignment Mark
----	----------------

(2) Stop the windshield wiper motor assembly operation.

(3) Check the automatic stop (park) position.

HINT:

After the front wiper motor is stopped, check the automatic stop position after lifting the wiper blade 2 times.

Standard Clearance:

AREA	MEASUREMENT
A	7.5 mm (0.295 in.)

OK:

The front wiper stops at the position shown in the illustration.

(b) for RH Side:

(1) Operate the windshield wiper motor assembly.

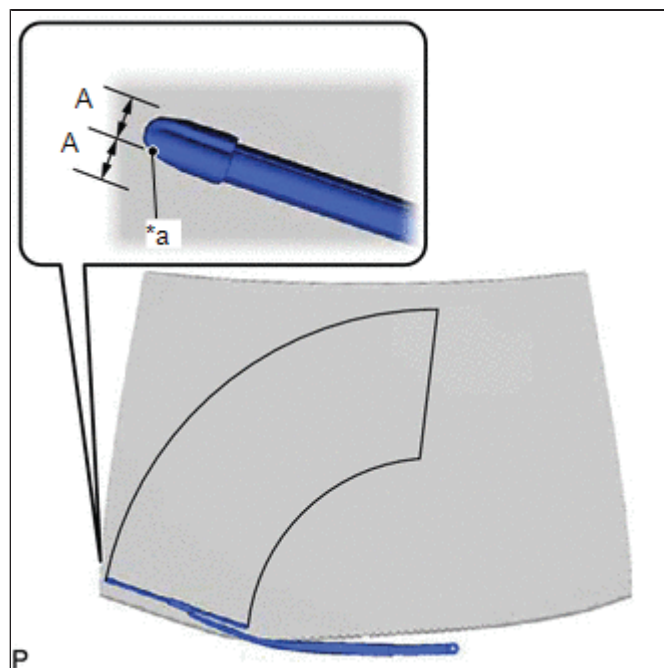

*a	Alignment Mark
----	----------------

(2) Stop the windshield wiper motor assembly operation.

(3) Check the automatic stop (park) position.

HINT:

After the front wiper motor is stopped, check the automatic stop position after lifting the wiper blade 2 times.

Standard Clearance:

AREA	MEASUREMENT
A	7.5 mm (0.295 in.)

OK:

The front wiper stops at the position shown in the illustration.

