

DISASSEMBLY

1. REMOVE NO. 1 VENTILATION CASE

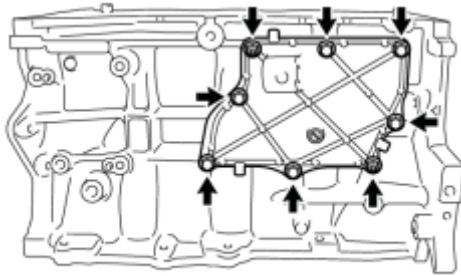

(a) Remove the 6 bolts and 2 nuts.

(b) Remove the ventilation case by prying between the ventilation case and cylinder block with a screwdriver as shown in the illustration.

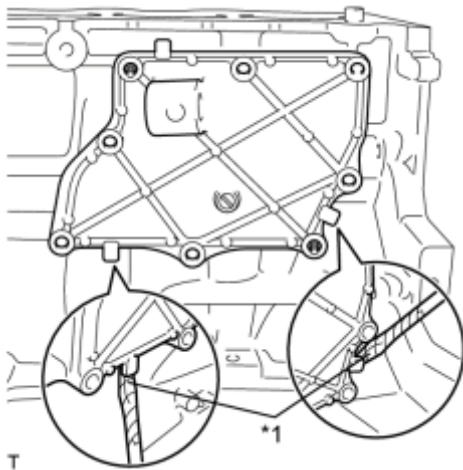

Text in Illustration

*1	Protective Tape
----	-----------------

NOTICE:

Be careful not to damage the contact surfaces of the cylinder block and No. 1 ventilation case.

HINT:

Tape the screwdriver tip before use.

2. INSPECT CONNECTING ROD THRUST CLEARANCE

(a) Using a dial indicator, measure the thrust clearance while moving the connecting rod cap back and forth.

Standard thrust clearance:

0.160 to 0.342 mm (0.00630 to 0.0135 in.)

Maximum thrust clearance:

0.342 mm (0.0132 in.)

If the thrust clearance is greater than the maximum, replace the connecting rod assemblies as necessary. If necessary, replace the crankshaft.

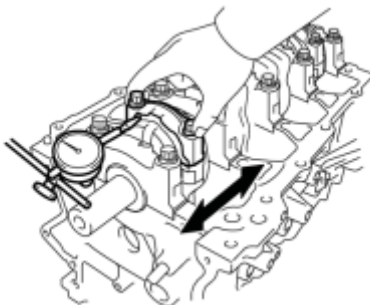

3. INSPECT CONNECTING ROD OIL CLEARANCE

(a) Check that the matchmarks on the connecting rod and cap are aligned

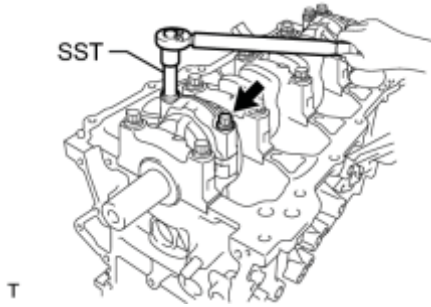

(1) Using SST, install and alternately tighten the bolts of the connecting rod cap in several steps.

SST: 09205-16011

Torque: **20 N·m (204 kgf·cm, 15ft·lbf)**

(h) Step 2:

(1) Mark the front of the connecting rod cap bolts with paint.

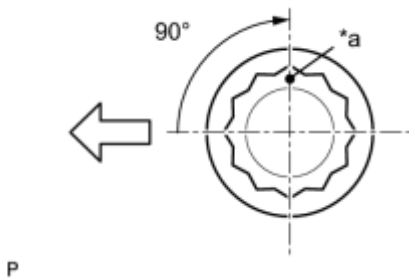

Text in Illustration

*a	Paint Mark
➔	Engine Front

(2) Tighten the cap bolts 90° as shown in the illustration.

(i) Check that the crankshaft turns smoothly.

(j) Check the connecting rod thrust clearance INFO.

10. INSTALL NO. 1 VENTILATION CASE

(a) Apply seal packing in a continuous line as shown in the illustration.

Text in Illustration

*a	Seal Packing
*b	Seal Packing Diameter

Seal packing:

Toyota Genuine Seal Packing Black, Three Bond 1207B or equivalent

Application Specification:

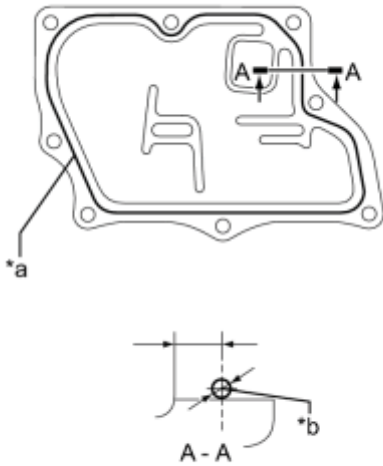

Seal Packing Diameter	Distance from inside edge of cover to center of seal packing
2.0 to 3.0 mm (0.0787 to 0.118 in.)	3.0 mm (0.118 in.)

- Remove any oil from the contact surface.
- Install the ventilation case within 3 minutes and tighten the bolts and nuts within 15 minutes of applying seal packing.
- Do not start the engine for at least 2 hours after installation.

T

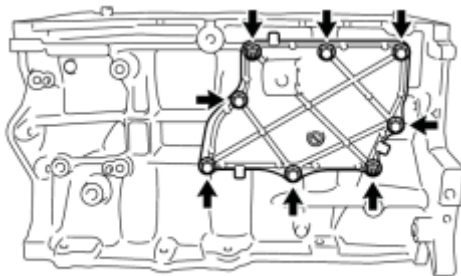

(b) Install the ventilation case with the 6 bolts and 2 nuts.

Torque: 10 N·m (102 kgf·cm, 7ft·lbf)

T