

and the center of the cylinder head gasket tab is within 4 mm (0.157 in.).

c

#### 45. INSTALL CYLINDER HEAD COVER SUB-ASSEMBLY

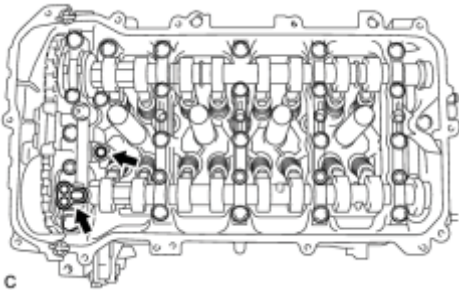

(a) Install 2 new gaskets to the camshaft bearing cap.

c

(b) Apply seal packing as shown the illustration.

Seal packing:

Toyota Genuine Seal Packing Black, Three Bond 1207B or equivalent

Standard diameter:

4.0 mm (0.157 in.)

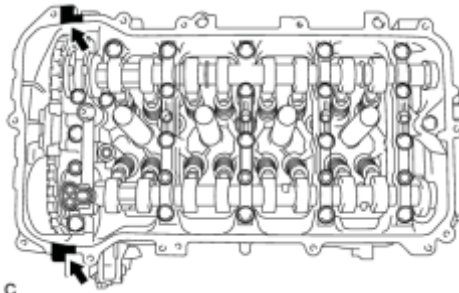

c

- Remove any oil from the contact surfaces.
- Install the cylinder head cover sub-assembly within 3 minutes and tighten the bolts within 15 minutes of applying seal packing.
- Do not start the engine for at least 2 hours after the installation.

(c) Install the cylinder head cover with a new seal washer and the 13 bolts.

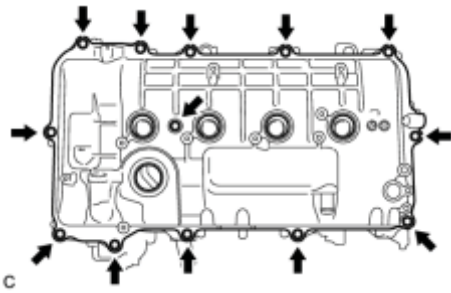

Torque: 10 N·m (102 kgf·cm, 7ft·lbf)

**NOTICE:**

Misalignment between the contact surfaces of the timing chain cover and the camshaft housing and the center of the cylinder head gasket tab is within 4 mm (0.157 in.).

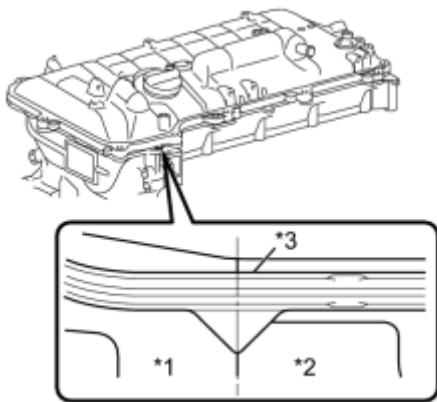

**Text in Illustration**

*1	Timing Chain Cover
*2	Camshaft Housing
*3	Cylinder Head Cover Gasket

**46. INSTALL ENGINE OIL PRESSURE SWITCH ASSEMBLY**

(a) Apply adhesive to 2 or 3 threads of the engine oil pressure switch assembly.

**Text in Illustration**

*1	Adhesive
----	----------