

INSTALLATION

1. INSTALL REAR ENGINE OIL SEAL

(a) Apply MP grease to the lip of a new oil seal.

NOTICE:

Keep the lip free from foreign matter.

(b) Using SST and a hammer, tap in the oil seal until its surface is flush with the rear oil seal retainer edge.

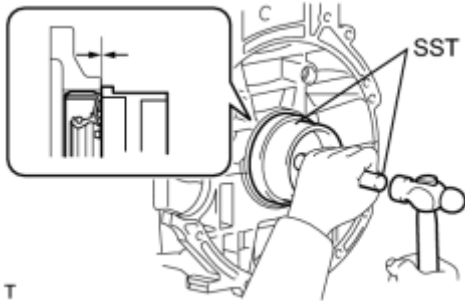

SST: 09223-15030

SST: 09950-70010

09951-07100

- Wipe any extra grease off the crankshaft.
- Do not tap the oil seal at an angle.

2. INSTALL FLYWHEEL SUB-ASSEMBLY

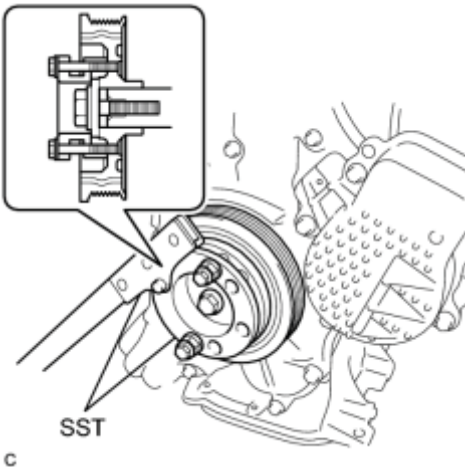

(a) Using SST, hold the crankshaft.

SST: 09213-58014

91551-80840

SST: 09330-00021

(b) Apply adhesive to the 2 or 3 end threads of the bolts.

Text in Illustration

*1	Adhesive
----	----------

Adhesive:

Toyota Genuine Adhesive 1324, Three Bond 1324 or equivalent

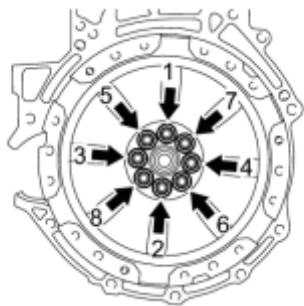

(c) Using several steps, uniformly install and tighten the 8 bolts in the sequence shown in the illustration.

Torque: **49 N·m (500 kgf·cm, 36ft·lbf)**

c

(d) Mark the front of the bolts with paint.

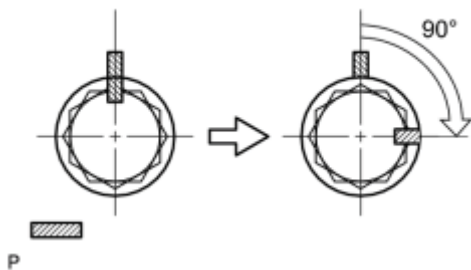

Text in Illustration

	Paint Mark
---	------------

(e) Retighten the 8 bolts 90° in the same sequence.

(f) Check that the paint marks are now at a 90° angle to the front.

(g) Check that the crankshaft turns smoothly.

3. INSTALL TRANSMISSION INPUT DAMPER ASSEMBLY

(a) Using SST, hold the crankshaft.

SST: 09213-58014

91551-80840

SST: 09330-00021

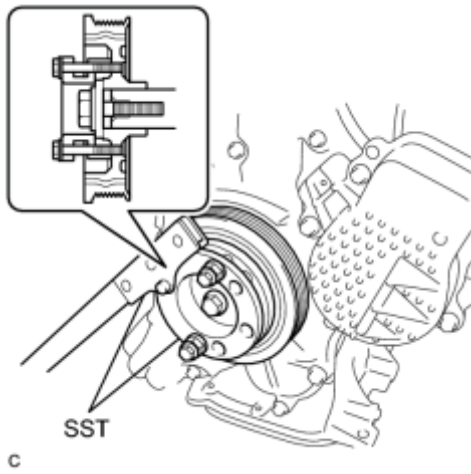

(b) Install the transmission input damper.

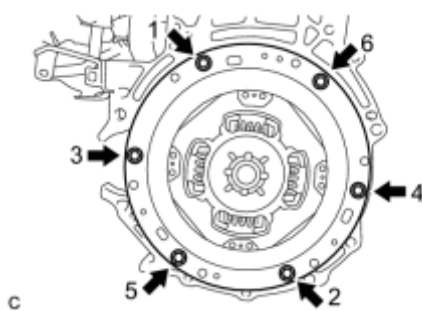

(c) In several steps, uniformly install and tighten the 6 bolts in the sequence shown in the illustration.

Torque: **30 N·m (306 kgf·cm, 22ft·lbf)**

NOTICE:

Take care not to insert the transmission input damper in a wrong direction.

4. INSTALL HYBRID VEHICLE TRANSAXLE ASSEMBLY

(a) Install the hybrid vehicle transaxle assembly INFO.

NOTICE:

Be careful not to apply excess force to the transmission input damper assembly when removing or installing the hybrid vehicle transaxle assembly. If excess force is applied, the transmission input damper assembly may be damaged, or its splines may become misaligned.