



# INSTALLATION INSTRUCTIONS FOR PART 99-8213

## APPLICATIONS

# Toyota Prius 2004-2007

# 99-8213



### KIT FEATURES

- ISO DIN Head Unit Provisions with Pocket

### KIT COMPONENTS

A) Radio Housing w/ Pocket | B) Trim Plate | C) Pocket | D) (2) Phillips Screws

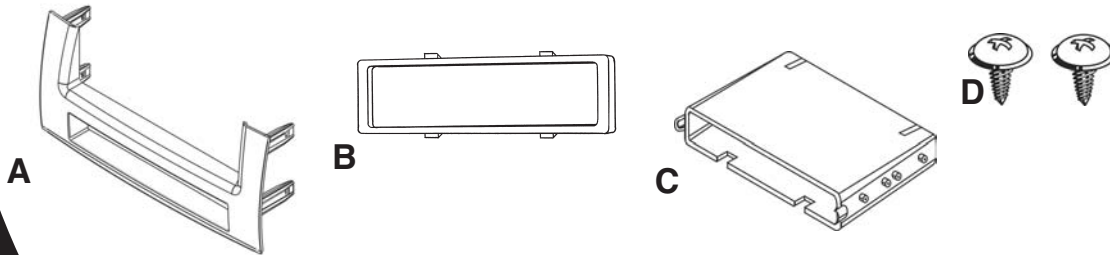

### TOOLS REQUIRED:

Socket Wrench | Flat Blade Screwdriver | Phillips Screwdriver | Utility Knife | Tape or Heat Shrink

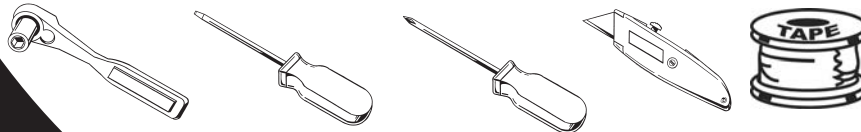

1-800-221-0932



[www.metraonline.com](http://www.metraonline.com)

© COPYRIGHT 2004-07 METRA ELECTRONICS CORPORATION



# 99-8213

## TABLE OF CONTENTS

<i>Dash Disassembly</i> .....	1-2
<i>Kit Assembly</i> .....	3
<i>Climate Control Wiring</i> .....	4
<i>Final Assembly</i> .....	5

## 2004-2007 TOYOTA PRIUS

# DASH DISASSEMBLY

- 1 Disconnect the negative battery terminal to prevent an accidental short circuit.
- 2 Unsnap panel with vent on driver's side and remove. (Figure A)
- 3 Remove (2) Phillips screws on panel below steering column with hood release on it and remove panel. (Figure A)
- 4 Unclip and remove panel surrounding under side of steering column.. (Figure B)
- 5 Unclip and remove panel above steering column. (Figure C)
- 6 Unclip and remove vent panel surrounding the shifter. (Figure D)
- 7 Open glove box and remove vent panel next to the radio. (Figure D)

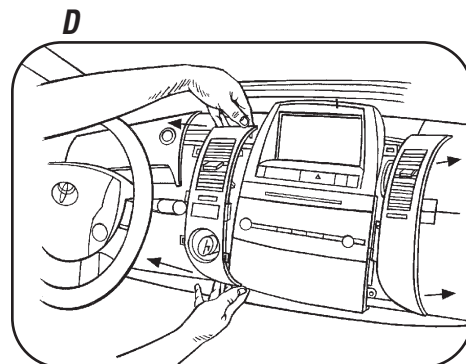
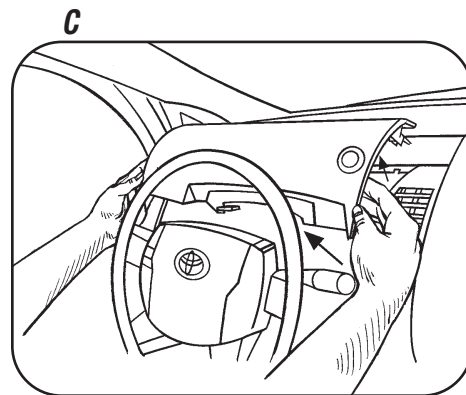
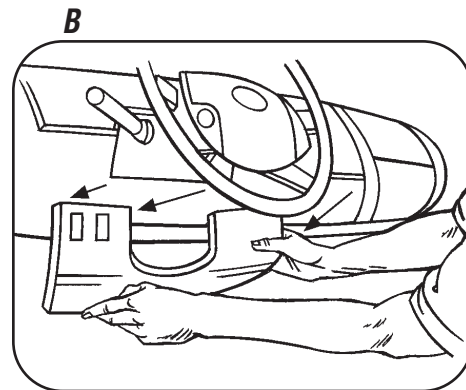
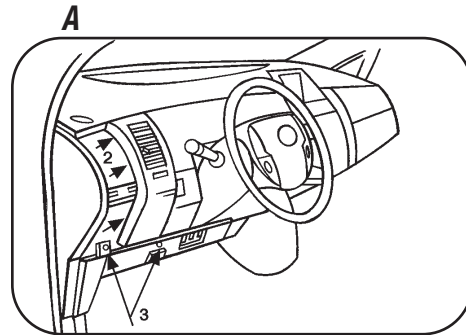

### 2004-2007 TOYOTA PRIUS (CON'T)

- 8 Remove (2) Phillips screws from flip open panel below radio, unclip and remove. (Figure E)
- 9 Remove (2) 10mm bolts from info center display above radio, unclip and remove. (Figure F)
- 10 Remove (2) 10mm bolts from top of radio assembly. (Figure G)
- 11 Remove (2) 10mm bolts from bottom of radio assembly, unclip radio and remove. (Figure G)
- 12 Remove (4) Phillips screws to remove factory radio from bracket assembly. Note position of factory radio in bracket assembly for reference in step 1 of Kit Assembly. (Figure H)

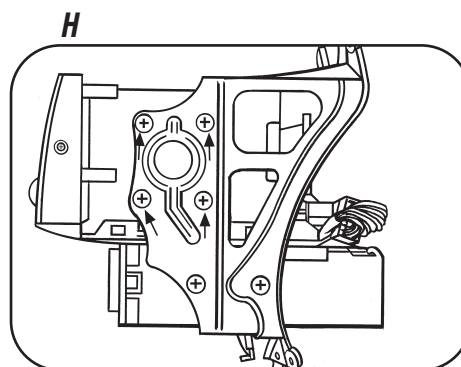
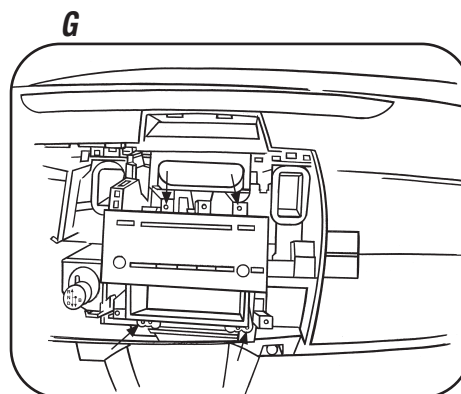
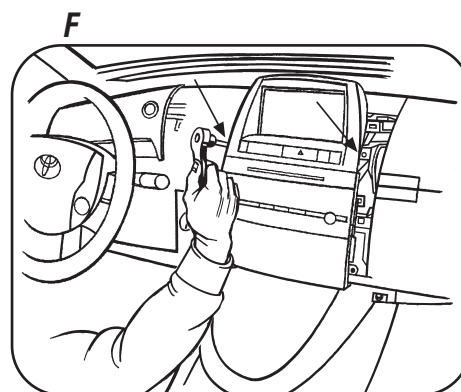
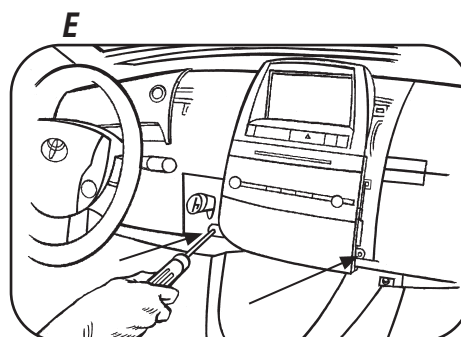

## ISO DIN HEAD UNIT PROVISIONS

- 1 For the pocket to fit properly inside the dash the sides of the pocket need to be trimmed. (Figure A)
- 2 Using a utility knife carefully cut off the 4 round pieces on each side of the pocket. (Figure A)
- 3 Attach the pocket to the back of the trim plate using the Phillips Screws supplied with the kit. (Figure B)
- 4 Position aftermarket head unit into factory audio bracket assembly and secure using the top (2) screw positions and the hardware supplied with the new head unit. (Figure C)

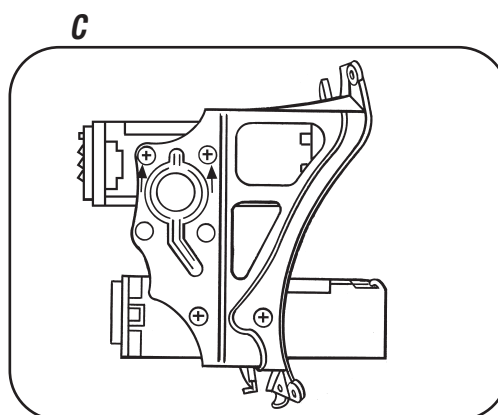
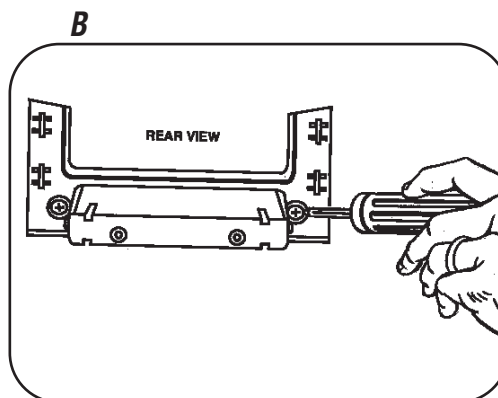
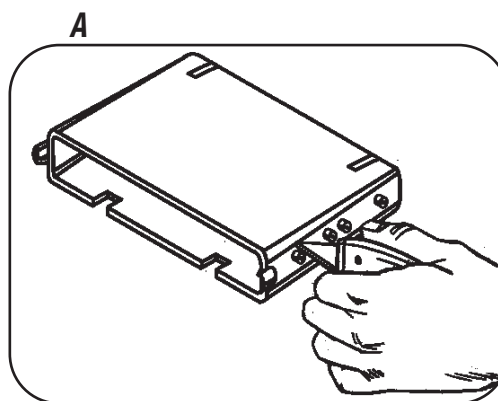

**KIT ASSEMBLY**

## CLIMATE CONTROL WIRING

For the climate controls to operate properly, the following steps need to be followed:

- 1 Locate the 20 way white connector that has 5 wires in it that was plugged into the factory radio. (see diagram)
- 2 You will need the small gauge white wire in pin 10 and the small gauge pink wire in pin 9. The 3 remaining larger gauge wires are not needed at this time. (see diagram)
- 3 Strip back the white and pink wires, connect one side of the 68 OHM resistor to the white wire and connect the other side of the resistor to the pink wire (see diagram).
- 4 When completed be sure to tape up the wires including the resistor to protect them from coming into contact with any metal, and push the 20 way connector back into the dash. (see diagram)

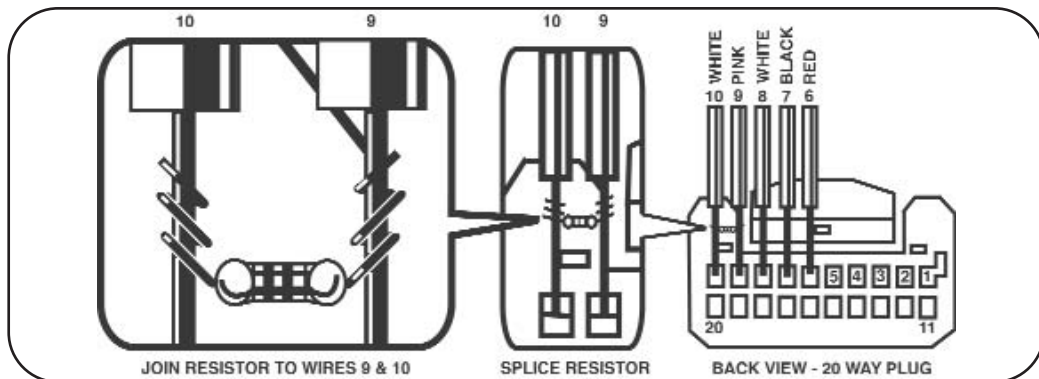

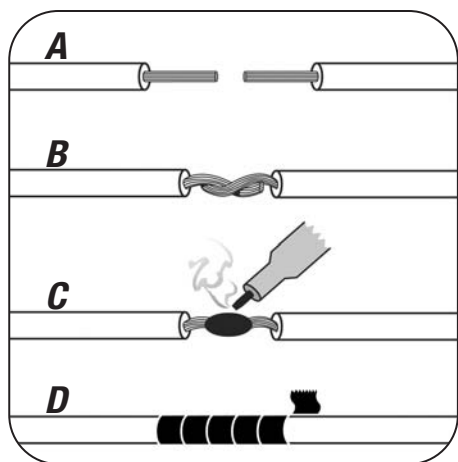

- A) Strip wire ends back 1/2"*
- B) Twist ends together*
- C) Solder*
- D) Tape*

- 1** Locate the factory wiring harness in the dash. Metra recommends using the proper mating adapter and making the connections as shown. (Isolate and individually tape off the ends of any unused wires to prevent electrical short circuit)
  
- 2** Re-connect the negative battery terminal and test the unit for proper operation.
  
- 3** Reassemble radio and dash assemblies in reverse order of disassembly using the 99-8213 in place of the factory panel.

**FINAL ASSEMBLY**

**INST99-8213**



**1-800-221-0932**



**[www.metraonline.com](http://www.metraonline.com)**

Rev. 06-20-07

© COPYRIGHT 2004-07 METRA ELECTRONICS CORPORATION

INST99-8213