

**[N\*m (kgf\*cm, ft.\*lbf)]** : Specified torque

● Non-reusable part

← Lithium soap base glycol grease

c

# REMOVAL

## 1. DISABLE BRAKE CONTROL

(a) Wait at least 2 minutes after the power switch off.

### NOTICE:

When the brake pedal is depressed or the door courtesy switch is turned on even if the power switch is off, the brake control system activates. Therefore do not depress the brake pedal or open/close the doors until the reservoir level switch connector is disconnected.

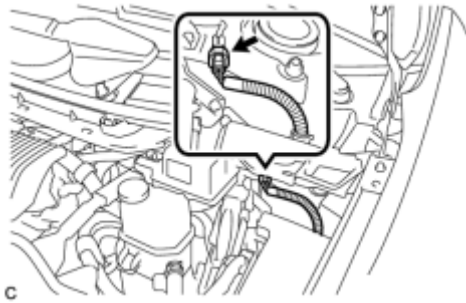

(b) Disconnect the reservoir level switch connector.

(c) Connect the Techstream to the DLC3 and turn the power switch on (IG).

(d) Turn the Techstream on and enter the following menu: Chassis / ABS/VSC/TRC / Active Test.

(e) Select "ECB (Electronically Controlled Brake system) Control Invalid".

(f) Depress the brake pedal 40 times or more to return the all fluid in the accumulator back to the reservoir.

### NOTICE:

A drop in accumulator pressure may cause a buzzer to sound. This is not a malfunction, therefore continue with the operation.

(g) Check that the brake pedal can not be further depressed.

(h) Select "NEXT" to finish "ECB (Electronically Controlled Brake system) Invalid".

(i) Turn the power switch off and turn the Techstream off.

2. REMOVE REAR NO. 2 FLOOR BOARD (for Separate Type) INFO

3. REMOVE REAR DECK FLOOR BOX INFO

4. REMOVE REAR NO. 3 FLOOR BOARD INFO

5. DISCONNECT CABLE FROM NEGATIVE BATTERY TERMINAL

NOTICE:

When disconnecting the cable, some systems need to be initialized after the cable is reconnected INFO.

6. REMOVE NO. 1 INSTRUMENT PANEL UNDER COVER SUB-ASSEMBLY INFO

7. REMOVE WINDSHIELD WIPER MOTOR AND LINK ASSEMBLY

HINT:

Refer to the procedure up to Remove Windshield Wiper Motor And Link Assembly INFO.

8. REMOVE COWL BODY MOUNTING REINFORCEMENT LH

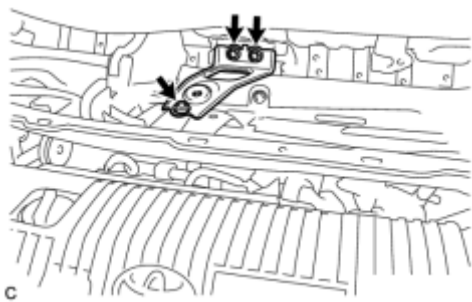

(a) Remove the 3 bolts and cowl body mounting reinforcement LH.

9. REMOVE OUTER COWL TOP PANEL SUB-ASSEMBLY

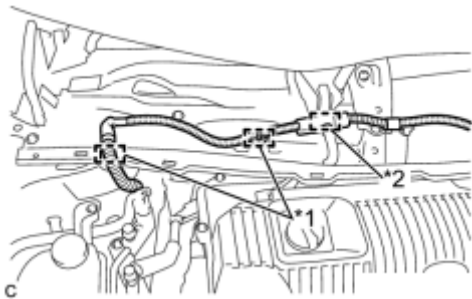

(a) Disengage the 2 clamps and guide of the wire harness.

**Text in Illustration**

*1	Clamp
*2	Guide



(b) Disengage the claw and bend the No. 1 heater air duct splash shield seal.

(c) Disengage the claw and bend the water guard plate RH.

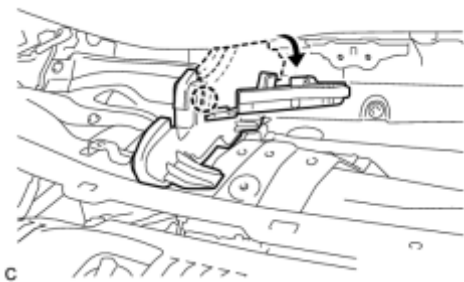

c

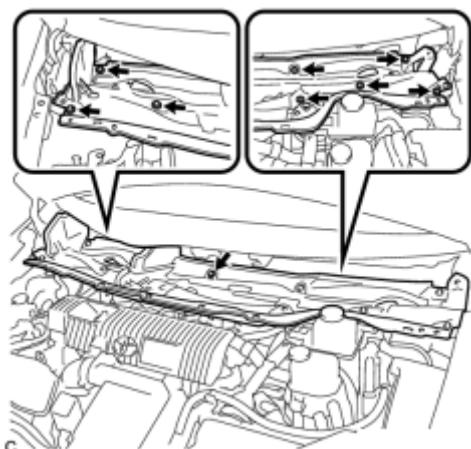

c

(d) Remove the 9 bolts and outer cowl top panel sub-assembly.

## 10. DRAIN BRAKE FLUID

### NOTICE:

If brake fluid leaks onto any painted surface, immediately wash it off.

## 11. REMOVE BRAKE PEDAL RETURN SPRING INFO

## 12. REMOVE PUSH ROD PIN INFO

## 13. SEPARATE BRAKE MASTER CYLINDER RESERVOIR WITH BRACKET

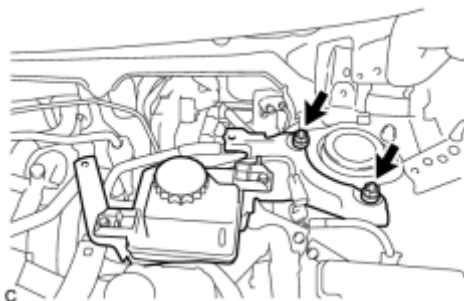

c

(a) Remove the 2 nuts and separate the brake master cylinder reservoir with bracket.

## 14. DISCONNECT NO. 1 RESERVOIR HOSE

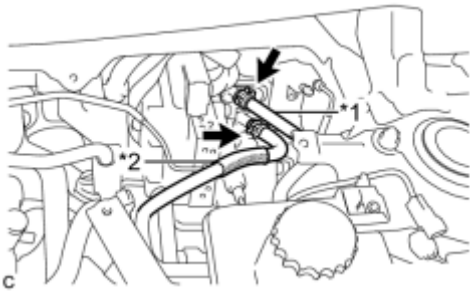

(a) Move the 2 clips and disconnect the No. 1 reservoir hose and No. 2 reservoir hose from the brake booster with master cylinder assembly.

### Text in Illustration

*1	No. 1 Reservoir Hose
*2	No. 2 Reservoir Hose

15. DISCONNECT NO. 2 RESERVOIR HOSE

16. DISCONNECT BRAKE ACTUATOR HOSE

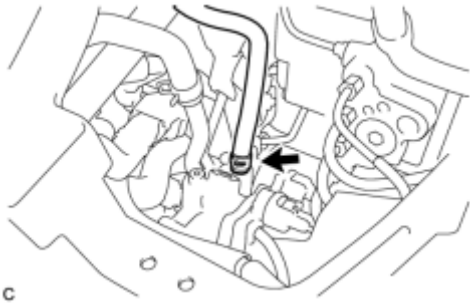

(a) Move the clip and disconnect the brake actuator hose from the brake booster pump assembly.

17. REMOVE BRAKE MASTER CYLINDER RESERVOIR WITH BRACKET

18. REMOVE NO. 5 BRAKE ACTUATOR BRACKET

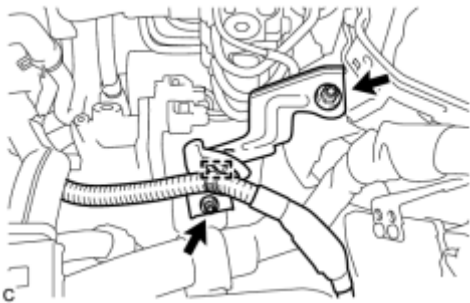

(a) Disengage the clamp.

(b) Remove the 2 nuts and No. 5 brake actuator bracket.

19. REMOVE BRAKE BOOSTER WITH MASTER CYLINDER ASSEMBLY

(a) Release the lock lever and disconnect the connector.

NOTICE:

Be careful not to allow the brake fluid to enter the removed connector.

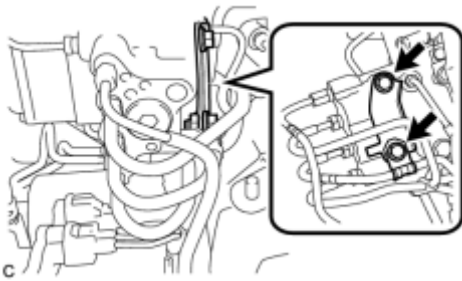
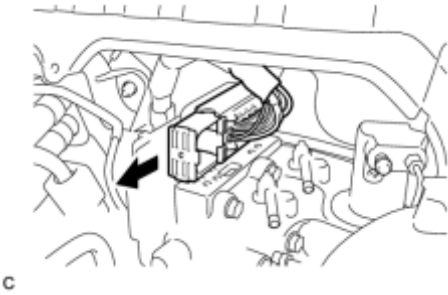

(b) Remove the 2 bolts and No. 2 brake tube clamp bracket from the brake booster with master cylinder assembly.

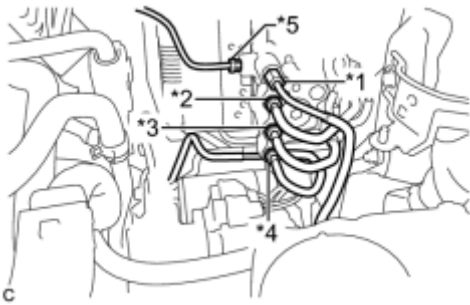

(c) Using a union nut wrench, disconnect the 5 brake lines from the brake booster with master cylinder assembly.

(d) Use tags or make a memo to identify the places to reconnect.

**Text in Illustration**

*1	to Front Wheel Cylinder LH
*2	to Rear Wheel Cylinder RH
*3	to Brake Booster Pump Assembly
*4	to Rear Wheel Cylinder LH
*5	to Front Wheel Cylinder RH

(e) Disengage the 2 clamps and separate the brake line.

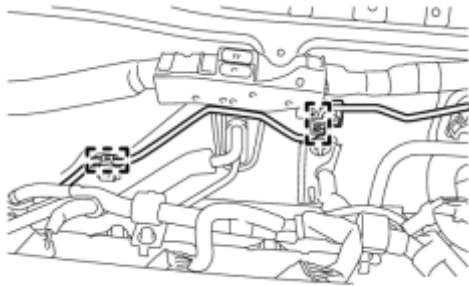

c

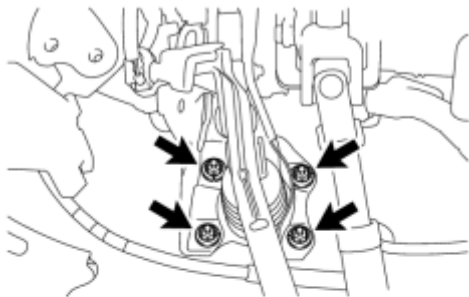

(f) Remove the 4 nuts and brake booster with master cylinder assembly.

### Text in Illustration

*1	Connector Portion
*2	Union
*3	Push Rod Clevis and Boot
*4	Front No. 2 Brake Tube

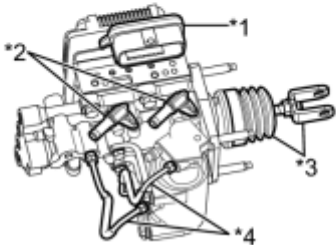

c

- Do not kink or damage the brake lines.
- Do not carry the brake booster with master cylinder assembly by the portion shown in the illustration.

## 20. REMOVE BRAKE BOOSTER GASKET

# INSTALLATION

## 1. INSTALL BRAKE BOOSTER GASKET

(a) Install a new brake booster gasket to the brake booster with master cylinder assembly.

## 2. INSTALL BRAKE BOOSTER WITH MASTER CYLINDER ASSEMBLY

(a) Install the brake booster with master cylinder assembly with the 4 nuts.

### Text in Illustration

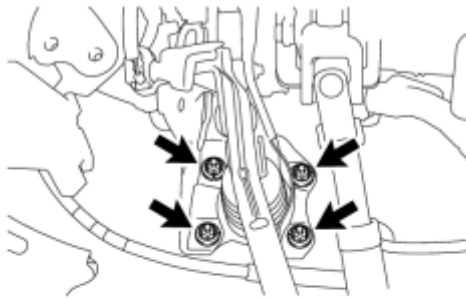

*1	Connector Portion
*2	Union
*3	Push Rod Clevis and Boot
*4	Front No. 2 Brake Tube

Torque: **13 N·m (130 kgf·cm, 9ft·lbf)**

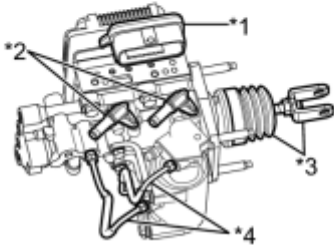

c

- Do not kink or damage the brake lines.
- Do not carry the brake booster with master cylinder assembly by the portion shown in the illustration.
- Be careful not to allow brake fluid to enter the connector of ECU.
- If installing a new brake booster with master cylinder assembly, do not remove the hole plugs before connecting the brake lines because the brake booster with master cylinder is filled with brake fluid.

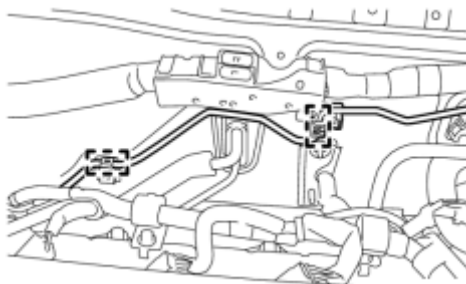

c

(b) Engage the 2 clamps to install the brake line.

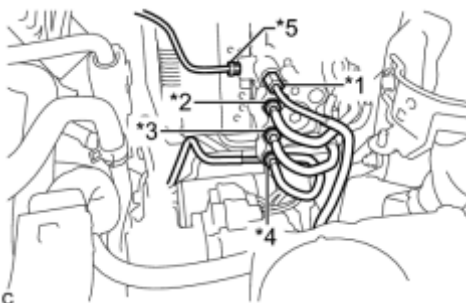

c

(c) Temporarily tighten each brake line to the correct position on the brake booster with master cylinder assembly as shown in the illustration.

### Text in Illustration

*1	to Front Wheel Cylinder LH
*2	to Rear Wheel Cylinder RH
*3	to Brake Booster Pump Assembly



*4	to Rear Wheel Cylinder LH
*5	to Front Wheel Cylinder RH

(d) Install the No. 2 brake tube clamp bracket to the brake booster with master cylinder assembly with the 2 bolts.

## Text in Illustration

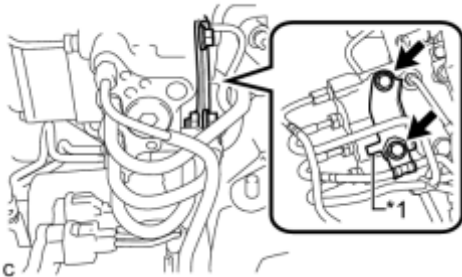

*1	Stopper
----	---------

Torque: **7.0 N·m (71 kgf·cm, 62in·lbf)**

NOTICE:

Securely install the No. 2 brake tube clamp bracket so that its stopper contacts the brake booster with master cylinder assembly as shown in the illustration.

(e) Using a union nut wrench, fully tighten each brake line.

Torque: **15 N·m (155 kgf·cm, 11ft·lbf)**

NOTICE:

- Do not kink or damage the brake lines.
- Use the formula to calculate special torque values for situations where the union nut wrench is combined with a torque wrench INFO.

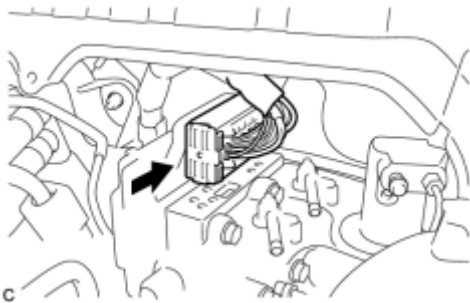

(f) Connect the connector.

- Make sure that the connector can be connected smoothly. Do not allow water, oil or dirt to enter.
- Make sure that the connector lock is locked securely.

### 3. INSTALL NO. 5 BRAKE ACTUATOR BRACKET

(a) Install the No. 5 brake actuator bracket with the 2 nuts.

Torque: **8.5 N·m (87 kgf·cm, 75in·lbf)**

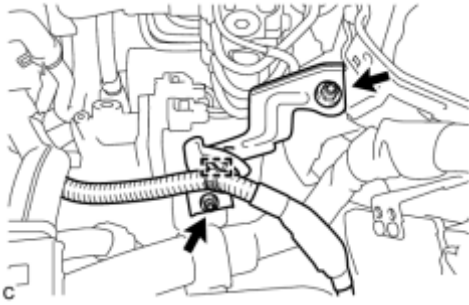

(b) Engage the clamp.

#### 4. CONNECT BRAKE ACTUATOR HOSE

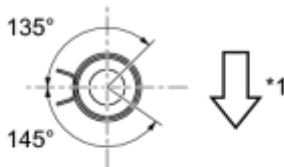

(a) Connect the brake actuator hose to the brake booster pump assembly with the clip.

### Text in Illustration

*1	Front of Vehicle
----	------------------

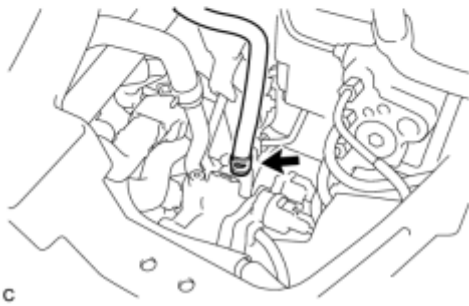

- Make sure to match the identification mark (yellowish green) on the hose with the brake booster pump rib.
- Make sure to install the hose to the proper location.
- Install the clip within the range shown in the illustration.

#### 5. CONNECT NO. 1 RESERVOIR HOSE

(a) Connect the No. 1 reservoir hose and No. 2 reservoir hose to the brake booster with master cylinder assembly with the 2 clips.

### Text in Illustration

*1	No. 1 Reservoir Hose
*2	No. 2 Reservoir Hose
*3	Top of Vehicle

- Make sure to match the identification marks on the hoses and brake booster with master cylinder assembly.

	<b>Hose Identification</b>	<b>Brake Booster with Mas</b>
--	----------------------------	-------------------------------

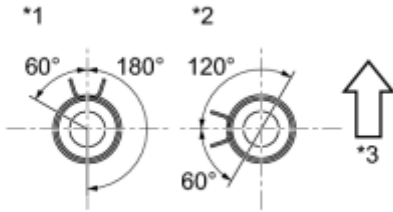

	Mark Color	Cylinder Assembly Identification Mark Color
No. 1 Reservoir Hose	White	White (Unpainted Color)
No. 2 Reservoir Hose	Green	Green

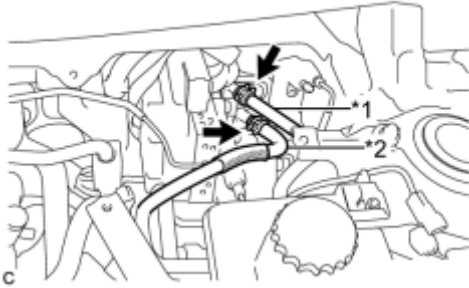

- When connecting the reservoir hose, face the identification mark to the top of the vehicle.
- Make sure to install the hose to the proper location.
- Install the clip within the range shown in the illustration.

6. CONNECT NO. 2 RESERVOIR HOSE

7. INSTALL BRAKE MASTER CYLINDER RESERVOIR WITH BRACKET

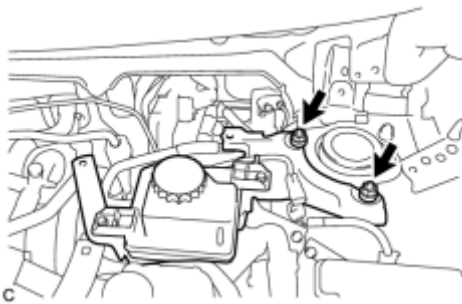

(a) Install the brake master cylinder reservoir with bracket with the 2 nuts.

Torque: **50 N·m (510 kgf·cm, 37ft·lbf)**

8. INSTALL PUSH ROD PIN INFO

9. INSTALL BRAKE PEDAL RETURN SPRING INFO

10. CONNECT CABLE TO NEGATIVE BATTERY TERMINAL

NOTICE:

When disconnecting the cable, some systems need to be initialized after the cable is reconnected INFO.

11. BLEED BRAKE SYSTEM INFO

12. INSPECT AND ADJUST BRAKE PEDAL

HINT: INFO

13. OBTAIN ZERO POINT OF YAW RATE AND ACCELERATION SENSOR

HINT:

After the brake booster with master cylinder assembly is replaced, obtain the zero point of the yaw rate and acceleration sensor INFO.

14. INSTALL NO. 1 INSTRUMENT PANEL UNDER COVER SUB-ASSEMBLY INFO

15. INSTALL OUTER COWL TOP PANEL SUB-ASSEMBLY



(a) Install the outer cowl top panel sub-assembly with the 9 bolts.

Torque: **12 N·m (122 kgf·cm, 9ft·lbf)**

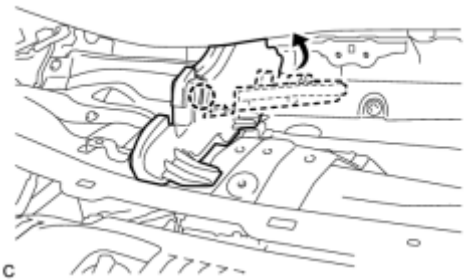
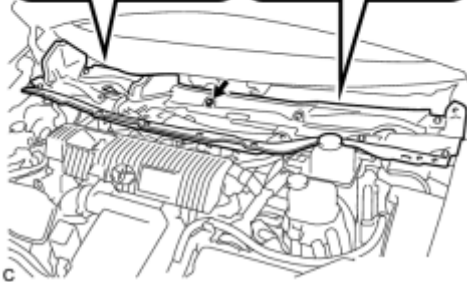

(b) Bend the water guard plate RH and engage the claw.

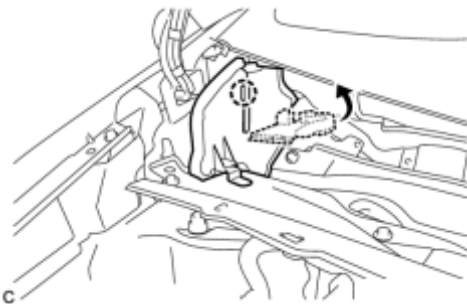

(c) Bend the No. 1 heater air duct splash shield seal and engage the claw.

(d) Engage the 2 clamps and guide to install the wire harness.

## Text in Illustration

*1	Clamp
*2	Guide

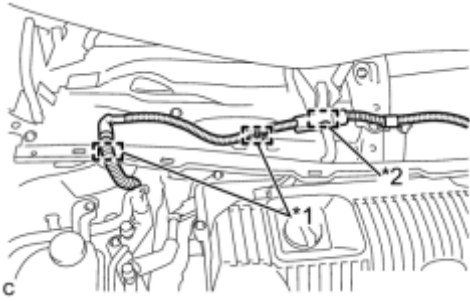

## 16. INSTALL COWL BODY MOUNTING REINFORCEMENT LH

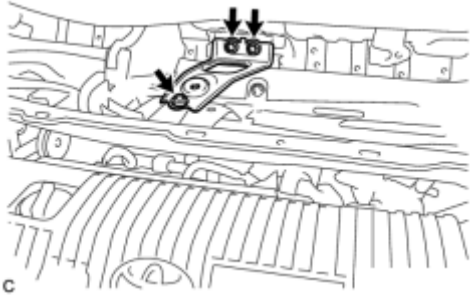

(a) Install the cowl body mounting reinforcement LH with the 3 bolts.

Torque: **12 N·m (122 kgf·cm, 9ft·lbf)**

## 17. INSTALL WINDSHIELD WIPER MOTOR AND LINK ASSEMBLY

HINT:

Refer to the procedure from Install Windshield Wiper Motor And Link Assembly [INFO](#).

## 18. INSTALL REAR NO. 3 FLOOR BOARD [INFO](#)

## 19. INSTALL REAR DECK FLOOR BOX [INFO](#)

## 20. INSTALL REAR NO. 2 FLOOR BOARD (for Separate Type) [INFO](#)

# COMPONENTS

# ILLUSTRATION

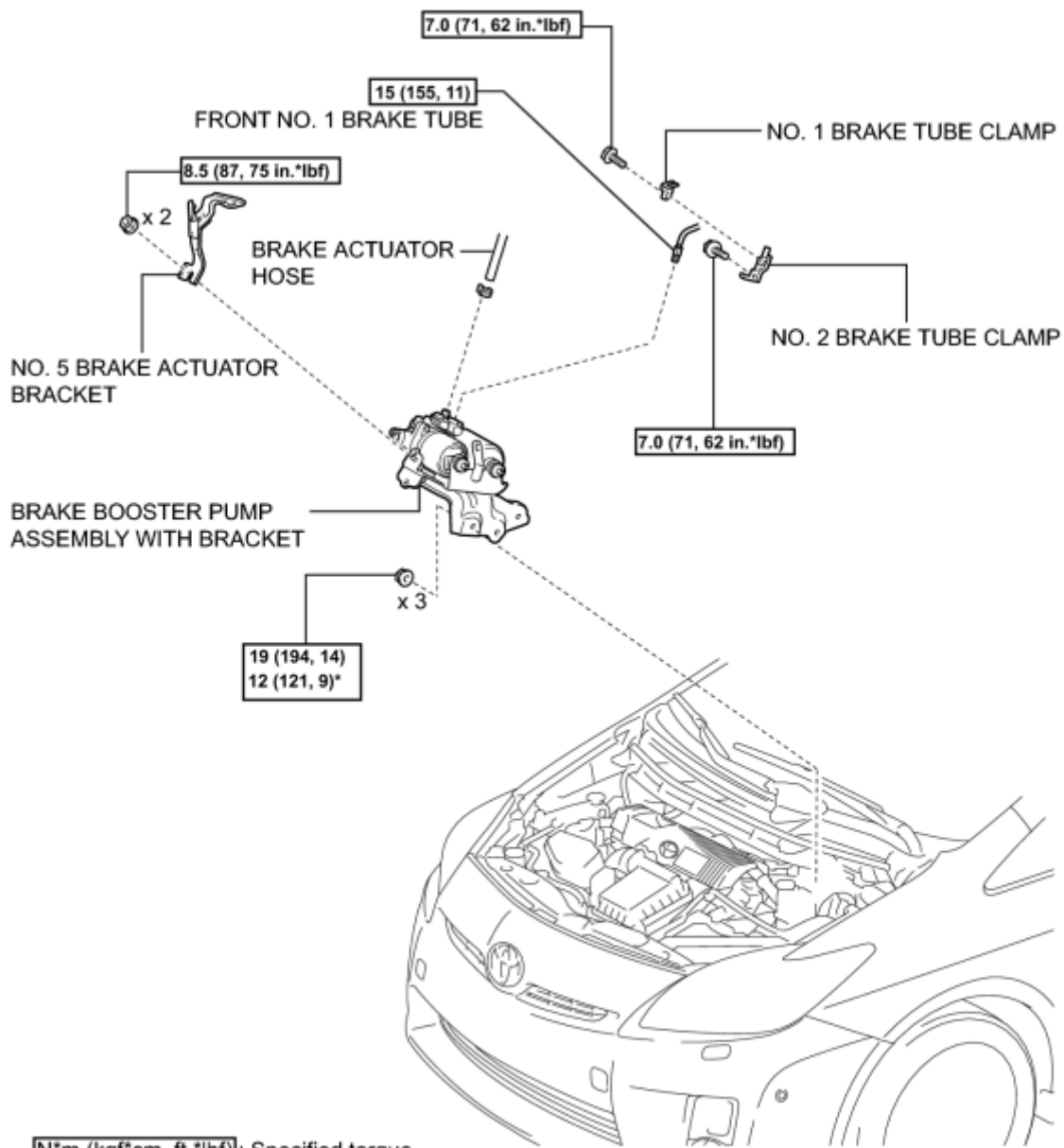

**N\*m (kgf\*cm, ft.\*lbf)**: Specified torque

\* For use with SST

P

# ILLUSTRATION

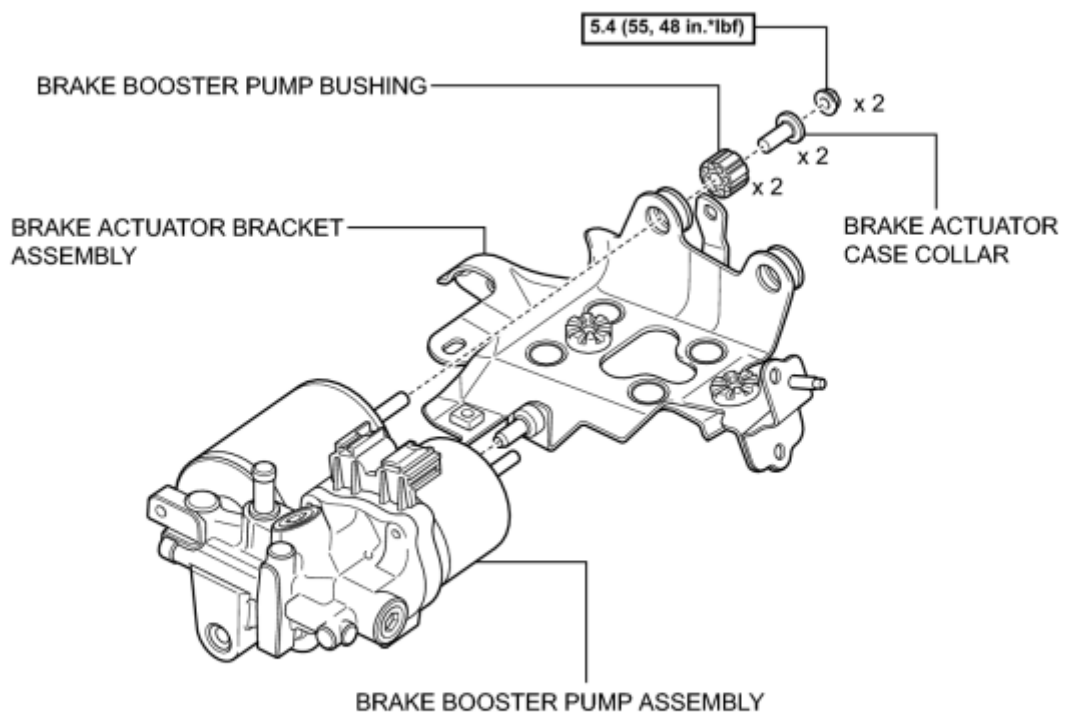

**N\*m (kgf\*cm, ft.\*lbf)**: Specified torque

c

# REMOVAL

## 1. REMOVE BRAKE BOOSTER WITH MASTER CYLINDER ASSEMBLY

HINT:

Refer to the procedure up to Remove Brake Booster with Master Cylinder Assembly INFO.

## 2. REMOVE FRONT CROSS MEMBER SUB-ASSEMBLY

HINT:

Refer to the procedure up to Remove Front Cross Member Sub-assembly INFO.

## 3. REMOVE NO. 5 BRAKE ACTUATOR BRACKET

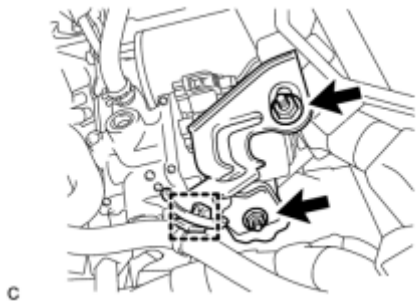

(a) Remove the 2 nuts and No. 5 brake actuator bracket.

(b) Separate the wire harness clamp.

## 4. REMOVE BRAKE BOOSTER PUMP ASSEMBLY WITH BRACKET

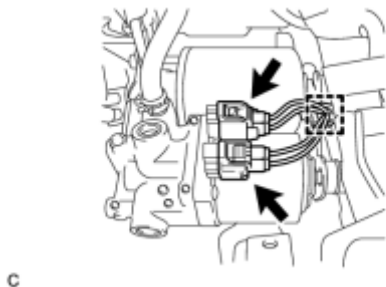

(a) Disconnect the 2 connectors and separate the clamp from the brake booster pump assembly.

(b) Remove the clip and brake actuator hose.

### Text in Illustration

*1	Brake Actuator Hose
*2	No. 2 Brake Tube Clamp



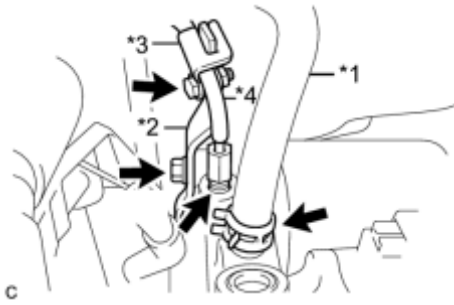

*3	No. 1 Brake Tube Clamp
*4	Front No. 1 Brake Tube

(c) Remove the 2 bolts, No. 1 brake tube clamp and No. 2 brake tube clamp.

(d) Disconnect the front No. 1 brake tube.

(e) Separate the wire harness clamp, 2 fuel lines and front No. 4 brake tube from the brake booster pump assembly.

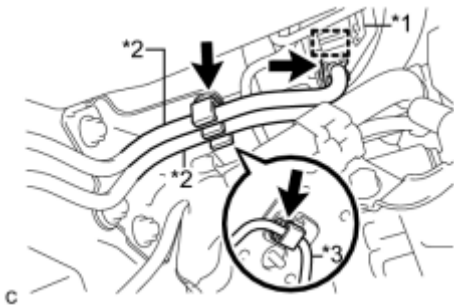

### Text in Illustration

*1	Wire Harness Clamp
*2	Fuel Line
*3	Front No. 4 Brake Tube

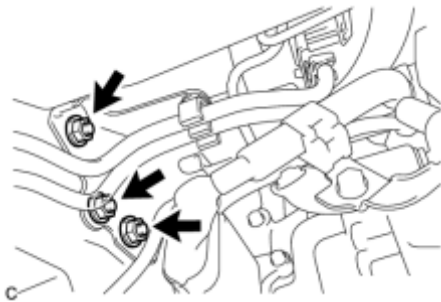

(f) Remove the 3 nuts and brake booster pump assembly with bracket.

## 5. REMOVE BRAKE BOOSTER PUMP ASSEMBLY

(a) Remove the 2 nuts, brake booster pump bushings, brake actuator case collars and brake booster pump assembly from the brake actuator bracket assembly.

### Text in Illustration

*1	Nut
*2	Brake Actuator Case Collar
*3	Brake Booster Pump Bushing
*4	Brake Actuator Bracket Assembly

*5	Brake Booster Pump Assembly
----	-----------------------------

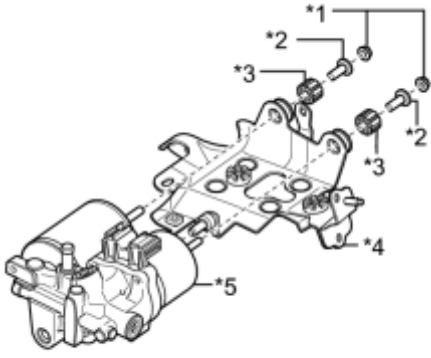

c

# INSPECTION

## 1. INSPECT BRAKE BOOSTER PUMP ASSEMBLY

(a) Measure the resistance according to the value(s) in the table below.

Standard Resistance:

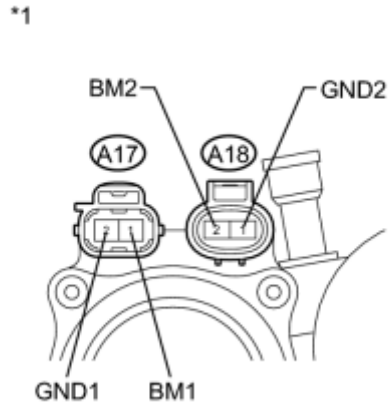

Tester Connection	Condition	Specified Condition
A17-1 (BM1) - A17-2 (GND1)	Always	Below 10 Ω
A18-2 (BM2) - A18-1 (GND2)	Always	Below 10 Ω
A17-1 (BM1) - A18-2 (BM2)	Always	Below 1 Ω
A17-2 (GND1) - A18-1 (GND2)	Always	Below 1 Ω

### Text in Illustration

*1	Component without harness connected (Brake Booster Pump)
----	---

# INSTALLATION

## 1. INSTALL BRAKE BOOSTER PUMP ASSEMBLY

(a) Install the brake booster pump assembly, brake booster pump bushings and brake actuator case collars to the brake actuator bracket assembly with the 2 nuts.

### Text in Illustration

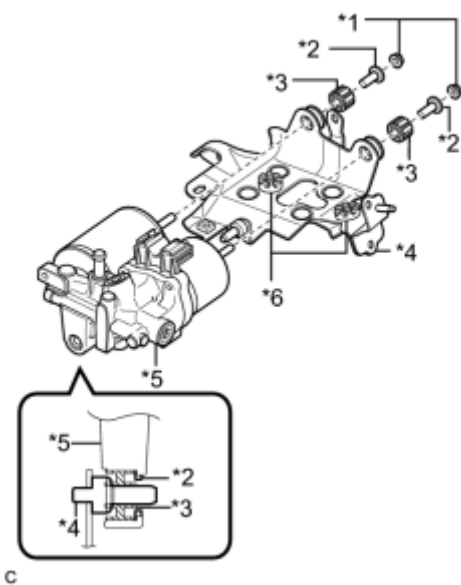

*1	Nut
*2	Brake Actuator Case Collar
*3	Brake Booster Pump Bushing
*4	Brake Actuator Bracket Assembly
*5	Brake Booster Pump Assembly
*6	Cushion

Torque: **5.4 N·m (55 kgf·cm, 48in·lbf)**

- Do not drop the brake booster pump assembly when carrying it.
- Do not carry the brake booster pump assembly by the connector.
- Confirm that the 2 cushions are on the brake actuator bracket, bushings and collars on the brake booster pump assembly when assembling the brake booster pump assembly.
- Do not remove the hole plug before installing a new brake booster pump assembly because the brake booster pump assembly is filled with brake fluid.

## 2. INSTALL BRAKE BOOSTER PUMP ASSEMBLY WITH BRACKET

(a) Using SST, install the brake booster pump assembly with bracket with the 3 nuts.

SST: 09961-00950

without SST - Torque: **19 N·m (194 kgf·cm, 14ft·lbf)**

with SST - Torque: **12 N·m (121 kgf·cm, 9ft·lbf)**

- Use a torque wrench with a fulcrum length of 250 mm (9.84 in.).
- Tighten the 3 nuts in the order shown in the illustration.
- Do not damage the fuel line, the brake lines and wire harness.
- Use the formula to calculate special torque values for situations where the SST is combined with a torque wrench [INFO](#).



(b) Install the wire harness clamp, 2 fuel lines and front No. 4 brake tube to the brake booster pump assembly.

**NOTICE:**

Do not damage the fuel line, the brake lines and wire harness.

**Text in Illustration**

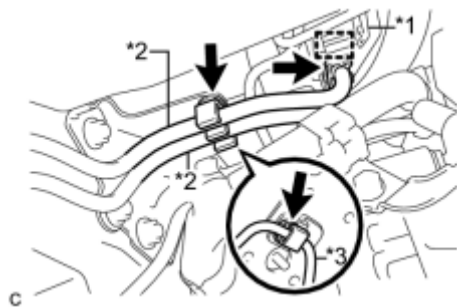

*1	Wire Harness Clamp
*2	Fuel Line
*3	Front No. 4 Brake Tube

(c) Connect the front No. 1 brake tube.

(1) Install the No. 2 brake tube clamp to the brake booster pump assembly with the bolt.

Torque: 7.0 N·m (71 kgf·cm, 62in·lbf)

**Text in Illustration**

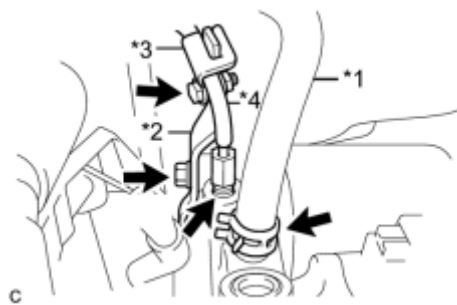

*1	Brake Actuator Hose
*2	No. 2 Brake Tube Clamp
*3	No. 1 Brake Tube Clamp
*4	Front No. 1 Brake Tube

(2) Install the front No. 1 brake tube to the brake booster pump assembly.

Torque: **15 N·m (155 kgf·cm, 11ft·lbf)**

NOTICE:

- This torque value is effective when the union nut wrench is parallel to the torque wrench.
- Use the formula to calculate special torque values for situations where the union nut wrench is combined with a torque wrench **INFO**.

(3) Install the No. 1 brake tube clamp to the brake booster pump assembly with the bolt.

Torque: **7.0 N·m (71 kgf·cm, 62in·lbf)**

(d) Install the brake actuator hose and clip.

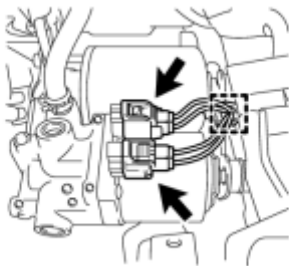

(e) Install the wire harness clamp.

c

(f) Connect the 2 connectors.

### 3. INSTALL NO. 5 BRAKE ACTUATOR BRACKET

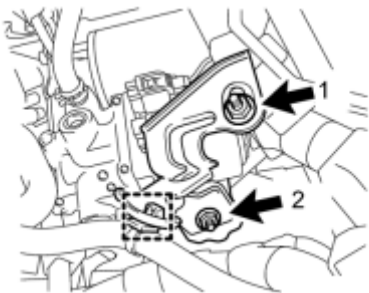

(a) Install the No. 5 brake actuator bracket with the 2 nuts.

Torque: **8.5 N·m (87 kgf·cm, 75in·lbf)**

NOTICE:

Tighten the 2 nuts in the order shown in the illustration.

c

(b) Install the wire harness clamp.

### 4. INSTALL FRONT CROSS MEMBER SUB-ASSEMBLY

HINT:

Refer to the procedure from Install Front Cross Member Sub-assembly **INFO**.

### 5. INSTALL BRAKE BOOSTER WITH MASTER CYLINDER ASSEMBLY

HINT:

Refer to the procedure from Install Brake Booster with Master Cylinder Assembly **INFO**.

## 6. INSPECT AND ADJUST FRONT WHEEL ALIGNMENT

(a) Adjust front wheel alignment **INFO**.

# DISPOSAL

## 1. DISPOSE OF BRAKE BOOSTER PUMP ASSEMBLY

- (a) Remove the accumulator from the brake booster pump assembly.
- (b) Secure the accumulator in a vise.
- (c) Using a hacksaw, make a cut in the side of the accumulator at location [A] to release the high-pressure gas.

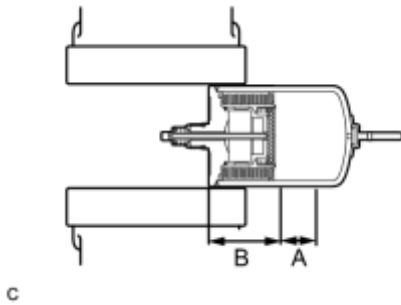

Point	Area
A	25 mm (0.984 in.)
B	60 mm (2.362 in.)

### CAUTION:

Small pieces of metal may fly out when cutting into the accumulator. Put a cloth over the hacksaw when cutting the accumulator. Cut the accumulator slowly so that the gas will be released gradually.

### HINT:

The gas is colorless, odorless and non-poisonous.



# ON-VEHICLE INSPECTION

## NOTICE:

If using a dropper to adjust the fluid amount, make sure that the dropper has not been used with mineral oils, water or deteriorated brake fluid. Sealed areas may deteriorate and lead to fluid leaks, or the fluid may deteriorate and lead to decreased efficiency.

## HINT:

If the brake fluid level is lower than the MIN line, inspect for brake fluid leaks and brake pad wear. After repair or replacement, adjust the brake fluid level in the reservoir as specified below.

### 1. INSPECT AND ADJUST FLUID LEVEL IN RESERVOIR (for Using the Techstream)

- (a) Connect the Techstream to the DLC3 with the power switch off.
- (b) Check that park (P) is selected and the parking brake is applied, and turn the power switch on (IG).
- (c) Turn the Techstream on and enter the following menus: Chassis / ABS/VSC/TRC / Utility / ECB (Electronically Controlled Brake system) utility / Zero Down.
- (d) Select "Next" and wait for 10 seconds.
- (e) After the booster pump stopped, inspect the fluid level is between the MAX and MIN lines. If necessary, refill the brake fluid to the MAX line.

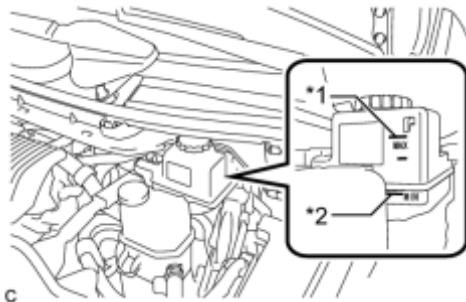

### Text in Illustration

*1	MAX Line
*2	MIN Line

Brake fluid:

SAE J1703 or FMVSS No. 116 DOT3

### 2. INSPECT AND ADJUST FLUID LEVEL IN RESERVOIR (for not Using the Techstream)

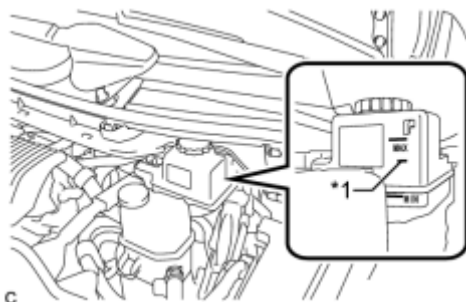

- (a) Inspect the fluid level is above the MIN line with the power switch on (IG). If necessary, refill the brake fluid to the fluid level support line with the power switch on (IG).

### Text in Illustration

*1	Fluid Level Support Line
----	--------------------------

# REPLACEMENT

## HINT:

There are 2 ways of brake fluid replacement: using the Techstream or not using the Techstream.

## NOTICE:

- Perform fluid replacement with park (P) selected and the parking brake applied.
- As brake fluid may overflow when replacing brake fluid, do not place the fluid can on the reservoir filler opening.
- Perform fluid replacement while maintaining the brake fluid level between the MIN/MAX level on the brake fluid reservoir.
- Replacing brake fluid will be difficult if the following occurs:
  - a. The brake actuator hose (the hose between the brake booster pump and brake fluid reservoir) is lowered into the fluid and air enters the hose.
  - b. During the fluid replacement procedure, air enters the brake booster pump while operating the pump motor.
- While performing fluid replacement, the accumulator pressure drop may cause a buzzer to sound. As there is no problem, continue with the fluid replacement.
- During fluid replacement, DTCs for pressure sensor malfunctions, etc. may be stored. After fluid replacement and if instructed in the procedures, clear the DTCs.
- Do not allow brake fluid to adhere to any painted surface such as the vehicle body. If brake fluid leaks onto any painted surface, immediately clean it off.

## 1. REPLACE BRAKE FLUID (for Using the Techstream)

### NOTICE:

- Add brake fluid carefully and check that the reservoir level remains between the MIN and MAX lines.
- Do not stand the fluid can on the reservoir inlet. Doing so will cause brake fluid to overflow.

(a) Remove the center cowl top ventilator cover.

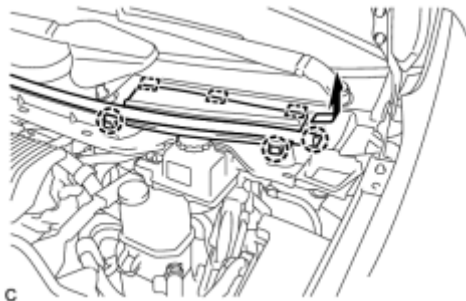

(1) Slide the hood to cowl top seal and disengage the claw.

(2) Disengage the 2 claws and 3 guides, and remove the center cowl top ventilator cover.

(b) Replace brake fluid.

(1) Remove the brake master cylinder reservoir filler cap assembly.

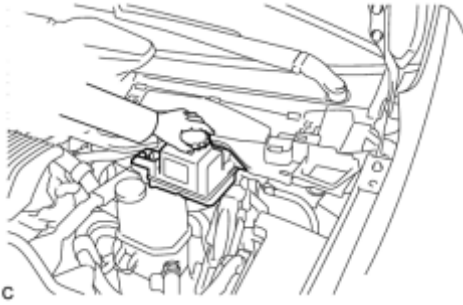

(2) Add brake fluid into the reservoir between MAX and MIN level on the brake fluid reservoir.

Brake fluid:

SAE J1703 or FMVSS No. 116 DOT3

(3) Connect the Techstream to the DLC3 and turn the power switch on (IG).

(4) Turn the Techstream on and enter the following menus: Chassis / ABS/VSC/TRC / Air Bleeding.

(5) Select the "Usual air bleeding" on the Techstream display, and replace the brake fluid following the instructions on the Techstream.

(6) After replacing brake fluid, tighten each bleeder plug.

front bleeder plug - Torque: **8.3 N·m (85 kgf·cm, 73in·lbf)**

rear bleeder plug - Torque: **11 N·m (112 kgf·cm, 8ft·lbf)**

(c) Clear the DTCs INFO.

(d) Turn the Techstream off and turn the power switch off.

(e) Inspect for brake fluid leaks.

(f) Install the brake master cylinder reservoir filler cap.

(g) Install the center cowl top ventilator cover.

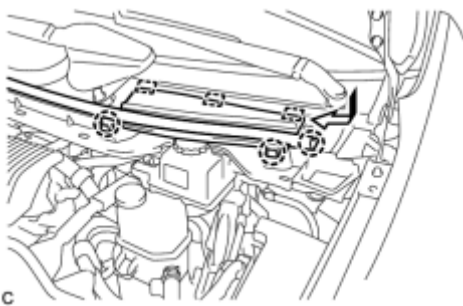

(1) Engage the 2 claws and 3 guides to install the center cowl top ventilator cover.

(2) Slide the hood to cowl top seal to engage the claw.

## 2. REPLACE BRAKE FLUID (for not Using the Techstream)

### NOTICE:

- Performing the following procedure will select ECB (Electronically Controlled Brake system) Invalid Mode without using the Techstream.
- ECB (Electronically Controlled Brake system) Invalid Mode allows the brake fluid to be replaced without using the Techstream.
- The brake warning light / yellow will blink to indicate when ECB (Electronically Controlled Brake system) Invalid Mode is selected.
- Be sure to inspect that the brake warning light / yellow is blinking while replacing the brake fluid.
- When one of the following conditions is met, ECB (Electronically Controlled Brake system) Invalid Mode is cancelled, and then the DTCs may be stored. So do not cancel the ECB (Electronically Controlled Brake system) Invalid Mode while replacing brake fluid.

The shift lever is used to select from P to any other position.

Turn the power switch on (READY).

Turn the power switch off.

The parking brake is released.

The vehicle velocity is not 0 km/h (0 mph).

- Do not rotate the brake disc while ECB (Electronically Controlled Brake system) Invalid Mode is selected.
- When replacing the brake fluid from the brake line, do not depress the brake pedal to operate the brake booster pump more than 100 seconds. If the brake booster pump is operated more than 100 seconds, ECB (Electronically Controlled Brake system) Invalid Mode is automatically finished and the DTCs may be stored.
- Add brake fluid carefully and check that the reservoir level remains between the MIN and MAX lines.
- Do not stand the fluid can on the reservoir inlet. Doing so will cause brake fluid to overflow.

(a) Remove 4 wheels.

(b) Select ECB (Electronically Controlled Brake system) Invalid Mode.

(1) Perform the procedure listed below in 1 minute.

1. Turn the power switch on (IG) with park (P) selected and parking brake applied.
2. Select N and then depress the brake pedal more than 8 times in 5 seconds.
3. Push the P position switch and then depress the brake pedal more than 8 times in 5 seconds.
4. Select N and then depress the brake pedal more than 8 times in 5 seconds.
5. Push the P position switch.

(2) Check that the brake warning light / yellow is blinking.



N

(c) Remove the center cowl top ventilator cover.

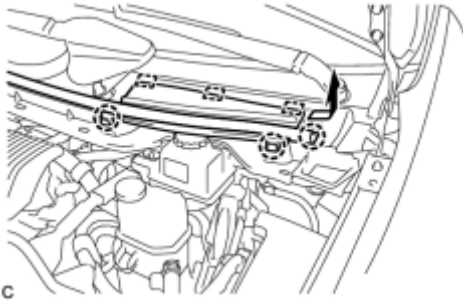

(1) Slide the hood to cowl top seal and disengage the claw.

(2) Disengage the 2 claws and 3 guides, and remove the center cowl top ventilator cover.

(d) Replace the brake fluid.

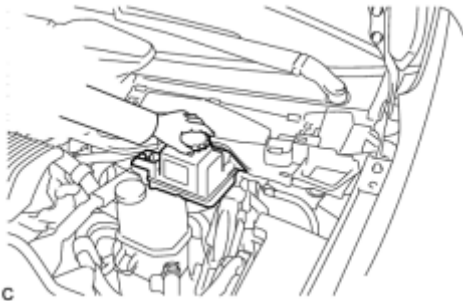

(1) Remove the brake master cylinder reservoir filler cap assembly.

(2) Add brake fluid into the reservoir between MAX and MIN level on the brake fluid reservoir.

Brake fluid:

SAE J1703 or FMVSS No. 116 DOT3

(3) Connect a vinyl tube to the bleeder plug of the front disc brake cylinder assembly RH.

(4) Depress the brake pedal several times, and then loosen the bleeder plug with the pedal depressed.\*1

(5) When fluid stops coming out, tighten the bleeder plug, and then release the brake pedal.\*2

(6) Repeat \*1 and \*2 until all the air in the brake fluid is completely bled out and a new brake fluid comes out.

(7) Tighten the bleeder plug completely.

Torque: **8.3 N·m (85 kgf·cm, 73in·lbf)**

(8) Replace the brake fluid from the front disc brake cylinder assembly LH using the same procedure as for RH.

(9) Connect a vinyl tube to the bleeder plug of the rear disc brake cylinder assembly LH.

(10) Loosen the bleeder plug while depressing and holding the brake pedal, and replace the brake fluid while the brake booster pump assembly and solenoid running.\*3

NOTICE:

- Be sure to keep the brake pedal depressed.
- Do not depress the brake pedal to operate the brake booster pump more than 100 seconds. When performing this procedure continuously, release the brake pedal to stop the brake booster pump operating and depress the brake pedal again.

(11) Tighten the bleeder plug, then release the brake pedal.\*4

(12) Repeat steps \*3 and \*4 until all the air in the brake fluid is completely bled out and a new brake fluid comes out.

(13) Tighten the bleeder plug completely.

Torque: **11 N·m (112 kgf·cm, 8ft·lbf)**

(14) Replace the brake fluid from the rear disc brake cylinder assembly RH using the same procedure as for LH.

(15) Turn the power switch off.

(e) Inspect for brake fluid leaks.

(f) Adjust the brake fluid level in the reservoir INFO.

(g) Install the brake master cylinder reservoir filler cap.

(h) Install the center cowl top ventilator cover.

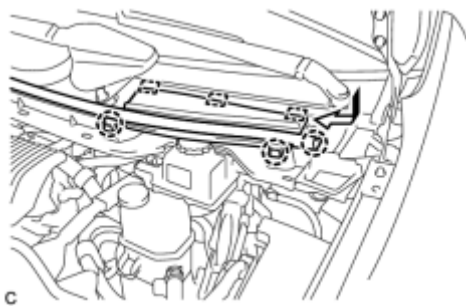

(1) Engage the 2 claws and 3 guides to install the center cowl top ventilator cover.

(2) Slide the hood to cowl top seal to engage the claw.

(i) Install the 4 wheels.

Torque: **103 N·m (1050 kgf·cm, 76ft·lbf)**

# BLEEDING

## CAUTION:

The Techstream must be used for air bleeding. If not used, the air bleeding will be incomplete, which is hazardous and may lead to an accident.

## NOTICE:

- Perform air bleeding with park (P) selected and the parking brake applied.
- As brake fluid may overflow when bleeding, do not place the fluid can on the reservoir filler opening.
- Perform air bleeding while maintaining the brake fluid level between the MIN/MAX level on the brake fluid reservoir.
- Air bleeding will be difficult if the following occurs:
  - a. The brake actuator hose (the hose between the brake booster pump and brake fluid reservoir) is lowered into the fluid and air enters the hose.
  - b. During the air bleeding procedure, air enters the brake booster pump while operating the pump motor.
- While performing air bleeding, the accumulator pressure drop may cause a buzzer to sound. As there is no problem, continue with the operation.
- During air bleeding, DTCs for pressure sensor malfunctions, etc. may be stored. After air bleeding and if instructed in the procedures, clear the DTCs.
- Release the parking brake while the linear valve offset calibration procedure.
- Do not allow brake fluid to adhere to any painted surface such as the vehicle body. If brake fluid leaks onto any painted surface, immediately clean it off.
- When bleeding air, select the suitable procedure according to the table below.

Replaced/Installed Item	Work Procedure
Flexible hose (front/rear)	Bleed brake line
Disc brake cylinder assembly (front/rear)	
Brake booster pump assembly	Bleed brake system
Brake booster with master cylinder assembly	
Brake master cylinder reservoir assembly	

## 1. BLEED BRAKE LINE

- (a) Remove the center cowl top ventilator cover.

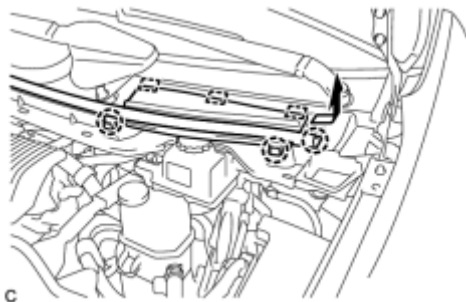

- (1) Slide the hood to cowl top seal and disengage the claw.



(2) Disengage the 2 claws and 3 guides, and remove the center cowl top ventilator cover.

(b) Bleed brake line.

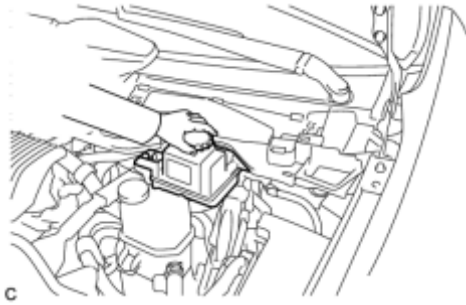

(1) Remove the brake master cylinder reservoir filler cap assembly.

(2) Add brake fluid into the reservoir between MAX and MIN level on the brake fluid reservoir.

Brake fluid:

SAE J1703 or FMVSS No. 116 DOT3

(3) Connect the Techstream to the DLC3 and turn the power switch on (IG).

(4) Turn the Techstream on and enter the following menus: Chassis / ABS/VSC/TRC / Air Bleeding.

(5) Select the "Usual air bleeding" on the Techstream display, and bleed air from the brake fluid following the instructions on the Techstream.

(6) After air bleeding, tighten each bleeder plug.

front bleeder plug - Torque: **8.3 N·m (85 kgf·cm, 73in·lbf)**

rear bleeder plug - Torque: **11 N·m (112 kgf·cm, 8ft·lbf)**

(7) Clear the DTCs .

(8) Turn the Techstream off and turn the power switch off.

(c) Inspect for brake fluid leaks.

(d) Install the brake master cylinder reservoir filler cap.

(e) Install the center cowl top ventilator cover.

(1) Engage the 2 claws and 3 guides to install the center cowl top ventilator cover.

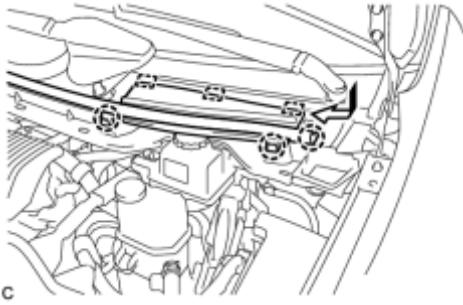

(2) Slide the hood to cowl top seal to engage the claw.

## 2. BLEED BRAKE SYSTEM

(a) Remove the outer cowl top panel sub-assembly INFO.

(b) Bleed the brake system.

(1) Wait at least 2 minutes with the power switch off, and disconnect the reservoir level switch connector.

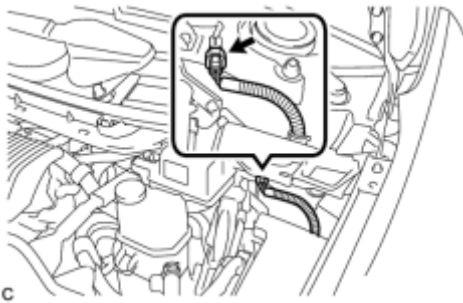

**NOTICE:**

Do not depress the brake pedal or open/close the doors until the reservoir level switch connector is disconnected.

**HINT:**

This procedure is not required if the reservoir level switch connector has been disconnected.

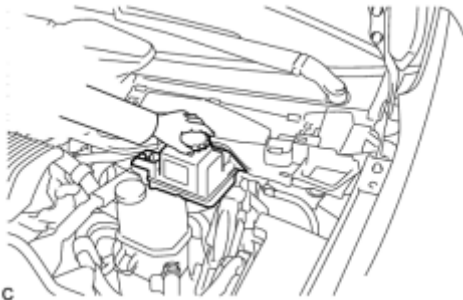

(2) Remove the brake master cylinder reservoir filler cap assembly.

(3) Add brake fluid into the reservoir between MAX and MIN level on the brake fluid reservoir.

Brake fluid:

SAE J1703 or FMVSS No. 116 DOT3

(4) Connect the Techstream to the DLC3 and turn the power switch on (IG).

(5) Turn the Techstream on and enter the following menus: Chassis / ABS/VSC/TRC / Air Bleeding.

(6) Select the "ABS actuator has been replaced" on the Techstream display, and bleed air from the brake fluid following the instructions on the Techstream.

**NOTICE:**

Before following the instructions on the Techstream to perform linear valve offset calibration, release the parking brake. When calibration is complete, immediately apply the parking brake.

(7) After air bleeding, tighten each bleeder plug.

front bleeder plug - Torque: **8.3 N·m (85 kgf·cm, 73in·lbf)**

rear bleeder plug - Torque: **11 N·m (112 kgf·cm, 8ft·lbf)**

stroke simulator bleeder plug - Torque: **8.5 N·m (87 kgf·cm, 75in·lbf)**

**HINT:**

The stroke simulator bleeder plug is positioned as shown in the illustration.

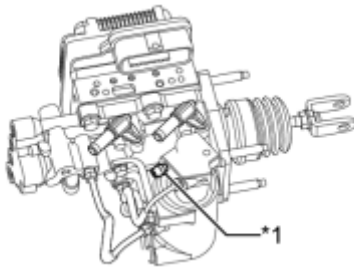

c

## Text in Illustration

*1	Stroke Simulator Bleeder Plug
----	-------------------------------

(8) Clear the DTCs **INFO**.

(9) Turn the Techstream off and turn the power switch off.

(c) Install the brake master cylinder reservoir filler cap.

(d) Inspect for brake fluid leaks.

(e) Install the outer cowl top panel sub-assembly **INFO**.

# PRECAUTION

## NOTICE:

- Since the brake lines are classified as critical safety related parts, be sure to disassemble and inspect the components if any brake fluid leaks are found. If any abnormality is found, replace the component with a new one.
- When removing brake system components, cover the brake line connections to prevent foreign matter such as dust or dirt from entering the lines.
- Do not allow brake fluid to adhere to any painted surface such as the vehicle body. If brake fluid leaks onto any painted surface, immediately clean it off.
- When installing a grommet to the body, ensure that the brake line passes through the center of the grommet.
- Do not damage or deform the brake lines when removing and installing them.
- When installing a brake line or flexible hose, ensure that they are free from twists or bends.
- Do not deform the bracket and the body when connecting a brake line and flexible hose.
- If the cap of a flexible hose does not match the groove on the bracket, twist the hose slightly to insert it.
- Flexible hoses must be free from shock absorber oil, grease, etc.
- When installing a brake line to a plastic clamp, ensure that the brake line is not loose or pinched.
- Do not reuse any clips or plastic clamps removed from a flexible hose.
- After installing a brake line or flexible hose, ensure that they do not interfere with any other components.
- When disconnecting and connecting a flexible hose and brake line:

Disconnecting:

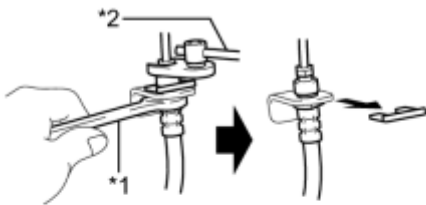

Connecting:

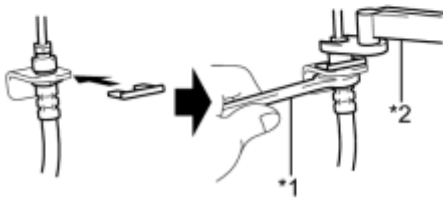

P

### Text in Illustration

*1	Hold
*2	Turn

- a. Hold the flexible hose with a wrench and disconnect the brake line with a union nut wrench without deforming the line.
- b. Remove the clip.
- c. Install a new clip.
- d. Connect the brake line with a union nut wrench without deforming the line.

- When connecting a brake line and way:

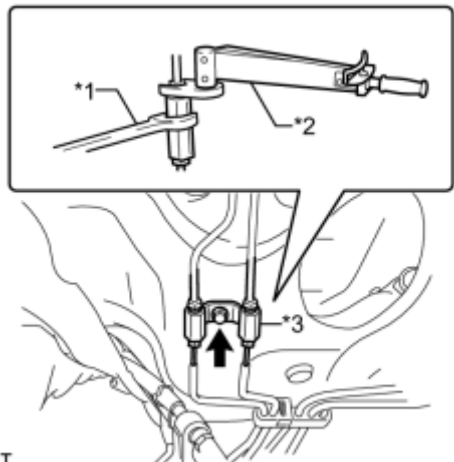

T

*Text in Illustration*

*1	Hold
*2	Turn
*3	Way

- Support the way to prevent deformation of the brake line and connect the brake line to the way with a union nut wrench.
- Support the way to prevent deformation of the brake line and install the bolt to secure the way to the body.

# SYSTEM DIAGRAM

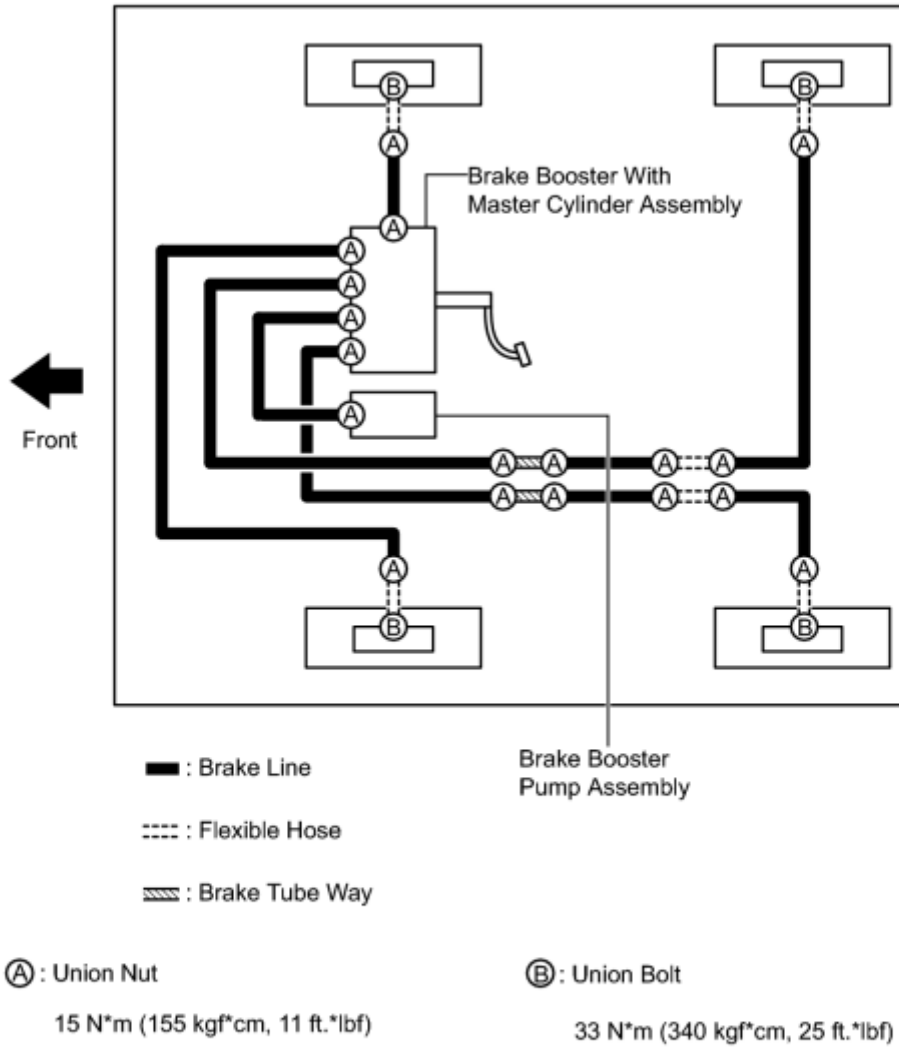

c

# COMPONENTS

# ILLUSTRATION



c

# ILLUSTRATION

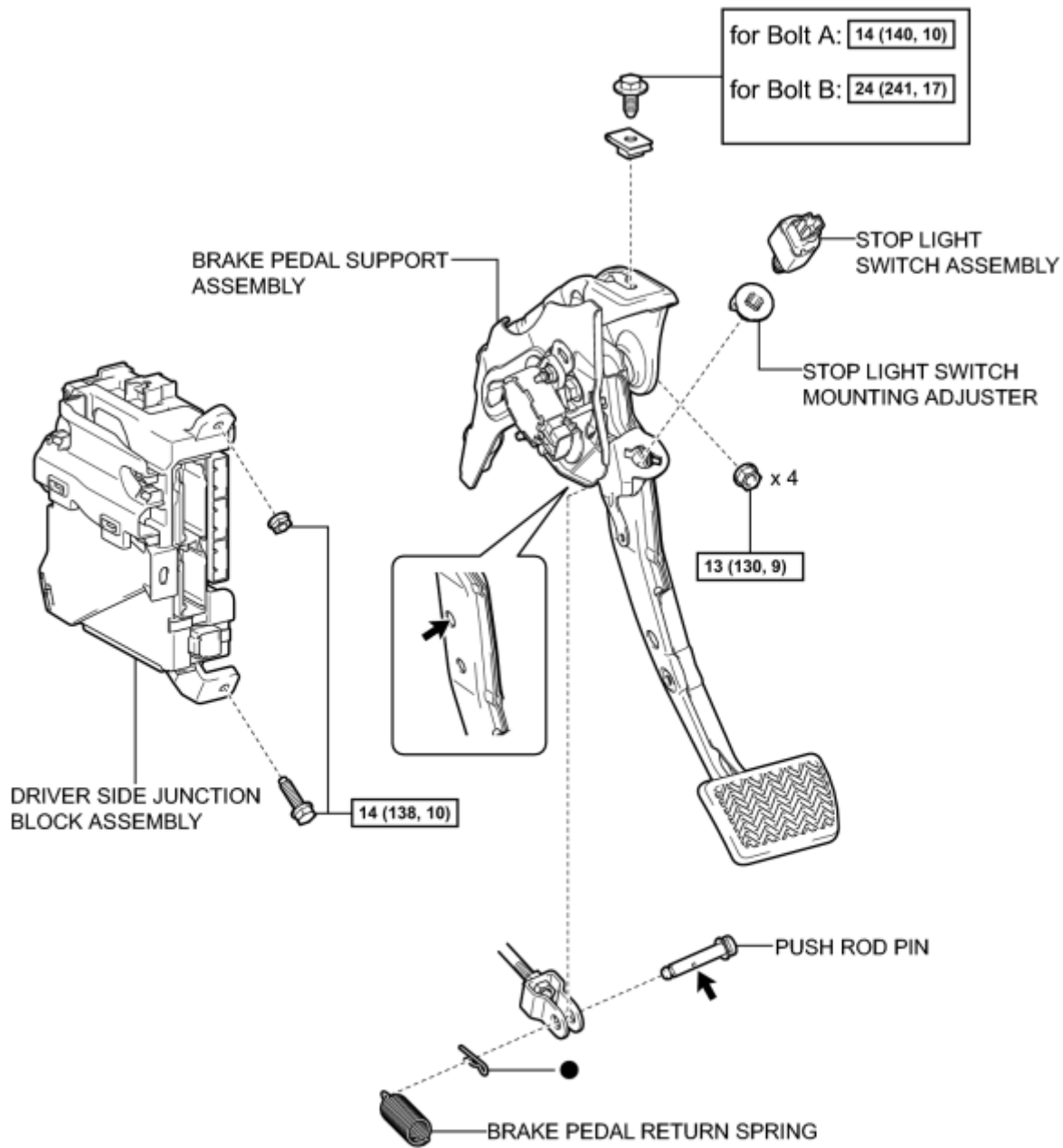

**[N\*m (kgf\*cm, ft.\*lbf)]** : Specified torque

● Non-reusable part

← Lithium soap base glycol grease

P

## ILLUSTRATION



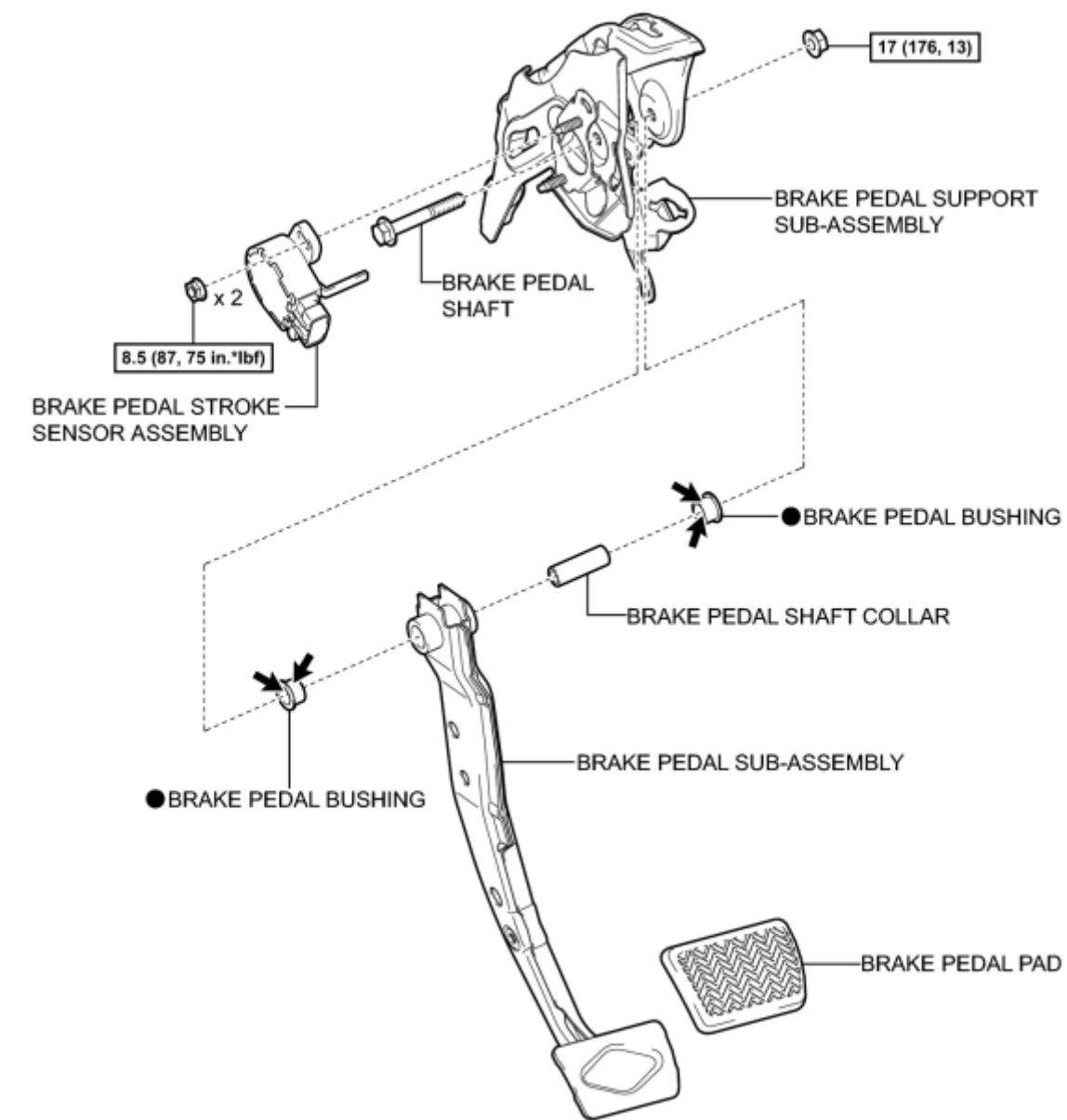

**N\*m (kgf\*cm, ft.\*lbf)** : Specified torque

● Non-reusable part

← Lithium soap base glycol grease

P

# REMOVAL

## 1. REMOVE UPPER INSTRUMENT PANEL ASSEMBLY

HINT:

Refer to the instructions for Removal of the upper instrument panel assembly [INFO](#).

## 2. REMOVE NO. 1 INSTRUMENT PANEL UNDER COVER SUB-ASSEMBLY [INFO](#)

## 3. REMOVE STOP LIGHT SWITCH ASSEMBLY [INFO](#)

## 4. REMOVE STOP LIGHT SWITCH MOUNTING ADJUSTER

## 5. REMOVE BRAKE PEDAL RETURN SPRING

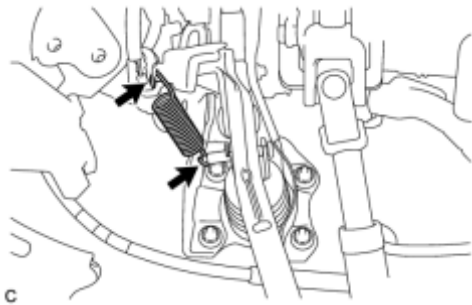

(a) Remove the brake pedal return spring from the brake pedal support sub-assembly and push rod pin.

## 6. REMOVE PUSH ROD PIN

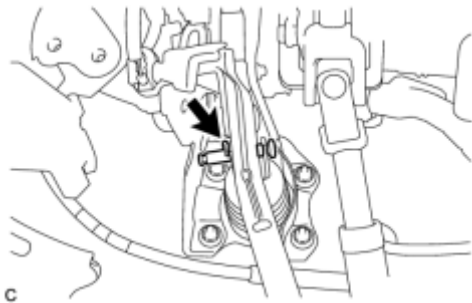

(a) Remove the clip and push rod pin to separate the brake pedal sub-assembly from the push rod clevis.

## 7. SEPARATE DRIVER SIDE JUNCTION BLOCK ASSEMBLY

(a) Remove the bolt and nut, and separate the driver side junction block assembly.

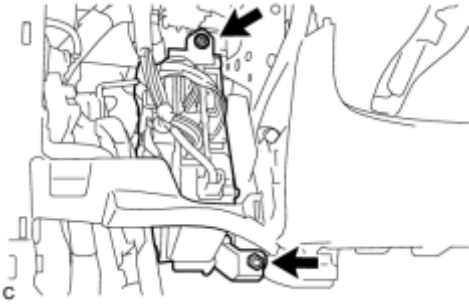

## 8. REMOVE BRAKE PEDAL SUPPORT ASSEMBLY

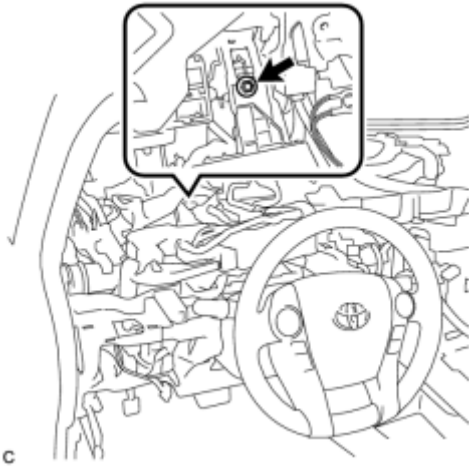

(a) Remove the bolt and separate the brake pedal support assembly from the instrument panel reinforcement.

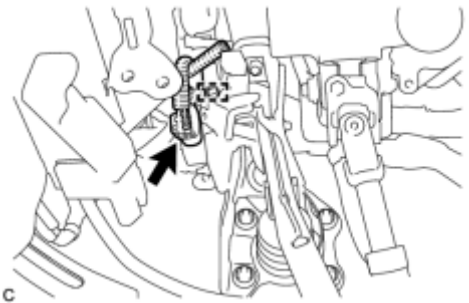

(b) Disengage the clamp and disconnect the connector from the brake pedal stroke sensor assembly.

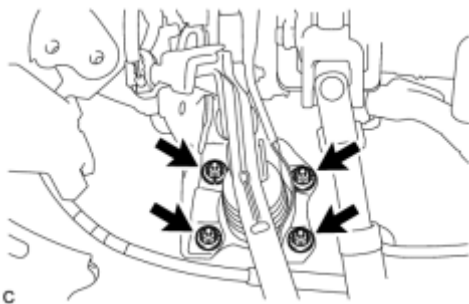

(c) Remove the 4 nuts and brake pedal support assembly.

(d) Remove the nut from the brake pedal support assembly.

c

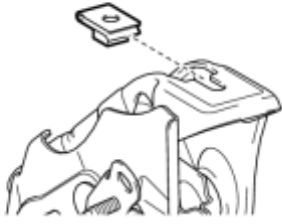

# DISASSEMBLY

1. REMOVE BRAKE PEDAL STROKE SENSOR ASSEMBLY INFO

2. REMOVE BRAKE PEDAL SUB-ASSEMBLY



(a) Remove the brake pedal shaft and nut to remove the brake pedal sub-assembly from the brake pedal support sub-assembly.

c

3. REMOVE BRAKE PEDAL SHAFT COLLAR

(a) Remove the brake pedal shaft collar from the brake pedal sub-assembly.

4. REMOVE BRAKE PEDAL BUSHING

(a) Remove the 2 brake pedal bushings from the brake pedal sub-assembly.

5. REMOVE BRAKE PEDAL PAD



# ADJUSTMENT

## 1. INSPECT AND ADJUST BRAKE PEDAL HEIGHT

(a) Check the brake pedal height.

(1) Turn back the carpet.

(2) Turn back the dash silencer from the slit provided on the dash silencer.

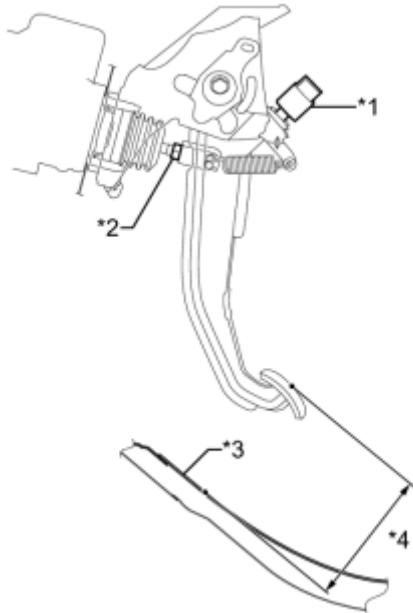

(3) Measure the shortest distance between the brake pedal surface and floor panel.

### Text in Illustration

*1	Stop Light Switch Assembly
*2	Clevis Lock Nut
*3	Floor Panel
*4	Brake Pedal Height

Brake pedal height from floor panel:

127.7 to 137.7 mm (5.03 to 5.42 in.)

(b) Adjust the brake pedal height.

(1) Remove the stop light switch assembly **INFO**.

(2) Loosen the clevis lock nut.

(3) Adjust the brake pedal height by turning the push rod.

(4) Tighten the clevis lock nut.

Torque: **26 N·m (260 kgf·cm, 19ft·lbf)**

(5) Install and adjust the stop light switch assembly **INFO**.

## 2. INSPECT AND ADJUST BRAKE PEDAL STROKE SENSOR ASSEMBLY **INFO**

## 3. INSPECT BRAKE PEDAL FREE PLAY

(a) Depress the pedal until a slight resistance is felt. Measure the brake

pedal free play as shown in the illustration.

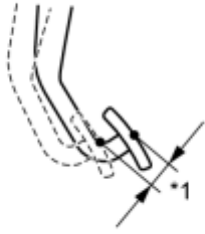

## Text in Illustration

*1	Brake Pedal Free Play
----	-----------------------

Pedal free play:

1.0 to 6.0 mm (0.0394 to 0.236 in.)

If the pedal free play is not as specified, check the stop light switch clearance [INFO](#). If the pedal free play is as specified, proceed to the Inspect Brake Pedal Reserve Distance procedure.

#### 4. INSPECT BRAKE PEDAL RESERVE DISTANCE

HINT:

Measure the distance at the same point used for the brake pedal height inspection.

(a) Release the parking brake pedal.

(b) With the power switch on (READY), depress the brake pedal and measure the pedal reserve distance.

Pedal reserve distance from the floor panel at 196 N (20 kgf, 44.1 lbf):

More than 78.0 mm (3.07 in.)

If the distance is not as specified, troubleshoot the brake system [INFO](#).



# REASSEMBLY

## 1. INSTALL BRAKE PEDAL PAD

## 2. INSTALL BRAKE PEDAL BUSHING

- (a) Apply lithium soap base glycol grease to 2 new brake pedal bushings.
- (b) Install the 2 brake pedal bushings to the brake pedal sub-assembly.

## 3. INSTALL BRAKE PEDAL SHAFT COLLAR

- (a) Install the brake pedal shaft collar to the brake pedal sub-assembly.

## 4. INSTALL BRAKE PEDAL SUB-ASSEMBLY



- (a) Install the brake pedal sub-assembly to the brake pedal support sub-assembly with the brake pedal shaft and nut.

**Torque: 17 N·m (176 kgf·cm, 13ft·lbf)**

c

## 5. INSTALL BRAKE PEDAL STROKE SENSOR ASSEMBLY INFO

# INSTALLATION

## 1. INSTALL BRAKE PEDAL SUPPORT ASSEMBLY



(a) Install the nut to the brake pedal support assembly.

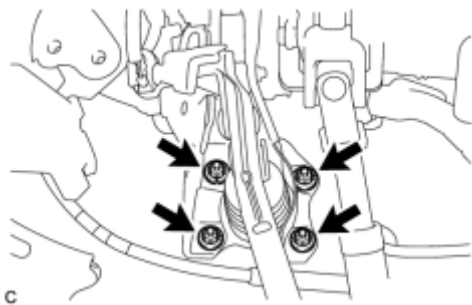

(b) Install the brake pedal support assembly with the 4 nuts.

Torque: **13 N·m (130 kgf·cm, 9ft·lbf)**

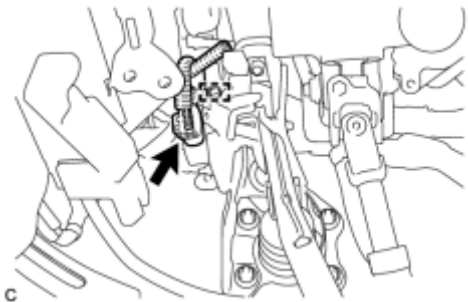

(c) Engage the clamp and connect the connector to the brake pedal stroke sensor assembly.

(d) Install the brake pedal support assembly to the instrument panel reinforcement with the bolt.

### Text in Illustration

*1	Bolt Width
<b>Bolt Variation</b>	<b>Bolt Width</b>
Bolt A	14 mm (0.551 in.)
Bolt B	12 mm (0.472 in.)

for Bolt A - Torque: **14 N·m (140 kgf·cm, 10ft·lbf)**

for Bolt B - Torque: **24 N·m (241 kgf·cm, 17ft·lbf)**

HINT:

Two types of bolts each with a different torque specification are used.

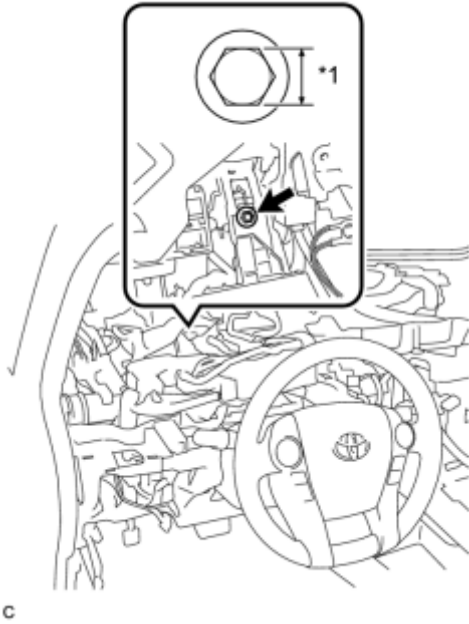

c

## 2. INSTALL DRIVER SIDE JUNCTION BLOCK ASSEMBLY

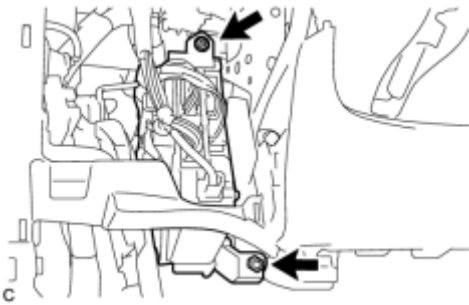

(a) Install the driver side junction block assembly with the bolt and nut.

Torque: **14 N·m (138 kgf·cm, 10ft·lbf)**

c

## 3. INSTALL PUSH ROD PIN

(a) Apply lithium soap base glycol grease to the push rod pin and installation hole of the brake pedal sub-assembly.

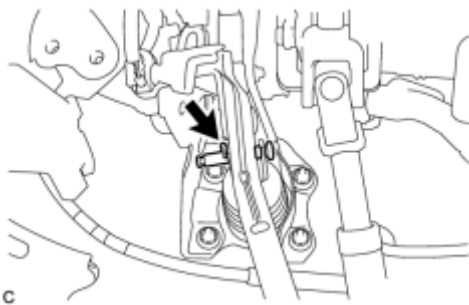

(b) Install the push rod pin and a new clip to connect the push rod clevis to the brake pedal sub-assembly.

c

## 4. INSTALL BRAKE PEDAL RETURN SPRING

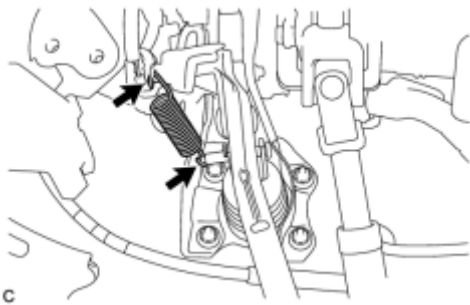

(a) Install the brake pedal return spring to the brake pedal support sub-assembly and push rod pin.

5. INSTALL STOP LIGHT SWITCH MOUNTING ADJUSTER

6. INSTALL STOP LIGHT SWITCH ASSEMBLY [INFO](#)

7. INSTALL UPPER INSTRUMENT PANEL ASSEMBLY

HINT:

Refer to the instructions for Installation of the upper instrument panel assembly [INFO](#).

8. INSPECT AND ADJUST BRAKE PEDAL

HINT: [INFO](#)

9. INSTALL NO. 1 INSTRUMENT PANEL UNDER COVER SUB-ASSEMBLY [INFO](#)

10. PERFORM INITIALIZATION AND CALIBRATION OF LINEAR SOLENOID VALVE

HINT: [INFO](#)

# PRECAUTION

## CAUTION:

- While the battery is connected, even if the power switch is off, the brake control system activates when the brake pedal is depressed or the door courtesy switch is turned on. Therefore during servicing of the brake system components, do not depress the brake pedal or open/close the doors while the battery is connected.
- The Techstream must be used when bleeding air. If not used, the air bleeding will be incomplete, which is hazardous and may lead to an accident.

## NOTICE:

- Care must be taken to replace each part properly as it could affect the performance of the brake system and result in a driving hazard. Replace the parts with those having the same part number or equivalent.
- It is very important to keep parts and the area clean when repairing the brake system.
- If the vehicle is equipped with a mobile communication system, refer to Precaution in the INTRODUCTION section .
- Care must be taken when using magnets as they could affect the performance of the speed sensors.
- Make sure to disable brake control before disconnecting the brake lines.

# PROBLEM SYMPTOMS TABLE

HINT:

Use the table below to help determine the cause of problem symptoms. If multiple suspected areas are listed, the potential causes of the symptoms are listed in order of probability in the "Suspected Area" column of the table. Check each symptom by checking the suspected areas in the order they are listed. Replace parts as necessary.

## Brake System

Symptom	Suspected Area	See page
Low or spongy pedal	Fluid leaks in brake system	-
	Air in brake system	<a href="#">INFO</a>
	Piston seals (Worn or damaged) (Front)	<a href="#">INFO</a>
	Piston seals (Worn or damaged) (Rear)	<a href="#">INFO</a>
	Brake booster with master cylinder assembly (Faulty)	<a href="#">INFO</a>
Brake drag	Brake pedal free play (Insufficient)	<a href="#">INFO</a>
	Parking brake pedal travel (Out of adjustment)	<a href="#">INFO</a>
	Parking brake cable (Sticking)	<a href="#">INFO</a>
	Pad (Cracked or distorted) (Front)	<a href="#">INFO</a>
	Pad (Cracked or distorted) (Rear)	<a href="#">INFO</a>
	Piston (Stuck) (Front)	<a href="#">INFO</a>
	Piston (Stuck) (Rear)	<a href="#">INFO</a>
	Piston (Seized) (Front)	<a href="#">INFO</a>
	Piston (Seized) (Rear)	<a href="#">INFO</a>
	Brake booster with master cylinder assembly (Faulty)	<a href="#">INFO</a>
Brake pull	Piston (Stuck) (Front)	<a href="#">INFO</a>
	Piston (Stuck) (Rear)	<a href="#">INFO</a>
	Pad (Oily) (Front)	<a href="#">INFO</a>
	Pad (Oily) (Rear)	<a href="#">INFO</a>
	Piston (Seized) (Front)	<a href="#">INFO</a>
	Piston (Seized) (Rear)	<a href="#">INFO</a>
	Disc (Scored) (Front)	<a href="#">INFO</a>
	Disc (Scored) (Rear)	<a href="#">INFO</a>
	Pad (Cracked or distorted) (Front)	<a href="#">INFO</a>
	Pad (Cracked or distorted) (Rear)	<a href="#">INFO</a>
Hard pedal but brake inefficient	Fluid leaks in brake system	-
	Air in brake system	<a href="#">INFO</a>
	Pad (Worn) (Front)	<a href="#">INFO</a>
	Pad (Worn) (Rear)	<a href="#">INFO</a>
	Pad (Cracked or distorted) (Front)	<a href="#">INFO</a>

Symptom	Suspected Area	See page
	Pad (Cracked or distorted) (Rear)	<a href="#">INFO</a>
	Pad (Oily) (Front)	<a href="#">INFO</a>
	Pad (Oily) (Rear)	<a href="#">INFO</a>
	Pad (Glazed) (Front)	<a href="#">INFO</a>
	Pad (Glazed) (Rear)	<a href="#">INFO</a>
	Disc (Scored) (Front)	<a href="#">INFO</a>
	Disc (Scored) (Rear)	<a href="#">INFO</a>
Noise from brakes	Pad (Cracked or distorted) (Front)	<a href="#">INFO</a>
	Pad (Cracked or distorted) (Rear)	<a href="#">INFO</a>
	Cylinder mounting bolt (Loose) (Front)	<a href="#">INFO</a>
	Cylinder mounting bolt (Loose) (Rear)	<a href="#">INFO</a>
	Disc (Scored) (Front)	<a href="#">INFO</a>
	Disc (Scored) (Rear)	<a href="#">INFO</a>
	Pad support plate (Loose) (Front)	<a href="#">INFO</a>
	Pad support plate (Loose) (Rear)	<a href="#">INFO</a>
	Slide pin (Worn) (Front)	<a href="#">INFO</a>
	Pad guide pin (Worn) (Rear)	<a href="#">INFO</a>
	Pad (Dirty) (Front)	<a href="#">INFO</a>
	Pad (Dirty) (Rear)	<a href="#">INFO</a>
	Pad (Glazed) (Front)	<a href="#">INFO</a>
	Pad (Glazed) (Rear)	<a href="#">INFO</a>
	Anti-squeal shim (Damaged) (Front)	<a href="#">INFO</a>
Anti-squeal shim (Damaged) (Rear)	<a href="#">INFO</a>	

# ON-VEHICLE INSPECTION

## NOTICE:

A DTC may be stored during the inspection procedure. Be sure to clear the DTC and check that a normal system code is output after the inspection is finished.

### 1. INSPECT PRESSURE SENSOR

(a) Check battery voltage.

Standard voltage:

11 to 14 V (while the power switch is off)

(b) Set a pedal effort gauge, SST (LSPV gauge) and connect the Techstream.

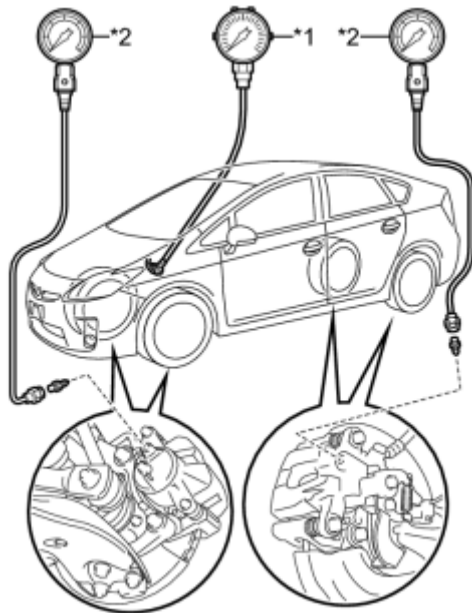

(1) Set a pedal effort gauge and SST (LSPV gauge).

SST: 09709-29018

### Text in Illustration

*1	Pedal Effort Gauge
*2	SST (LSPV Gauge)

(2) Bleed air from SST (LSPV gauge) **INFO**.

(3) Connect the Techstream to the DLC3 with the power switch off, park (P) selected and parking brake applied.

(4) Turn the power switch on (IG) and turn the Techstream on.

(5) Clear the DTCs **INFO**.

(c) Inspect wheel cylinder pressure sensor and regulator pressure sensor.

(1) Enter the following menus: Chassis / ABS/VSC/TRC / Active Test / Power Supply Air Bleeding Pattern 1.



(2) Select "Wheel Cylinder Pressure Sensor" and "Regulator Pressure Sensor Output".

(3) Check the value output from "Wheel Cylinder Pressure Sensor" and "Pressure Regulator Sensor Output" by depressing the brake pedal.

Standard Result:

<b>Pedal Effort</b>	<b>Regulator Pressure Sensor Output</b>	<b>Rear Right Wheel Hydraulic Pressure</b>	<b>Rear Left Wheel Hydraulic Pressure</b>
<b>N (kgf, lbf)</b>	<b>(V)</b>	<b>(MPa (kgf/cm<sup>2</sup>, psi))</b>	<b>(MPa (kgf/cm<sup>2</sup>, psi))</b>
50 (5, 11.2)	0.52 to 1.32	0.0 to 4.0 (0.0 to 40.7, 0 to 580)	0.0 to 4.0 (0.0 to 40.7, 0 to 580)
100 (10, 22.5)	1.35 to 2.15	4.1 to 8.1 (41.8 to 82.5, 595 to 1174)	4.1 to 8.1 (41.8 to 82.5, 595 to 1174)
150 (15, 33.7)	2.17 to 2.97	8.15 to 12.15 (83.1 to 123.8, 1182 to 1762)	8.15 to 12.15 (83.1 to 123.8, 1182 to 1762)
200 (20, 45.0)	3.00 to 3.80	12.20 to 16.20 (124.4 to 165.1, 1770 to 2349)	12.20 to 16.20 (124.4 to 165.1, 1770 to 2349)

Standard Result:

<b>Pedal Effort</b>	<b>Wheel Cylinder Pressure Sensor</b>	<b>Front Right Wheel Hydraulic Pressure</b>	<b>Front Left Wheel Hydraulic Pressure</b>
<b>N (kgf, lbf)</b>	<b>(V)</b>	<b>(MPa (kgf/cm<sup>2</sup>, psi))</b>	<b>(MPa (kgf/cm<sup>2</sup>, psi))</b>
50 (5, 11.2)	0.46 to 1.26	0.0 to 3.76 (0.0 to 38.3, 0 to 545)	0.0 to 3.76 (0.0 to 38.3, 0 to 545)
100 (10, 22.5)	1.17 to 1.97	3.22 to 7.22 (32.8 to 73.6, 467 to 1047)	3.22 to 7.22 (32.8 to 73.6, 467 to 1047)
150 (15, 33.7)	1.87 to 2.67	6.69 to 10.69 (68.2 to 109.0, 970 to 1550)	6.69 to 10.69 (68.2 to 109.0, 970 to 1550)
200 (20, 45.0)	2.58 to 3.38	10.13 to 14.13 (103.3 to 144.0, 1469 to 2049)	10.13 to 14.13 (103.3 to 144.0, 1469 to 2049)

(4) After inspection, turn "Power Supply Air Bleeding Pattern 1" off.

(d) Inspect accumulator sensor.

(1) Enter the following menus: Chassis / ABS/VSC/TRAC / Data List "Accumulator Sensor".

(2) Depress the brake pedal 4 or 5 times and operate the booster pump motor.

(3) After confirming that the booster pump motor stops, check the output voltage.

Standard voltage:

2.9 to 4.2 V

## 2. INSPECT BRAKE BOOSTER WITH MASTER CYLINDER ASSEMBLY

(a) Check battery voltage.

Standard voltage:

11 to 14 V (while the power switch is off)

(b) Connect the Techstream and set a pedal effort gauge.

(1) Set a pedal effort gauge.

(2) Connect the Techstream to the DLC3 with the power switch off, park (P) selected and parking brake applied.

(3) Turn the power switch on (IG) and turn the Techstream on.

(4) Clear the DTCs INFO.

(c) Check operation without the brake booster.

(1) Inspect and adjust the brake pedal height INFO.

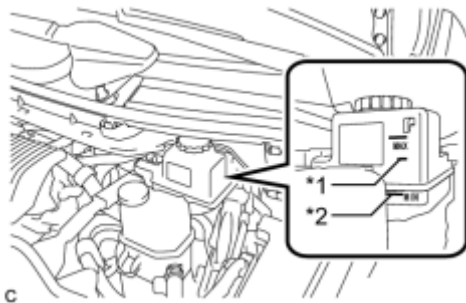

(2) Adjust the brake fluid level in the reservoir between MIN line and fluid level support line.

### Text in Illustration

*1	Fluid Level Support Line
*2	MIN Line

(3) Turn the Techstream on and enter the following menus: Chassis / ABS/VSC/TRAC / Utility / ECB (Electronically Controlled Brake system) Utility / Zero Down.

NOTICE:

Go to the next step without turning the power switch off.

(4) Enter the following menus: Chassis / ABS/VSC/TRAC / Data List "Wheel Cylinder Pressure Sensor", "Stroke Sensor" and "Stroke Sensor 2".

(5) Check the value output from "Wheel Cylinder Pressure Sensor", "Stroke Sensor" and "Stroke Sensor 2" by depressing the brake pedal.

Standard Voltage:

<b>Pedal Effort</b>	<b>Wheel Cylinder Pressure Sensor</b>	<b>Stroke Sensor</b>	<b>Stroke Sensor 2</b>
<b>N (kgf, lbf)</b>	<b>(V)</b>	<b>(V)</b>	<b>(V)</b>
200 (20, 45.0)	0.453 to 1.253	0.98 to 1.68	3.32 to 4.02
500 (51, 112.4)	0.982 to 1.782	1.15 to 1.86	3.14 to 3.84

(6) Turn the power switch off to finish "Zero Down".

(7) Turn the power switch on and wait at 20 seconds, then enter the following menus: Chassis / ABS/VSC/TRAC / Data List "Accumulator Sensor", and check the output voltage.

Standard voltage:

2.9 to 4.2 V

### 3. INSPECT STROKE SIMULATOR

(a) Check battery voltage.

Standard voltage:

11 to 14 V (while the power switch is off)

(b) Connect the Techstream and set a pedal effort gauge.

(1) Set a pedal effort gauge.

(2) Connect the Techstream to the DLC3 with the power switch off, park (P) selected and parking brake applied.

(3) Turn the power switch on (IG) and turn the Techstream on.

(4) Clear the DTCs .

(c) Check operation with the brake booster.

(1) Turn the power switch on (IG).

(2) Enter the following menus: Chassis / ABS/VSC/TRAC / Data List "Stroke Sensor" and "Stroke Sensor 2".

(3) Depress the brake pedal 4 or 5 times.

(4) Check the value output from "Stroke Sensor" and "Stroke Sensor 2" by depressing the brake pedal.

Standard Voltage:

<b>Pedal Effort</b>	<b>Stroke Sensor</b>	<b>Stroke Sensor 2</b>
<b>N (kgf, lbf)</b>	<b>(V)</b>	<b>(V)</b>

<b>Pedal Effort</b>	<b>Stroke Sensor</b>	<b>Stroke Sensor 2</b>
<b>N (kgf, lbf)</b>	<b>(V)</b>	<b>(V)</b>
50 (5 11.2)	1.03 to 1.73	3.26 to 3.96
100 (10, 22.4)	1.26 to 1.96	3.04 to 3.74
150 (15, 34.0)	1.30 to 2.00	3.00 to 3.70

# COMPONENTS

# ILLUSTRATION

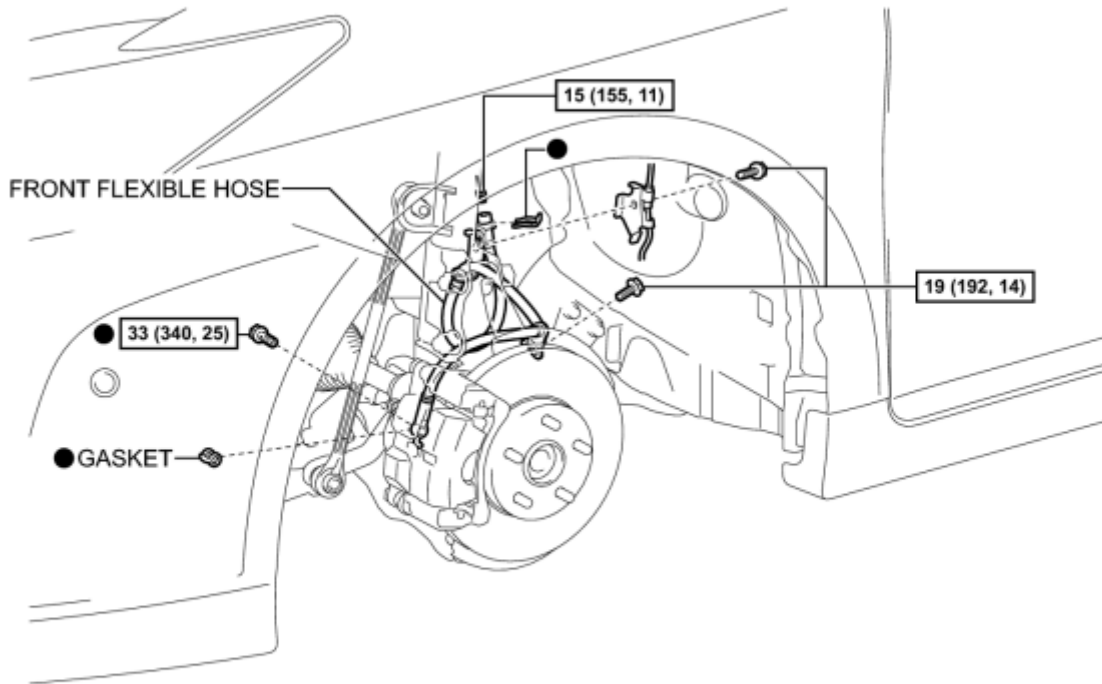

**N\*m (kgf\*cm, ft.\*lbf)** : Specified torque

● Non-reusable part

P

# REMOVAL

## NOTICE:

If both RH side hose and LH side hose are disconnected at the same time, be sure to place identification marks indicating the position on each side.

## HINT:

- Use the same procedure for the LH side and RH side.
- The following procedure is for the LH side.

### 1. DISABLE BRAKE CONTROL INFO

### 2. REMOVE FRONT WHEEL

### 3. DRAIN BRAKE FLUID

## NOTICE:

If brake fluid leaks onto any painted surface, immediately wash it off.

### 4. REMOVE FRONT FLEXIBLE HOSE

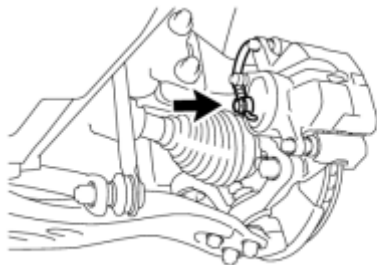

c

(a) Remove the union bolt and gasket, and separate the front flexible hose from the disc brake cylinder assembly.

(b) Using a union nut wrench, disconnect the brake line while holding the front flexible hose with a wrench.

## Text in Illustration

*1	Clip
----	------

- Do not kink or damage the brake line.
- Do not allow any foreign matter such as dirt or dust to enter the brake line from the clip or bracket.

(c) Remove the clip.

(d) Remove the bolt (A) and separate the front speed sensor bracket from

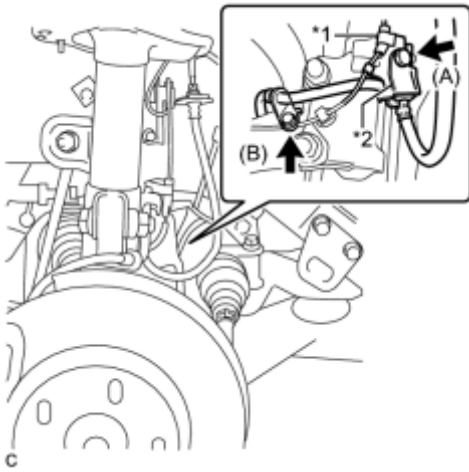

the absorber bracket.

## Text in Illustration

*1	Front Speed Sensor Bracket
*2	Front Flexible Hose Bracket

(e) Remove the bolt (B) and front flexible hose from the steering knuckle.

# INSTALLATION

## NOTICE:

- Because the left and right hoses are not interchangeable, verify the part number when installing the flexible hoses.
- If the hoses are to be reused, connect them after checking the identification marks placed when each hose was disconnected.

## HINT:

- Use the same procedure for the LH side and RH side.
- The following procedure is for the LH side.

### 1. INSTALL FRONT FLEXIBLE HOSE

(a) Install a new clip to the front flexible hose.

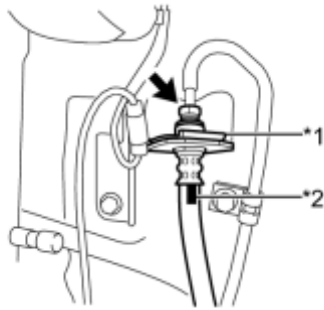

### Text in Illustration

*1	Clip
*2	Identification Mark

- Install the clip as far as it will go.
- When installing the front flexible hose, face the identification mark to the outside of the vehicle and minimize twisting of the hose.

(b) Using a union nut wrench, connect the brake line to the front flexible hose while holding the flexible hose with a wrench.

Torque: **15 N·m (155 kgf·cm, 11ft·lbf)**

## NOTICE:

- Do not kink or damage the brake line.
- Do not allow any foreign matter such as dirt or dust to enter the brake line from the clip or bracket.
- Use the formula to calculate special torque values for situations where the union nut wrench is combined with a torque wrench INFO.

(c) Install the front flexible hose to the steering knuckle with the bolt (B).

Torque: **19 N·m (192 kgf·cm, 14ft·lbf)**



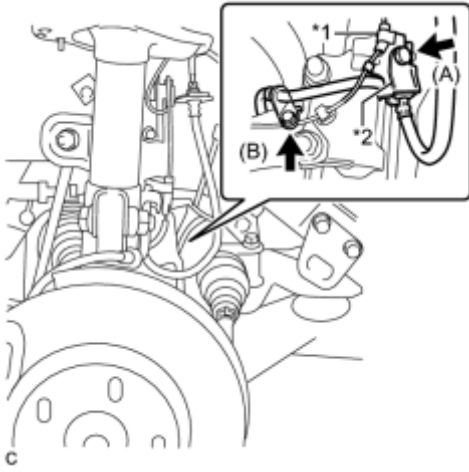

(d) Install the front flexible hose and front speed sensor bracket to the absorber bracket with the bolt (A).

**Text in Illustration**

*1	Front Speed Sensor Bracket
*2	Front Flexible Hose Bracket

Torque: **19 N·m (192 kgf·cm, 14ft·lbf)**

**NOTICE:**

Install the front flexible hose first and then the front speed sensor bracket.

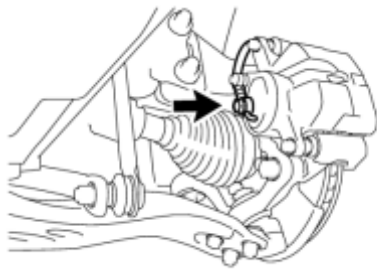

(e) Connect the front flexible hose to the front disc brake cylinder assembly with a new union bolt and a new gasket.

Torque: **33 N·m (340 kgf·cm, 25ft·lbf)**

**2. BLEED BRAKE LINE** INFO

**3. PERFORM INITIALIZATION AND CALIBRATION OF LINEAR SOLENOID VALVE**

**HINT:**

If the brake control has been disabled, make sure to perform initialization and calibration of the linear solenoid valve INFO.

**4. INSTALL FRONT WHEEL**

Torque: **103 N·m (1050 kgf·cm, 76ft·lbf)**

# COMPONENTS

# ILLUSTRATION

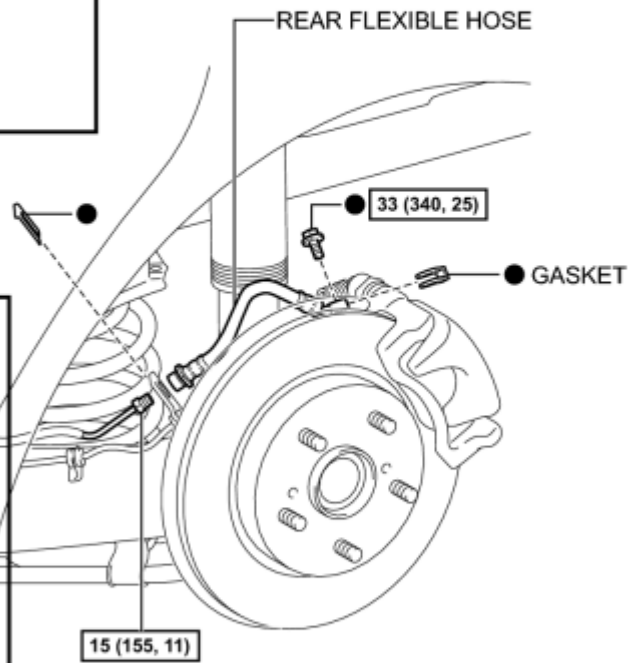
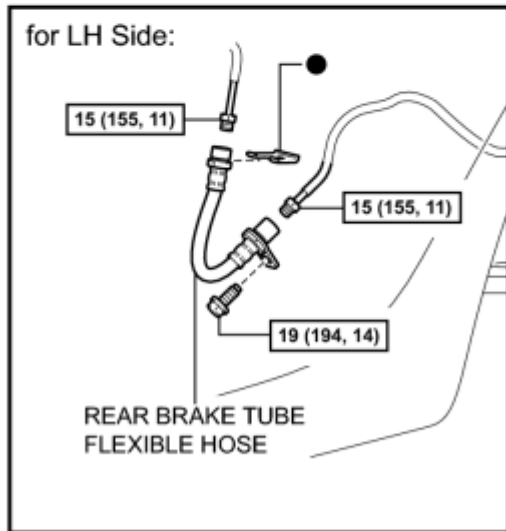
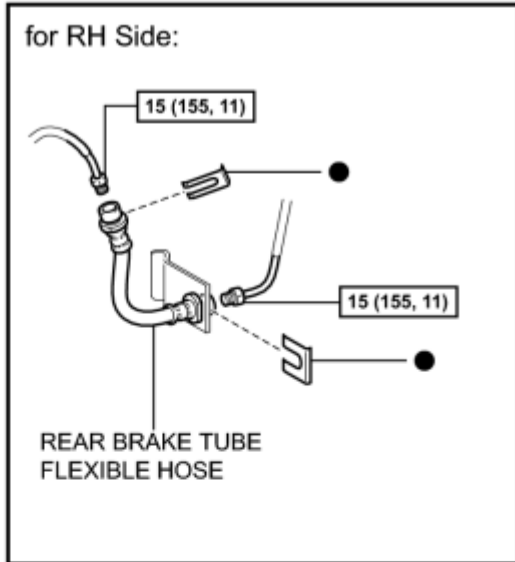

**N\*m (kgf\*cm, ft.\*lbf)** : Specified torque

● Non-reusable part

T

# REMOVAL

## NOTICE:

If both RH side hose and LH side hose are disconnected at the same time, be sure to place identification mark indicating the position on each side.

## HINT:

- Use the same procedure for the LH side and RH side.
- The following procedure is for the LH side.

### 1. DISABLE BRAKE CONTROL INFO

### 2. REMOVE REAR WHEEL

### 3. DRAIN BRAKE FLUID

## NOTICE:

If brake fluid leaks onto any painted surface, immediately wash it off.

### 4. REMOVE REAR BRAKE TUBE FLEXIBLE HOSE (for LH Side)

(a) Using a union nut wrench, disconnect the 2 brake lines while holding the rear brake tube flexible hose with a wrench.

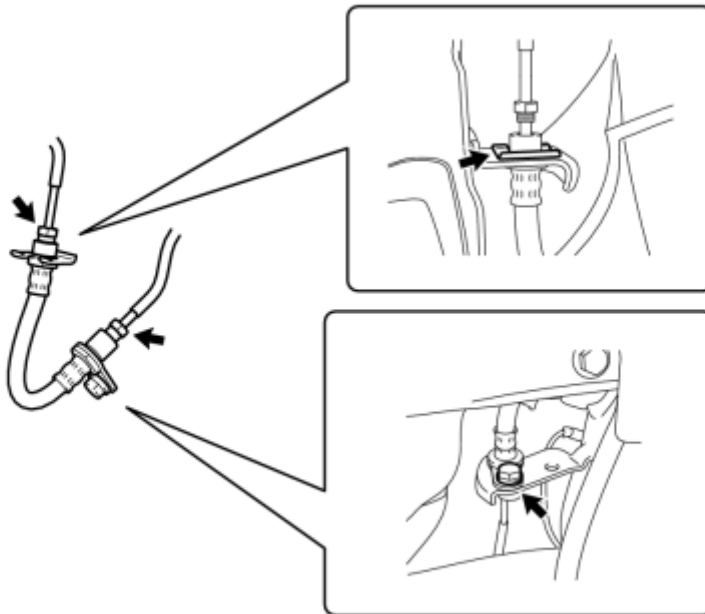

c

## NOTICE:

- Do not bend or damage the brake line.
- Do not allow any foreign matter such as dirt or dust to enter the brake line from the connecting points.

(b) Remove the clip, bolt and rear brake tube flexible hose.

#### 5. REMOVE REAR BRAKE TUBE FLEXIBLE HOSE (for RH Side)

(a) Using a union nut wrench, disconnect the 2 brake lines while holding the rear brake tube flexible hose with a wrench.

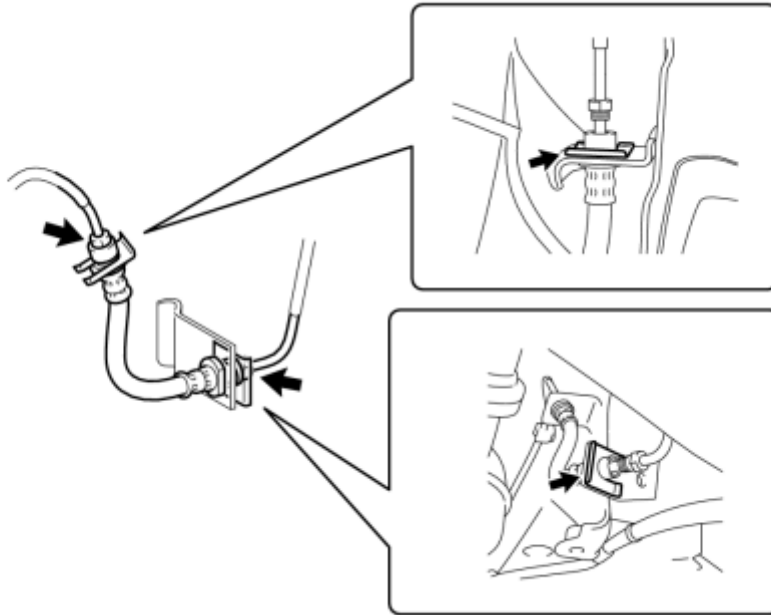

c

#### NOTICE:

- Do not bend or damage the brake line.
- Do not allow any foreign matter such as dirt or dust to enter the brake line from the connecting points.

(b) Remove the 2 clips and rear brake tube flexible hose.

#### 6. REMOVE REAR FLEXIBLE HOSE

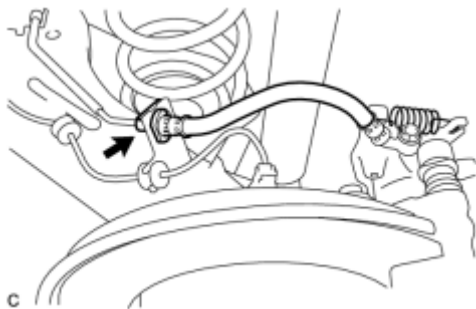

c

(a) Using a union nut wrench, Disconnect the brake line while holding the rear flexible hose with a wrench.

- Do not bend or damage the brake line.
- Do not allow any foreign matter such as dirt or dust to enter the brake line from the connecting points.

(b) Remove the clip and separate the rear flexible hose from the brake line.



(c) Remove the union bolt, gasket and rear flexible hose.

# INSTALLATION

## NOTICE:

- Because the left and right rear flexible hoses are not interchangeable, verify the part number when installing the flexible hoses.
- If the hoses are to be reused, connect them after checking the identification marks placed when each hose was disconnected.

## HINT:

- Use the same procedure for the LH side and RH side.
- The following procedure is for the LH side.

### 1. INSTALL REAR BRAKE TUBE FLEXIBLE HOSE (for LH Side)

(a) Install the rear brake tube flexible hose with the bolt and a new clip.

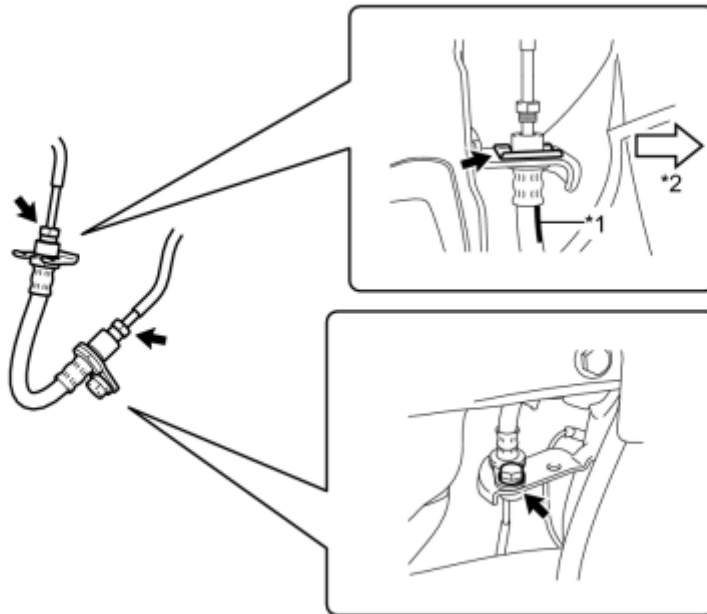

c

### *Text in Illustration*

*1	Identification Mark	*2	Inside of the Vehicle
----	---------------------	----	-----------------------

Torque: **19 N·m (194 kgf·cm, 14ft·lbf)**

## NOTICE:

- Install the clip as far as it will go.
- When installing the rear brake tube flexible hose, face the identification mark to the inside of the vehicle and minimize twisting of the hose.

(b) Using a union nut wrench, connect the 2 brake lines to the rear brake tube flexible hose.

Torque: **15 N·m (155 kgf·cm, 11ft·lbf)**

NOTICE:

- Do not bend or damage the brake line.
- Do not allow any foreign matter such as dirt and dust to enter the brake line from the connecting points.
- Use the formula to calculate special torque values for situations where the union nut wrench is combined with a torque wrench **INFO**.

## 2. INSTALL REAR BRAKE TUBE FLEXIBLE HOSE (for RH Side)

(a) Install the rear brake tube flexible hose with 2 new clips.

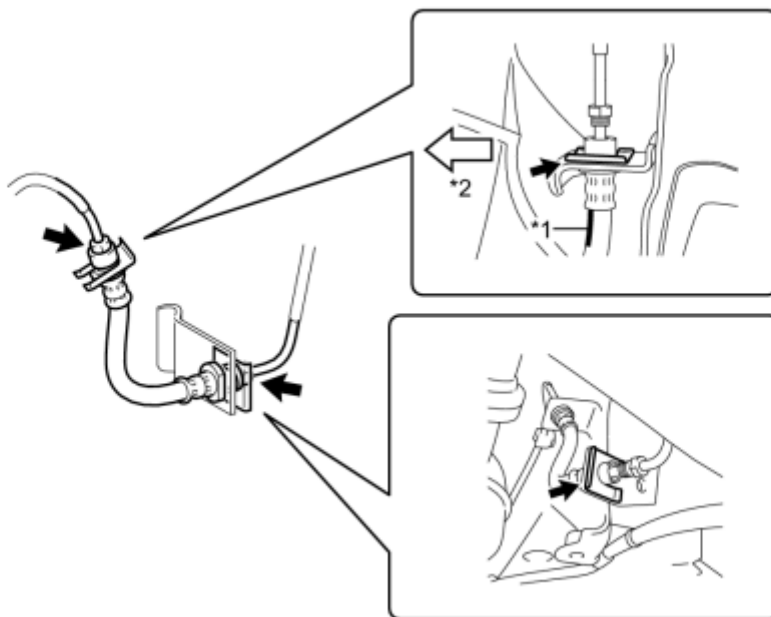

c

### *Text in Illustration*

*1	Identification Mark	*2	Inside of the Vehicle
----	---------------------	----	-----------------------

NOTICE:

- Install the clip as far as it will go.
- When installing the rear brake tube flexible hose, face the identification mark to the inside of the vehicle and minimize twisting of the hose.

(b) Using a union nut wrench, connect the 2 brake lines to the rear brake tube flexible hose.

Torque: **15 N·m (155 kgf·cm, 11ft·lbf)**

NOTICE:



- Do not bend or damage the brake line.
- Do not allow any foreign matter such as dirt and dust to enter the brake line from the connecting points.
- Use the formula to calculate special torque values for situations where the union nut wrench is combined with a torque wrench **INFO**.

### 3. INSTALL REAR FLEXIBLE HOSE



(a) Connect the rear flexible hose to the rear disc brake cylinder assembly with a new union bolt and a new gasket.

Torque: **33 N·m (340 kgf·cm, 25ft·lbf)**



(b) Install a new clip.

NOTICE:

Install the clip as far as it will go.

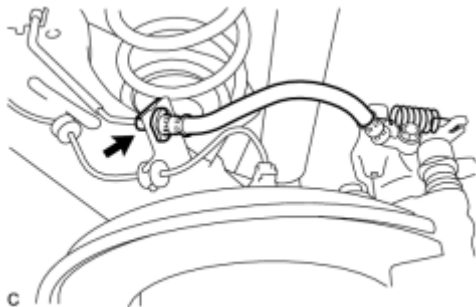

(c) Using a union nut wrench, connect the brake line to the rear flexible hose while holding the rear flexible hose with a wrench.

Torque: **15 N·m (155 kgf·cm, 11ft·lbf)**

- Do not bend or damage the brake line.
- Do not allow any foreign matter such as dirt and dust to enter the brake line from the connecting points.
- Use the formula to calculate special torque values for situations where the union nut wrench is combined with a torque wrench **INFO**.

### 4. BLEED BRAKE LINE **INFO**

### 5. PERFORM INITIALIZATION AND CALIBRATION OF LINEAR SOLENOID VALVE

HINT:

If the brake control has been disabled, make sure to perform initialization and calibration of the linear solenoid valve **INFO**.

### 6. INSTALL REAR WHEEL

Torque: **103 N·m (1050 kgf·cm, 76ft·lbf)**

# COMPONENTS

## ILLUSTRATION

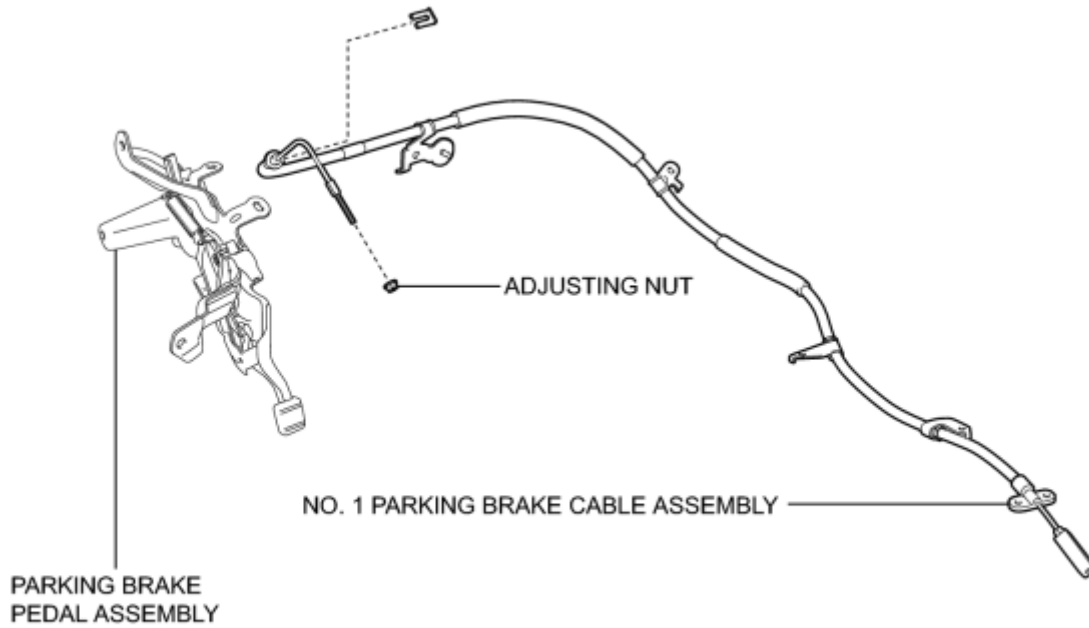

c

## ILLUSTRATION

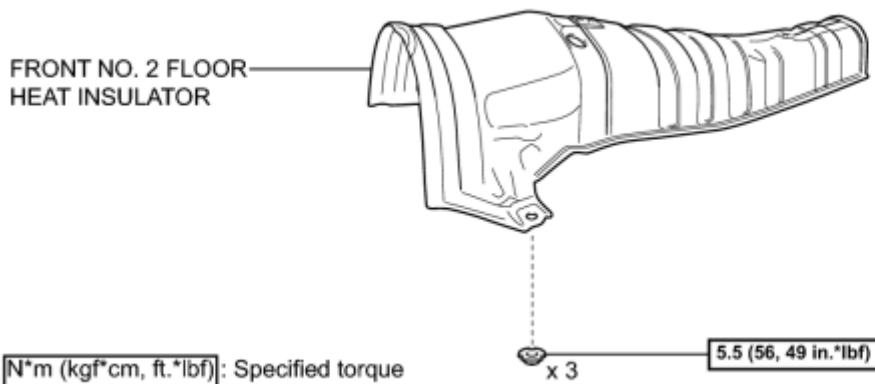

c

## ILLUSTRATION

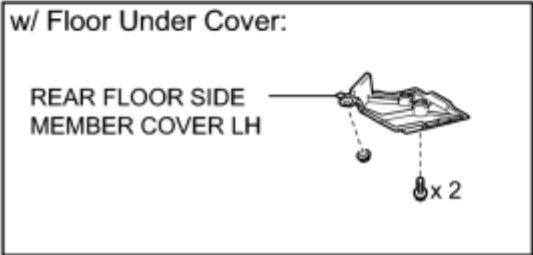
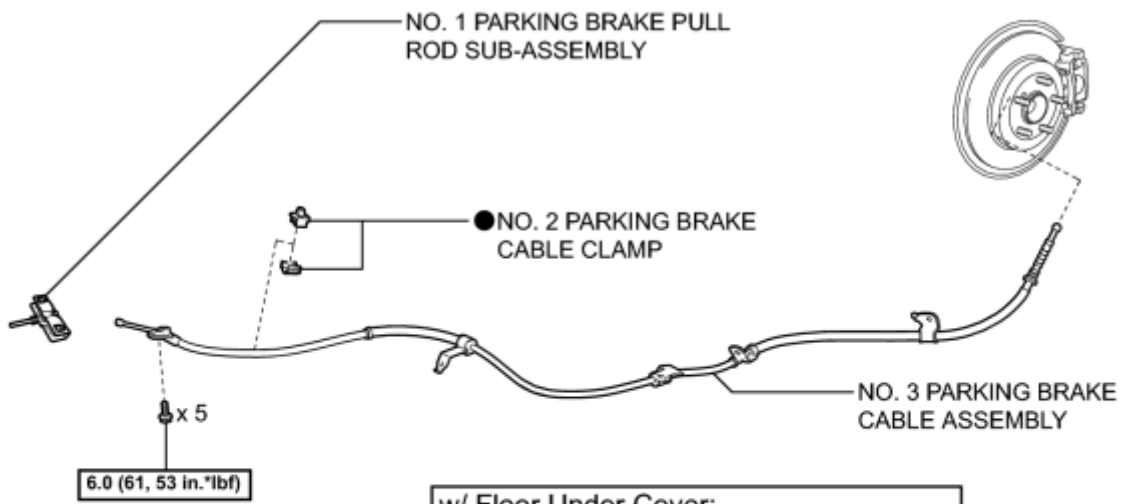

**N\*m (kgf\*cm, ft.\*lbf)**: Specified torque

● Non-reusable part

c

# REMOVAL

## 1. REMOVE REAR WHEEL

## 2. REMOVE PARKING BRAKE CONTROL PEDAL ASSEMBLY

HINT:

Refer to the instructions for Removal of the parking brake control pedal assembly [INFO](#).

## 3. REMOVE NO. 1 PARKING BRAKE CABLE ASSEMBLY

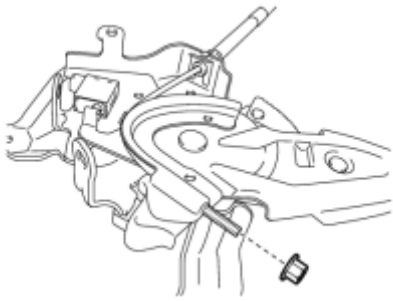

(a) Remove the adjusting nut.

c

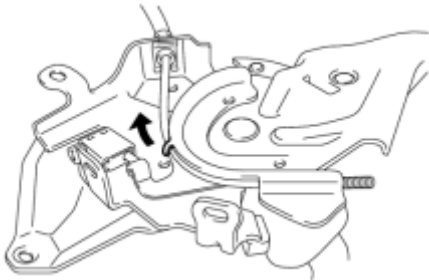

(b) Pull up the parking brake pedal claw.

c

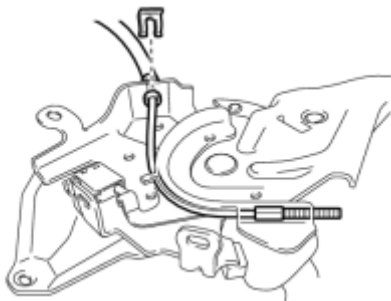

(c) Remove the clip from the No. 1 parking brake cable assembly.

c

(d) Remove the No. 1 parking brake cable assembly from the parking brake pedal assembly.

## 4. REMOVE FRONT EXHAUST PIPE ASSEMBLY

HINT:

Refer to the instructions for Removal of the front exhaust pipe assembly INFO.

#### 5. REMOVE FRONT NO. 2 FLOOR HEAT INSULATOR

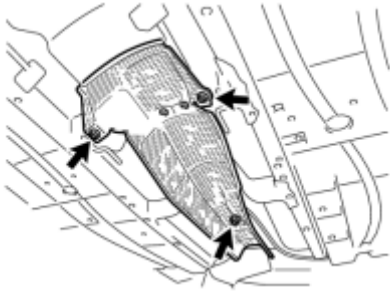

(a) Remove the 3 nuts and front No. 2 floor heat insulator.

#### 6. REMOVE REAR FLOOR SIDE MEMBER COVER LH (w/ Floor Under Cover) INFO

#### 7. REMOVE NO. 1 PARKING BRAKE PULL ROD SUB-ASSEMBLY

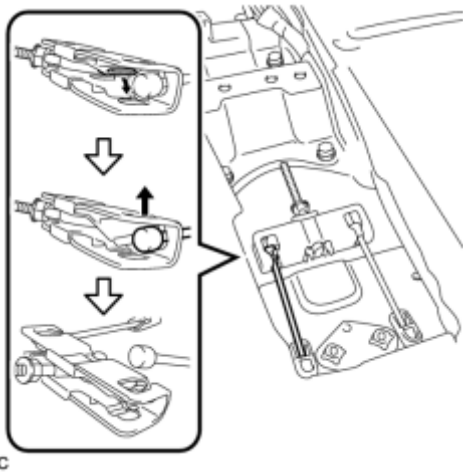

(a) Separate the No. 3 parking brake cable assembly from the No. 1 parking brake pull rod sub-assembly as shown in the illustration.

(b) Separate the No. 2 parking brake cable assembly to remove the No. 1 parking brake pull rod sub-assembly.

**HINT:**

Perform the same procedure as for the No. 3 parking brake cable assembly.

#### 8. REMOVE NO. 3 PARKING BRAKE CABLE ASSEMBLY

(a) Disengage the clamp to separate the No. 2 parking brake cable clamp.

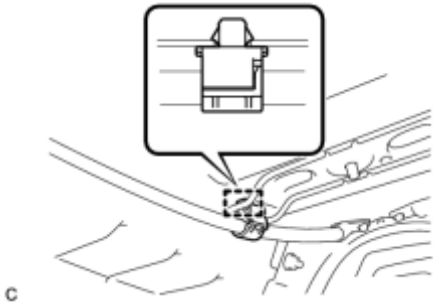

(b) Separate the No. 3 parking brake cable assembly from the rear disc brake cylinder assembly.

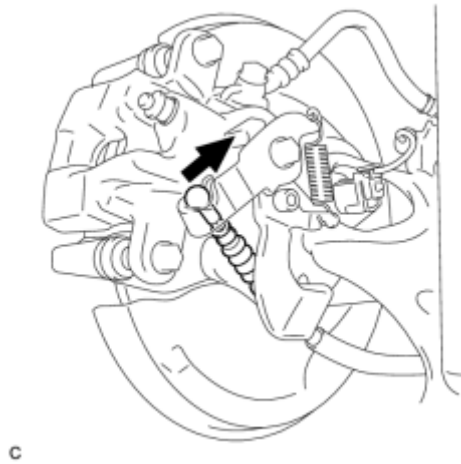

(c) Disconnect the No. 3 parking brake cable assembly from the rear disc brake cylinder assembly.

### Text in Illustration

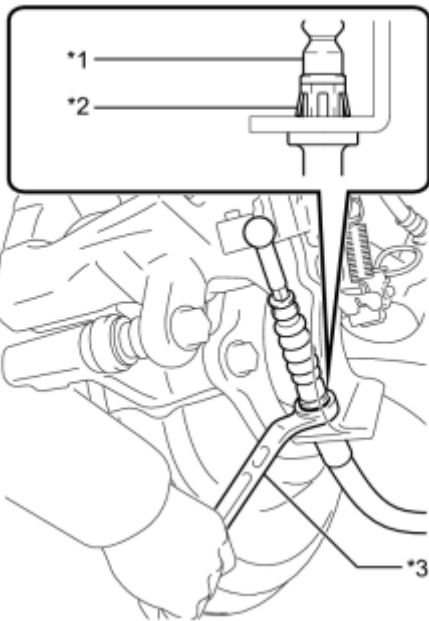

*1	No. 3 Parking Brake Cable Assembly
*2	Clip
*3	Offset Wrench (14 mm)

### HINT:

Insert an offset wrench (14 mm) at the base of the No. 3 parking brake cable assembly as shown in the illustration to disengage the clip. Pull out the No. 3 parking brake cable assembly from the rear disc brake cylinder assembly.

(d) Remove the 5 bolts and No. 3 parking brake cable assembly.

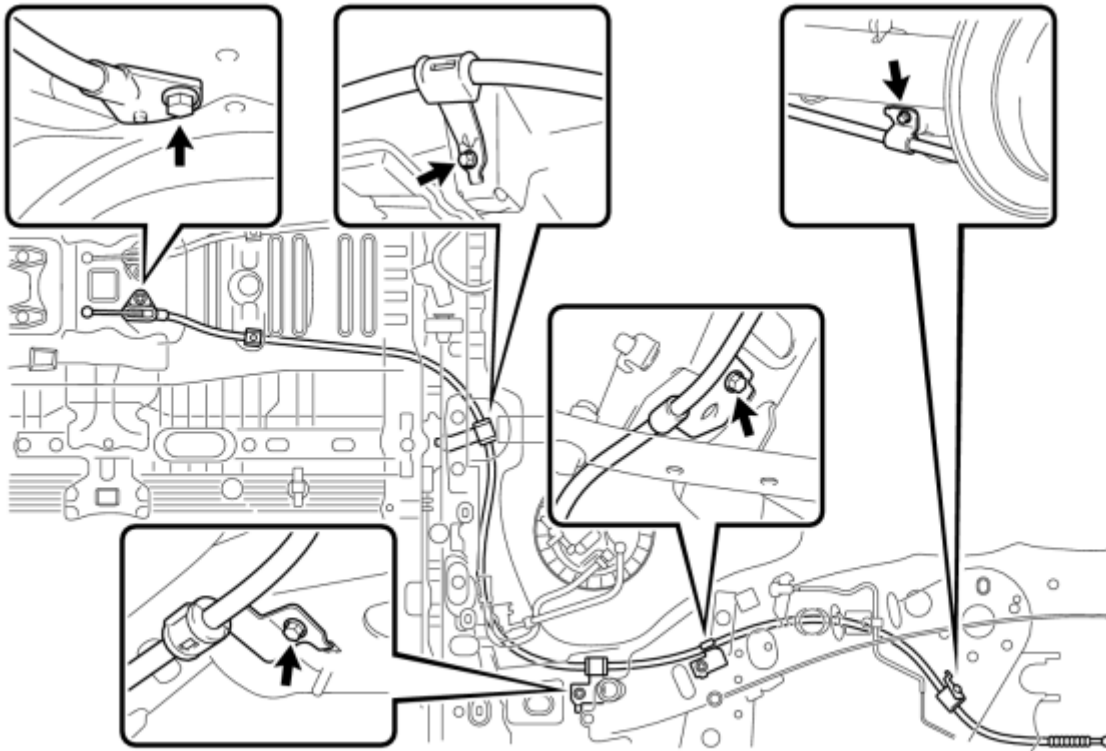

c

9. REMOVE NO. 2 PARKING BRAKE CABLE CLAMP

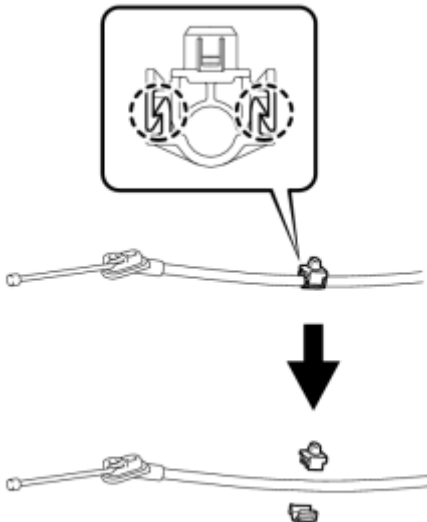

(a) Disengage the 2 claws to remove the No. 2 parking brake cable clamp from the No. 3 parking brake cable assembly.

P



# INSTALLATION

## 1. INSTALL NO. 2 PARKING BRAKE CABLE CLAMP

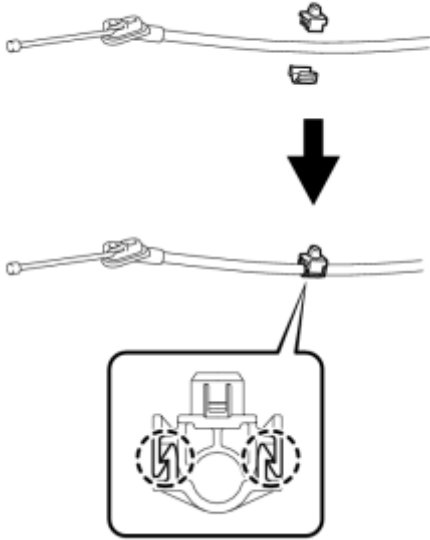

(a) Engage the 2 claws to install a new No. 2 parking brake cable clamp to the No. 3 parking brake cable assembly.

P

## 2. INSTALL NO. 3 PARKING BRAKE CABLE ASSEMBLY

(a) Install the No. 3 parking brake cable assembly with the 5 bolts.

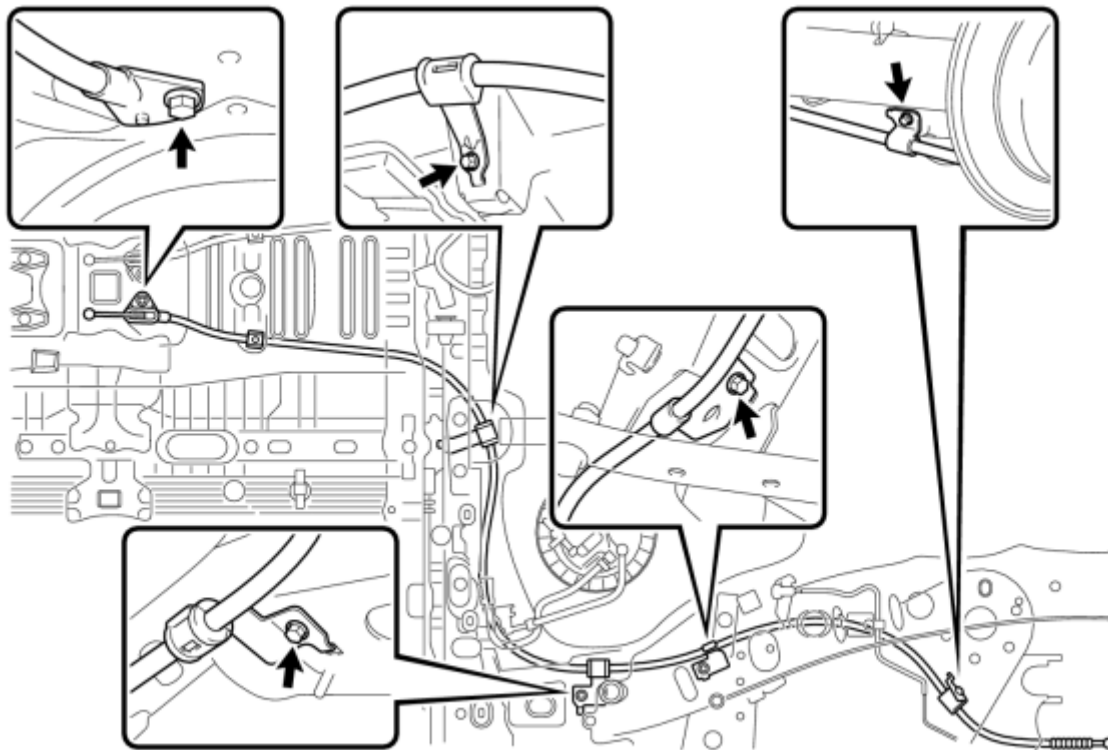

c

Torque: 6.0 N·m (61 kgf·cm, 53in·lbf)

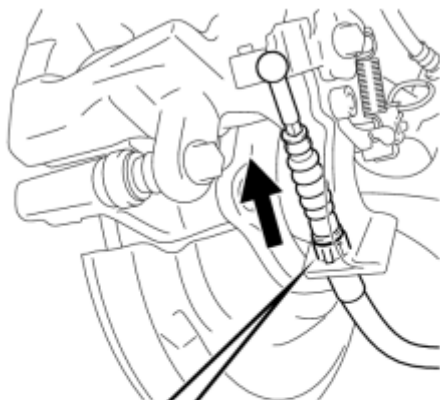

(b) Install the No. 3 parking brake cable assembly to the rear disc brake cylinder assembly.

### Text in Illustration

*1	No. 3 Parking Brake Cable Assembly
*2	Clip

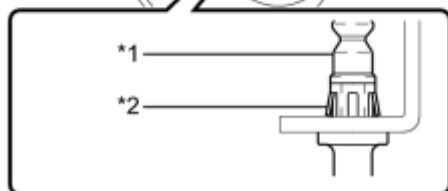

HINT:

Be sure to engage the No. 3 parking brake cable assembly clip onto the rear disc brake cylinder assembly as shown in the illustration.

c

(c) Connect the No. 3 parking brake cable assembly to the rear disc brake cylinder assembly.

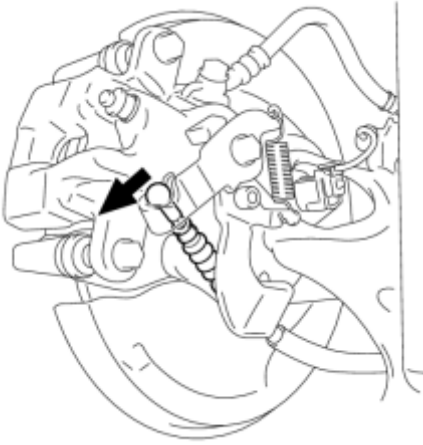

c

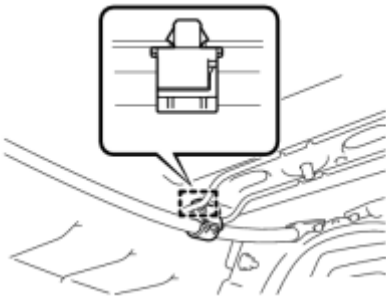

c

(d) Engage the clamp to install the No. 2 parking brake cable clamp.

3. INSTALL REAR FLOOR SIDE MEMBER COVER LH (w/ Floor Under Cover) INFO

4. INSTALL FRONT NO. 2 FLOOR HEAT INSULATOR

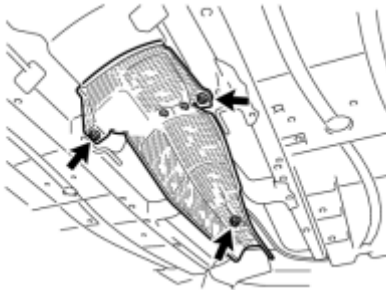

c

(a) Install the front No. 2 floor heat insulator with the 3 nuts.

Torque: **5.5 N·m (56 kgf·cm, 49in·lbf)**

5. INSTALL FRONT EXHAUST PIPE ASSEMBLY

HINT:

Refer to the instructions for Installation of the front exhaust pipe assembly INFO.

6. INSTALL NO. 1 PARKING BRAKE PULL ROD SUB-ASSEMBLY

(a) Connect the No. 3 parking brake cable assembly to the No. 1 parking

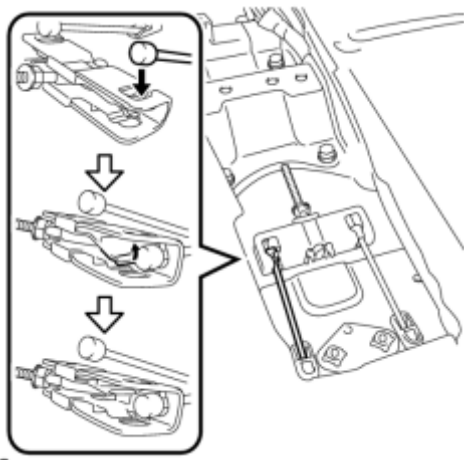

brake pull rod sub-assembly as shown in the illustration.

c

(b) Connect the No. 2 parking brake cable assembly to the No. 1 parking brake pull rod sub-assembly.

HINT:

Perform the same procedure as for the No. 3 parking brake cable assembly.

## 7. INSTALL NO. 1 PARKING BRAKE CABLE ASSEMBLY

(a) Pass the No. 1 parking brake cable assembly through the parking brake pedal assembly.

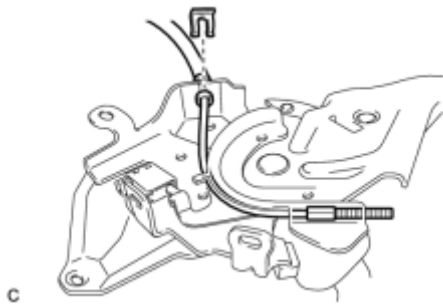

c

(b) Install the clip to the No. 1 parking brake cable assembly.

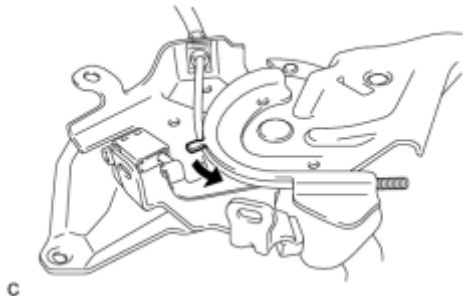

c

(c) Bend the parking brake pedal claw.

(d) Temporarily install the adjusting nut.

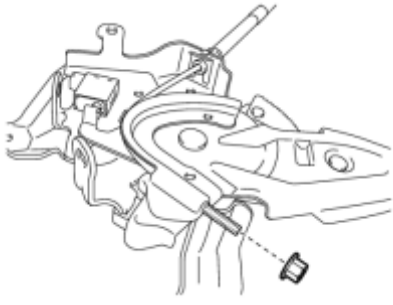

## 8. INSTALL PARKING BRAKE CONTROL PEDAL ASSEMBLY

### HINT:

Refer to the instructions for Installation of the parking brake control pedal assembly INFO.

## 9. INSTALL REAR WHEEL

Torque: **103 N·m (1050 kgf·cm, 76ft·lbf)**

# COMPONENTS

# ILLUSTRATION

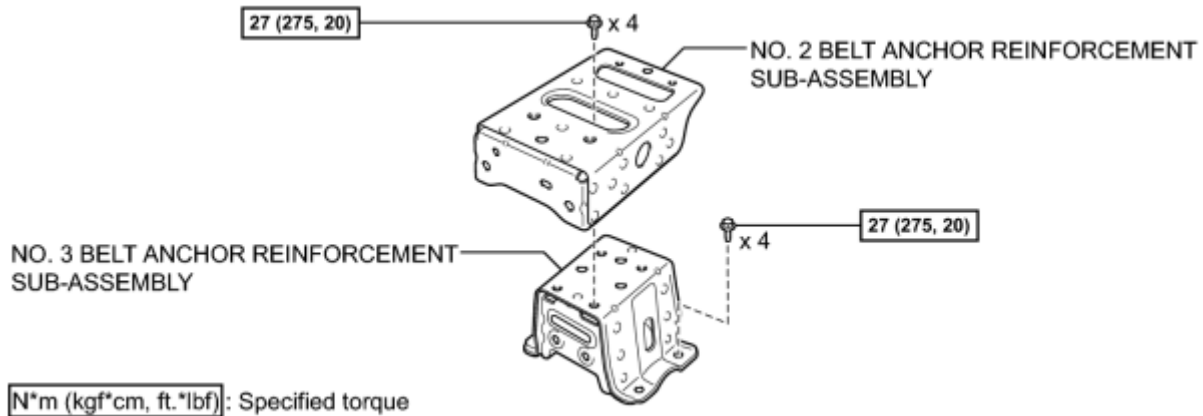

c

# ILLUSTRATION

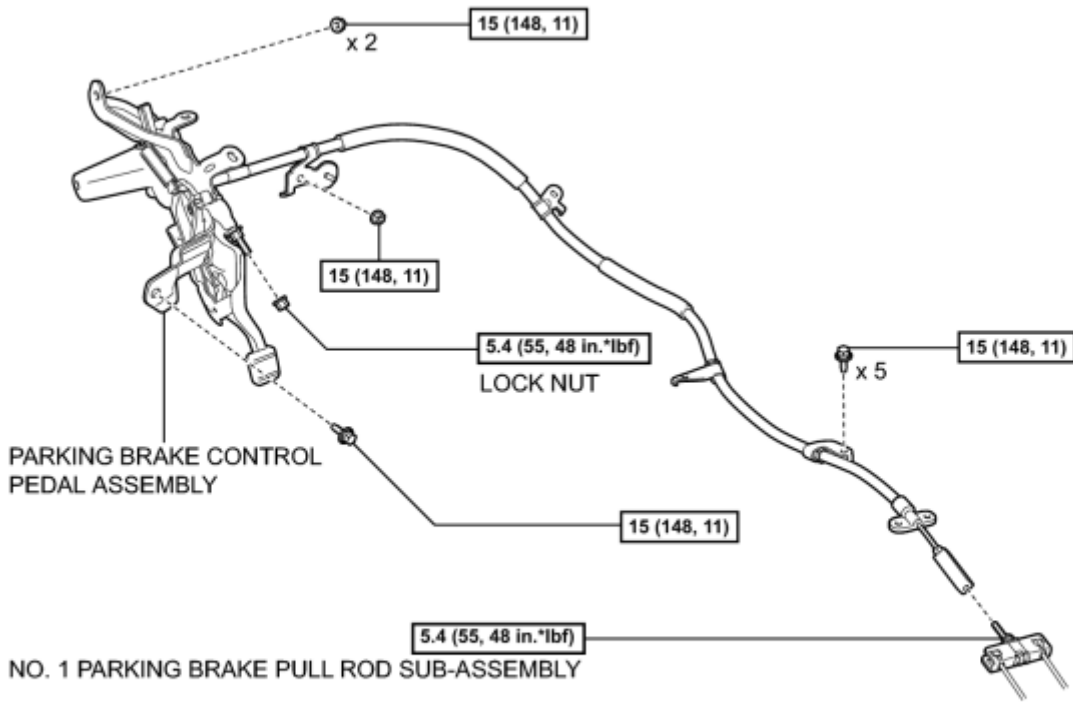

**N\*m (kgf\*cm, ft.\*lbf)**: Specified torque

c

## ILLUSTRATION

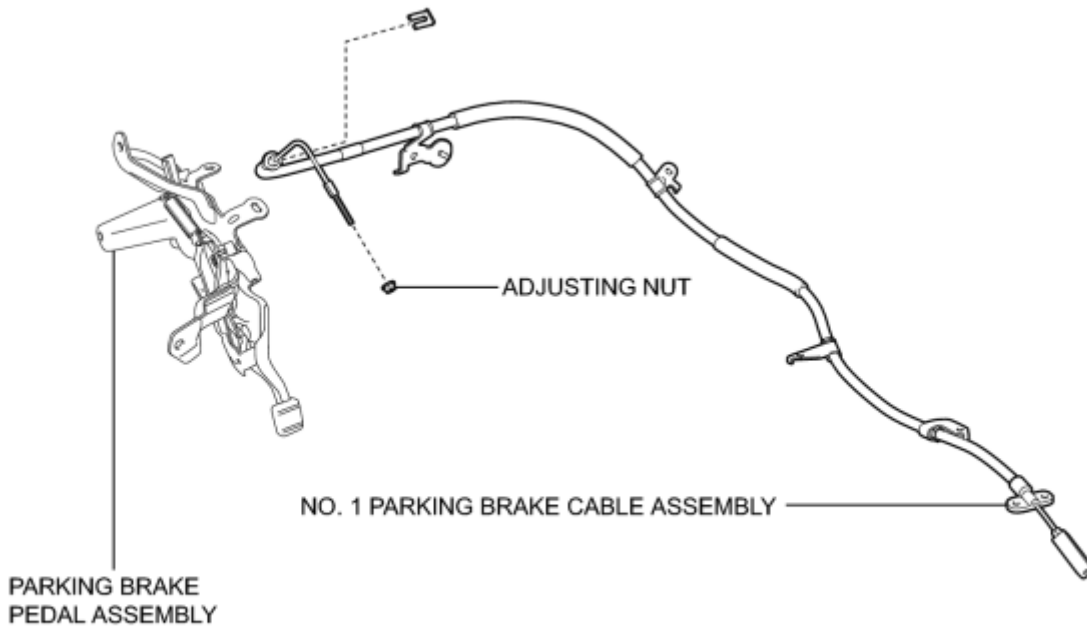

c

## ILLUSTRATION

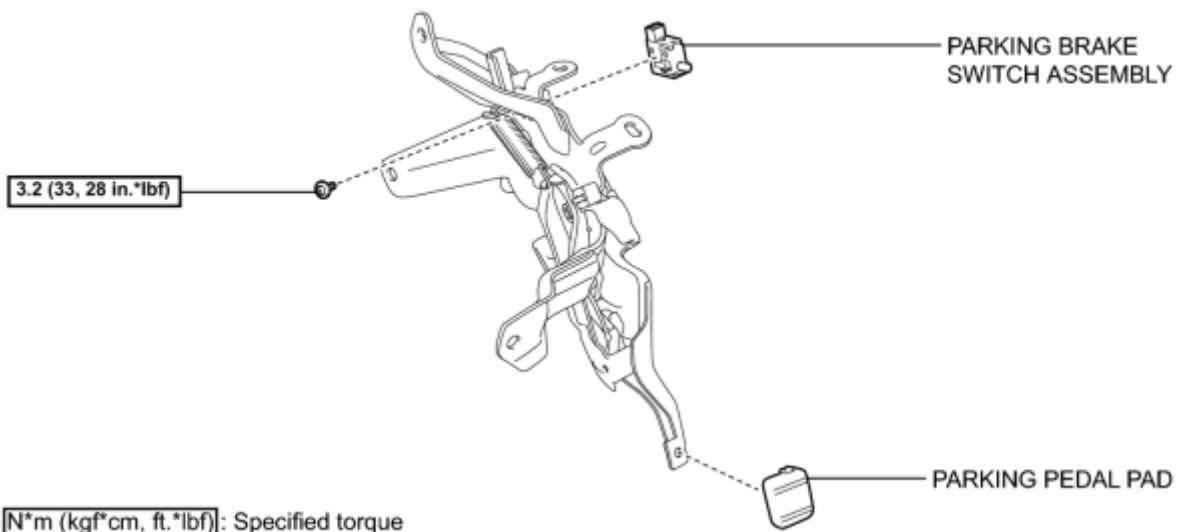

c