



Technical Service BULLETIN

October 9, 2003

Title:

MAINTENANCE FOR HV AND AUXILIARY BATTERIES

Models:

'04 - '05 Prius

REVISED

PG007-03

PRODUCT GENERAL INFORMATION

TSB REVISION NOTICE:

September 16, 2004: 2005 model year has been added to Applicable Vehicles. The previous TSB should be discarded.

Introduction The 2004 - 2005 model year Prius hybrid vehicle is equipped with 2 types of special batteries, the HV (Hybrid Vehicle) battery and the 12-volt auxiliary battery.

If the hybrid vehicle is put into storage, the state of charge (SOC) of its HV battery and auxiliary battery will gradually decrease. To prevent the battery from deteriorating during storage, proper maintenance is necessary.

Therefore, please perform the following maintenance service for the HV battery and 12-volt auxiliary battery.

Maintenance Items at Port of Entry and Dealership:

CONDITION		MAINTENANCE OPERATION
A	Just after unloading and then every two months	Keep "Hybrid System" on for 30 minutes. (In order to charge the HV battery and the auxiliary battery.)
B	Before delivery	Fully charge 12-volt auxiliary battery using the Prius Automatic Charger (P/N 00002-YA122-01). (Deliver vehicle to customer only after it is fully charged.)
C	In order to store for 10 days or more	Disconnect wire harness from exclusive jump starting terminal (found in Junction Block under hood). (Prevent decreasing SOC during storage due to parasitic current.)

Applicable Vehicles



- 2004 - 2005 model year Prius vehicles.

Warranty Information

OP CODE	DESCRIPTION	TIME	OFF	T1	T2
N/A	Not Applicable to Warranty	-	-	-	-

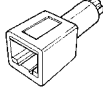

**Required
SSTs**

SPECIAL SERVICE TOOLS (SSTs)	PART NUMBER	QUANTITY
Midtronics Battery Tester* 	00002-MP815-T	1
Midtronics Battery Tester Adapter* 	00002-DMPUC	1
Prius Automatic Charger** 	00002-YA122-01	1

* Essential SSTs.

** Supercedes 00002-YA121-01. P/N 00002-YA121-01 may still be used (with switch in 10 AMP position).

Maintenance
Operation:
Condition A

Just After Unloading and Then Every Two Months

NOTE:

The 12-volt auxiliary battery is charged by the HV battery whenever the “READY” light is on, regardless of the gasoline engine operation.

1. Park the vehicle in open air area or connect an exhaust extraction hose to the exhaust pipe.
2. Apply the parking brake.
3. Make sure the key is fully inserted into the key slot.

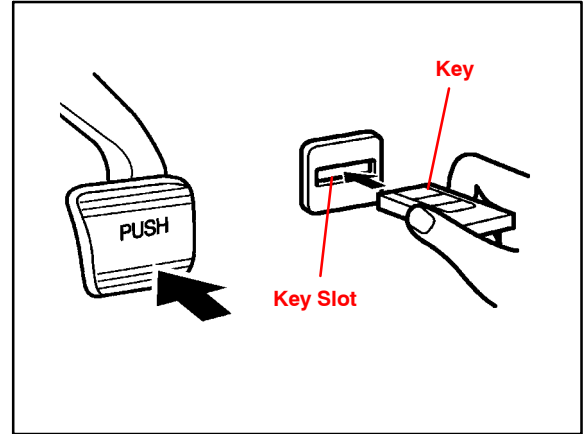

4. With the brake pedal depressed, press the “POWER” switch and check that the “READY” light in the meter illuminates. When the hybrid system starts (the “READY” light is on).
5. Turn off all lights and accessories.
6. Check that the shift selector is in the “P” position.

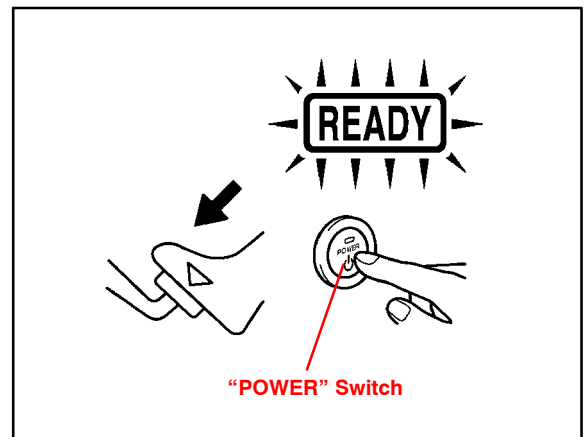

7. Keep the “READY” light on for 30 minutes, charging the HV battery.

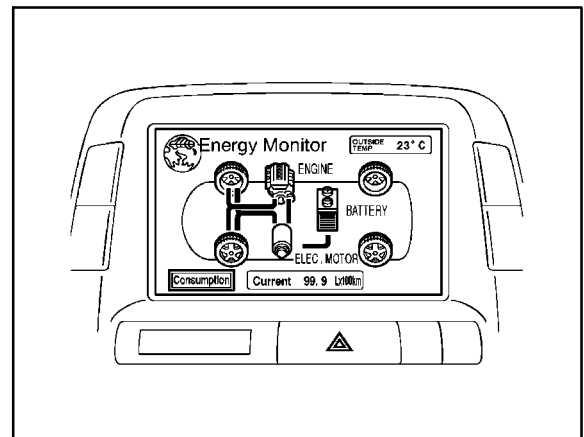

Maintenance Operation: Condition B Before Delivery

NOTE:

- Before you disconnect the auxiliary battery, confirm the shift position is in the “P” position and apply the parking brake completely.
- While the auxiliary battery is disconnected, the back door latch will not operate using the handle on the outside of the door. To open the door, pull the security opener in the luggage storage box. For details, refer to the Owner’s Manual.

1. Remove the auxiliary battery.
 - A. Turn off all lights and accessories.
 - B. Open the back door.
 - C. Remove the rear deck cover.
 - D. Remove the deck under tray and auxiliary battery cover.

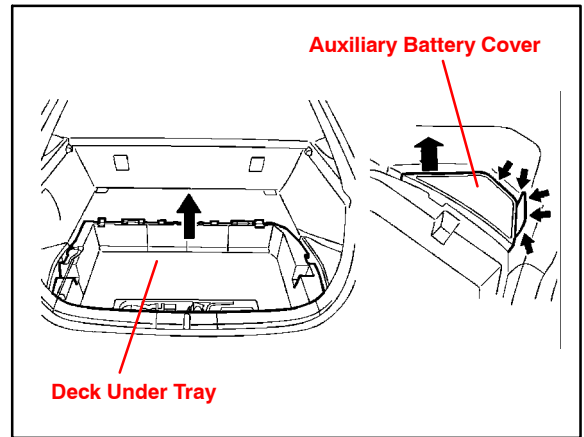

- E. Remove the positive terminal cover.
 - F. Disconnect the two connectors from the positive terminal block and the connector to the brake system’s power source back-up unit.
 - G. Remove the HV battery vent duct.
 - H. Disconnect the negative terminal and then the positive terminal.
 - I. Disconnect the vent hose.

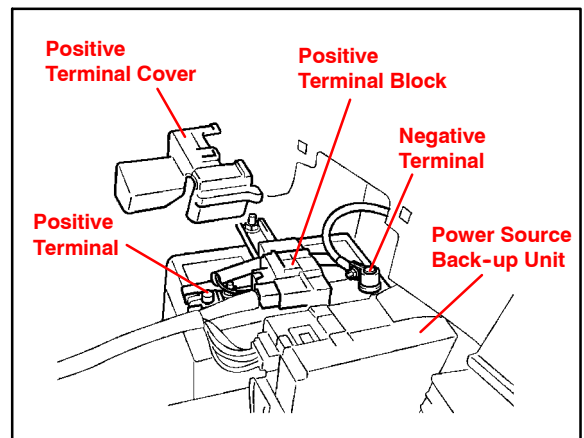

NOTE:
The plastic elbow pulls straight out of the battery case - do not twist.

- J. Remove the hold-down clamp and auxiliary battery.

Maintenance Operation: Condition B
(Continued)

2. Charge the 12-volt auxiliary battery.

CAUTION:

- Do not charge with the battery mounted in the vehicle.
- Charge in a well-ventilated area.
- Do not allow sparks or fire near the battery.

A. Obtain the Prius Automatic Charger (SST P/N 00002-YA122-01*).

* Supercedes P/N 00002-YA121-01. P/N 00002-YA121-01 may still be used (with switch in 10 AMP position).

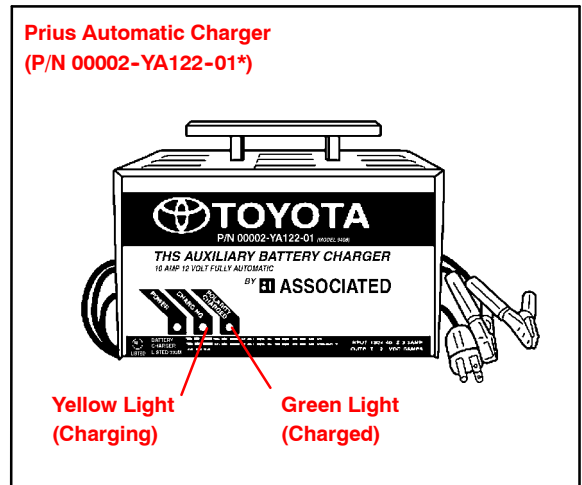

NOTE IF USING P/N 00002-YA121-01:

Ensure that the charge current switch is set on the 10 AMP position. When operated in the 10 AMP position, the Prius Automatic Charger (SST P/N 00002-YA121-01) is designed to automatically regulate charging current and voltage. Using this mode, the charger will minimize charge time, while preventing overheating and possible battery damage. Charging in the 2 AMP position is not recommended for the Prius 12-volt battery, due to prolonged charge time.

CAUTION:

Use of standard battery chargers is NOT recommended on the Prius 12-volt auxiliary battery, in order to prevent battery damage.

- B. Connect the red charger clamp to the positive battery terminal and the black charger clamp to the negative battery terminal.
- C. Plug the charger into a grounded 110V nominal outlet and verify the RED "POWER" light is on.

NOTE:

The Prius 12-volt auxiliary battery charger (SST P/N 00002-YA122-01) control tests for correct polarity before applying current to the battery (a built-in safety feature). When connected properly, the GREEN light will come on for 2 seconds before the YELLOW light comes on. If no lights come on, check for proper connection and/or a dead battery.

- D. Once the charger is properly connected, the YELLOW light indicates the battery is charging.
- E. The battery is charged once the GREEN light comes on.

NOTE:

The GREEN charged light and YELLOW charging light will switch back and forth once the battery is at 80% state of charge. At this point the battery is charged and may be returned to the vehicle. If you continue charging, the switching between YELLOW (charging) and GREEN (charged) will slow until the GREEN (charged) light stays on continuously at 100% state of charge.

Maintenance Operation: Condition B
(Continued)

3. If the Prius Automatic Charger is not available, you may charge the 12-volt battery by turning the vehicle on to "READY."
 - Run time will vary depending on the state of charge.
 - If this method is used you must confirm that the battery is charged to 12.8 volts using a DVOM or Midtronics Battery Tester after removing the surface charge.

NOTE:
If the engine has been running before measuring the voltage, turn on head lamps for 60 seconds. Then wait 60 seconds to take measurement. This removes the surface charge.

4. Test Auxiliary Battery (if necessary).
 - A. Test battery using the Midtronics Tester (SST P/N 00002-MP815-T.) Please refer to the Technical Information System (TIS) for the current STK#.
 - From the first TIS screen, select "Diagnostics," then
 - "Midtronics Battery Tester Software," then
 - "Toyota Stock Number Chart."

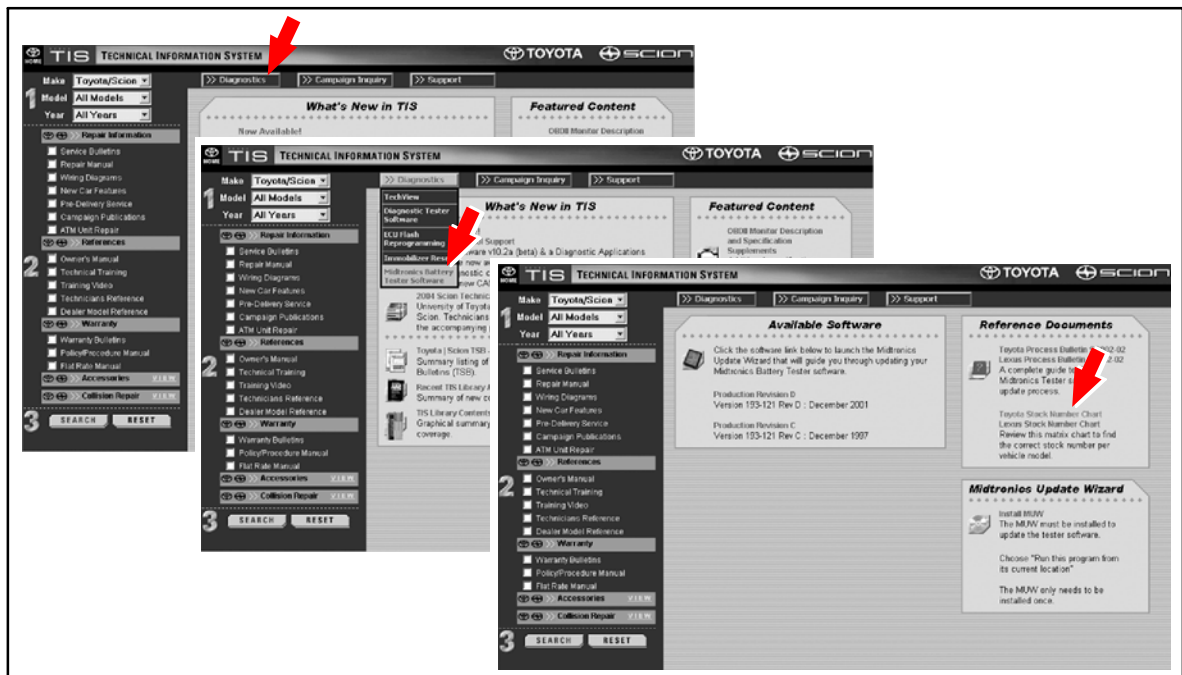

- B. If the Midtronics Tester indicates to replace the battery, order the appropriate Toyota Genuine Battery, P/N 28800-21050.
- C. The Prius auxiliary battery is not part of the TrueStart™ Replacement Program.

CAUTION:
The Prius auxiliary battery is a special Valve Regulated Absorbed Glass Mat (AGM) design and should NEVER be replaced with a conventional battery design.

Maintenance Operation: Condition B
(Continued)

5. Install the auxiliary battery.
 - A. Place the auxiliary battery in the correct position and install the hold-down clamp.
 - B. Connect the vent hose.
 - C. Connect the positive terminal first, and then the negative terminal.
Torque: 6.0 N•m (61 kgf•cm, 4.4 ft•lbf)
 - D. Install HV battery vent duct.
 - E. Reconnect harness to positive terminal block and power source back-up unit.
 - F. Install the positive terminal cover.
 - G. Install the auxiliary battery cover and the deck under tray.
 - H. Install the deck cover.
 - I. Close the back door.

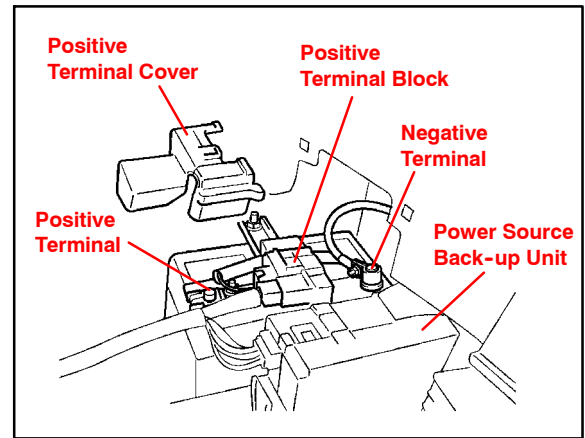

Maintenance Operation: Condition C

In Order to Store for 10 Days or More

1. Disconnect the wire harness from the exclusive jump starting terminal.
 - A. Turn off all lights and accessories.
 - B. Open the hood and remove the relay block cover.
 - C. Open the cover (red) for the exclusive jump starting terminal.
 - D. Use a 10 mm long socket to remove the nut.

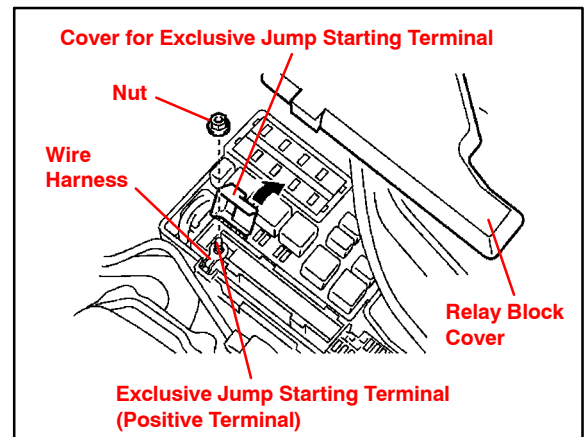

NOTE:
When removing or installing the nut and wire harness, do not touch the inverter or other parts, as it may cause electrical system damage.

Maintenance Operation: Condition C
(Continued)

- E. Use needle-nose pliers to pull up the wire harness from the exclusive jump starting terminal (positive terminal).
- F. Temporarily install the nut on the exclusive jump starting terminal.
- G. Close the cover for the exclusive jump starting terminal, and place the wire harness on the cover.
- H. After closing the relay block cover, close the hood.

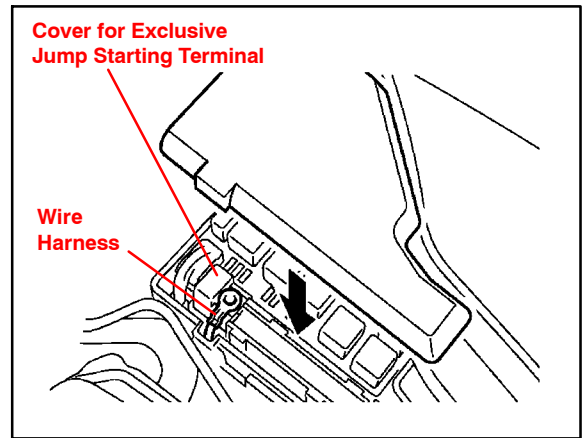

HINT:
If the negative terminal of the battery is reconnected, even if the "POWER" switch is pressed once while depressing the brake pedal, the hybrid system may not start. At this time, the "READY" light is off. In this case, press the "POWER" switch again to start the hybrid system (the "READY" light is on). If the hybrid system still does not start (the "READY" light is off), refer to the Repair Manual.

2. Connect the wire harness.

HINT:
After reconnecting the auxiliary battery, the power window must be initialized. For details, refer to TSB No. PD010-03, "Pre-Delivery Service (PDS) Information for Prius."

- A. Open the hood and remove the relay block cover.
- B. Open the cover for the exclusive jump starting terminal.
- C. Remove the temporarily installed nut, and after installing the wire harness on the exclusive jump starting terminal, securely tighten the nut.
Torque: 6.8-9.8 N•m (69-100 kgf•cm, 5.0-7.2 ft•lbf)
- D. Close the cover for the exclusive jump starting terminal.
- E. After closing the relay block cover, close the hood.

