

IGNITION SYSTEM

PARTS LOCATION

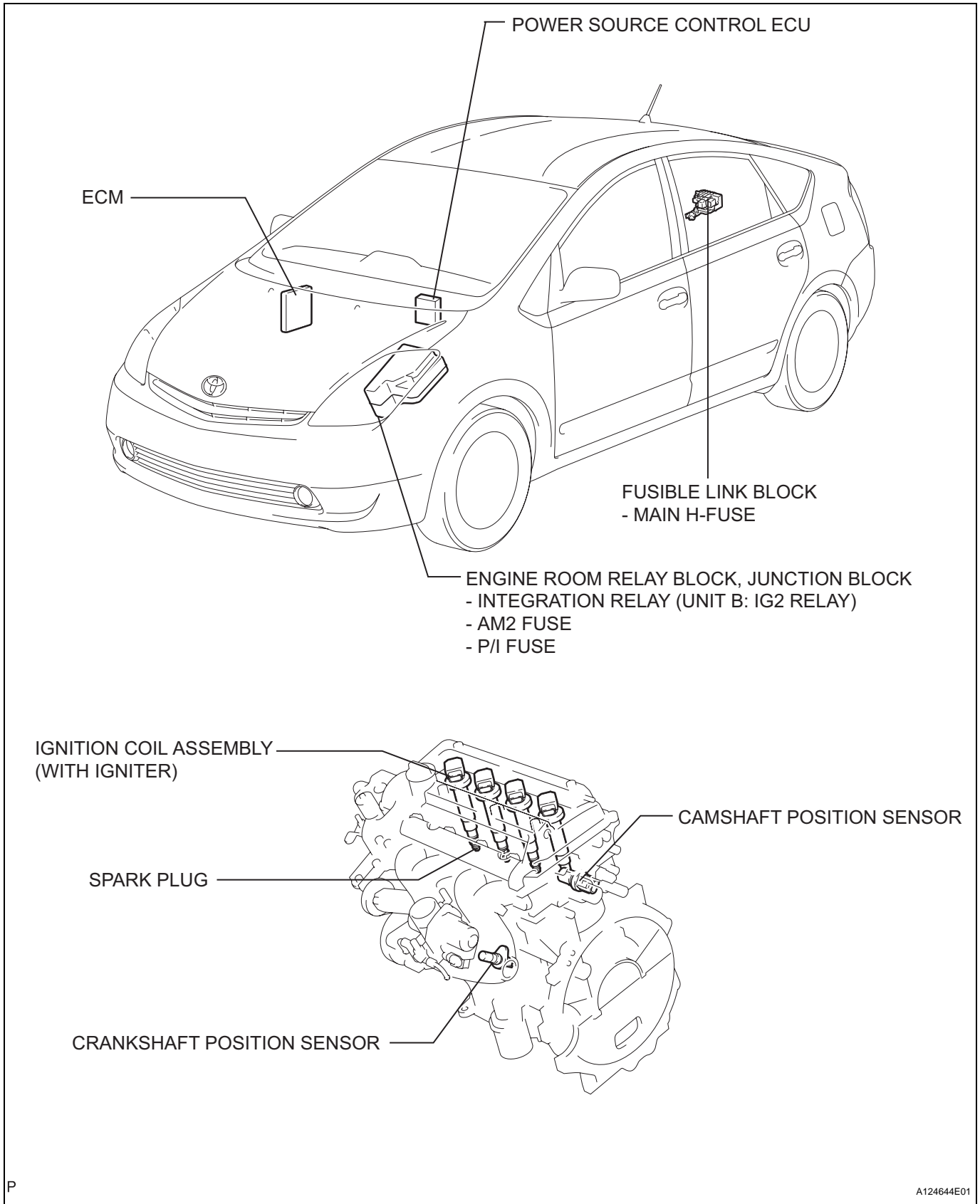

SYSTEM DIAGRAM

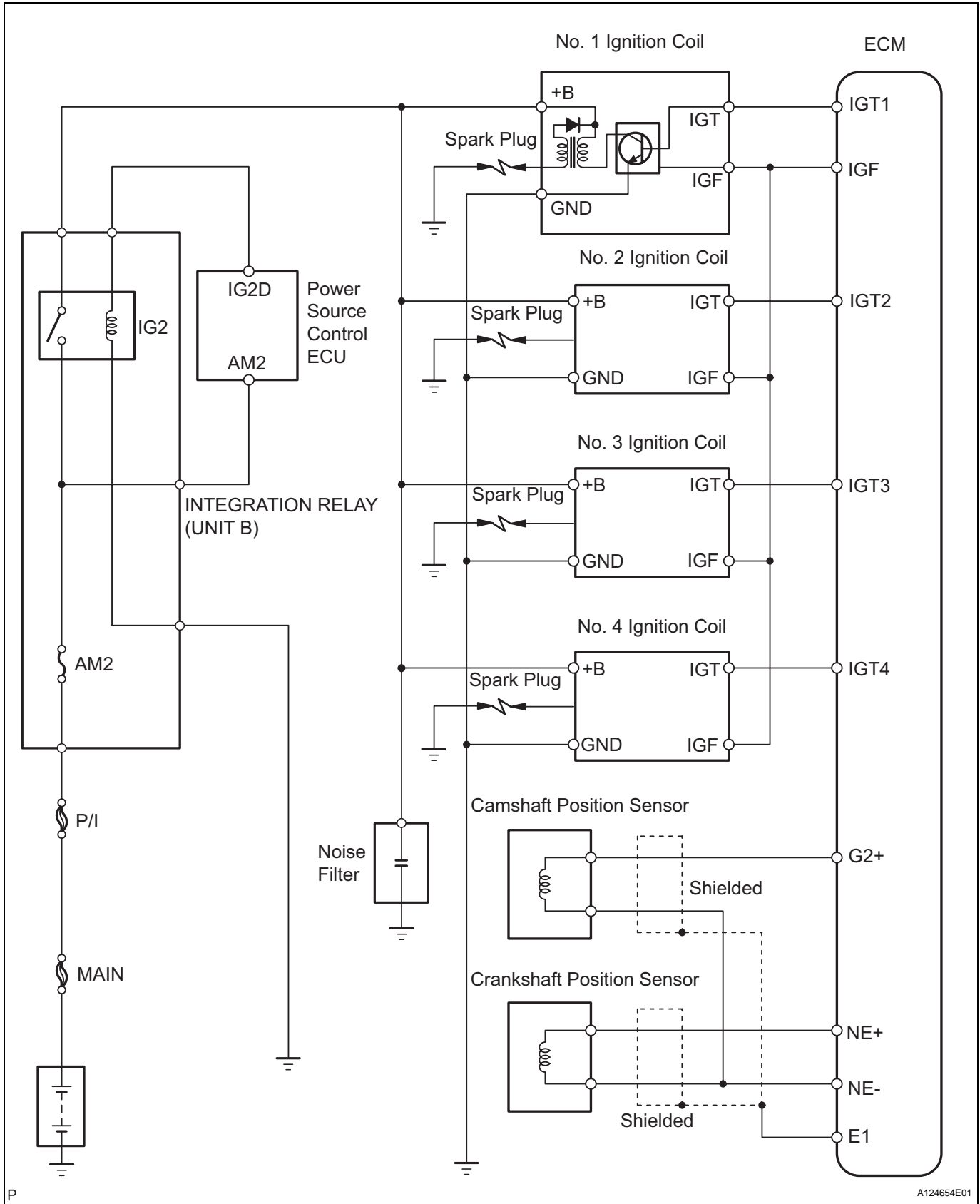

ON-VEHICLE INSPECTION

NOTICE:

In this section, the terms "cold" and "hot" refer to the temperature of the coils. "Cold" means approximately -10 to 50°C (14 to 122°F). "Hot" means approximately 50 to 100°C (122 to 212°F).

1. PERFORM SPARK TEST

- (a) Check for DTCs (see page [ES-29](#)).

NOTICE:

If a DTC is present, perform troubleshooting in accordance with the procedure for that DTC.

- (b) Check that sparks occur.
- (1) Remove the ignition coil (see page [IG-8](#)).
 - (2) Disconnect the 4 fuel injector connectors.

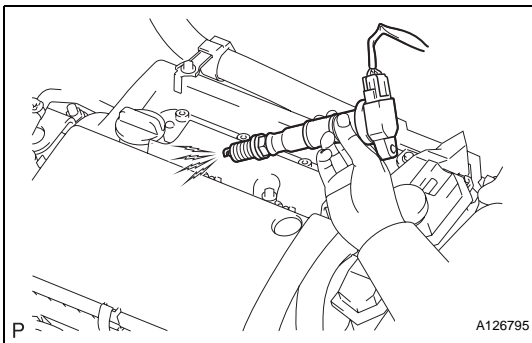
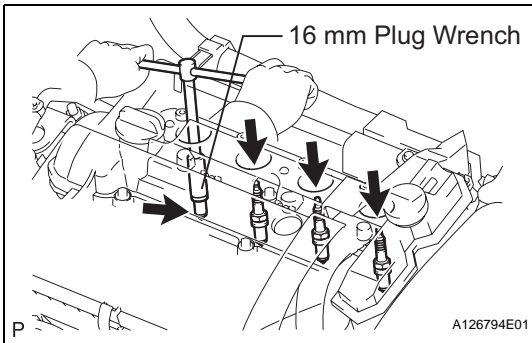
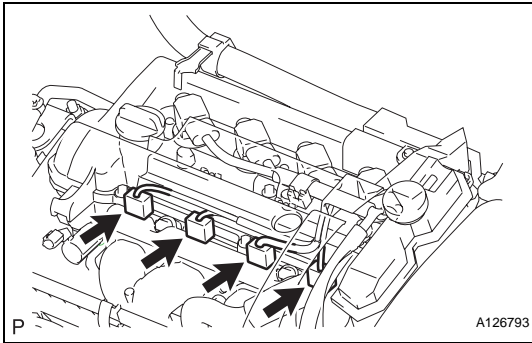

- (3) Using a 16 mm plug wrench, remove the 4 spark plugs.

Torque: 18 N*m (184 kgf*cm, 13 ft.*lbf)

- (4) Install each spark plug into an ignition coil, then connect the ignition coil connectors.
- (5) Ground the spark plug.
- (6) Check that sparks occur at each spark plug while the engine is being cranked.

NOTICE:

- **Be sure to ground the spark plugs when checking them.**
- **If the ignition coil has been struck or dropped, replace it.**
- **Do not crank the engine for more than 2 seconds.**

If sparks do not occur, perform the following procedure.

(c) Spark test flow chart.

- (1) Check that the wire harness side connector of the ignition coil is securely connected.

Result

Result	Proceed to
NG	Connect securely
OK	Go to next step

- (2) Perform the spark test on each ignition coil.
 1. Replace the ignition coil with a normal one.
 2. Perform the spark test again.

Result

Result	Proceed to
OK	Replace ignition coil
NG	Go to next step

- (3) Check power supply to the ignition coil.
 1. Disconnect the ignition coil connector.
 2. Turn the ignition switch ON.
 3. Using a voltmeter, measure the voltage between the terminals.

Standard voltage

Tester Connection	Specified Condition
1 (+B) - 4 (GND)	9.0 to 14 V

Result

Result	Proceed to
NG	Check wire harness and connector (Between power switch and ignition coil assembly)
OK	Go to next step

- (4) Check the resistance of the camshaft position sensor.

Standard resistance

Temperature	Specified Condition
Cold	1,630 to 2,740 Ω
Hot	1,060 to 1,645 Ω

Result

Result	Proceed to
NG	Replace camshaft position sensor
OK	Go to next step

- (5) Check the resistance of the crankshaft position sensor.

Standard resistance

Temperature	Specified Condition
Cold	985 to 1,600 Ω
Hot	1,265 to 1,890 Ω

Result

Result	Proceed to
NG	Replace crankshaft position sensor

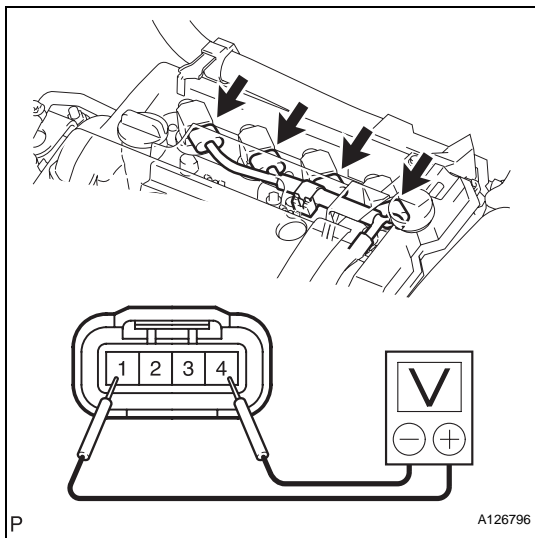

Result	Proceed to
OK	Go to next step

(6) Check IGT signal from the ECM.

Result

Result	Proceed to
NG	Replace ECM
OK	Repair wire harness or connector (Between ignition coil assembly and ignition switch)

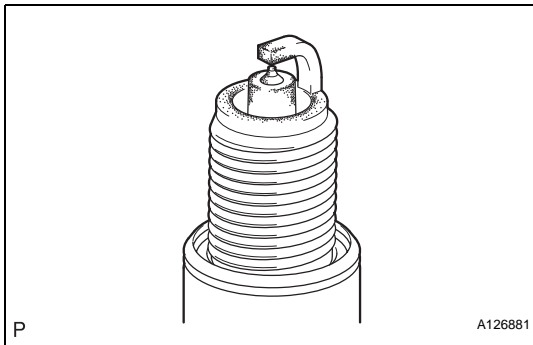
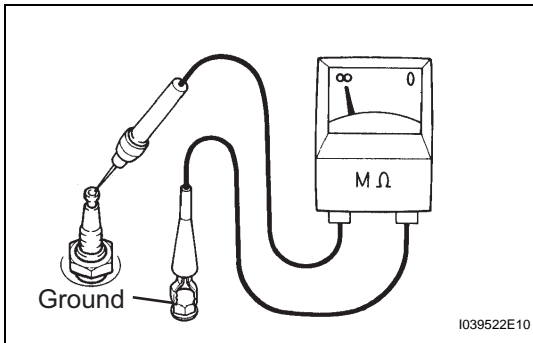

2. CHECK SPARK PLUG

(a) Check the electrode.

(1) Using a megohmmeter, measure the insulation resistance.

Standard insulation resistance:

10 MΩ or more

HINT:

- If a megohmmeter is not available, perform the following simple inspection instead.
- If the result is 10 MΩ or less, clean the plug and measure the resistance again.

(b) Alternative inspection method:

- (1) Quickly accelerate the engine to 4,000 rpm 5 times.
- (2) Remove the spark plug.
- (3) Visually check the spark plug.
If the electrode is dry, the spark plug is functioning properly. If the electrode is damp, proceed to the next step.

(c) Check the spark plug for any damage on its thread and insulator.

If there is damage, replace the spark plug.

Recommended spark plug

Manufacturer	Product
DENSO	SK16R11
NGK	IFR5A11

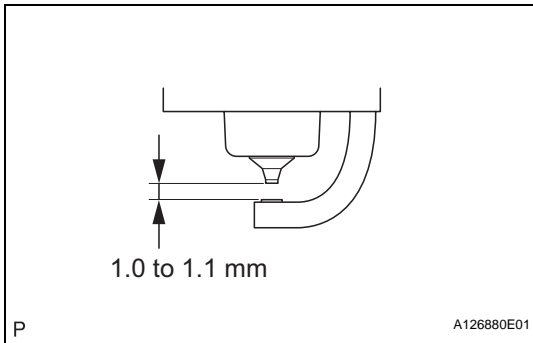

(d) Check the spark plug electrode gap.

Maximum electrode gap for used spark plug:

1.3 mm (0.051 in.)

If the gap is greater than the maximum, replace the spark plug.

Electrode gap for new spark plug:

1.0 to 1.1 mm (0.039 to 0.043 in.)

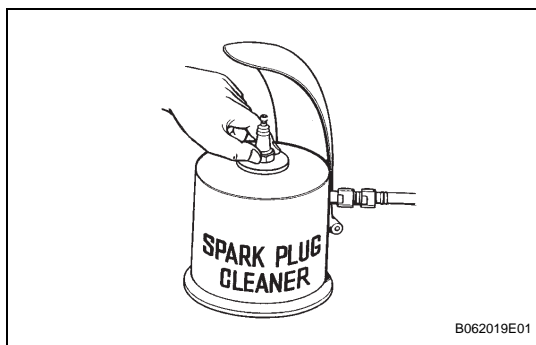

- (e) Clean the spark plugs.
If the electrode has traces of wet carbon, clean the electrode with a spark plug cleaner and then dry it.

Standard air pressure:

588 kPa (6 kgf*cm², 85 psi)

Standard duration:

20 seconds or less

HINT:

Only use the spark plug cleaner when the electrode is free of oil. If the electrode has traces of oil, use gasoline to clean off the oil before using the spark plug cleaner.

IGNITION COIL COMPONENTS

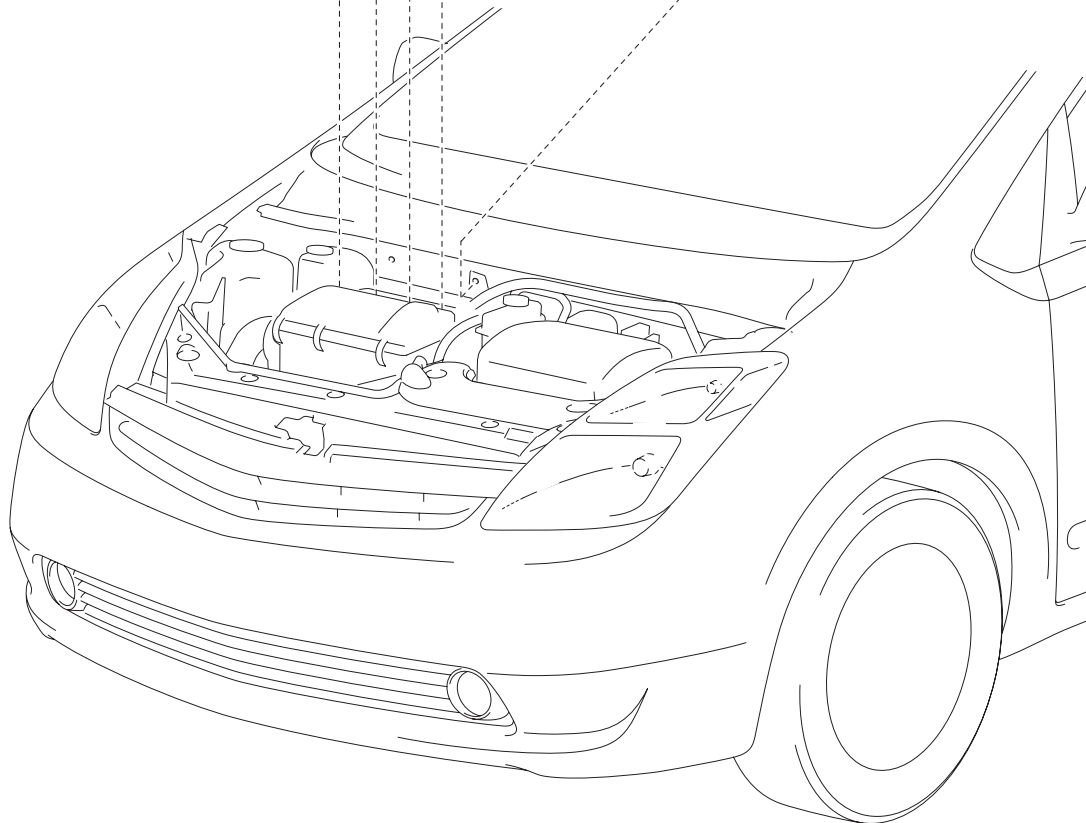
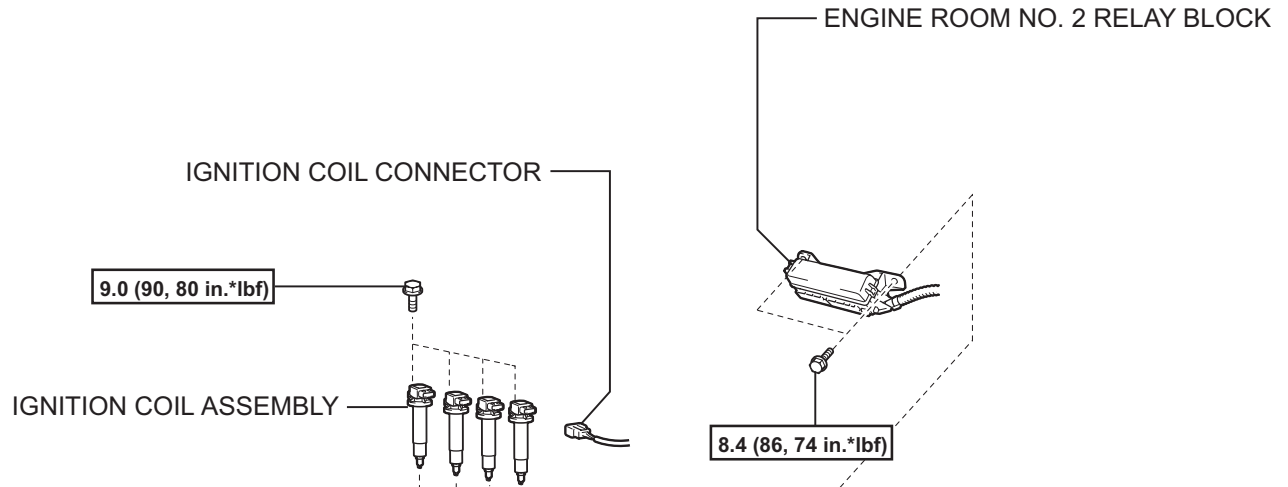

N*m (kgf*cm, ft.*lbf) : Specified torque

REMOVAL

1. REMOVE REAR NO. 2 FLOOR BOARD (See page CH-4)
2. REMOVE REAR DECK FLOOR BOX (See page CH-4)
3. REMOVE REAR NO. 3 FLOOR BOARD (See page CH-4)
4. DISCONNECT CABLE FROM NEGATIVE BATTERY TERMINAL
CAUTION:
Wait at least 90 seconds after disconnecting the cable from the negative (-) battery terminal to prevent airbag and seat belt pretensioner activation.
5. DISCONNECT ENGINE ROOM NO. 2 RELAY BLOCK
(a) Remove the 2 bolts and disconnect the relay block.
6. REMOVE IGNITION COIL ASSEMBLY
(a) Disconnect the 4 ignition coil connectors.

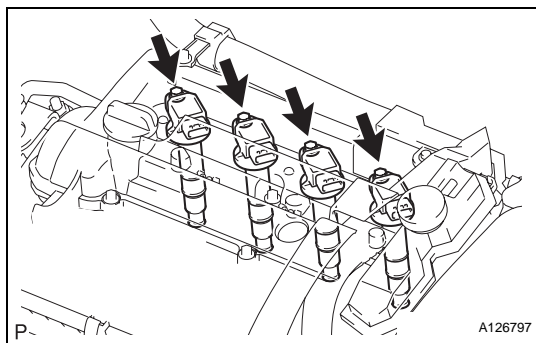
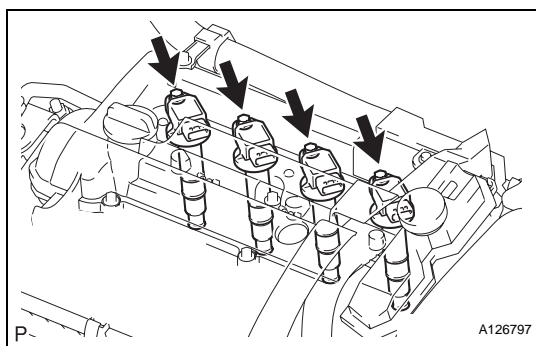
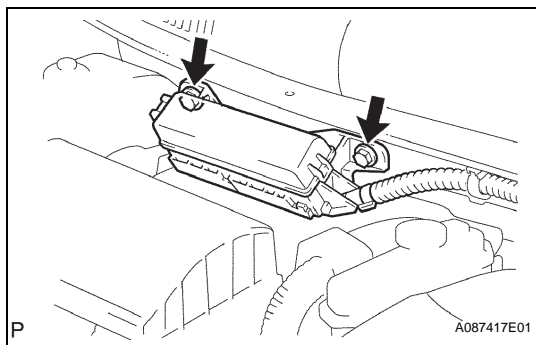

- (b) Remove the 4 bolts and pull out the 4 ignition coils.

INSTALLATION

1. INSTALL IGNITION COIL ASSEMBLY
(a) Install the 4 ignition coils with the 4 bolts.
Torque: 9.0 N*m (90 kgf*cm, 80 in.*lbf)
(b) Connect the 4 ignition coil connectors.

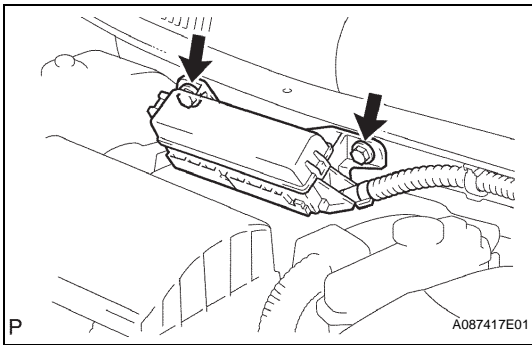

2. **INSTALL ENGINE ROOM NO. 2 RELAY BLOCK**
 - (a) Install the relay block with the 2 bolts.
Torque: 8.4 N*m (86 kgf*cm, 74 ft.*lbf)
3. **CONNECT CABLE TO NEGATIVE BATTERY TERMINAL**
4. **INSTALL REAR NO. 3 FLOOR BOARD** (See page [CH-8](#))
5. **INSTALL REAR DECK FLOOR BOX** (See page [CH-8](#))
6. **INSTALL REAR NO. 2 FLOOR BOARD** (See page [CH-8](#))
7. **PERFORM INITIALIZATION**
 - (a) Perform initialization (see page [IN-32](#)).
NOTICE:
Certain systems need to be initialized after disconnecting and reconnecting the cable from the negative (-) battery terminal.