

COMPONENTS

ILLUSTRATION

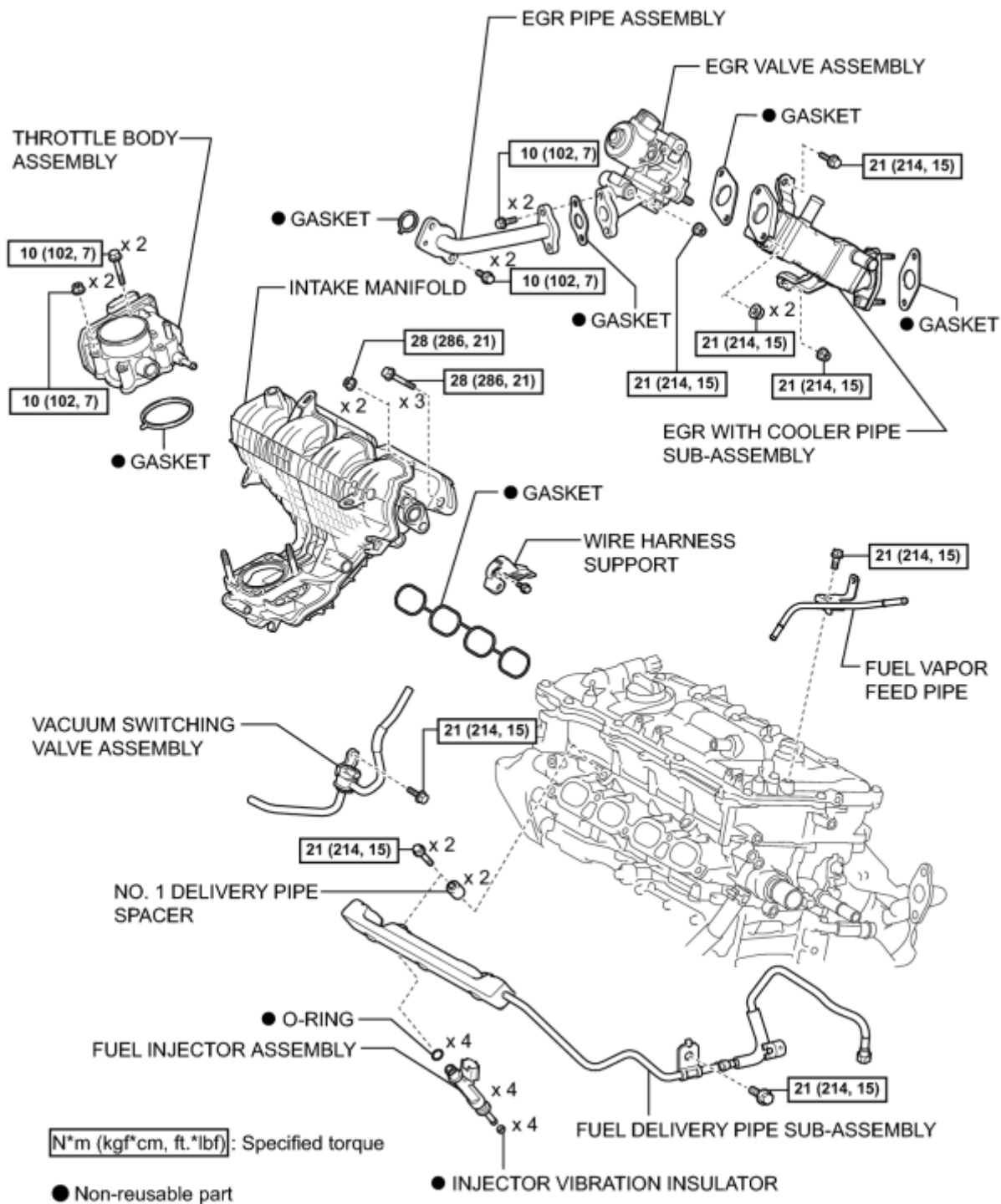

c

ILLUSTRATION

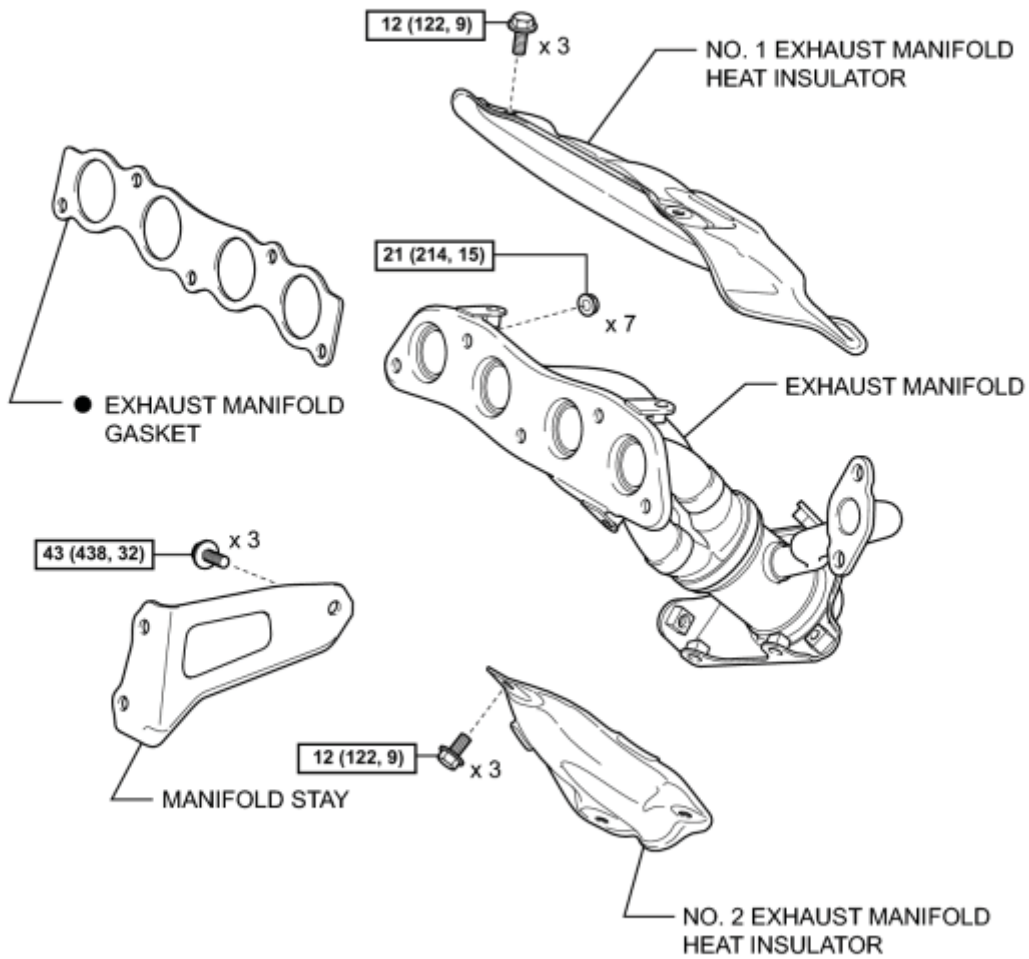

N*m (kgf*cm, ft.*lbf): Specified torque

● Non-reusable part

c

ILLUSTRATION

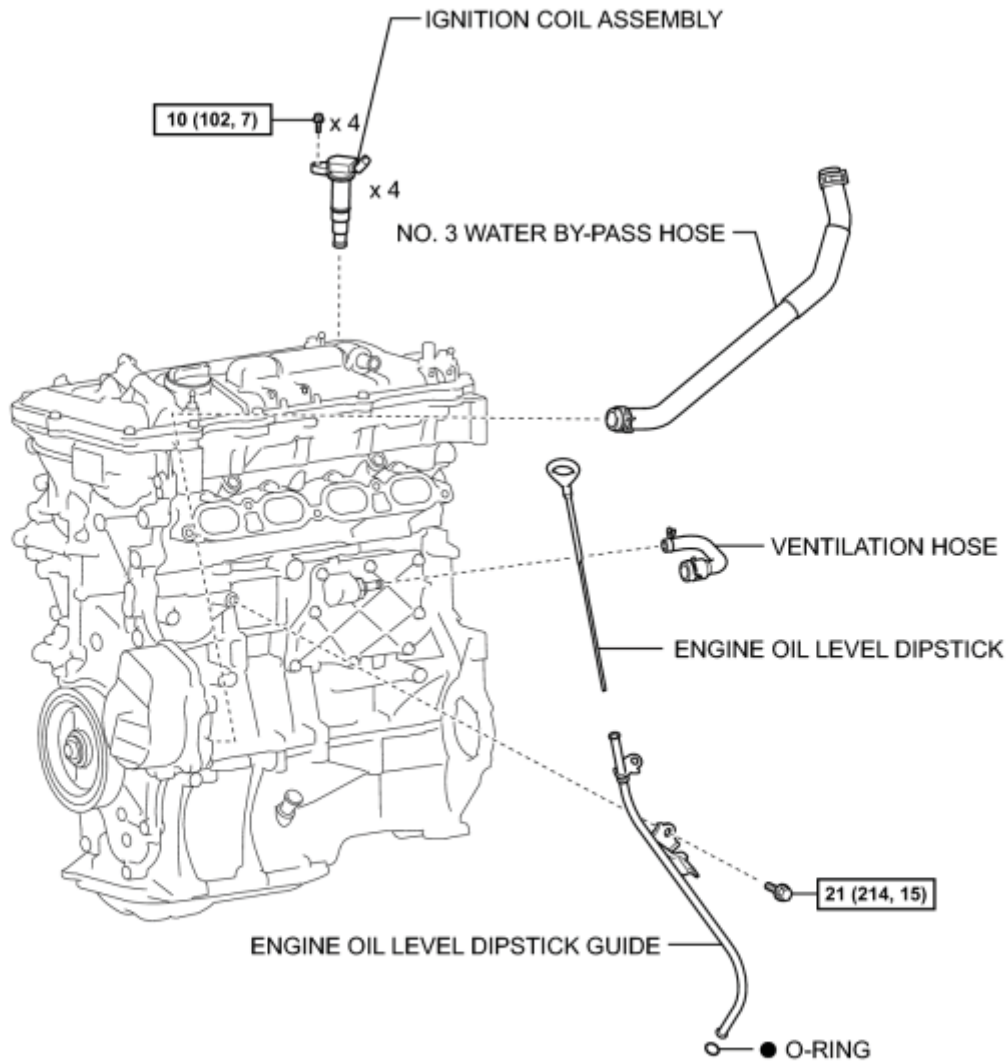

[N*m (kgf*cm, ft.*lbf)]: Specified torque

● Non-reusable part

c

ILLUSTRATION

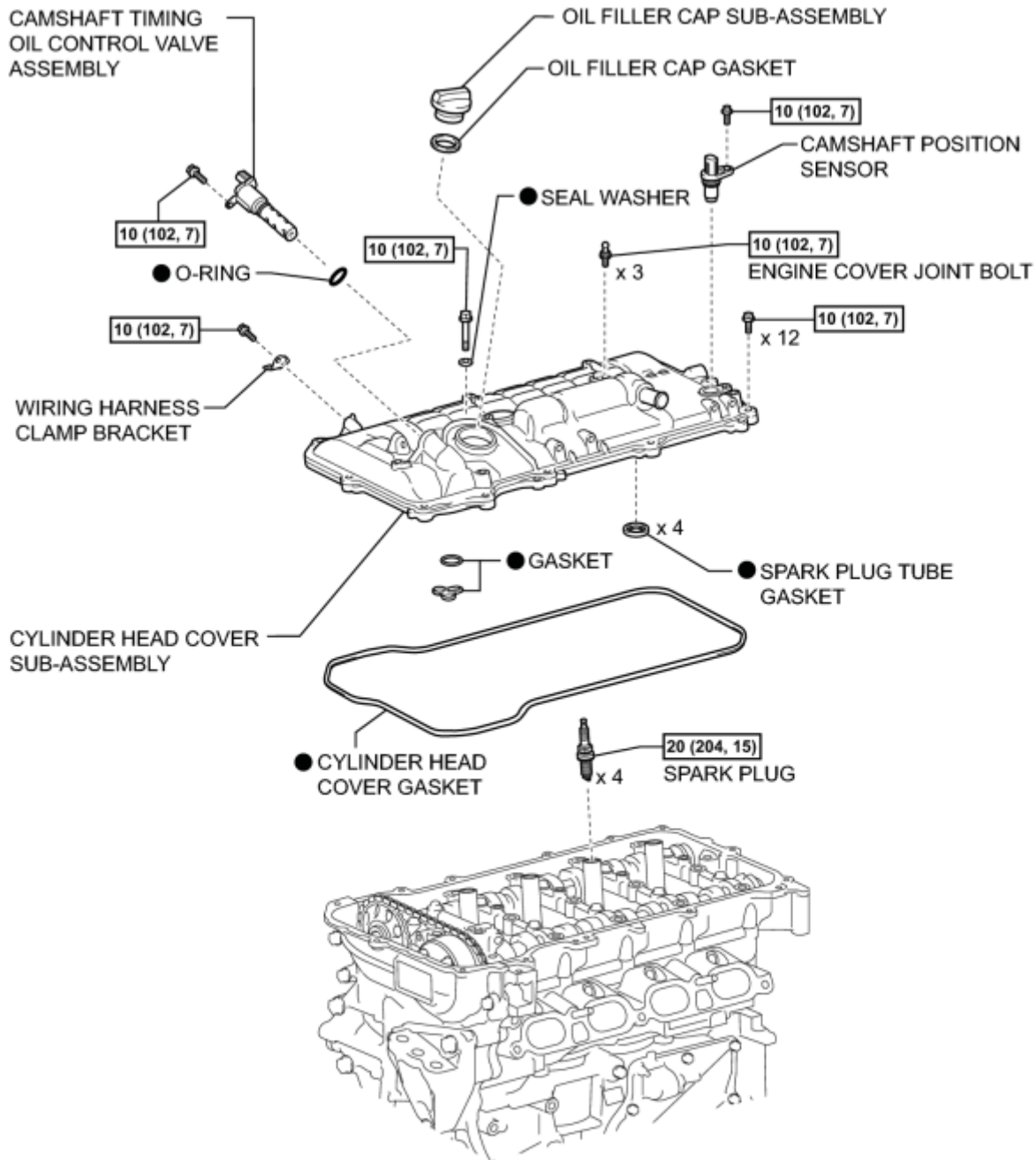

N*m (kgf*cm, ft.*lbf) : Specified torque

● Non-reusable part

c

ILLUSTRATION

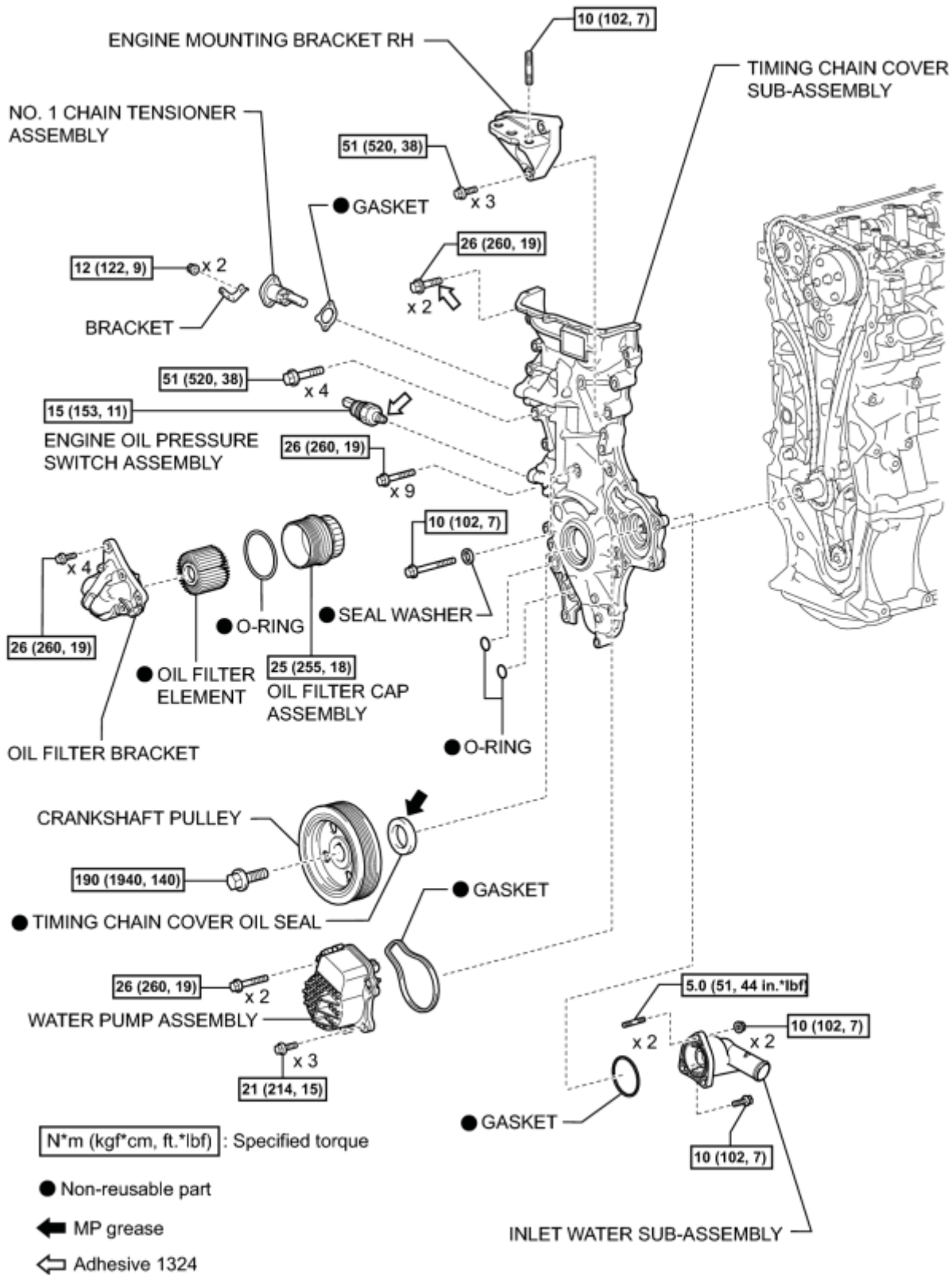

c

ILLUSTRATION

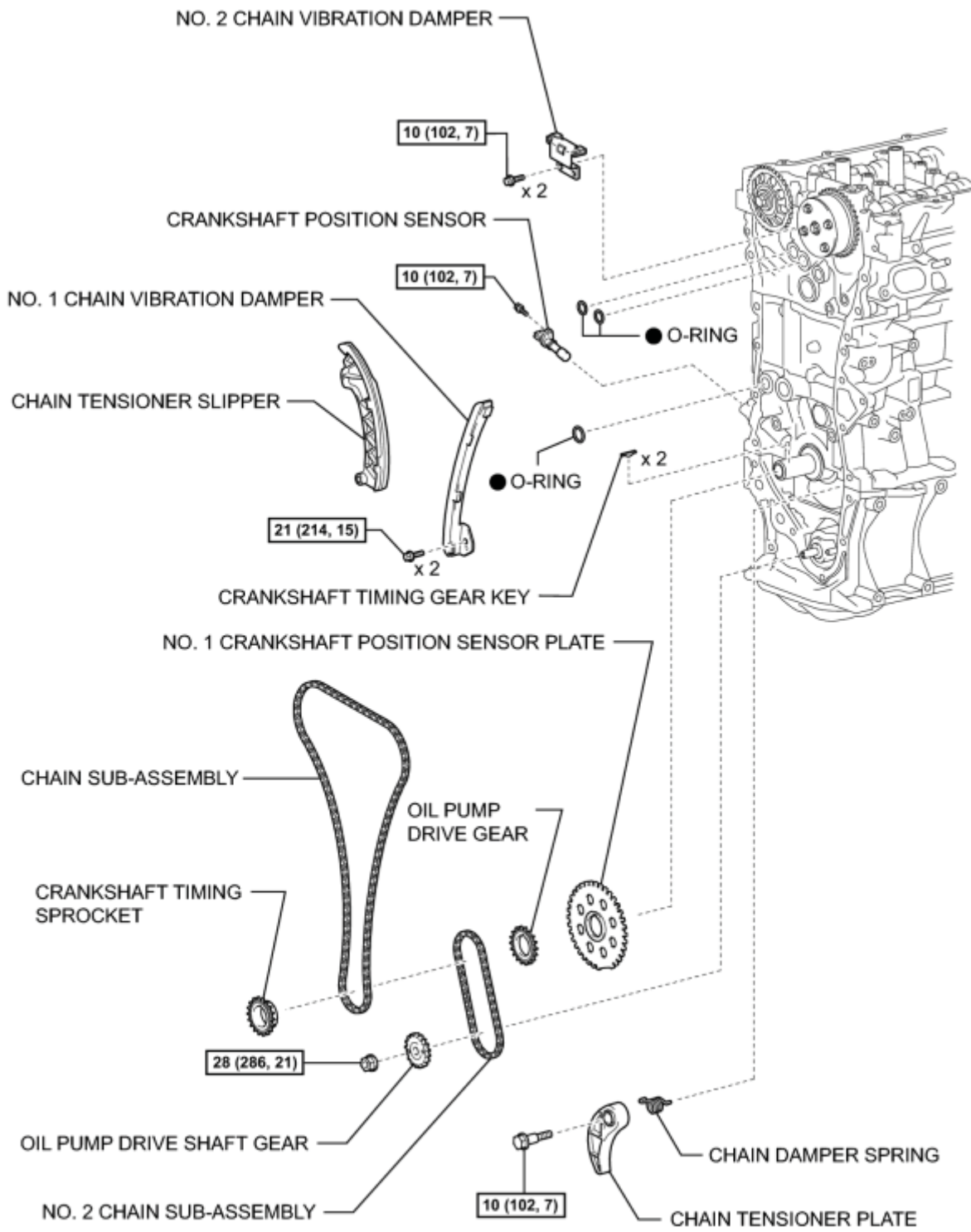

N*m (kgf*cm, ft.*lbf) : Specified torque

● Non-reusable part

c

ILLUSTRATION

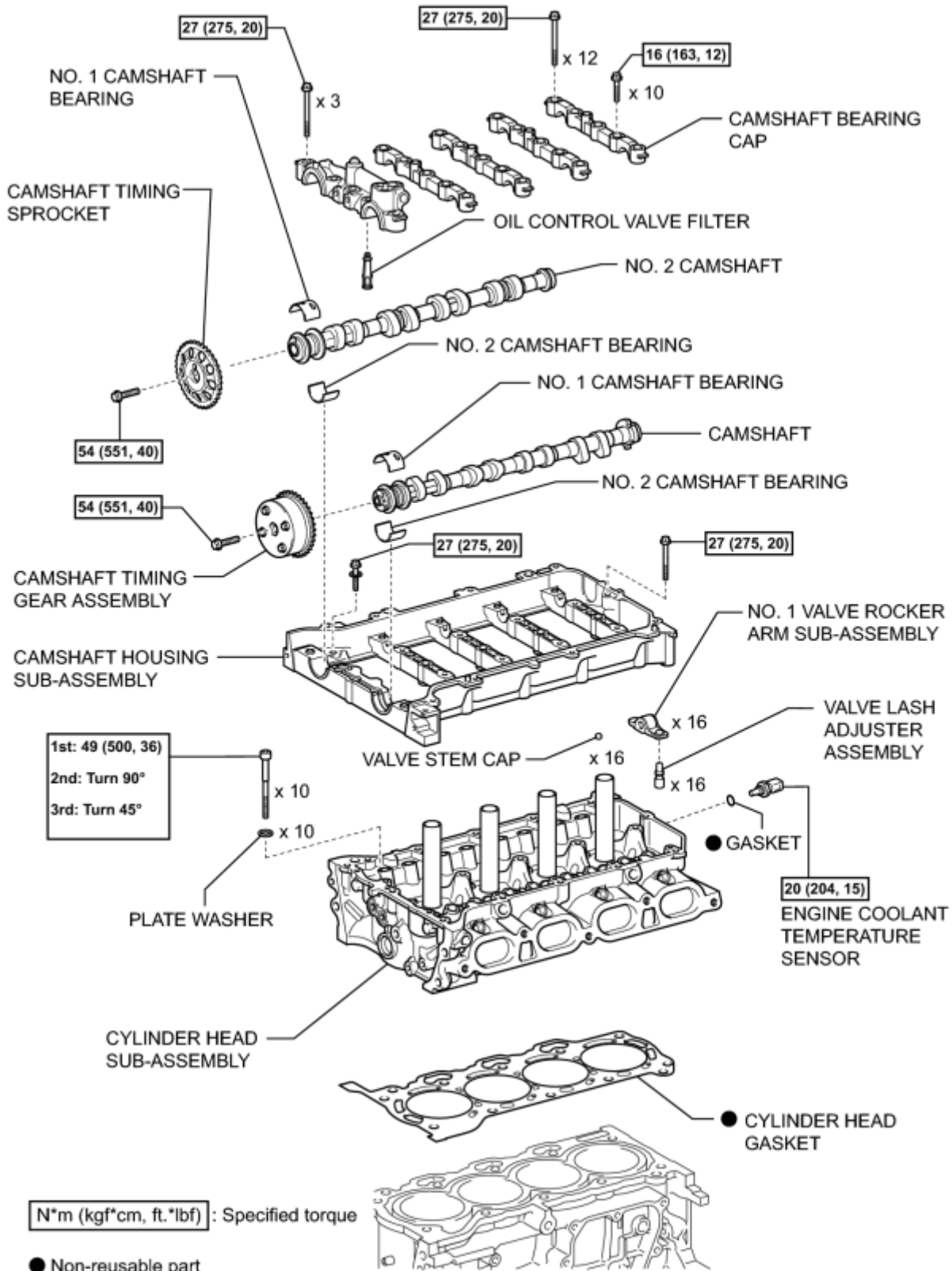

c

ILLUSTRATION

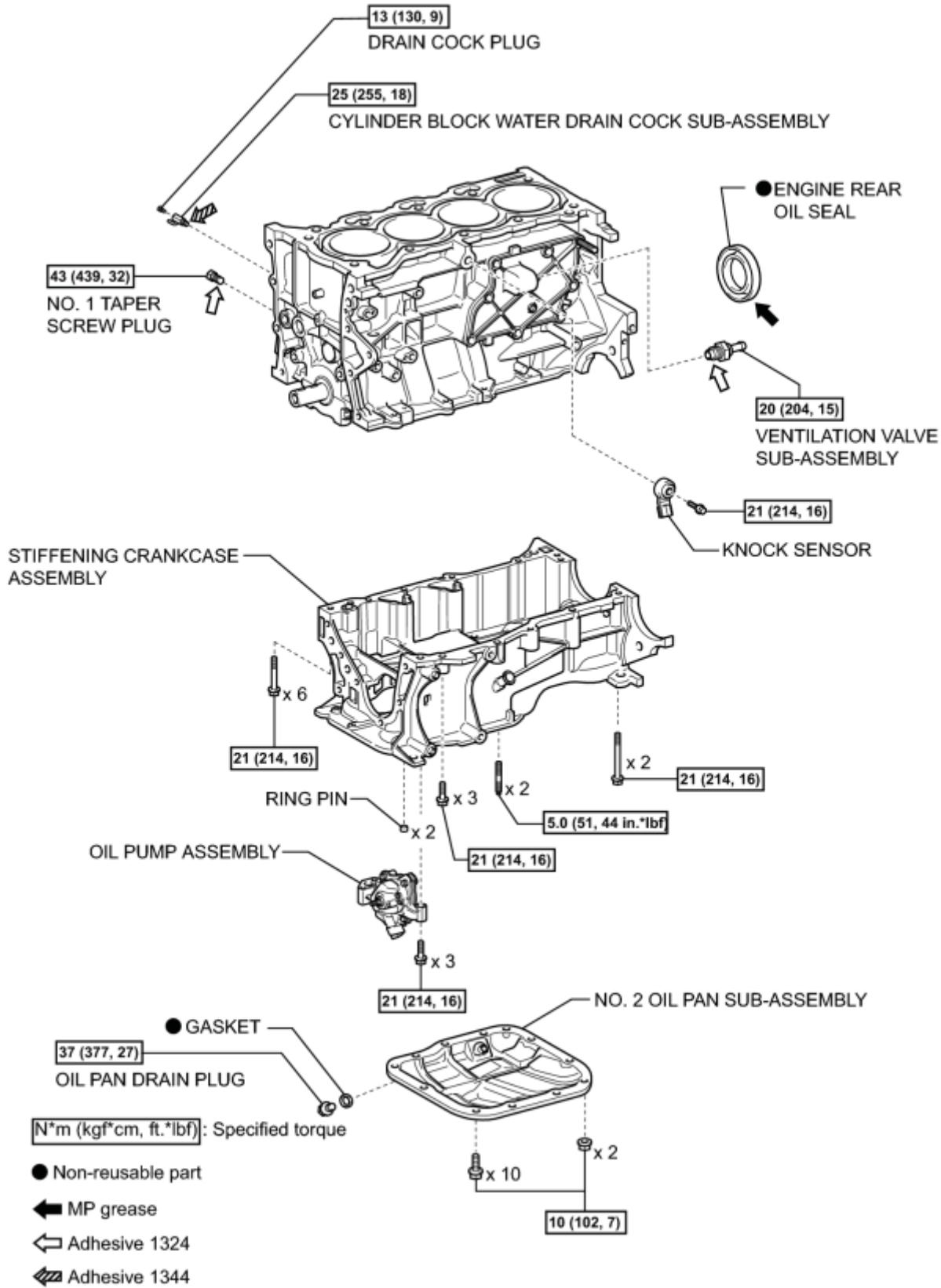

c

REMOVAL

1. INSTALL ENGINE ON ENGINE STAND

(a) Install the engine onto an engine stand with the bolts.

2. REMOVE ENGINE HANGERS

(a) Remove the 2 bolts and 2 engine hangers.

3. REMOVE THROTTLE BODY ASSEMBLY_ INFO

4. REMOVE ENGINE OIL LEVEL DIPSTICK GUIDE

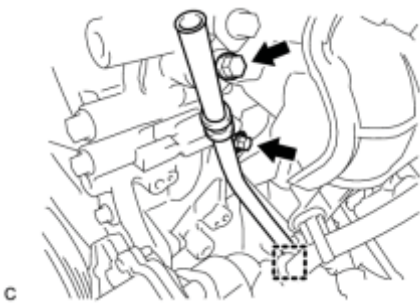

(a) Remove the engine oil level dipstick.

(b) Remove the 2 bolts, clamp and engine oil level dipstick guide.

(c) Remove the O-ring from the engine oil level dipstick guide.

5. REMOVE EGR PIPE ASSEMBLY_ INFO

6. REMOVE EGR VALVE ASSEMBLY_ INFO

7. REMOVE EGR WITH COOLER PIPE SUB-ASSEMBLY_ INFO

8. REMOVE INTAKE MANIFOLD_ INFO

9. REMOVE FUEL VAPOR FEED PIPE

(a) Remove the bolt and fuel vapor feed pipe.

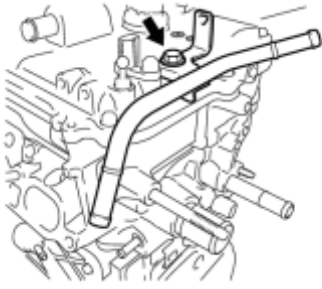

c

10. REMOVE FUEL DELIVERY PIPE SUB-ASSEMBLY_ INFO

11. REMOVE NO. 1 DELIVERY PIPE SPACER_ INFO

12. REMOVE FUEL INJECTOR ASSEMBLY_ INFO

13. REMOVE NO. 1 EXHAUST MANIFOLD HEAT INSULATOR_ INFO

14. REMOVE MANIFOLD STAY_ INFO

15. REMOVE EXHAUST MANIFOLD_ INFO

16. REMOVE VENTILATION HOSE

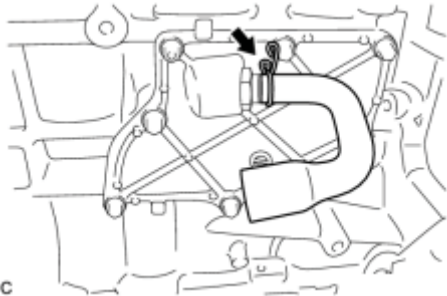

c

(a) Remove the ventilation hose from the ventilation valve.

17. REMOVE IGNITION COIL ASSEMBLY_ INFO

DISASSEMBLY

1. REMOVE OIL FILLER CAP SUB-ASSEMBLY

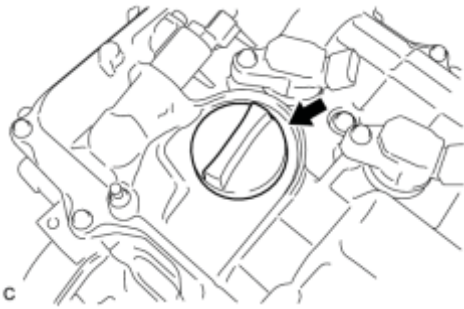

(a) Remove the oil filler cap.

2. REMOVE OIL FILLER CAP GASKET

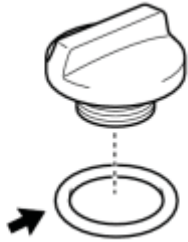

(a) Remove the oil filler cap gasket.

3. REMOVE ENGINE COVER JOINT BOLT

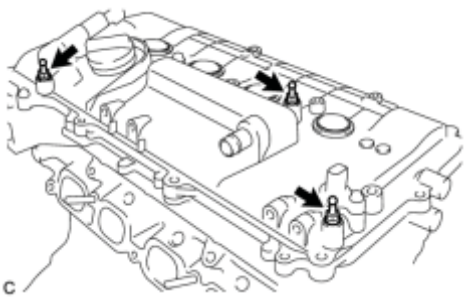

(a) Remove the 3 engine cover joint bolts.

4. REMOVE WIRING HARNESS CLAMP BRACKET

(a) Remove the bolt and wiring harness clamp bracket.

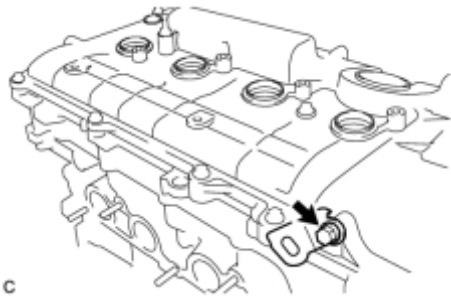

5. REMOVE SPARK PLUG INFO

6. REMOVE CAMSHAFT POSITION SENSOR

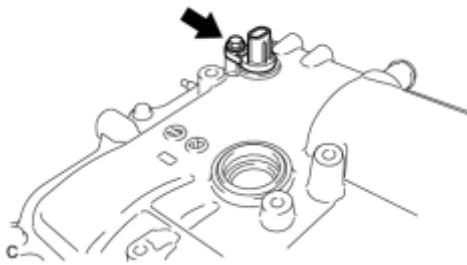

(a) Remove the bolt and camshaft position sensor.

7. REMOVE CAMSHAFT TIMING OIL CONTROL VALVE ASSEMBLY

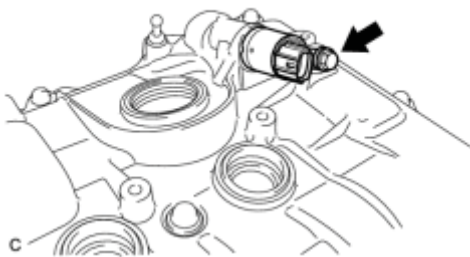

(a) Remove the bolt and camshaft timing oil control valve.

(b) Remove the O-ring from the camshaft timing oil control valve.

8. REMOVE CRANKSHAFT POSITION SENSOR

(a) Remove the bolt and crankshaft position sensor.

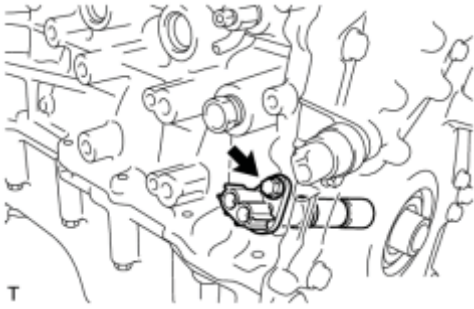

9. REMOVE ENGINE OIL PRESSURE SWITCH ASSEMBLY

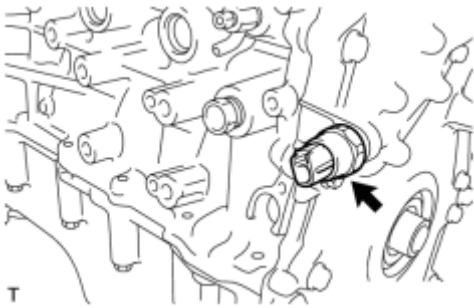

(a) Using a 24 mm deep socket wrench, remove the engine oil pressure switch assembly.

10. REMOVE KNOCK SENSOR

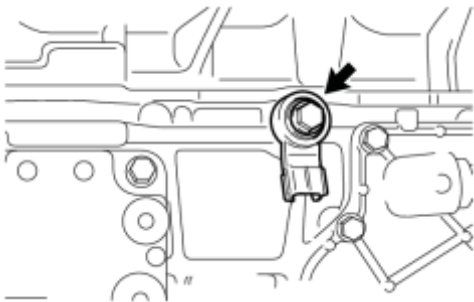

(a) Remove the bolt and knock sensor.

11. REMOVE ENGINE COOLANT TEMPERATURE SENSOR

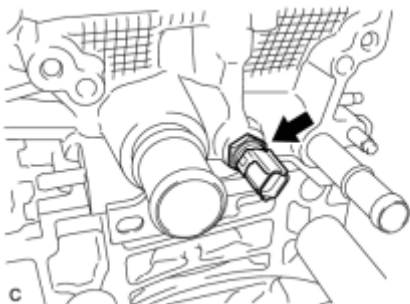

(a) Remove the engine coolant temperature sensor and gasket.

12. REMOVE CYLINDER HEAD COVER SUB-ASSEMBLY

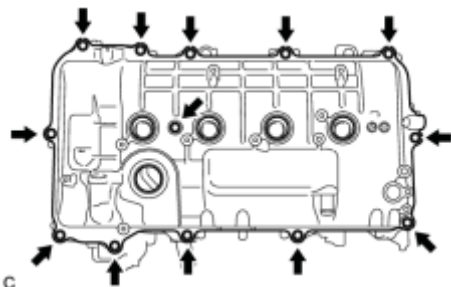

(a) Remove the 13 bolts, seal washer and cylinder head cover.

NOTICE:

As gasket may stick to the cylinder head cover, be careful not to drop any of the gaskets into the engine when removing the cylinder head cover.

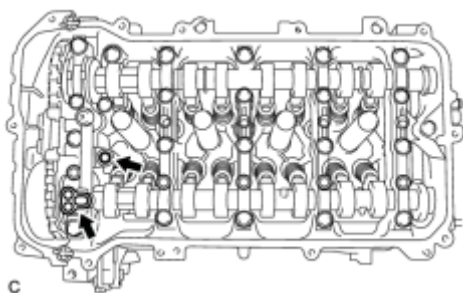

(b) Remove the 2 gaskets from the camshaft bearing cap.

13. REMOVE CYLINDER HEAD COVER GASKET

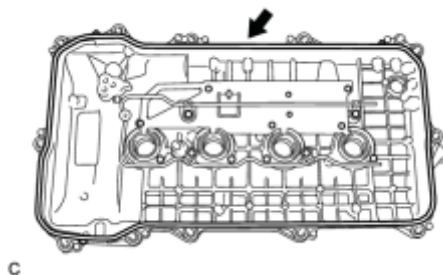

(a) Remove the cylinder head cover gasket.

14. REMOVE SPARK PLUG TUBE GASKET

(a) Pry up the 4 claws of the ventilation baffle plate.

NOTICE:

Do not deform the claws of the baffle plate more than necessary.

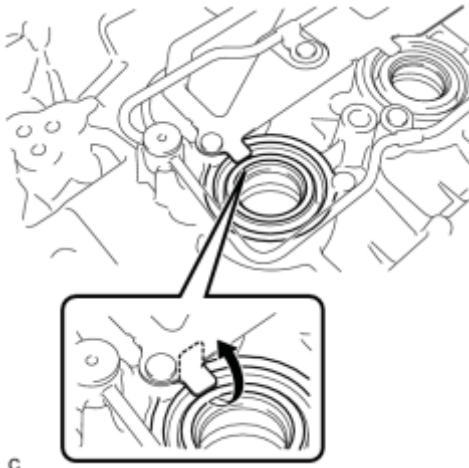

(b) Remove the 4 gaskets from the cylinder head cover.

HINT:

Prevent the plug tube gaskets from being deformed as much as possible. The removed gaskets will be used when installing new gaskets.

NOTICE:

Be careful not to damage the cylinder head cover.

15. REMOVE OIL FILTER CAP ASSEMBLY INFO

16. REMOVE INLET WATER SUB-ASSEMBLY

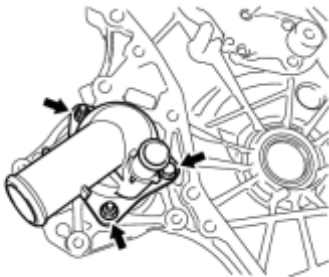

(a) Remove the bolt, 2 nuts, inlet water sub-assembly and gasket.

c

17. REMOVE INLET WATER SUB-ASSEMBLY STUD BOLT

NOTICE:

If a stud bolt is deformed or its threads are damaged, replace it.

18. SET NO. 1 CYLINDER TO TDC/COMPRESSION INFO

19. REMOVE CRANKSHAFT PULLEY INFO

20. REMOVE NO. 1 CHAIN TENSIONER ASSEMBLY_ INFO

21. REMOVE TIMING CHAIN COVER SUB-ASSEMBLY_ INFO

22. REMOVE TIMING CHAIN COVER OIL SEAL_ INFO

23. REMOVE CHAIN TENSIONER SLIPPER_ INFO

24. REMOVE NO. 1 CHAIN VIBRATION DAMPER_ INFO

25. REMOVE NO. 2 CHAIN VIBRATION DAMPER_ INFO

26. REMOVE CHAIN SUB-ASSEMBLY_ INFO

27. REMOVE CRANKSHAFT TIMING SPROCKET_ INFO

28. REMOVE NO. 2 CHAIN SUB-ASSEMBLY_ INFO

29. REMOVE NO. 1 CRANKSHAFT POSITION SENSOR PLATE

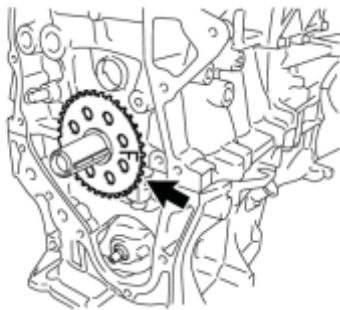

(a) Remove the crankshaft position sensor plate.

T

30. REMOVE CRANKSHAFT TIMING GEAR KEY

(a) Using a screwdriver, remove the 2 crankshaft timing gear keys.

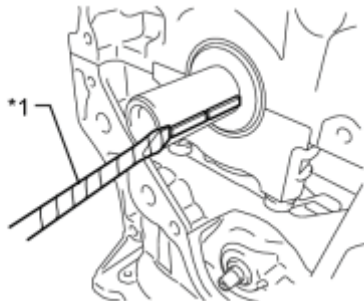

Text in Illustration

*1	Protective Tape
----	-----------------

HINT:

Tape the screwdriver tip before use.

T

31. INSPECT CAMSHAFT TIMING GEAR ASSEMBLY_ INFO

32. REMOVE CAMSHAFT TIMING GEAR ASSEMBLY_ INFO

33. REMOVE CAMSHAFT TIMING SPROCKET_ INFO

34. REMOVE CAMSHAFT BEARING CAP_ INFO

35. REMOVE CAMSHAFT_ INFO

36. REMOVE NO. 2 CAMSHAFT_ INFO

37. REMOVE CAMSHAFT HOUSING STRAIGHT PIN

NOTICE:

It is not necessary to remove a straight pin unless it is being replaced.

38. REMOVE NO. 1 VALVE ROCKER ARM SUB-ASSEMBLY

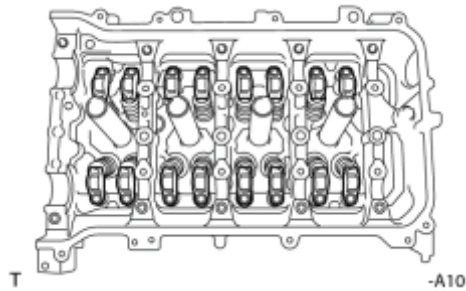

(a) Remove the 16 valve rocker arms.

HINT:

Arrange the removed parts in the correct order.

39. REMOVE VALVE LASH ADJUSTER ASSEMBLY

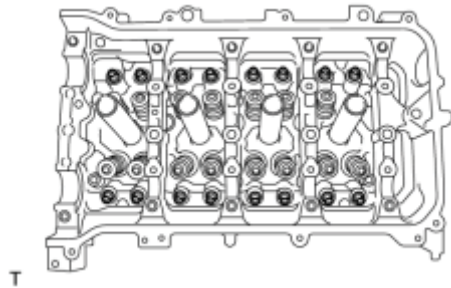

(a) Remove the 16 valve lash adjusters from the cylinder head.

HINT:

Arrange the removed parts in the correct order.

40. REMOVE VALVE STEM CAP

(a) Remove the 16 valve stem caps.

HINT:

Arrange the removed parts in the correct order.

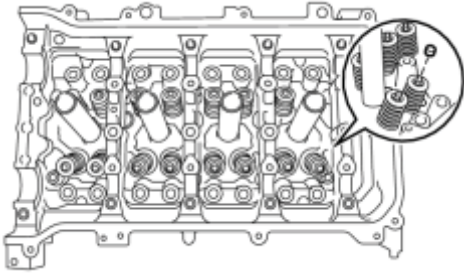

41. REMOVE OIL CONTROL VALVE FILTER

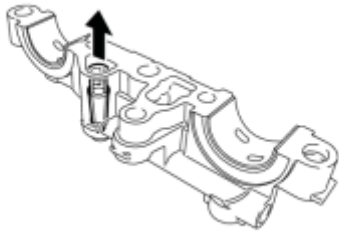

(a) Remove the oil control valve filter from the No. 1 camshaft bearing cap.

c

42. REMOVE NO. 1 CAMSHAFT BEARING

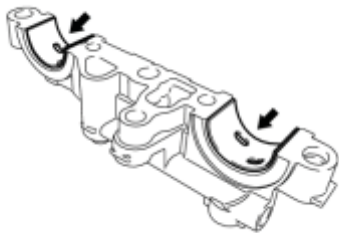

(a) Remove the 2 camshaft bearings

c

43. REMOVE NO. 2 CAMSHAFT BEARING



(a) Remove the 2 camshaft bearings.

T

44. REMOVE CAMSHAFT HOUSING SUB-ASSEMBLY_ INFO

45. REMOVE CYLINDER HEAD SUB-ASSEMBLY_ INFO

46. REMOVE CYLINDER HEAD GASKET_ INFO

47. REMOVE CYLINDER BLOCK WATER DRAIN COCK SUB-ASSEMBLY

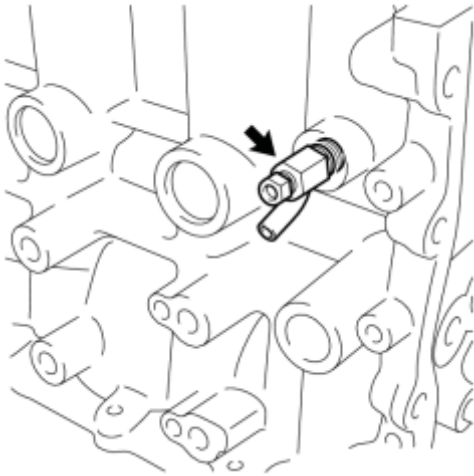

(a) Remove the drain cock plug from the drain cock.

(b) Remove the drain cock from the cylinder block.

48. REMOVE VENTILATION VALVE SUB-ASSEMBLY

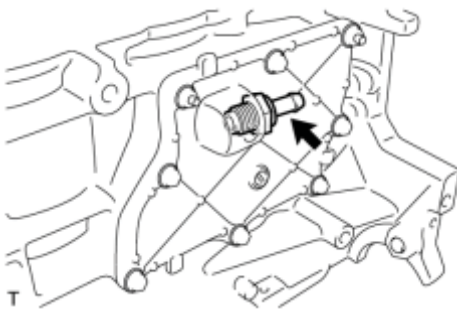

(a) Remove the ventilation valve sub-assembly.

49. REMOVE OIL PAN DRAIN PLUG

(a) Remove the drain plug and gasket.

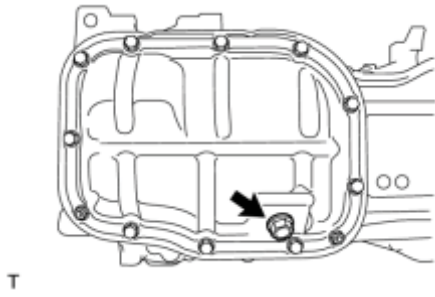

T

50. REMOVE NO. 2 OIL PAN SUB-ASSEMBLY_ INFO

51. REMOVE OIL PUMP ASSEMBLY_ INFO

52. REMOVE STIFFENING CRANKCASE ASSEMBLY

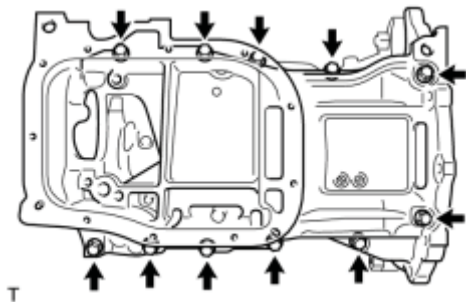

T

(a) Uniformly loosen and remove the 11 bolts.

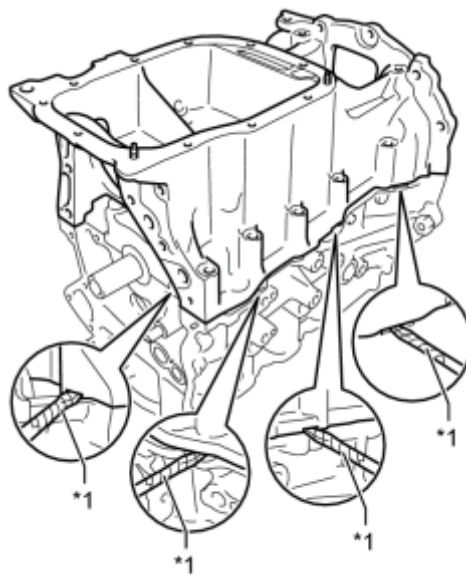

T

(b) Using a screwdriver, remove the stiffening crankcase by prying between the stiffening crankcase and cylinder block.

Text in Illustration

*1	Protective Tape
----	-----------------

HINT:

Tape the screwdriver tip before use.

NOTICE:

Be careful not to damage the contact surfaces of the crankcase and cylinder block.

53. REMOVE ENGINE REAR OIL SEAL

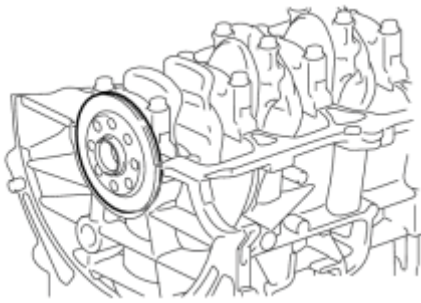

(a) Remove the engine rear oil seal from the cylinder block.

54. REMOVE NO. 1 TAPER SCREW PLUG

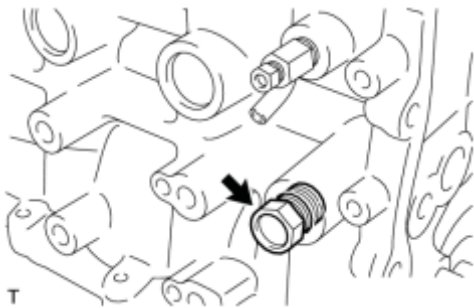

(a) Remove the screw plug.

55. REMOVE STIFFENING CRANKCASE STUD BOLT

NOTICE:

If a stud bolt is deformed or its threads are damaged, replace it.

56. REMOVE STIFFENING CRANKCASE RING PIN

NOTICE:

It is not necessary to remove a ring pin unless it is being replaced.

INSPECTION

1. INSPECT NO. 1 VALVE ROCKER ARM SUB-ASSEMBLY



(a) Turn the roller by hand to check that it turns smoothly.

If the roller does not turn smoothly, replace the No. 1 valve rocker arm sub-assembly.

T

2. INSPECT VALVE LASH ADJUSTER ASSEMBLY

NOTICE:

- Keep the valve lash adjuster free from dirt and foreign matter.
- Only use clean engine oil.

(a) Place the lash adjuster into a container full of new engine oil.

(b) Insert the tip of SST into the lash adjuster plunger and use the tip to press down on the check ball inside the plunger.

Text in Illustration

*1	Plunger
*2	Check Ball
*3	Low Pressure Chamber
*4	High Pressure Chamber
*a	CORRECT
*b	INCORRECT
*c	Taper Part

SST: 09276-75010

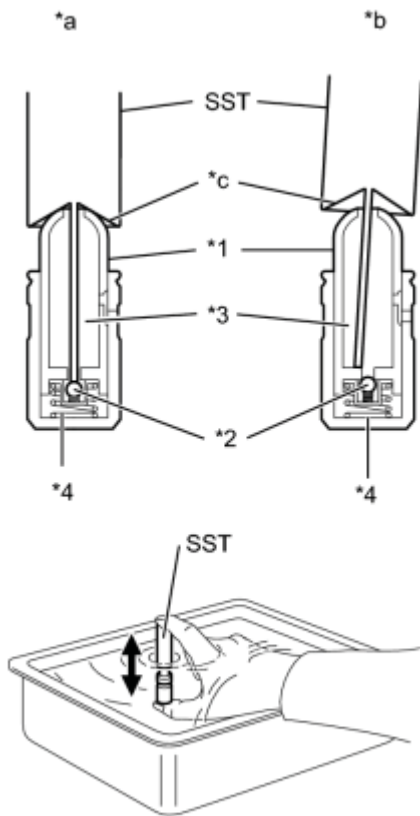

T

(c) Squeeze SST and the valve lash adjuster together to move the plunger up and down 5 to 6 times.

(d) Check the movement of the plunger and bleed the air.

OK:

Plunger moves up and down.

NOTICE:

When bleeding high-pressure air from the compression chamber, make sure that the tip of SST is actually pressing the check ball as shown in the illustration. If the check ball is not pressed, air bleeding is not possible.

(e) After bleeding the air, remove SST. Then try to quickly and firmly press the plunger with your fingers.

OK:

Plunger can be pressed 3 times.

If the plunger can still be compressed after pressing it 3 times, replace the valve lash adjuster with a new one.

3. INSPECT CHAIN SUB-ASSEMBLY

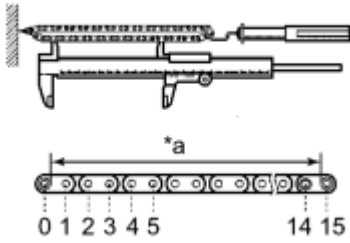

(a) Pull the chain with a force of 147 N (15 kgf, 33.0 lbf) as shown in the illustration.

Text in Illustration

*a	Measurement Length
----	--------------------

(b) Using a vernier caliper, measure the length of 15 links.

Maximum chain elongation:

115.2 mm (4.54 in.)

NOTICE:

Perform the measurement at 3 random places. Use the average of the measurements.

If the average elongation is more than the maximum, replace the chain sub-assembly.

4. INSPECT NO. 2 CHAIN SUB-ASSEMBLY

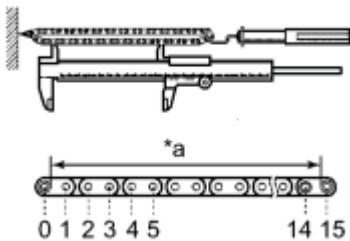

(a) Pull the chain with a force of 147 N (15 kgf, 33.0 lbf) as shown in the illustration.

Text in Illustration

*a	Measurement Length
----	--------------------

(b) Using a vernier caliper, measure the length of 15 links.

Maximum chain elongation:

102.1 mm (4.02 in.)

NOTICE:

Perform the measurement at 3 random places. Use the average of the measurements.

If the average elongation is more than the maximum, replace the No. 2 chain sub-assembly.

5. INSPECT OIL PUMP DRIVE GEAR

(a) Place the chain around the oil pump drive gear.

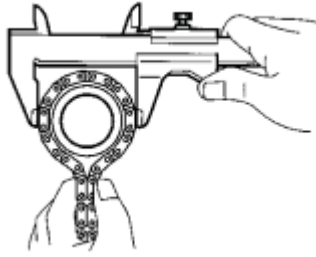

(b) Using a vernier caliper, measure the diameter of the oil pump drive gear and chain.

Minimum gear diameter (with chain):

48.2 mm (1.90 in.)

NOTICE:

The vernier caliper must be in contact with the chain rollers when measuring.

If the diameter is less than the minimum, replace the chain and oil pump drive gear.

6. INSPECT OIL PUMP DRIVE SHAFT GEAR

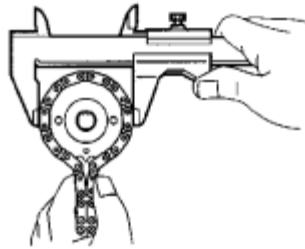

(a) Place the chain around the oil pump drive shaft gear.

(b) Using a vernier caliper, measure the diameter of the oil pump drive shaft gear and chain.

Minimum gear diameter (with chain):

48.2 mm (1.90 in.)

NOTICE:

The vernier caliper must be in contact with the chain rollers when measuring.

If the diameter is less than the minimum, replace the chain and oil pump drive shaft gear.

7. INSPECT CAMSHAFT TIMING GEAR ASSEMBLY

(a) Place the chain around the camshaft timing gear assembly.

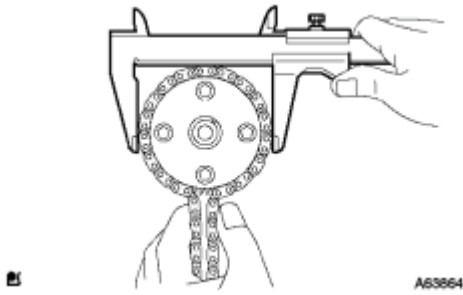

(b) Using a vernier caliper, measure the diameter of the camshaft timing gear assembly and chain.

Minimum gear diameter (with chain):

96.8 mm (3.81 in.)

NOTICE:

The vernier caliper must be in contact with the chain rollers when measuring.

If the diameter is less than the minimum, replace the chain and camshaft timing gear assembly.

8. INSPECT CAMSHAFT TIMING SPROCKET

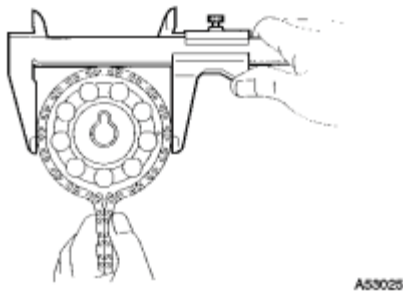

(a) Place the chain around the camshaft timing sprocket.

(b) Using a vernier caliper, measure the diameter of the camshaft timing sprocket and chain.

Minimum gear diameter (with chain):

96.8 mm (3.81 in.)

NOTICE:

The vernier caliper must be in contact with the chain rollers when measuring.

If the diameter is less than the minimum, replace the chain and camshaft timing sprocket.

9. INSPECT CRANKSHAFT TIMING GEAR

(a) Place the chain around the crankshaft timing gear.

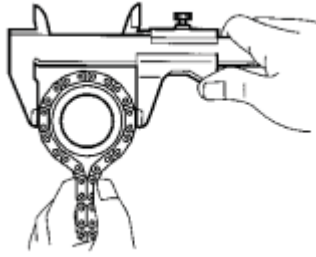

(b) Using a vernier caliper, measure the diameter of the crankshaft timing gear and chain.

Minimum gear diameter (with chain):

51.1 mm (2.01 in.)

NOTICE:

The vernier caliper must be in contact with the chain rollers when measuring.

If the diameter is less than the minimum, replace the chain and crankshaft timing gear.

10. INSPECT CHAIN TENSIONER SLIPPER

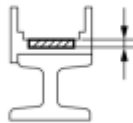
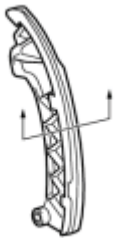

(a) Using a vernier caliper, measure the chain tensioner slipper wear.

Maximum wear:

1.0 mm (0.0394 in.)

If the wear is more than the maximum, replace the chain tensioner slipper.

T

11. INSPECT NO. 1 CHAIN VIBRATION DAMPER

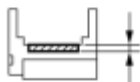
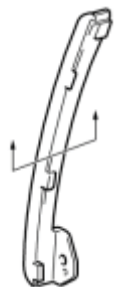

(a) Using a vernier caliper, measure the No. 1 chain vibration damper wear.

Maximum wear:

1.0 mm (0.0394 in.)

If the wear is more than the maximum, replace the No. 1 chain vibration damper.

T

12. INSPECT NO. 2 CHAIN VIBRATION DAMPER

(a) Using a vernier caliper, measure the No. 2 chain vibration damper

wear.

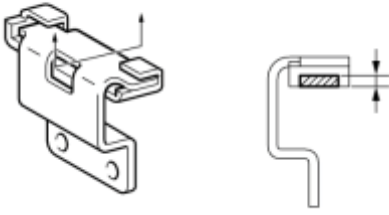

Maximum wear:

1.0 mm (0.0394 in.)

If the wear is more than the maximum, replace the No. 2 chain vibration damper.

T

13. INSPECT CHAIN TENSIONER PLATE

(a) Using a vernier caliper, measure the chain tensioner plate wear.

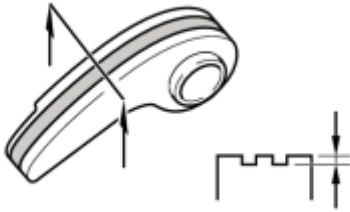

Maximum wear:

1.0 mm (0.0394 in.)

If the wear is more than the maximum, replace the chain tensioner plate.

T

14. INSPECT NO. 1 CHAIN TENSIONER

(a) Check that the plunger moves smoothly when the cam is raised with your finger.

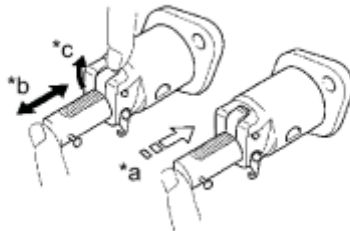

Text in Illustration

*a	Lock
*b	Move
*c	Raise

(b) Release the cam, then check that the plunger is locked in place by the cam and does not move when pushing with your finger.

If necessary, replace the No. 1 chain tensioner.

15. INSPECT CAMSHAFT

(a) Inspect the camshaft for runout.

(1) Place the camshaft on V-blocks.

(2) Using a dial indicator, measure the circle runout at the center journal.

Maximum circle runout:

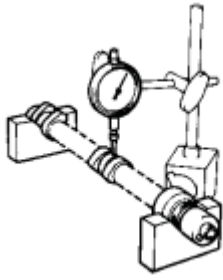

0.04 mm (0.00157 in.)

If the circle runout is more than the maximum, replace the camshaft.

(b) Inspect the cam lobes.

(1) Using a micrometer, measure the cam lobe height.

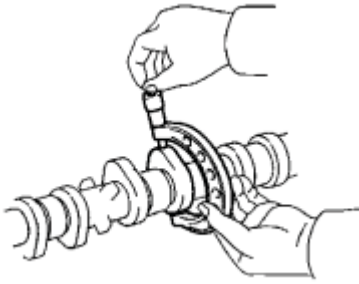

Standard cam lobe height:

41.779 to 41.879 mm (1.6448 to 1.6488 in.)

Minimum cam lobe height:

41.629 mm (1.6389 in.)

If the cam lobe height is less than the minimum, replace the camshaft.

(c) Inspect the camshaft journals.

(1) Using a micrometer, measure the journal diameter.

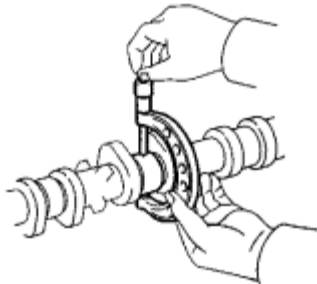

Standard Journal Diameter:

Journal Position	Specified Condition
No. 1	34.449 to 34.465 mm (1.3563 to 1.3569 in.)
Other	22.949 to 22.965 mm (0.90350 to 0.90413 in.)

If the journal diameter is not as specified, check the oil clearance INFO.

16. INSPECT NO. 2 CAMSHAFT

(a) Inspect the No. 2 camshaft for runout.

(1) Place the No. 2 camshaft on V-blocks.

(2) Using a dial indicator, measure the circle runout at the center journal.

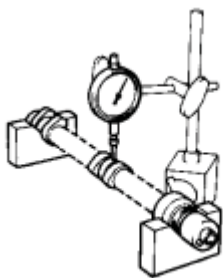

Maximum circle runout:

0.04 mm (0.00157 in.)

If the circle runout is more than the maximum, replace the No. 2 camshaft.

(b) Inspect the cam lobes.

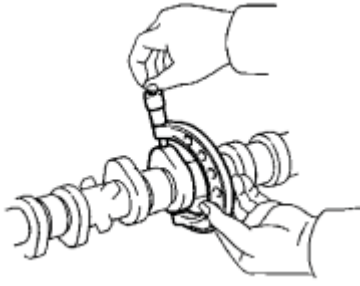

(1) Using a micrometer, measure the cam lobe height.

Standard cam lobe height:

43.346 to 43.446 mm (1.7065 to 1.7105 in.)

Minimum cam lobe height:

43.196 mm (1.7006 in.)

If the cam lobe height is less than the minimum, replace the No. 2 camshaft.

(c) Inspect the camshaft journals.

(1) Using a micrometer, measure the journal diameter.

Standard Journal Diameter:

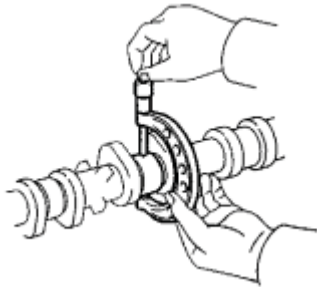

Journal Position	Specified Condition
No. 1	34.449 to 34.465 mm (1.3563 to 1.3569 in.)
Other	22.949 to 22.965 mm (0.90350 to 0.90413 in.)

If the journal diameter is not as specified, check the oil clearance INFO.

17. INSPECT CYLINDER HEAD SET BOLT

(a) Using a vernier caliper, measure the length of the cylinder head set bolt from the seat to the end.

Text in Illustration

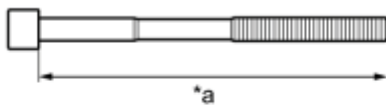

*a	Measurement Length
*b	Measurement Area
*c	Distance

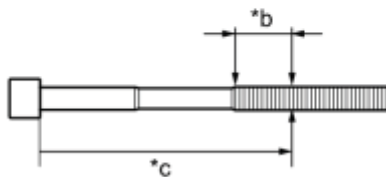

Standard length:

146.8 to 148.2 mm (5.78 to 5.83 in.)

Maximum length:

149.2 mm (5.87 in.)

If the length is more than the maximum, replace the cylinder head set bolt.

(b) Using a vernier caliper, measure the diameter of the elongated thread at the measurement point.

Measurement point:

115 mm (4.53 in.)

Standard diameter:

9.77 to 9.96 mm (0.385 to 0.392 in.)

Minimum diameter:

9.4 mm (0.370 in.)

If the diameter is less than the minimum, replace the cylinder head bolt.

HINT:

If a visual check reveals no excessively thin areas, check the center of the bolt (refer to illustration) and find the area that has the smallest diameter.

18. INSPECT EXHAUST MANIFOLD

(a) Using a precision straightedge and feeler gauge, measure the warpage on the surface that contacts the cylinder head.

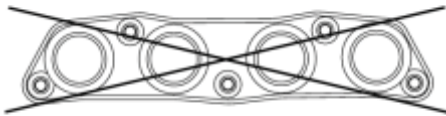

Maximum warpage:

0.7 mm (0.0276 in.)

If the warpage is more than the maximum, replace the exhaust manifold.

REASSEMBLY

1. INSTALL STIFFENING CRANKCASE RING PIN

NOTICE:

It is not necessary to remove a ring pin unless it is being replaced.

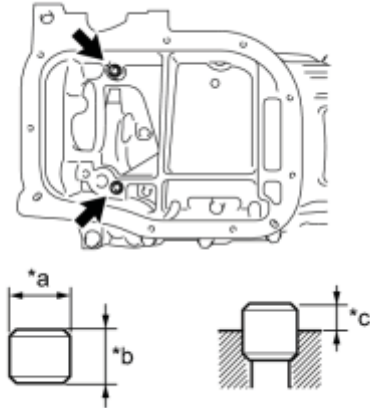

Text in Illustration

*a	Width
*b	Height
*c	Protrusion Height

(a) Using a plastic-faced hammer, tap in 2 new ring pins until they stop.

Standard Ring Pin:

Item	Protrusion Height	Height	Width
Ring pin	3.0 mm (0.118 in.)	11 mm (0.433 in.)	8 mm (0.315 in.)

2. INSTALL STIFFENING CRANKCASE STUD BOLT

NOTICE:

If a stud bolt is deformed or the threads are damaged, replace it.

(a) Using an E6 "TORX" socket wrench, install the stud bolts as shown in the illustration.

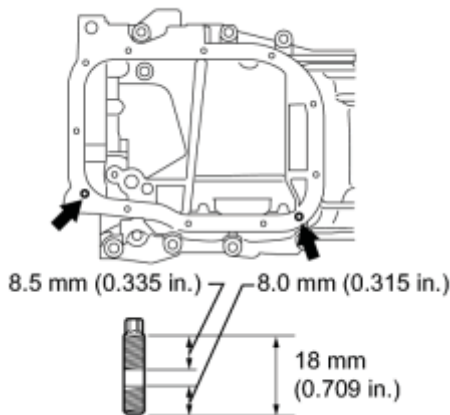

Torque: **5.0 N·m (51 kgf·cm, 44in·lbf)**

T

3. INSTALL STIFFENING CRANKCASE ASSEMBLY

(a) Apply seal packing in a continuous line as shown in the illustration.

Seal packing:

Toyota Genuine Seal Packing Black, Three bond 1207B or equivalent

Standard Seal Diameter:

Area	Specified Condition
------	---------------------

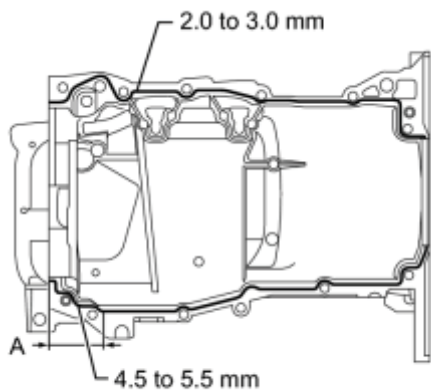

Continuous Line	2.0 to 3.0 mm (0.0787 to 0.118 in.)
A	4.5 to 5.5 mm (0.177 to 0.217 in.)

Application Length A:

56 mm (2.20 in.)

- Remove any oil from the contact surfaces.
- Install the crankcase within 3 minutes and tighten the bolts within 15 minutes of applying seal packing.
- Do not start the engine for at least 2 hours after installing the stiffening crankcase assembly.

T

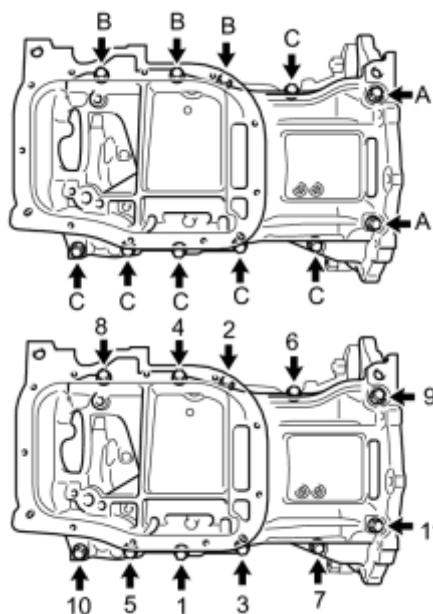

(b) Install the stiffening crankcase with the 11 bolts in the sequence shown in the illustration.

Torque: **21 N·m (214 kgf·cm, 15ft·lbf)**

Bolt Length:

Item	Specified Condition
Bolt A	138 mm (5.43 in.)
Bolt B	35 mm (1.38 in.)
Bolt C	70 mm (2.76 in.)

(c) Recheck the torque for bolts 1 and 2.

Torque: **21 N·m (214 kgf·cm, 15ft·lbf)**

(d) Wipe off any excess seal packing with a clean piece of cloth.

4. INSTALL OIL PUMP ASSEMBLY INFO

5. INSTALL NO. 2 OIL PAN SUB-ASSEMBLY INFO

6. INSTALL OIL PAN DRAIN PLUG

(a) Install a new gasket and the drain plug.

Torque: **37 N·m (377 kgf·cm, 27ft·lbf)**

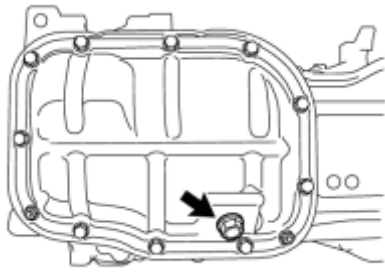

T

7. INSTALL ENGINE REAR OIL SEAL INFO

8. INSTALL CYLINDER BLOCK WATER DRAIN COCK SUB-ASSEMBLY

(a) Apply adhesive to the threads of the cylinder block water drain cock.

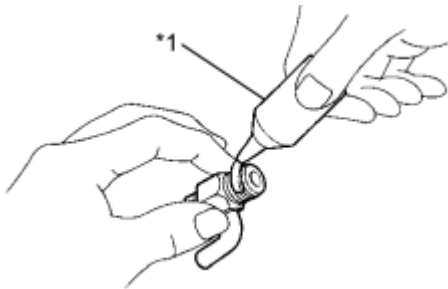

Text in Illustration

*1	Adhesive
----	----------

Adhesive:

Toyota Genuine Adhesive 1344, Three Bond 1344 or equivalent

(b) Install the drain cock as shown in the illustration.

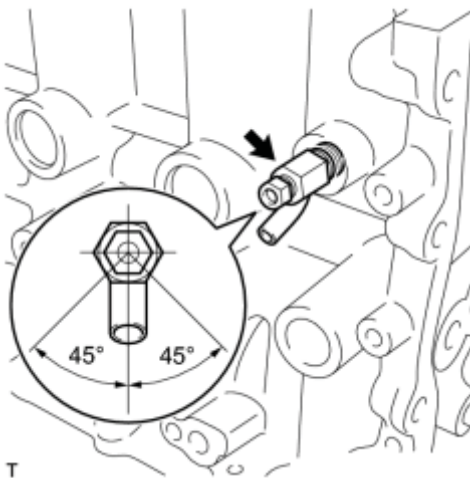

T

Torque: 25 N·m (255 kgf·cm, 18ft·lbf)

- Do not rotate the drain cock more than 1 revolution (360°) after tightening it to the specified torque.
- Do not loosen the drain cock to adjust it. If an adjustment is necessary, remove the drain cock and reinstall it.
- Install the drain cock within 3 minutes of applying adhesive.
- Do not start the engine for at least 1 hour after installing the drain cock.

(c) Install the drain cock plug to the drain cock.

Torque: 13 N·m (130 kgf·cm, 9ft·lbf)

9. INSTALL NO. 1 TAPER SCREW PLUG

(a) Apply adhesive to 2 or 3 threads of the taper screw plug.

Text in Illustration

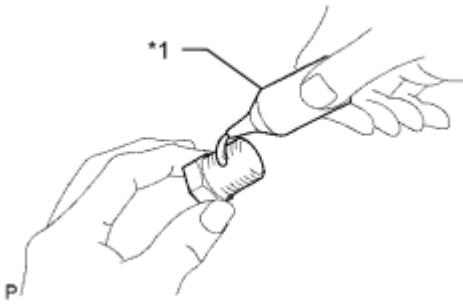

*1	Adhesive
----	----------

Adhesive:

Toyota Genuine Adhesive 1324, Three Bond 1324 or equivalent

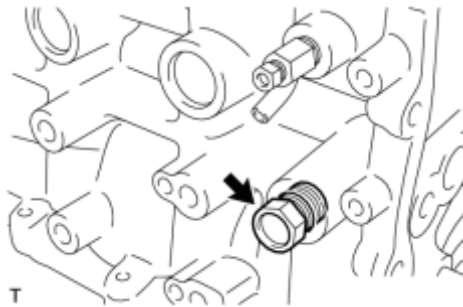

(b) Install the taper screw plug.

Torque: **43 N·m (438 kgf·cm, 32ft·lbf)**

- Install the plug within 3 minutes of applying adhesive.
- Do not start the engine for at least 1 hour after installation.

10. INSTALL VENTILATION VALVE SUB-ASSEMBLY

(a) Apply adhesive to the threads of the ventilation valve sub-assembly.

Text in Illustration

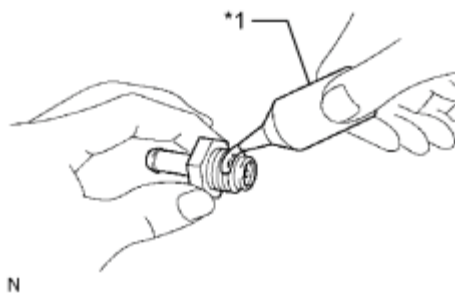

*1	Adhesive
----	----------

Adhesive:

Toyota Genuine Adhesive 1324, Three Bond 1324 or equivalent

- Install the ventilation valve sub-assembly within 3 minutes after applying seal packing.
- Do not start the engine for at least 2 hours after installing the ventilation valve sub-assembly.

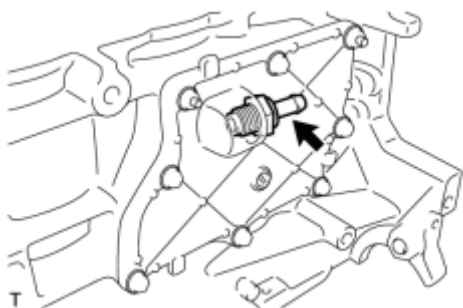

(b) Install the ventilation valve sub-assembly.

Torque: **20 N·m (204 kgf·cm, 15ft·lbf)**

11. INSTALL CYLINDER HEAD GASKET INFO

12. INSTALL CYLINDER HEAD SUB-ASSEMBLY INFO

13. INSTALL VALVE STEM CAP

- (a) Apply a light coat of engine oil to the valve stem ends.
- (b) Install the 16 valve stem caps to the cylinder head.

NOTICE:

Do not drop the valve stem caps into the cylinder head.

14. INSTALL VALVE LASH ADJUSTER ASSEMBLY

- (a) Inspect each valve lash adjuster before installing it INFO.
- (b) Install the 16 valve lash adjusters to the cylinder head.

NOTICE:

Install the valve lash adjuster to the same place it was removed from.

15. INSTALL NO. 1 VALVE ROCKER ARM SUB-ASSEMBLY

- (a) Apply engine oil to the valve lash adjuster tips and valve stem cap ends.

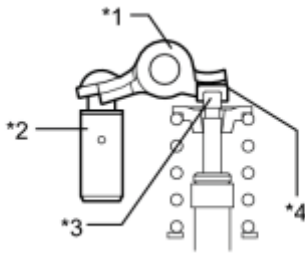

Text in Illustration

*1	Valve Rocker Arm
*2	Valve Lash Adjuster
*3	Valve Stem
*4	Valve Stem Cap

- (b) Make sure that the No. 1 valve rocker arms are installed as shown in the illustration.

16. INSTALL CAMSHAFT HOUSING STRAIGHT PIN

NOTICE:

It is not necessary to remove a straight pin unless it is being replaced.

- (a) Using a plastic-faced hammer, tap in a new straight pin to the specified protrusion height.

Text in Illustration

*a	Width
*b	Height

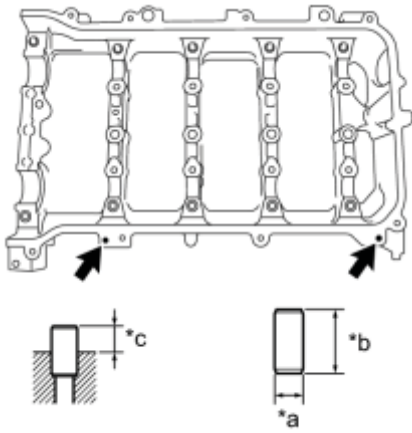

*c	Protrusion Height
----	-------------------

Standard Straight Pin:

Item	Protrusion Height	Height	Width
Straight pin	6.5 to 7.5 mm (0.256 to 0.295 in.)	14 mm (0.551 in.)	6.0 mm (0.236 in.)

17. INSTALL NO. 1 CAMSHAFT BEARING [INFO](#)

18. INSTALL OIL CONTROL VALVE FILTER

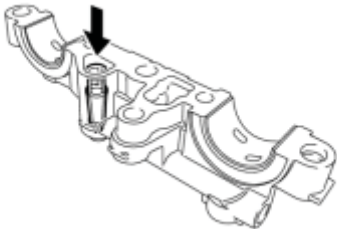

(a) Check that no foreign matter is on the mesh part of the oil control valve filter.

(b) Install the oil control valve filter.

NOTICE:

Do not touch the mesh when installing the oil control valve filter.

19. INSTALL NO. 2 CAMSHAFT BEARING [INFO](#)

20. INSTALL NO. 2 CAMSHAFT [INFO](#)

21. INSTALL CAMSHAFT [INFO](#)

22. INSTALL CAMSHAFT BEARING CAP [INFO](#)

23. INSTALL CAMSHAFT HOUSING SUB-ASSEMBLY [INFO](#)

24. INSTALL CAMSHAFT TIMING SPROCKET [INFO](#)

25. INSTALL CAMSHAFT TIMING GEAR ASSEMBLY [INFO](#)

26. INSTALL CRANKSHAFT TIMING GEAR KEY

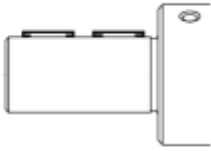

(a) Using a plastic-faced hammer, tap in the 2 crankshaft timing gear keys.

HINT:

Tap in the crankshaft timing gear keys until they contact the crankshaft as shown in the illustration.

27. INSTALL NO. 1 CRANKSHAFT POSITION SENSOR PLATE

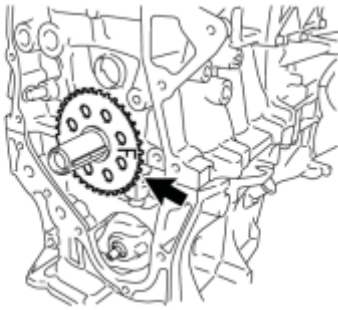

(a) Install the crankshaft position sensor plate with the "F" mark facing forward.

T

28. INSTALL NO. 2 CHAIN SUB-ASSEMBLY [INFO](#)

29. INSTALL CRANKSHAFT TIMING SPROCKET [INFO](#)

30. INSTALL NO. 1 CHAIN VIBRATION DAMPER [INFO](#)

31. SET NO. 1 CYLINDER TO TDC/COMPRESSION [INFO](#)

32. INSTALL CHAIN SUB-ASSEMBLY [INFO](#)

33. CHECK NO. 1 CYLINDER TO TDC/COMPRESSION [INFO](#)

34. INSTALL CHAIN TENSIONER SLIPPER [INFO](#)

35. INSTALL NO. 2 CHAIN VIBRATION DAMPER [INFO](#)

36. INSTALL INLET WATER SUB-ASSEMBLY STUD BOLT

NOTICE:

If a stud bolt is deformed or the threads are damaged, replace it.

(a) Using an E5 "TORX" socket wrench, install the stud bolts as shown in the illustration.

Torque: **5.0 N·m (51 kgf·cm, 44in·lbf)**

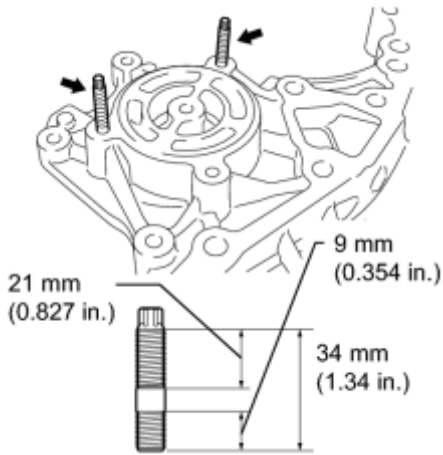

c

37. INSTALL INLET WATER SUB-ASSEMBLY

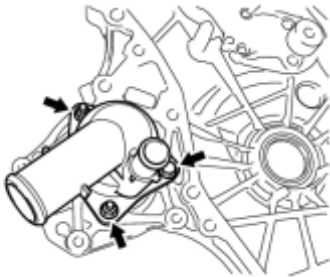

(a) Install a new gasket and the inlet water sub-assembly with the bolt and 2 nuts.

Torque: **10 N·m (102 kgf·cm, 7ft·lbf)**

c

38. INSTALL TIMING CHAIN COVER SUB-ASSEMBLY_ [INFO](#)

39. INSTALL TIMING CHAIN COVER OIL SEAL_ [INFO](#)

40. INSTALL CRANKSHAFT PULLEY_ [INFO](#)

41. INSTALL NO. 1 CHAIN TENSIONER ASSEMBLY_ [INFO](#)

42. INSTALL OIL FILTER CAP ASSEMBLY_ [INFO](#)

43. INSTALL SPARK PLUG TUBE GASKET

(a) Using a cutter knife, cut off the seal part of the removed gasket.



Text in Illustration

	Part to Cut Off
---	-----------------

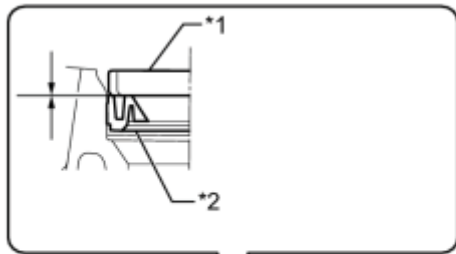

(b) Using a hammer and the plug tube gasket which has had the sealing part cut off, uniformly tap in a new plug tube gasket all the way.

Text in Illustration

*1	Plug Tube Gasket without Sealing Part
*2	New Plug Tube Gasket

- Keep the lip free of foreign matter.
- Do not tap in the plug tube gasket.

HINT:

If a plug tube gasket that will be used to install a new gasket is deformed, and cannot be positioned on a new gasket, correct the deformation using pliers.

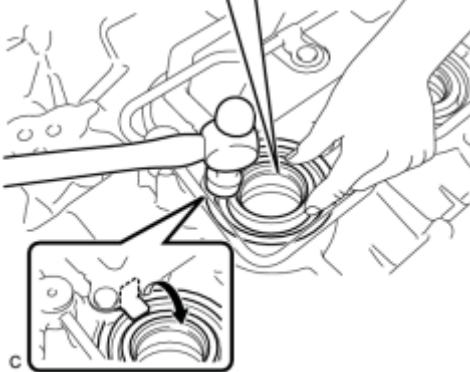

(c) Return the claws of the ventilation baffle plate to their original positions.

44. INSTALL CYLINDER HEAD COVER GASKET

(a) Install a new cylinder head cover gasket to the cylinder head cover.

Text in Illustration

*1	Cylinder Head Cover
*2	Cylinder Head Cover Gasket

- Remove any oil from the contact surfaces.
- Misalignment between the center of the cylinder head cover rib

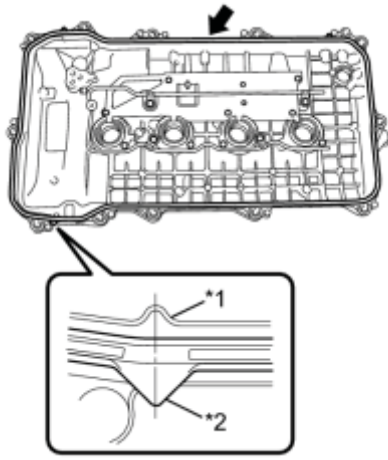

and the center of the cylinder head gasket tab is within 4 mm (0.157 in.).

c

45. INSTALL CYLINDER HEAD COVER SUB-ASSEMBLY

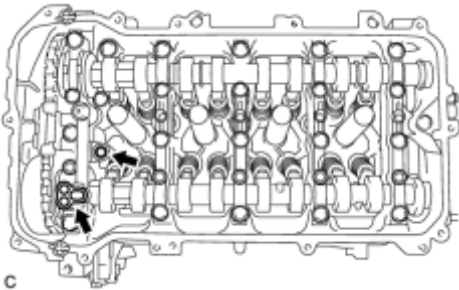

(a) Install 2 new gaskets to the camshaft bearing cap.

c

(b) Apply seal packing as shown the illustration.

Seal packing:

Toyota Genuine Seal Packing Black, Three Bond 1207B or equivalent

Standard diameter:

4.0 mm (0.157 in.)

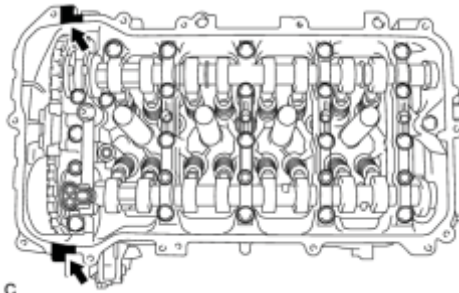

c

- Remove any oil from the contact surfaces.
- Install the cylinder head cover sub-assembly within 3 minutes and tighten the bolts within 15 minutes of applying seal packing.
- Do not start the engine for at least 2 hours after the installation.

(c) Install the cylinder head cover with a new seal washer and the 13 bolts.

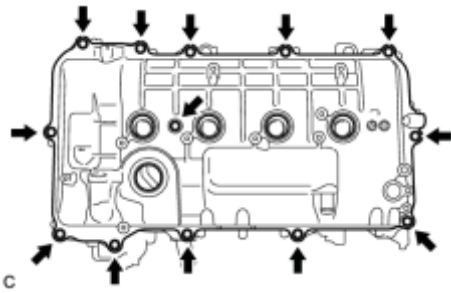

Torque: 10 N·m (102 kgf·cm, 7ft·lbf)

NOTICE:

Misalignment between the contact surfaces of the timing chain cover and the camshaft housing and the center of the cylinder head gasket tab is within 4 mm (0.157 in.).

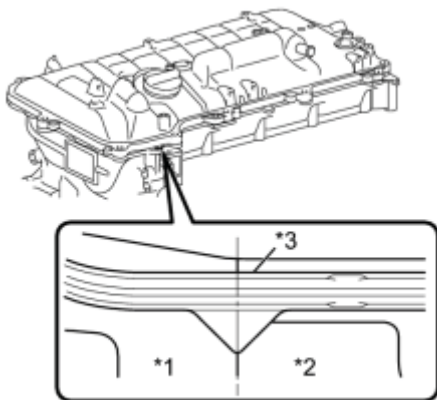

c

Text in Illustration

*1	Timing Chain Cover
*2	Camshaft Housing
*3	Cylinder Head Cover Gasket

46. INSTALL ENGINE OIL PRESSURE SWITCH ASSEMBLY

(a) Apply adhesive to 2 or 3 threads of the engine oil pressure switch assembly.

Text in Illustration

*1	Adhesive
----	----------

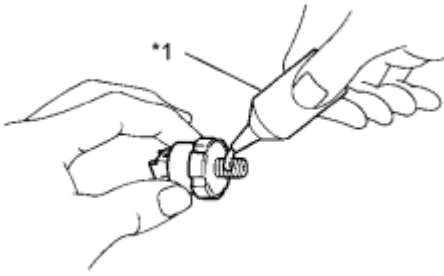

Adhesive:

Toyota Genuine Adhesive 1344, Three Bond 1344 or equivalent

- Install the oil pressure switch within 3 minutes after applying adhesive.
- Do not start the engine within 1 hour after installation.

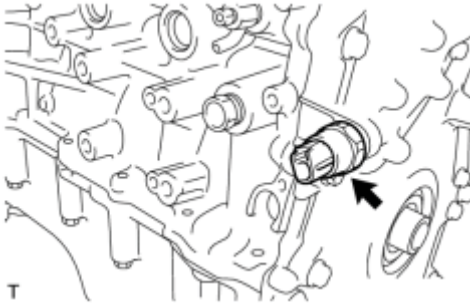

(b) Using a 24 mm deep socket wrench, install the engine oil pressure switch assembly.

Torque: **15 N·m (153 kgf·cm, 11ft·lbf)**

47. INSTALL ENGINE COOLANT TEMPERATURE SENSOR

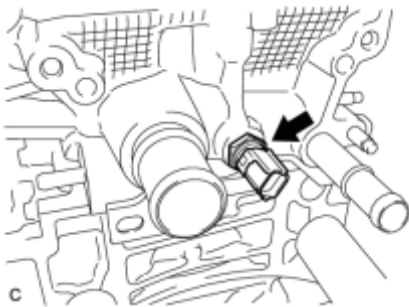

(a) Install a new gasket and the engine coolant temperature sensor.

Torque: **20 N·m (204 kgf·cm, 15ft·lbf)**

48. INSTALL KNOCK SENSOR

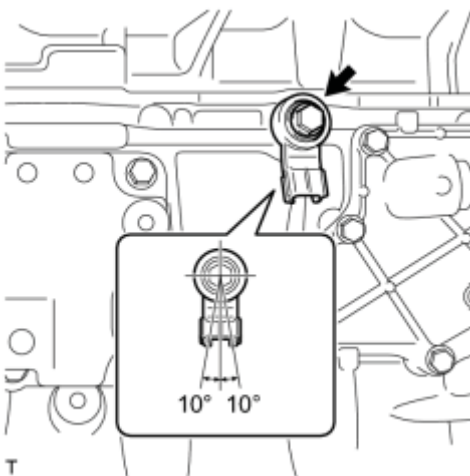

(a) Install the knock sensor with the bolt.

Torque: **21 N·m (214 kgf·cm, 15ft·lbf)**

NOTICE:

Make sure that the knock sensor is in the correct position.

49. INSTALL CRANKSHAFT POSITION SENSOR

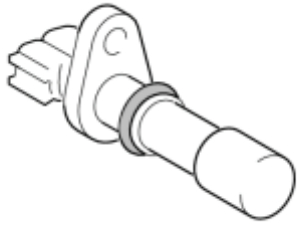

(a) Apply a light coat of engine oil to the O-ring of the sensor.

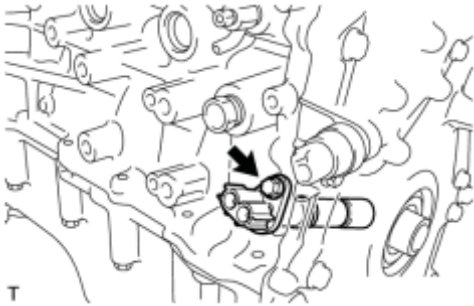

(b) Install the crankshaft position sensor with the bolt.

Torque: **10 N·m (102 kgf·cm, 7ft·lbf)**

50. INSTALL CAMSHAFT TIMING OIL CONTROL VALVE ASSEMBLY

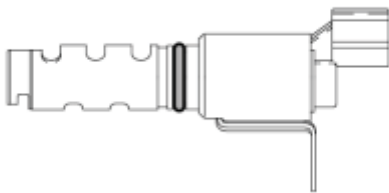

(a) Apply a light coat of engine oil to a new O-ring and install it to the camshaft timing oil control valve.

P

(b) Install the camshaft timing oil control valve with the bolt.

Torque: **10 N·m (102 kgf·cm, 7ft·lbf)**

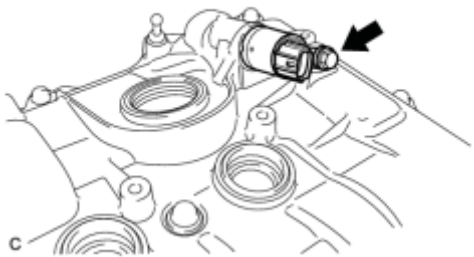

- Do not allow foreign matter to contact the oil seal face of the oil control valve (connecting surface with cylinder head cover).
- Be careful that the O-ring is not cracked or moved out of place when installing the oil control valve.

51. INSTALL CAMSHAFT POSITION SENSOR

(a) Apply a light coat of engine oil to the O-ring of the sensor.

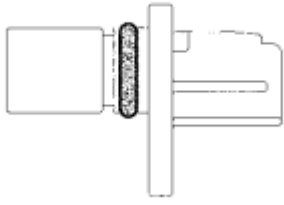

P

(b) Install the camshaft position sensor with the bolt.

Torque: **10 N·m (102 kgf·cm, 7ft·lbf)**

NOTICE:

Make sure that the O-ring is not cracked or jammed when installing the sensor.

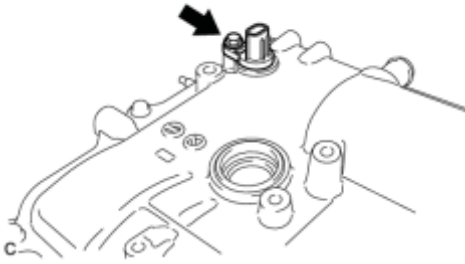

52. INSTALL SPARK PLUG INFO

53. INSTALL ENGINE COVER JOINT BOLT

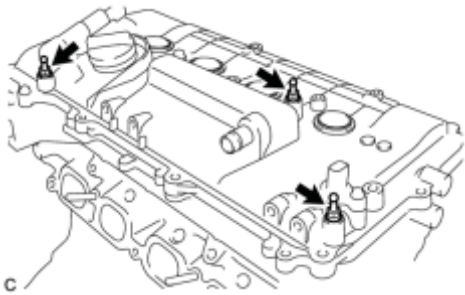

(a) Install the 3 engine cover joint bolts.

Torque: **10 N·m (102 kgf·cm, 7ft·lbf)**

54. INSTALL WIRING HARNESS CLAMP BRACKET

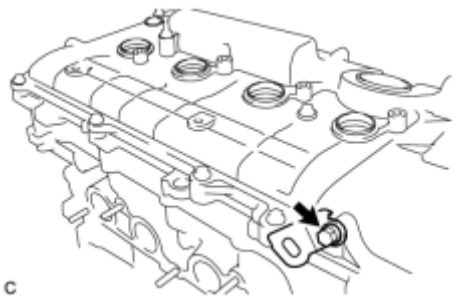

(a) Install the wiring harness clamp bracket with the bolt.

Torque: **10 N·m (102 kgf·cm, 7ft·lbf)**

55. INSTALL OIL FILLER CAP GASKET

(a) Install the gasket to the oil filler cap.

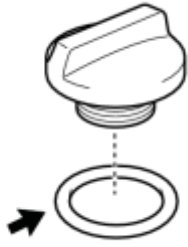

T

56. INSTALL OIL FILLER CAP SUB-ASSEMBLY

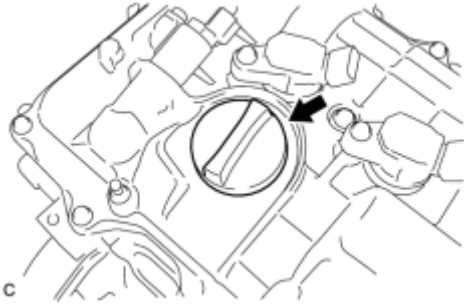

(a) Install the oil filler cap.

INSTALLATION

1. INSTALL IGNITION COIL ASSEMBLY_ INFO

2. INSTALL VENTILATION HOSE

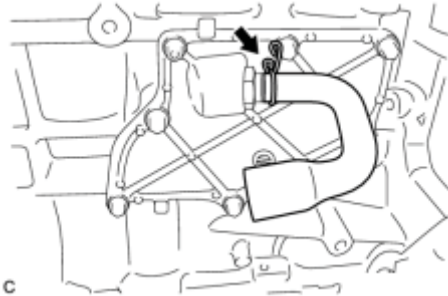

(a) Install the ventilation hose to the ventilation valve.

3. INSTALL EXHAUST MANIFOLD_ INFO

4. INSTALL MANIFOLD STAY_ INFO

5. INSTALL NO. 1 EXHAUST MANIFOLD HEAT INSULATOR_ INFO

6. INSTALL FUEL INJECTOR ASSEMBLY_ INFO

7. INSTALL NO. 1 DELIVERY PIPE SPACER_ INFO

8. INSTALL FUEL DELIVERY PIPE SUB-ASSEMBLY_ INFO

9. INSTALL FUEL VAPOR FEED PIPE

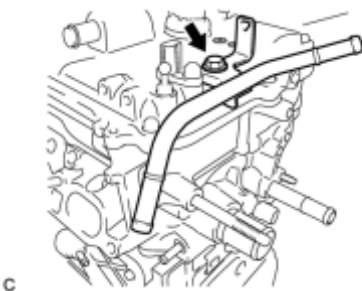

(a) Install the fuel vapor feed pipe with the bolt.

Torque: **21 N·m (214 kgf·cm, 15ft·lbf)**

10. INSTALL INTAKE MANIFOLD_ INFO

11. INSTALL EGR WITH COOLER PIPE SUB-ASSEMBLY_ INFO

12. INSTALL EGR VALVE ASSEMBLY_ INFO

13. INSTALL EGR PIPE ASSEMBLY_ INFO

14. INSTALL ENGINE OIL LEVEL DIPSTICK GUIDE

- (a) Apply a light coat of engine oil to a new O-ring.
- (b) Install the O-ring to the engine oil level dipstick guide.

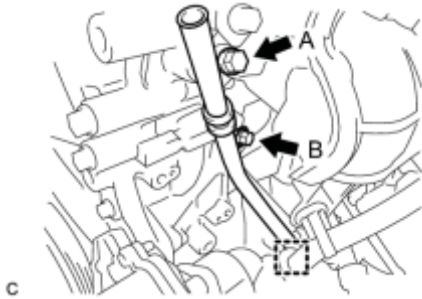

- (c) Install the engine oil level dipstick guide with the 2 bolts.

Bolt A - Torque: **28 N·m (286 kgf·cm, 21ft·lbf)**

Bolt B - Torque: **21 N·m (214 kgf·cm, 15ft·lbf)**

- (d) Connect the clamp to the engine oil level dipstick guide.

- (e) Install the oil dipstick.

15. INSTALL THROTTLE BODY ASSEMBLY_ INFO

16. INSTALL ENGINE HANGERS

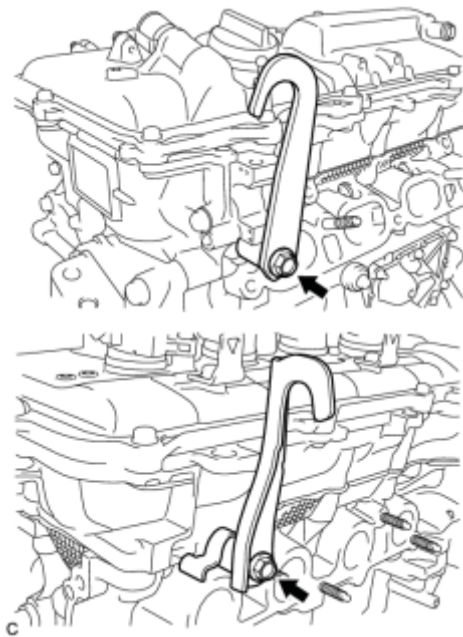

- (a) Install the 2 engine hangers with the 2 bolts.

Torque: **43 N·m (438 kgf·cm, 32ft·lbf)**

Part Name	Part No.
No. 1 engine hanger	12281-37021
No. 2 engine hanger	12282-37011
Bolt	91552-81050

17. REMOVE ENGINE ON ENGINE STAND

(a) Remove the bolts and engine on engine stand.