

Your Current Vehicle: 2014 Toyota Prius V

Removal (2014 Prius V From 08/2013)

1. REMOVE SERVICE PLUG GRIP

2014 MY Prius V [08/2013 -]; HYBRID / BATTERY CONTROL: SERVICE PLUG GRIP: REMOVAL (?a=0&t=545483).

2. REMOVE NO. 1 ENGINE UNDER COVER

3. DRAIN COOLANT (for Inverter) 2014 MY Prius V [08/2013 -]; HYBRID / BATTERY CONTROL: COOLANT (for Inverter): REPLACEMENT+ (?a=0&t=543909)

4. REMOVE RADIATOR SUPPORT OPENING COVER 2014 MY Prius V [08/2013 -]; EXTERIOR PANELS / TRIM: FRONT BUMPER: REMOVAL+ (?a=0&t=545501)

5. REMOVE NO. 1 INVERTER BRACKET

- Remove the 3 bolts and No. 1 inverter bracket.

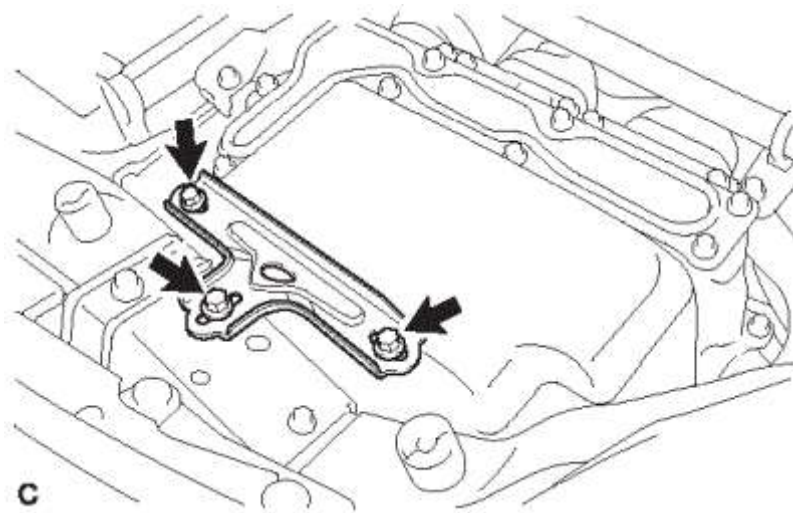

Click to Enlarge

6. DISCONNECT ENGINE ROOM MAIN WIRE

NOTE

- Insulate the disconnected terminals with insulating tape.
- Cover the hole where the cable was connected with tape or equivalent (non-residue

type) to prevent entry of foreign matter.

- To prevent damage due to static electricity, do not touch the terminals of the disconnected connectors.
- Raise the lock lever and disconnect the inverter with converter connector.

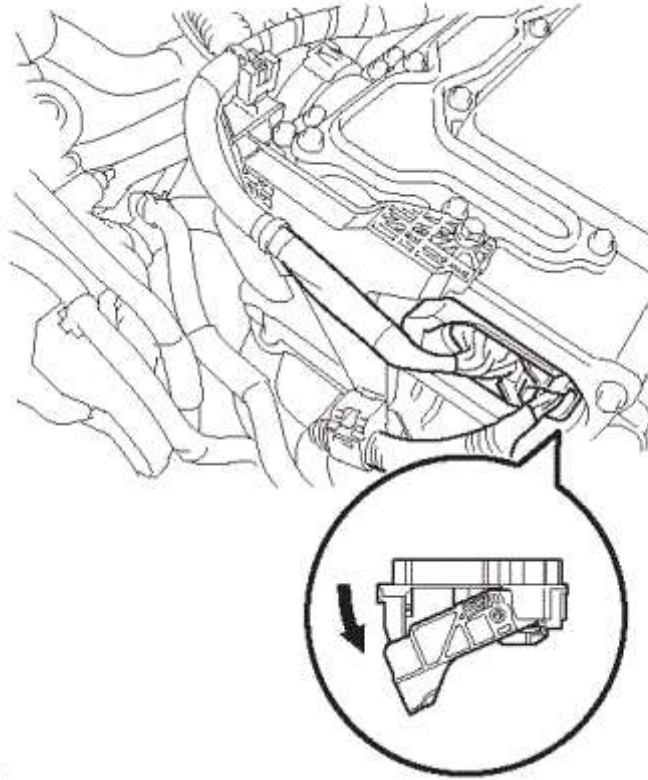

c

[Click to Enlarge](#)

- Disconnect the engine wire from the engine room main wire.

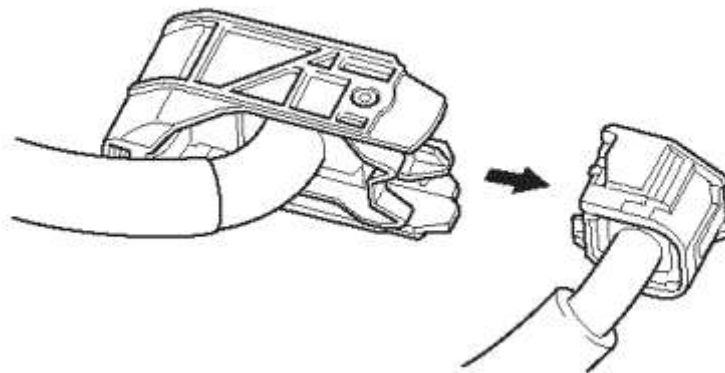

c

[Click to Enlarge](#)

- Remove the bolt.



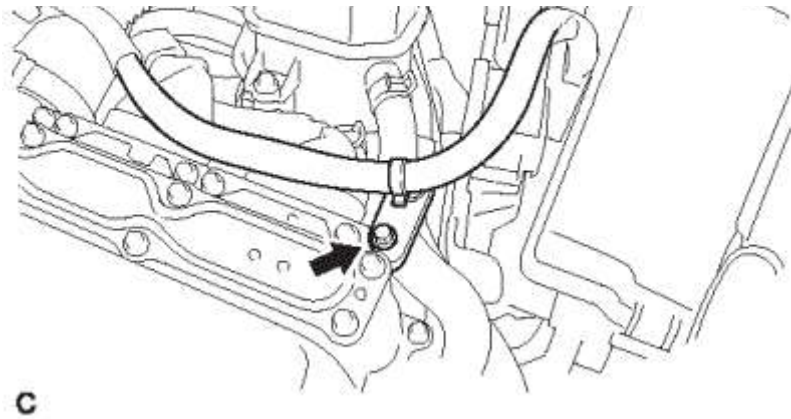

Click to Enlarge

- Remove the bolt from the engine room main wire.

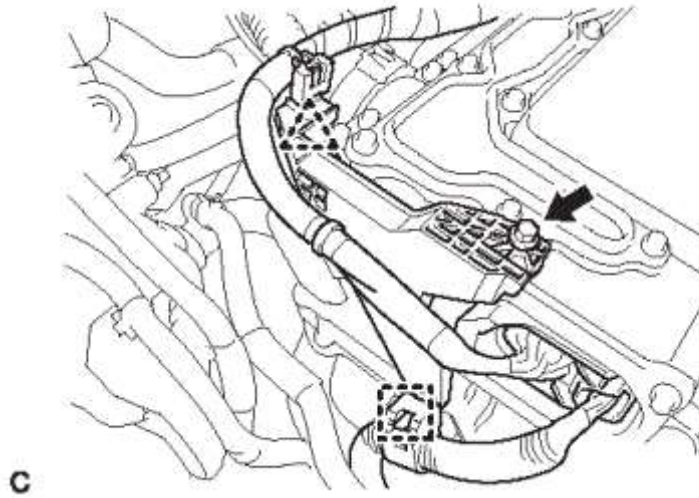

Click to Enlarge

- Disconnect the clamp and clip, and separate the engine room main wire.

7. REMOVE INVERTER COVER

WARNING

Wear insulated gloves.

- Remove the 9 bolts and inverter cover.

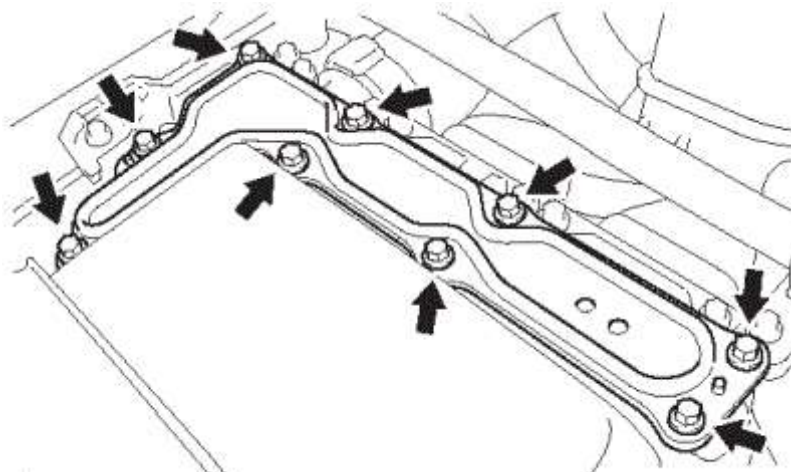

Click to Enlarge

NOTE

Make sure to pull the inverter cover straight up, as a connector is connected to the bottom of the cover.

8. CHECK TERMINAL VOLTAGE

WARNING

Wear insulated gloves.

NOTE

Do not allow any foreign matter or water to enter the inverter with converter assembly.

- Using a voltmeter, measure the voltage between the terminals of the 2 phase connectors.

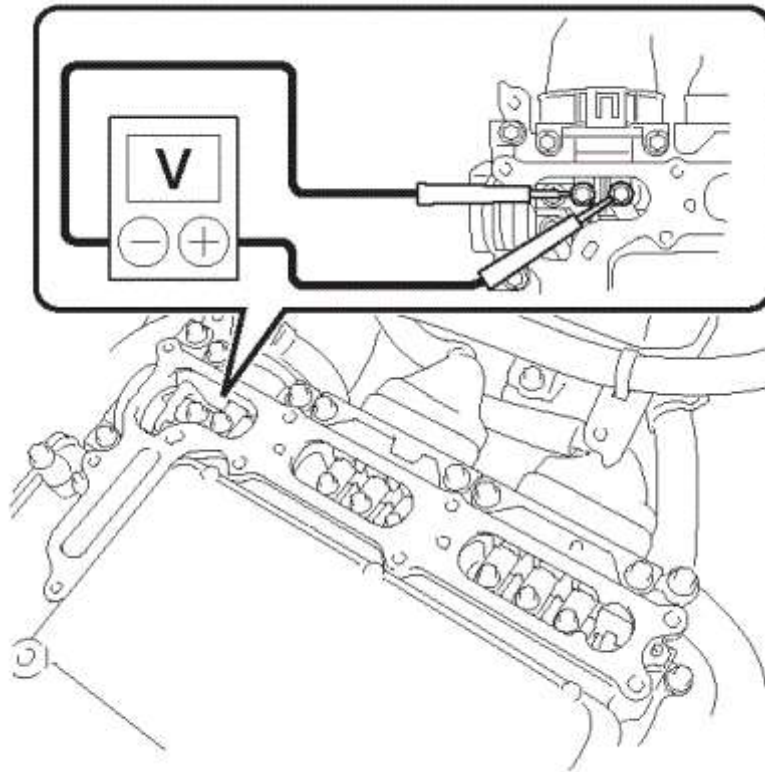

Click to Enlarge

Standard voltage

0 V

NOTE

HINT:

Use measuring range of DC 750 V or more on the voltmeter.

9. DISCONNECT FRAME WIRE

WARNING

Wear insulated gloves.

NOTE

- Insulate the disconnected terminals with insulating tape.
- Cover the hole where the cable was connected with tape or equivalent (non-residue type) to prevent entry of foreign matter.
- Disconnect the harness clamp.

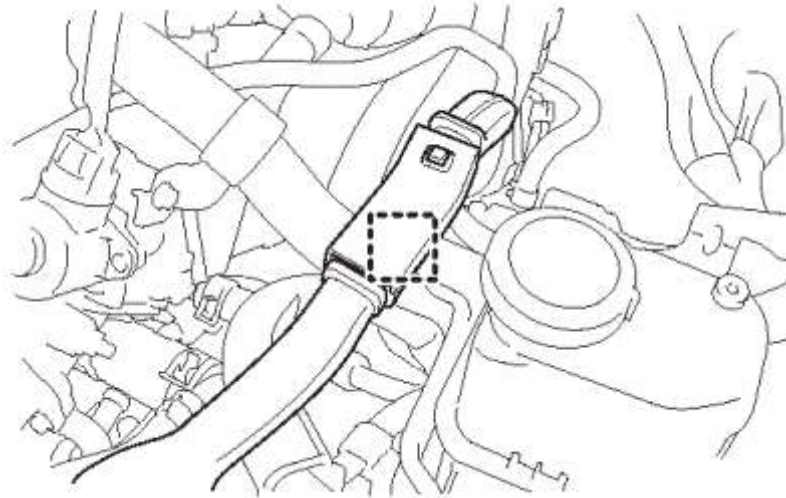

Click to Enlarge

- Remove the 4 bolts, and disconnect the frame wire (high voltage cables of the hybrid battery) from the inverter with converter assembly.

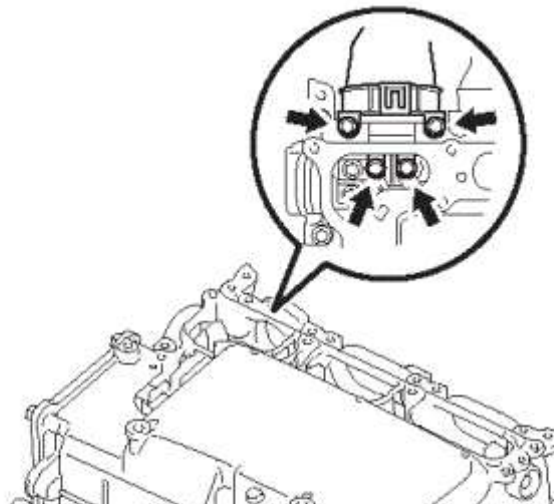

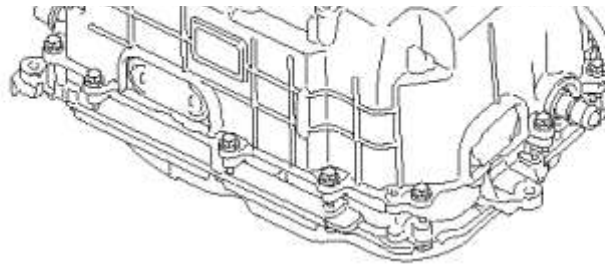

Click to Enlarge

10. DISCONNECT GENERATOR CABLE

WARNING

Wear insulated gloves.

NOTE

- Insulate the disconnected terminals with insulating tape.
- Cover the hole where the cable was connected with tape or equivalent (non-residue type) to prevent entry of foreign matter.
- Turn back the wire harness cover and release the generator cable.

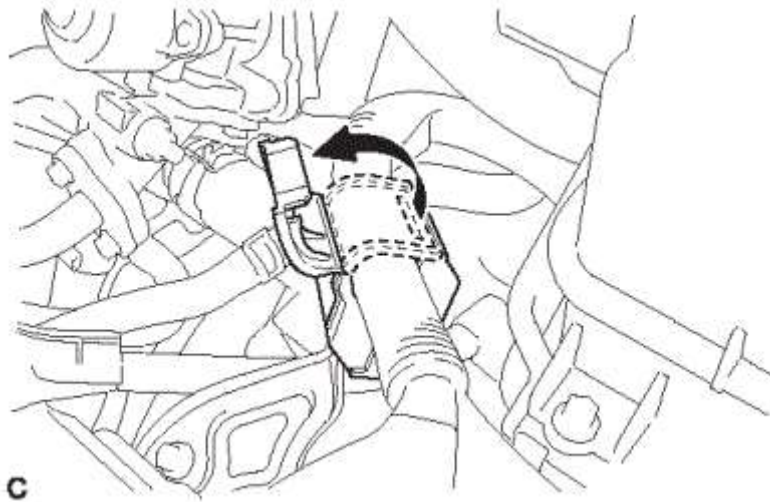

Click to Enlarge

- Remove the 5 bolts, and disconnect the high voltage cables of the generator cable (MG1) from the inverter with converter assembly.

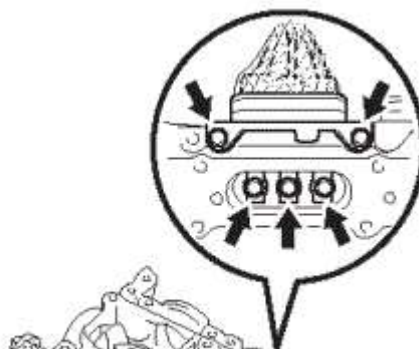

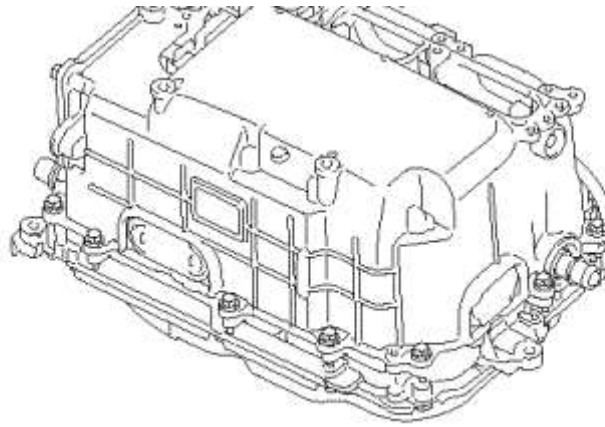

Click to Enlarge

11. DISCONNECT MOTOR CABLE

WARNING

Wear insulated gloves.

NOTE

- Insulate the disconnected terminals with insulating tape.
- Cover the hole where the cable was connected with tape or equivalent (non-residue type) to prevent entry of foreign matter.
- Disconnect the harness clamp.

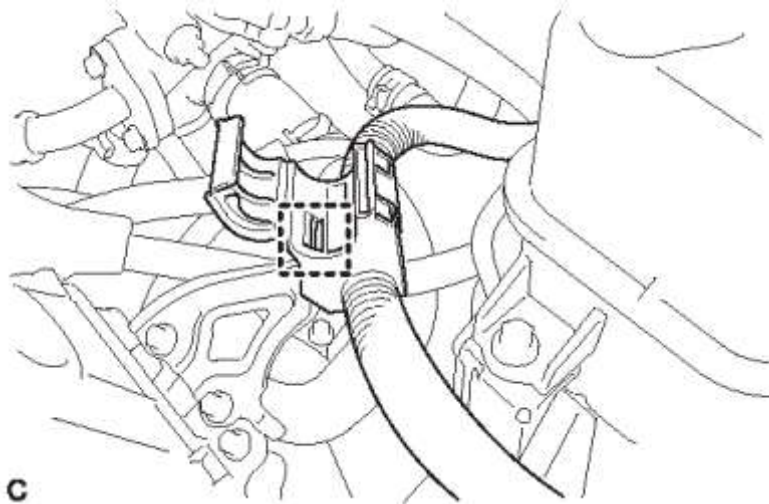

Click to Enlarge

- Remove the 5 bolts, and disconnect the high voltage cables of the motor cable (MG2) from the inverter with converter assembly.



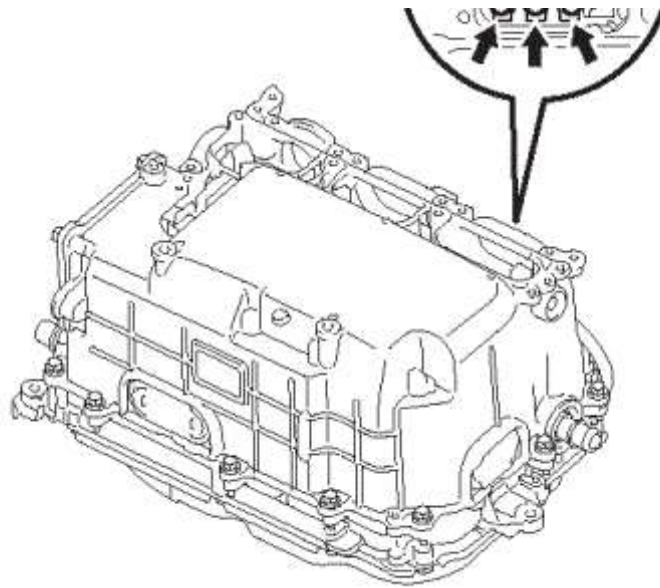

Click to Enlarge

12. DISCONNECT NO. 2 ENGINE WIRE

WARNING

Wear insulated gloves.

NOTE

- Insulate the disconnected terminals with insulating tape.
- Cover the hole where the cable was connected with tape or equivalent (non-residue type) to prevent entry of foreign matter.
- Remove the 4 bolts, and disconnect the No. 2 engine wire (high voltage cables for the air conditioning compressor) from the inverter with converter assembly.

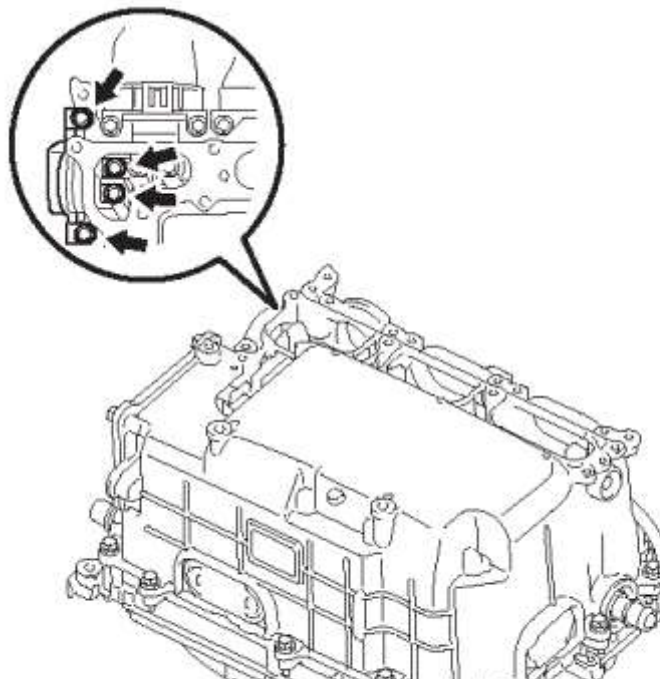



Click to Enlarge

- Disconnect the harness clamp.

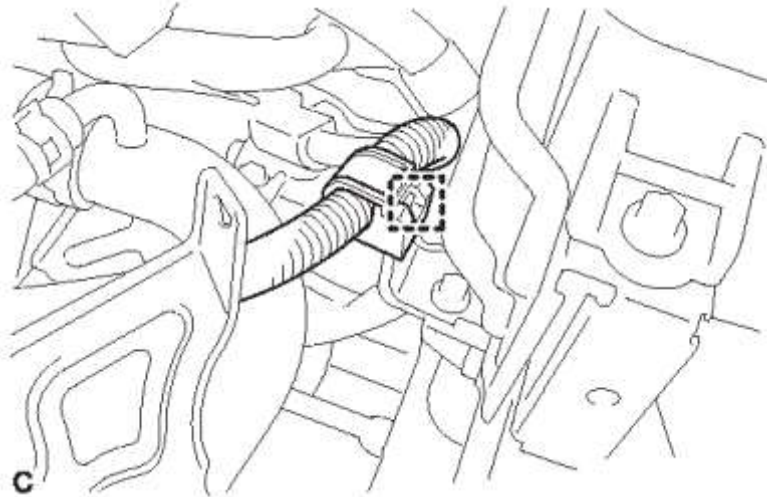

Click to Enlarge

13. INSTALL INVERTER COVER

WARNING

Wear insulated gloves.

- Temporarily install the inverter cover with the 9 bolts to prevent any foreign matter or water from entering the inverter with converter assembly.

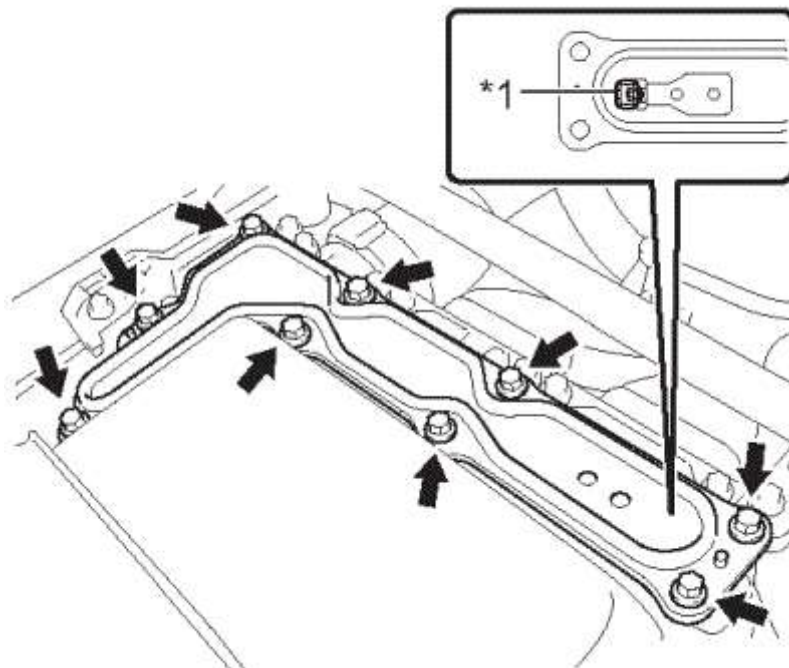

Click to Enlarge

Text in Illustration

*1	Interlock
----	-----------

NOTE

- Make sure that the interlock is fully engaged.
- Do not allow any foreign matter or water to enter the inverter with converter assembly.

14. DISCONNECT NO. 2 ENGINE ROOM WIRE

- Remove the relay block cover.
- Release the 2 clamps, and remove the No. 1 relay block cover.

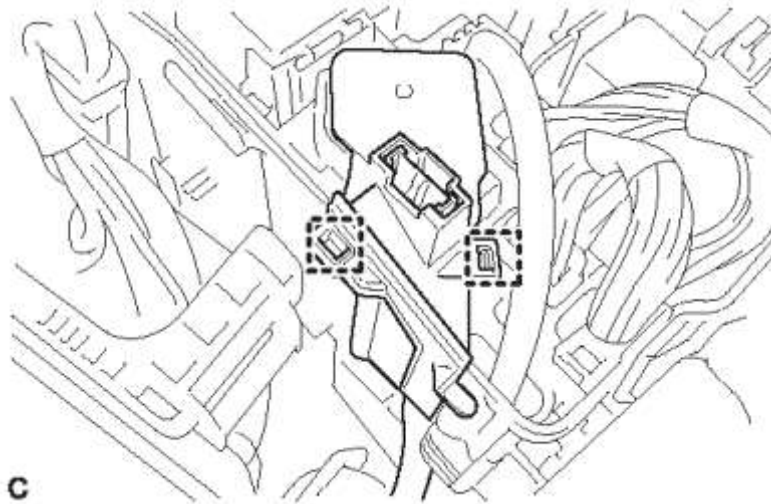

Click to Enlarge

- Remove the bolt from the No. 2 engine room wire.

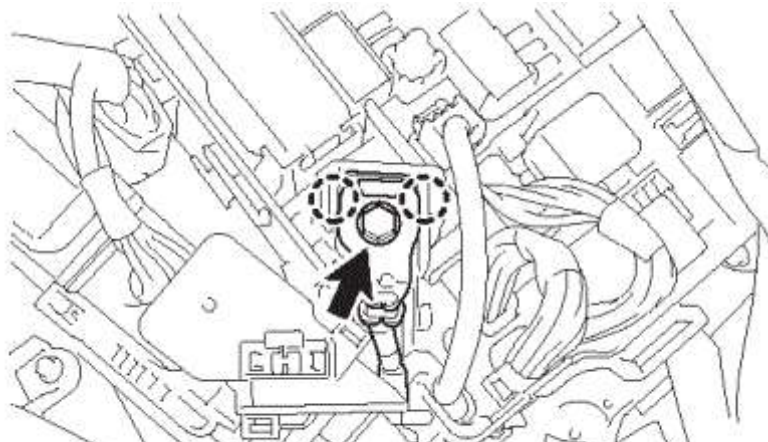



Click to Enlarge

- Release the 2 claws, and disconnect the No. 2 engine room wire.
- Connect the No. 2 engine room wire to the protector.

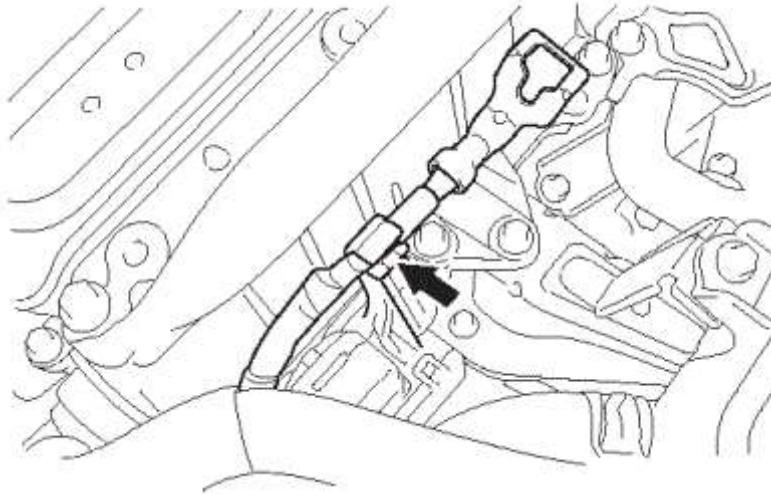

Click to Enlarge

15. DISCONNECT WATER HOSE

- Release the retainer and disconnect the water hose from the inverter with converter assembly.

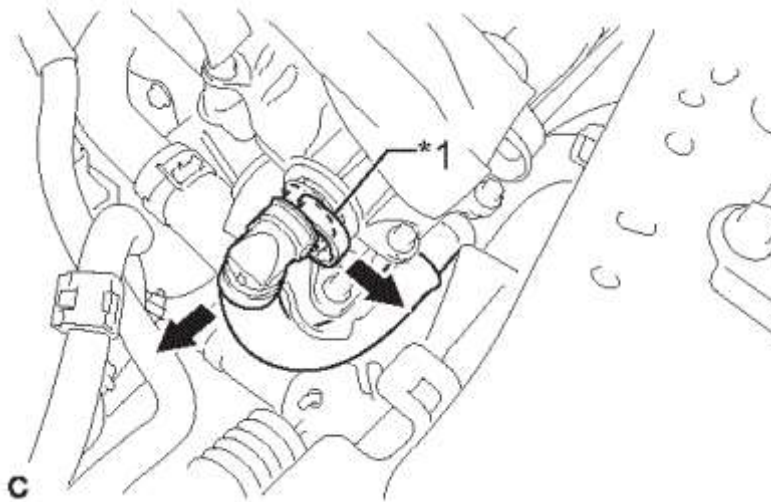

Click to Enlarge

Text in Illustration

*1	Retainer
----	----------

- Release the retainer and disconnect the water hose from the inverter with converter assembly.

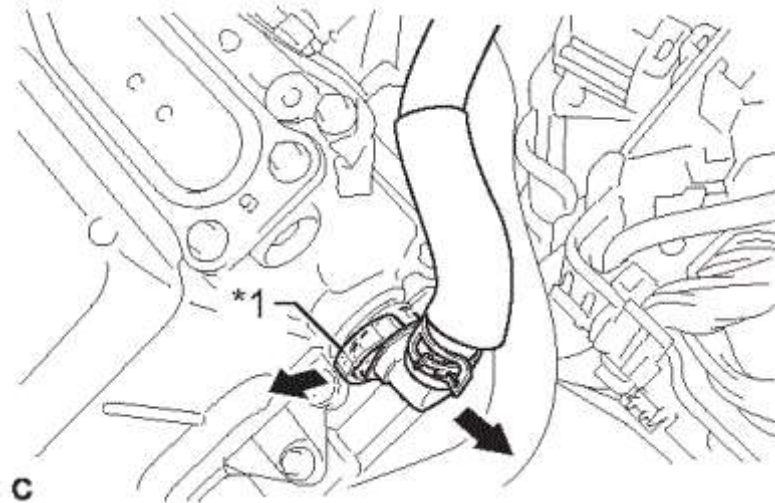

Click to Enlarge

Text in Illustration

*1	Retainer
----	----------

- Put pieces of cloth into the pipes and in the disconnected hoses, or cover the pipes and hoses with plastic bags as shown in the illustration to prevent foreign matter from entering the cooling system and to prevent coolant from spilling near the inverter with converter assembly.

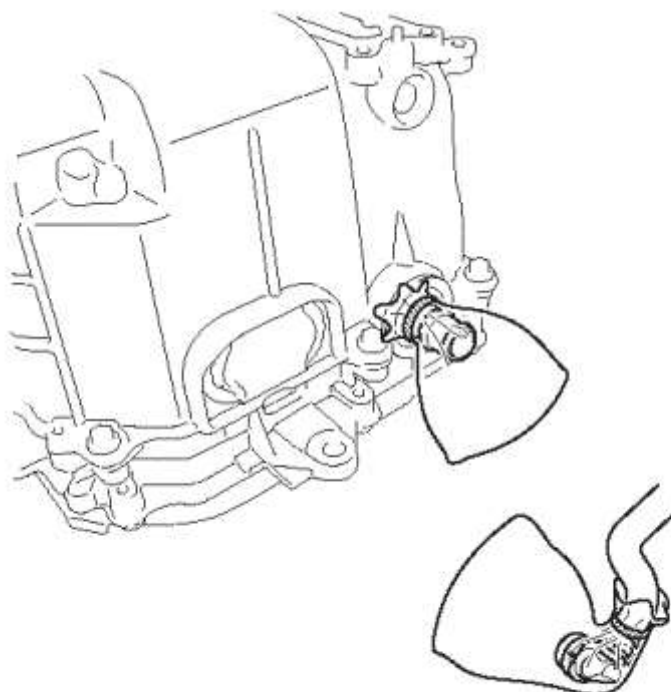

c

[Click to Enlarge](#)

16. REMOVE INVERTER WITH CONVERTER ASSEMBLY

WARNING

Wear insulated gloves.

- Remove the 3 bolts and inverter with converter assembly.

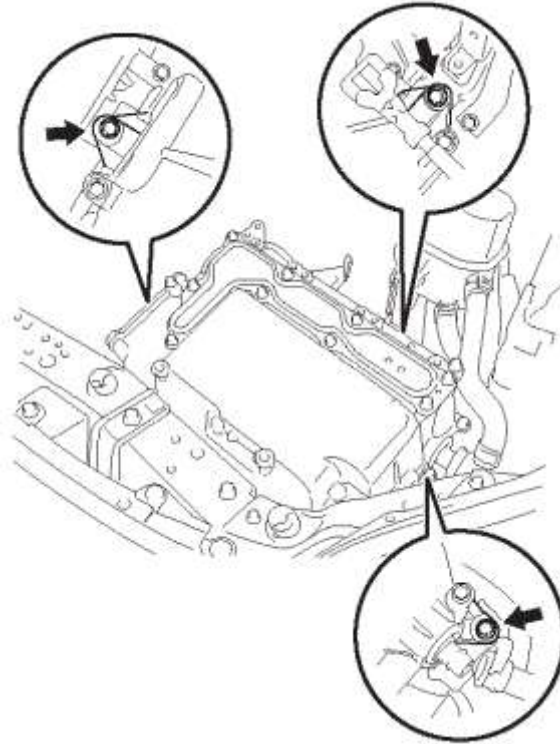

c

[Click to Enlarge](#)

NOTE

- Since the inverter with converter assembly is very heavy, 2 people are needed to remove the inverter with converter assembly. When removing the inverter with converter assembly, do not damage the parts around it.
 - To prevent damage, do not hold the inverter with converter assembly by the connectors.
 - To prevent damage due to static electricity, do not touch the terminals of the disconnected connectors.
- Even after the coolant is drained, coolant remains in the inverter due to its internal structure. Therefore, seal or cover the pipes when removing the inverter so that coolant does not spill out.

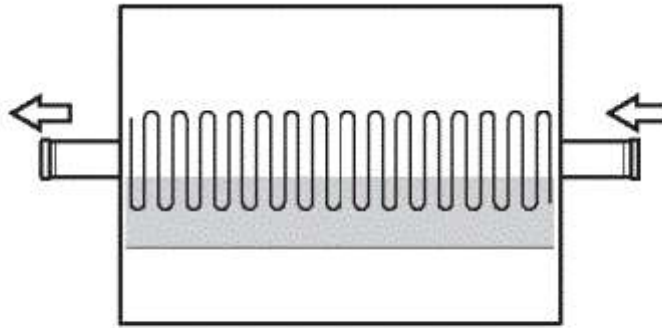

T

[Click to Enlarge](#)

17. REMOVE MOTOR CABLE BRACKET

- Remove the 2 bolts and motor cable bracket.

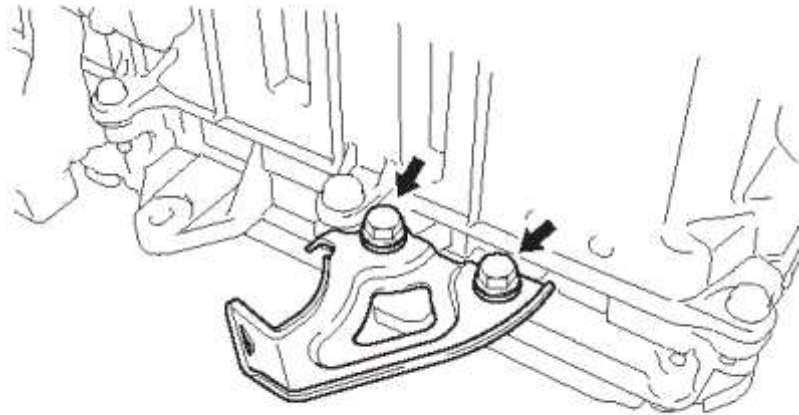

C

[Click to Enlarge](#)

18. REMOVE HIGH VOLTAGE FUSE

WARNING

Wear insulated gloves.

NOTE

HINT:

Perform this procedure only when replacement of the high voltage fuse is necessary.

- Remove the 9 bolts and inverter cover.



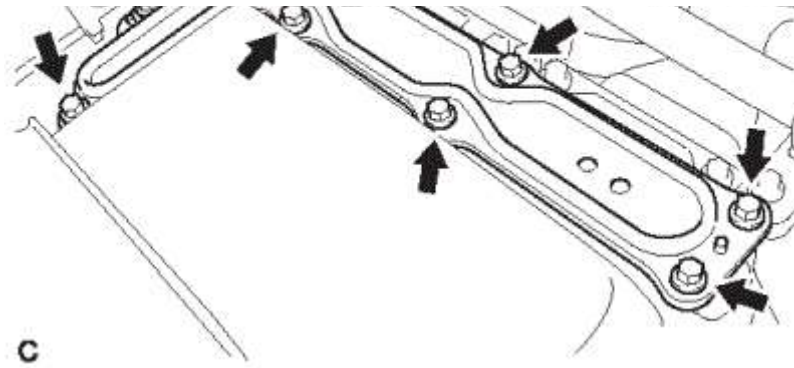

Click to Enlarge

NOTE

Make sure to pull the inverter cover straight up, as a connector is connected to the bottom of the cover.

- Remove the 2 bolts and high voltage fuse from the inverter with converter assembly.

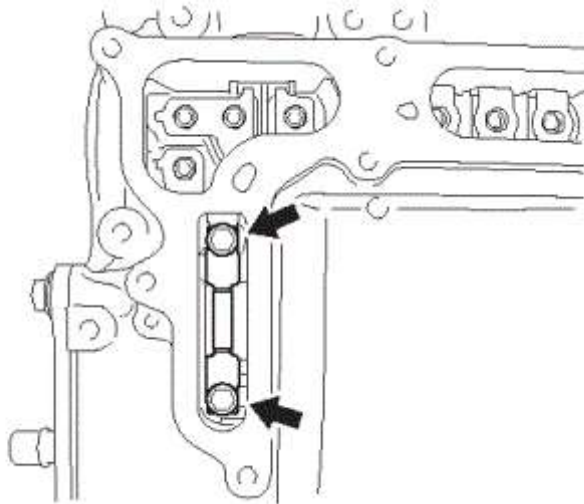

Click to Enlarge

NOTE

Do not allow any foreign matter or water to enter the inverter with converter assembly.

- Temporarily install the inverter cover with the 9 bolts to prevent any foreign matter or water from entering the inverter with converter assembly.

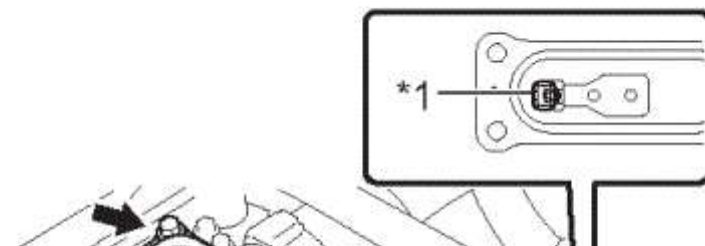

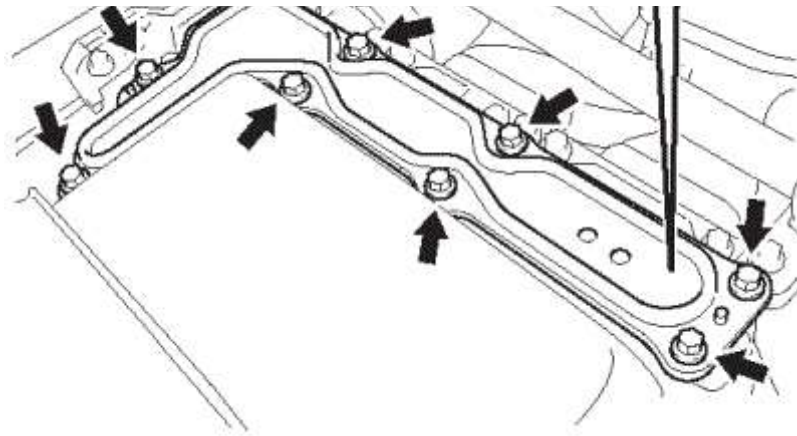

Click to Enlarge

Text in Illustration

*1	Interlock
----	-----------

NOTE

- Make sure that the interlock is fully engaged.
- Do not allow any foreign matter or water to enter the inverter with converter assembly.

19. REMOVE NO. 2 ENGINE ROOM WIRE

NOTE

HINT:

Perform this procedure only when replacement of the No. 2 engine room wire is necessary.

- Disengage the 2 claws and open the terminal cover.

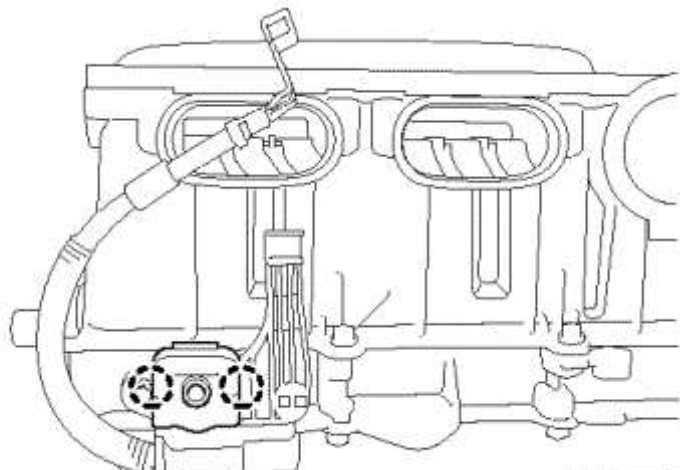

C

[Click to Enlarge](#)

- Remove the nut from the No. 2 engine room wire.

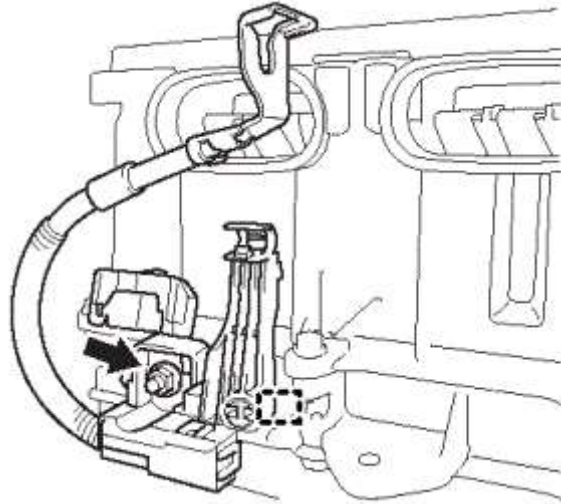

C

[Click to Enlarge](#)

- Disengage the clamp and remove the No. 2 engine room wire from the inverter with converter assembly.