

DRIVE BELT COMPONENTS

EM

DRIVE BELT



NO. 1 AIR CLEANER INLET

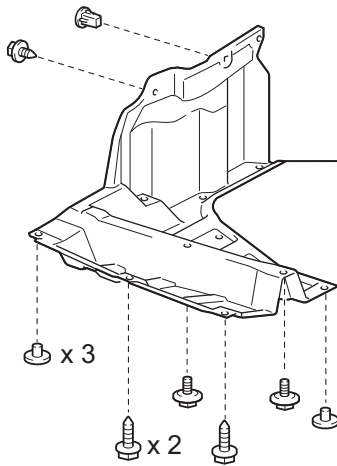
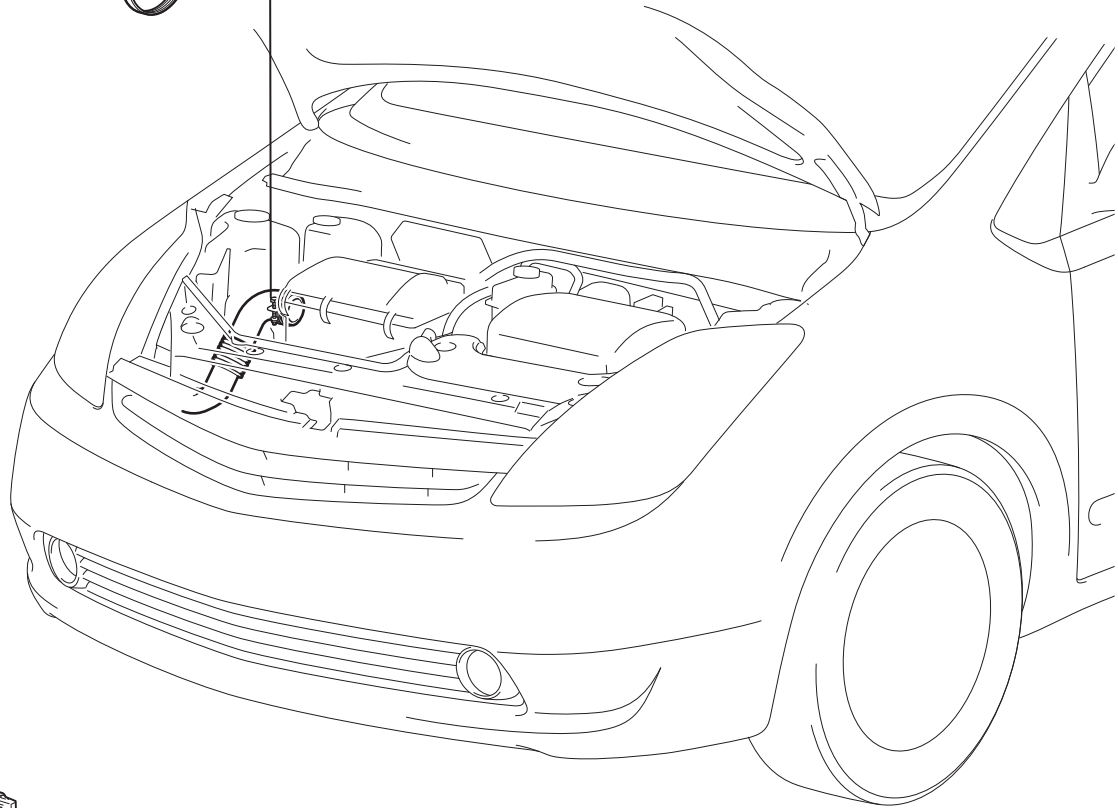

ENGINE UNDER COVER RH

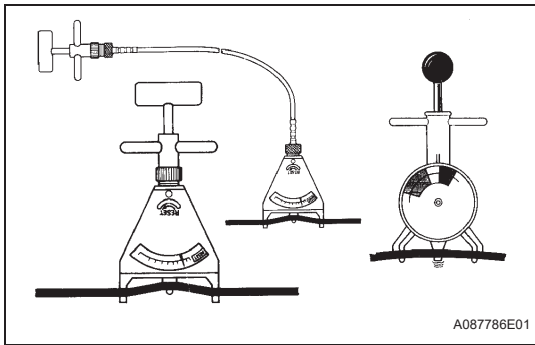

A087786E01

ON-VEHICLE INSPECTION

1. CHECK DRIVE BELT TENSION

- (a) Using a belt tension gauge, measure the belt tension.

Belt tension gauge:

DENSO BTG-20 (95506-00020)

Borroughs No. BT-33-73F

Standard drive belt tension

Item	Specified Condition
New belt	99 to 121 lbf
Used belt	55 to 77lbf

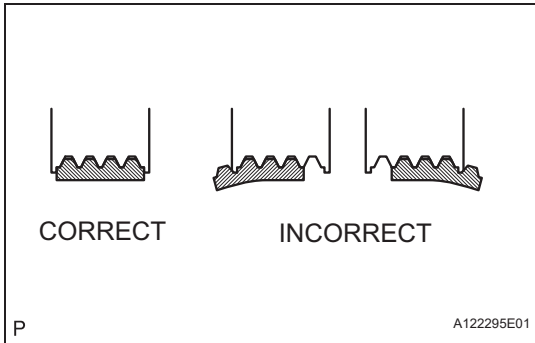

P

A122295E01

HINT:

- After installing the drive belt, check that it fits properly in the ribbed grooves. Check with your hands to confirm that the belt has not slipped out of the groove on the bottom of the crankshaft pulley.
- A "new belt" is a belt which has been used less than 5 minutes on a running engine.
- A "used belt" is a belt which has been used on a running engine for 5 minutes or more.
- After installing a new belt, run the engine for approximately 5 minutes and then recheck the tension.

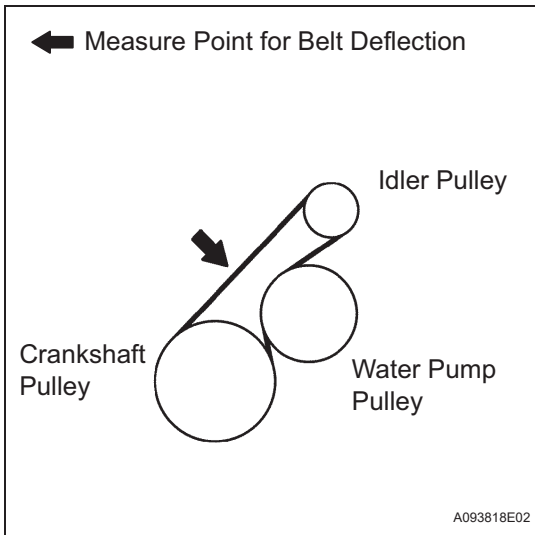

A093818E02

- (b) Reference:

Check the drive belt deflection.

- (1) When not using a belt tension gauge, measure the belt deflection.

Pressing force: 98 N (10 kgf, 22 lbf)

Standard belt deflection

Item	Specified Condition
New belt	9.0 to 12.0 mm (0.35 to 0.47 in.)
Used belt	11 to 15 mm (0.43 to 0.59 in.)

NOTICE:

- Check the drive belt deflection at the specified point.
- When installing a new belt, set its tension value as specified.
- When inspecting a belt which has been used over 5 minutes, apply the specification for "Used belt".
- When reinstalling a belt which has been used over 5 minutes, adjust its deflection and tension to the intermediate value of each specification for "Used belt".
- Belt tension and deflection should be checked after 2 revolutions of engine cranking.
- When using a belt tension gauge, confirm the accuracy by using a master gauge first.

REMOVAL

1. REMOVE ENGINE UNDER COVER RH
2. REMOVE NO. 1 AIR CLEANER INLET
 - (a) Loosen the clamp, and disconnect the air cleaner inlet from the air cleaner case.

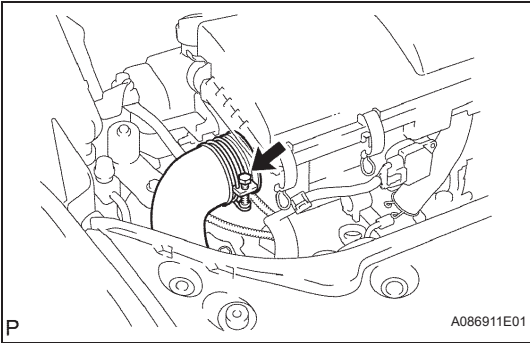

3. REMOVE DRIVE BELT
 - (a) Loosen nut A.
 - (b) Turn adjust bolt B, and then release the belt tension.
 - (c) Remove the belt.

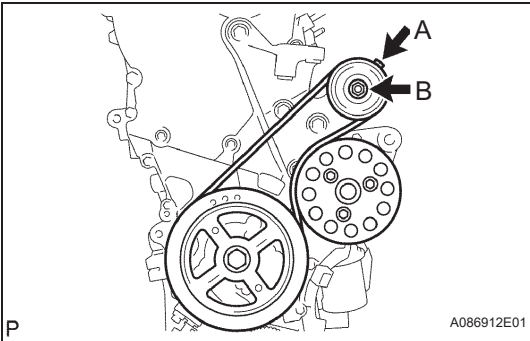

INSTALLATION

1. INSTALL DRIVE BELT

- (a) Temporarily install the belt on each pulley.

2. ADJUST DRIVE BELT TENSION

- (a) Turn adjust bolt B to adjust the belt tension.
 (b) Tighten nut A.

Torque: 40 N*m (408 kgf*cm, 30 ft.*lbf)

3. CHECK DRIVE BELT TENSION (See page [EM-5](#))

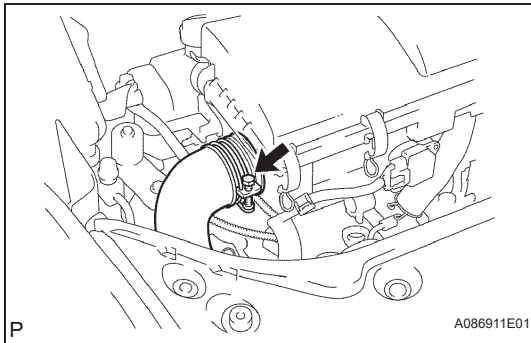
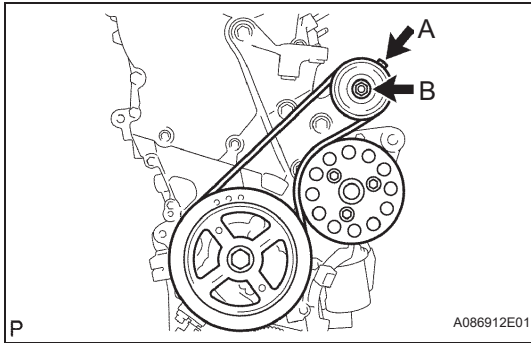

4. CONNECT NO. 1 AIR CLEANER INLET

- (a) Connect the air cleaner inlet to the air cleaner case and tighten the clamp.

Torque: 3.0 N*m (31 kgf*cm, 27 in.*lbf)

5. INSTALL ENGINE UNDER COVER RH