

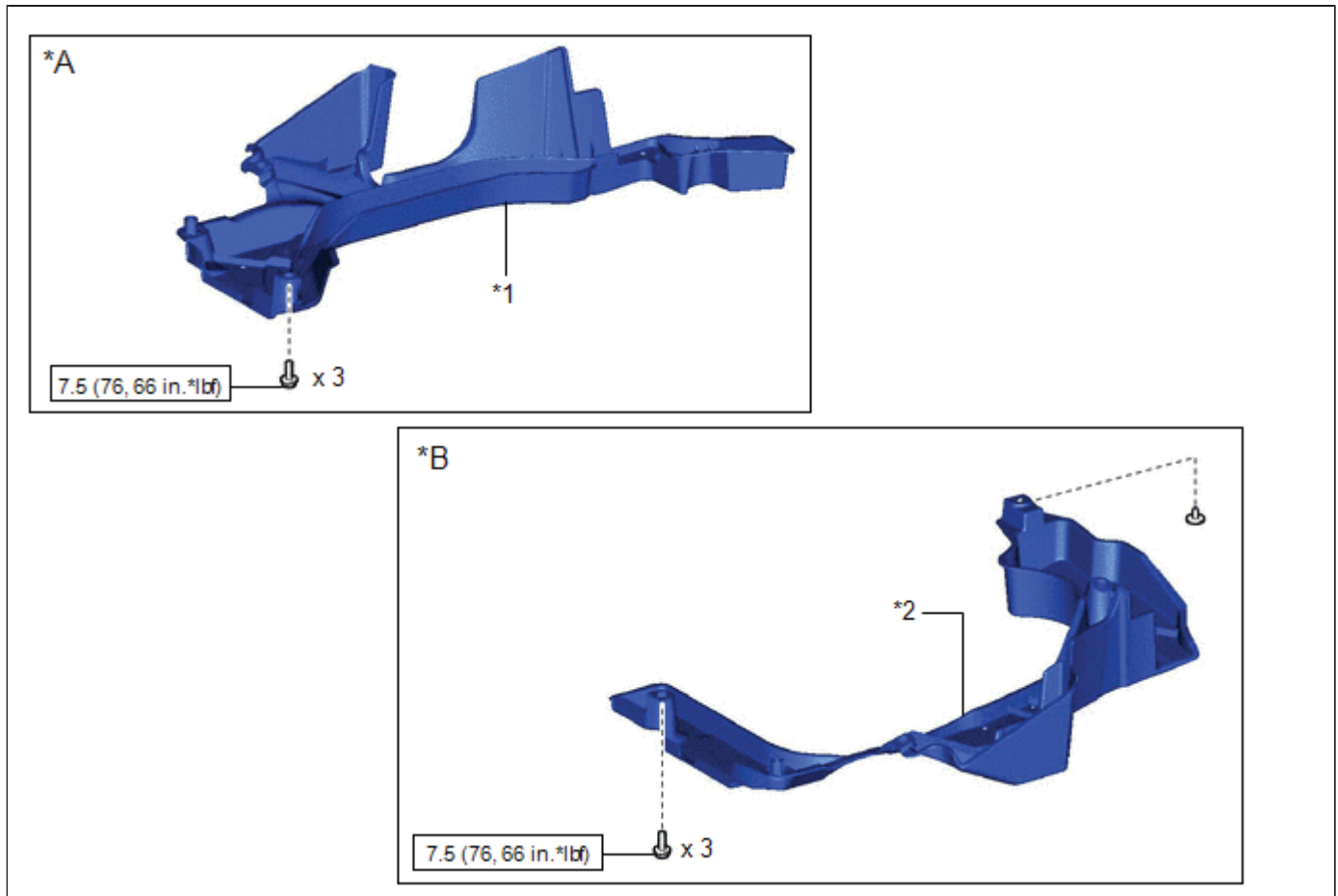

Last Modified: 01-14-2019	6.8:8.0.48	Doc ID: RM100000000RMKY
Model Year Start: 2016	Model: Prius	Prod Date Range: [11/2015 - 12/2018]
Title: REAR SUSPENSION: REAR COIL SPRING: COMPONENTS; 2016 - 2018 MY Prius [11/2015 - 12/2018]		

COMPONENTS

ILLUSTRATION



*A	for RH Side	*B	for LH Side
*1	NO. 1 FLOOR UNDER COVER ASSEMBLY	*2	REAR FLOOR SIDE MEMBER COVER LH
	N*m (kgf*cm, ft.*lbf): Specified torque	-	-

ILLUSTRATION

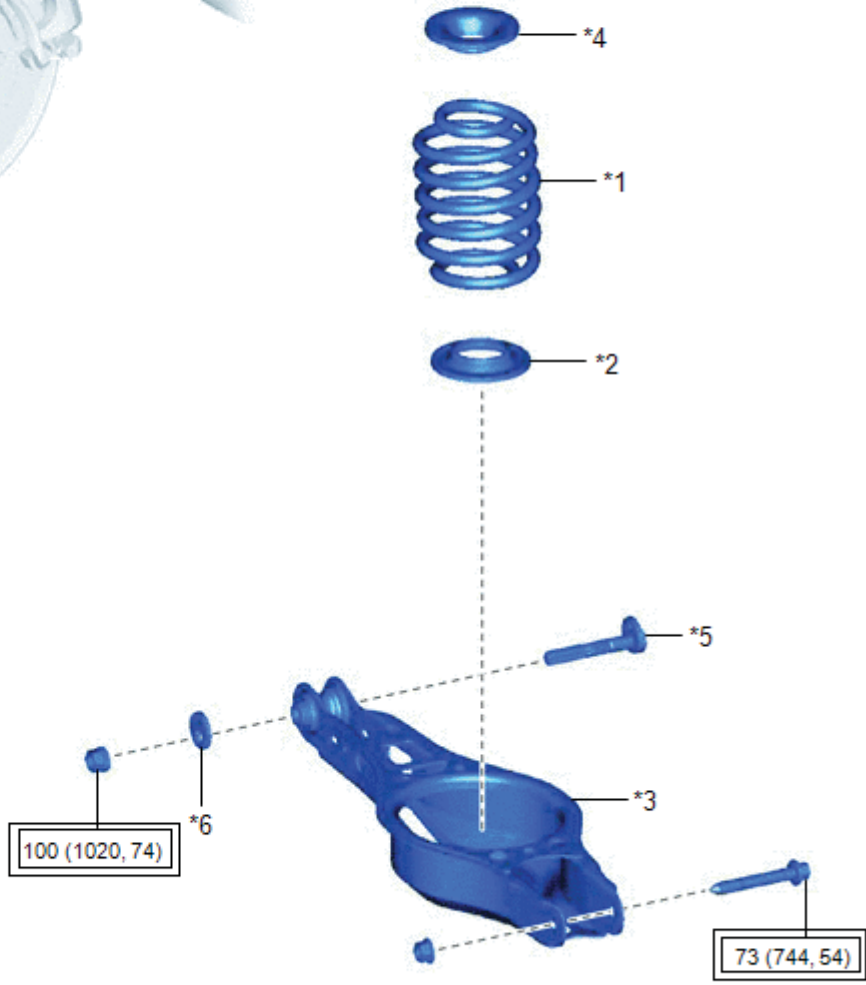
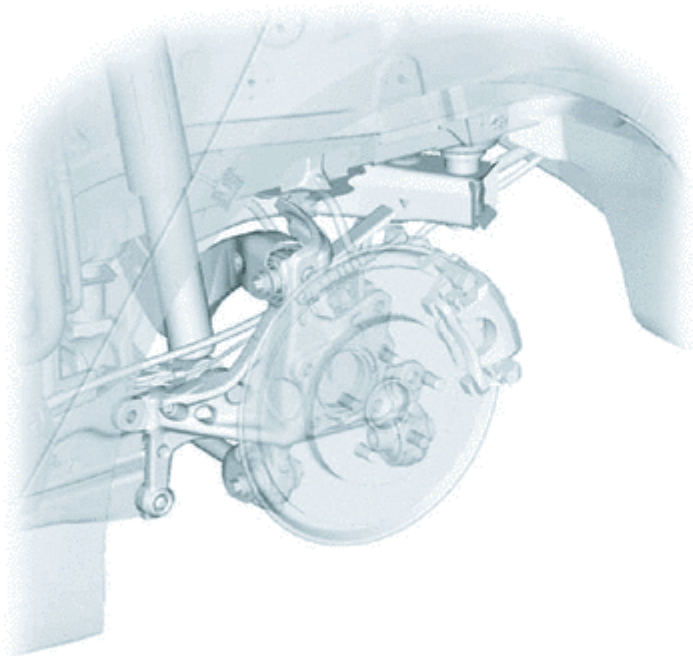

H

*1	REAR COIL SPRING	*2	REAR LOWER COIL SPRING INSULATOR
*3	REAR NO. 2 SUSPENSION ARM ASSEMBLY	*4	REAR UPPER COIL SPRING INSULATOR
*5	REAR SUSPENSION TOE ADJUST CAM SUB-ASSEMBLY	*6	NO. 2 CAMBER ADJUST CAM
	Tightening torque for "Major areas involving basic vehicle performance"		



such as moving/turning/stopping" :
N*m (kgf*cm, ft.*lbf)

-

-

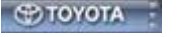

Last Modified: 01-14-2019	6.8:8.0.48	Doc ID: RM100000000RMKX
Model Year Start: 2016	Model: Prius	Prod Date Range: [11/2015 - 12/2018]
Title: REAR SUSPENSION: REAR COIL SPRING: INSTALLATION; 2016 - 2018 MY Prius [11/2015 - 12/2018]		

INSTALLATION

CAUTION / NOTICE / HINT

HINT:

- Use the same procedure for the RH side and LH side.
- The following procedure is for the LH side.

PROCEDURE

1. INSTALL REAR UPPER COIL SPRING INSULATOR

- (a) Install the rear upper coil spring insulator to the vehicle.

2. INSTALL REAR LOWER COIL SPRING INSULATOR

- (a) Install the rear lower coil spring insulator to the rear No. 2 suspension arm assembly.

3. INSTALL REAR COIL SPRING

- (a) Set the rear coil spring to the rear No. 2 suspension arm assembly.

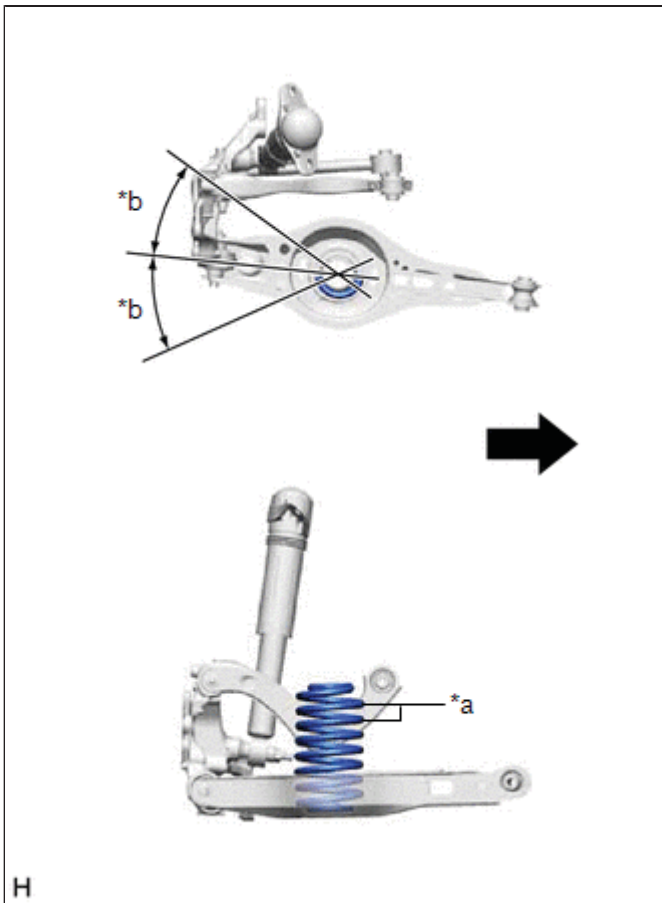

H

*a	Identification Mark
*b	30° or less



Inner Side of the Vehicle

NOTICE:

- Set the rear coil spring so that its lower end is within the range shown in the illustration.
- Set the rear coil spring so that the identification mark is positioned as shown in the illustration.

(b) Using a jack and wooden block, slowly jack up the rear No. 2 suspension arm assembly and then install the rear No. 2 suspension arm assembly to the rear axle carrier sub-assembly with the bolt and nut.

CAUTION:

Do not jack up the rear No. 2 suspension arm assembly too high as the vehicle may fall.

NOTICE:

- Because the nut has its own stopper, do not turn the nut. Tighten the bolt with the nut secured.
- When jacking up the rear No. 2 suspension arm assembly, be sure to jack it up slowly.
- Make sure to perform this operation with the vehicle kept as low as possible.
- Insert the bolt with the threaded end facing the front of the vehicle.

4. STABILIZE SUSPENSION

Click here [INFO](#)

5. INSTALL REAR NO. 2 SUSPENSION ARM ASSEMBLY

(a) Install the rear No. 2 suspension arm assembly (rear axle carrier sub-assembly side) with the bolt.

Torque:

73 N·m { 744 kgf·cm, 54 ft·lbf }

NOTICE:

Because the nut has its own stopper, do not turn the nut. Tighten the bolt with the nut secured.

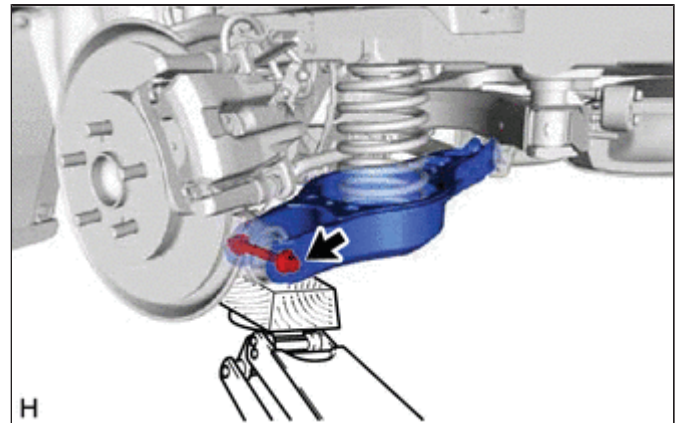

6. INSTALL REAR FLOOR SIDE MEMBER COVER LH (for LH Side)

Click here [INFO](#)

7. INSTALL NO. 1 FLOOR UNDER COVER ASSEMBLY (for RH Side)

Click here [INFO](#)

8. INSTALL REAR WHEEL

Click here [INFO](#)

9. INSTALL REAR NO. 2 SUSPENSION ARM ASSEMBLY

(a) Install the rear No. 2 suspension arm assembly (rear suspension member sub-assembly side) with the nut.

Click here [INFO](#)

10. INSPECT AND ADJUST REAR WHEEL ALIGNMENT

Click here [INFO](#)

11. PERFORM INITIALIZATION

Intelligent clearance sonar system	INFO
Simple advanced parking guidance system	

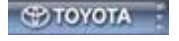

Last Modified: 01-14-2019	6.8:8.0.48	Doc ID: RM100000000RMKZ
Model Year Start: 2016	Model: Prius	Prod Date Range: [11/2015 - 12/2018]
Title: REAR SUSPENSION: REAR COIL SPRING: REMOVAL; 2016 - 2018 MY Prius [11/2015 - 12/2018]		

REMOVAL

CAUTION / NOTICE / HINT

The necessary procedures (adjustment, calibration, initialization, or registration) that must be performed after parts are removed and installed, or replaced during rear coil spring removal/installation are shown below.

Necessary Procedures After Parts Removed/Installed/Replaced

REPLACED PART OR PERFORMED PROCEDURE	NECESSARY PROCEDURE	EFFECT/INOPERATIVE FUNCTION WHEN NECESSARY PROCEDURE NOT PERFORMED	LINK
Rear wheel alignment adjustment	<ol style="list-style-type: none"> 1. Clear zero point calibration data. 2. Perform yaw rate and acceleration sensor zero point calibration. 	<ul style="list-style-type: none"> • DTCs are stored • ABS warning light illuminates • Brake warning light/yellow (minor malfunction) illuminates • Slip indicator light illuminates • VSC disabled or malfunctions 	INFO
Suspension, tires, etc. (The vehicle height changes because of suspension or tire replacement)	<ul style="list-style-type: none"> • Ultrasonic sensor detection angle • Ultrasonic sensor detection angle registration 	<ul style="list-style-type: none"> • Intelligent clearance sonar system • Simple advanced parking guidance system 	INFO

HINT:

- Use the same procedure for the RH side and LH side.
- The following procedure is for the LH side.

PROCEDURE

1. REMOVE REAR WHEEL

Click here [INFO](#)

2. REMOVE REAR FLOOR SIDE MEMBER COVER LH (for LH Side)

Click here [INFO](#)

3. REMOVE NO. 1 FLOOR UNDER COVER ASSEMBLY (for RH Side)

Click here [INFO](#)

4. REMOVE REAR COIL SPRING

- (a) Place matchmarks on the No. 2 camber adjust cam, rear suspension toe adjust cam sub-assembly and rear suspension member sub-assembly.

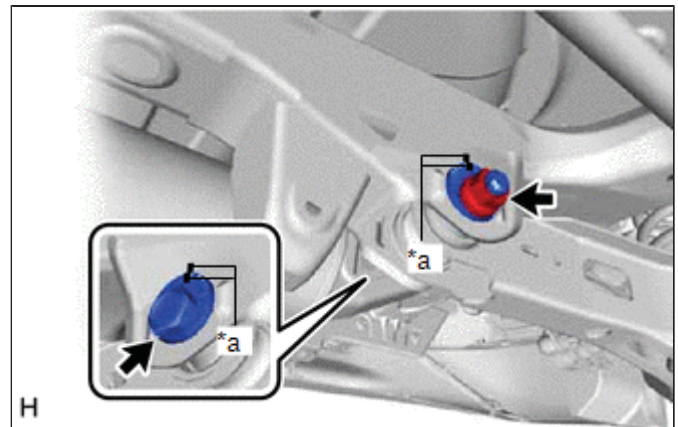

*a	Matchmark
----	-----------

- (b) Loosen the nut (rear suspension member sub-assembly side) of the rear No. 2 suspension arm assembly.

NOTICE:

Hold the rear suspension toe adjust cam sub-assembly while rotating the nut.

- (c) Using a jack and a wooden block, support the rear No. 2 suspension arm assembly.

NOTICE:

- When jacking up the rear No. 2 suspension arm assembly, be sure to jack it up slowly.
- Make sure to perform this operation with the vehicle kept as low as possible.

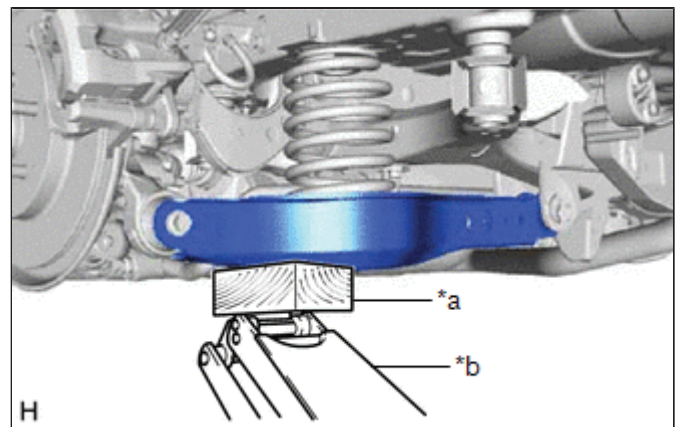

*a	Wooden Block
*b	Jack

- (d) Remove the bolt and nut, and separate the rear No. 2 suspension arm assembly from the rear axle carrier sub-assembly.

NOTICE:

Because the nut has its own stopper, do not turn the nut. Loosen the bolt with the nut secured.

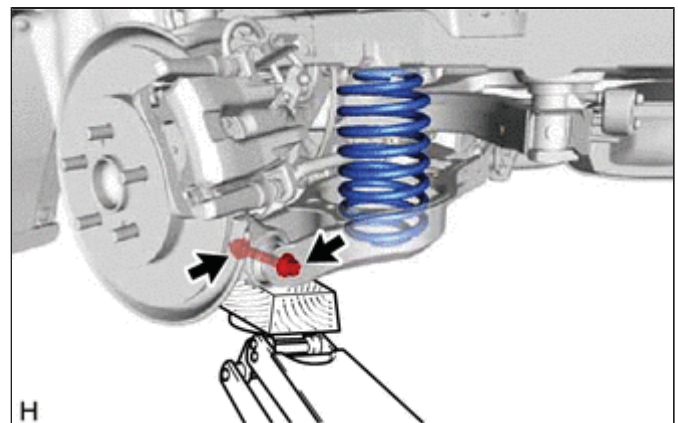

(e) Slowly lower the rear No. 2 suspension arm assembly, and then remove the rear coil spring.

5. REMOVE REAR UPPER COIL SPRING INSULATOR

(a) Remove the rear upper coil spring insulator from the vehicle.

6. REMOVE REAR LOWER COIL SPRING INSULATOR

(a) Remove the rear lower coil spring insulator from the rear No. 2 suspension arm assembly.

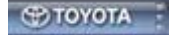

Last Modified: 01-14-2019	6.8:8.0.48	Doc ID: RM10000000RML4
Model Year Start: 2016	Model: Prius	Prod Date Range: [11/2015 - 12/2018]
Title: REAR SUSPENSION: REAR LOWER ARM: COMPONENTS; 2016 - 2018 MY Prius [11/2015 - 12/2018]		

COMPONENTS

ILLUSTRATION

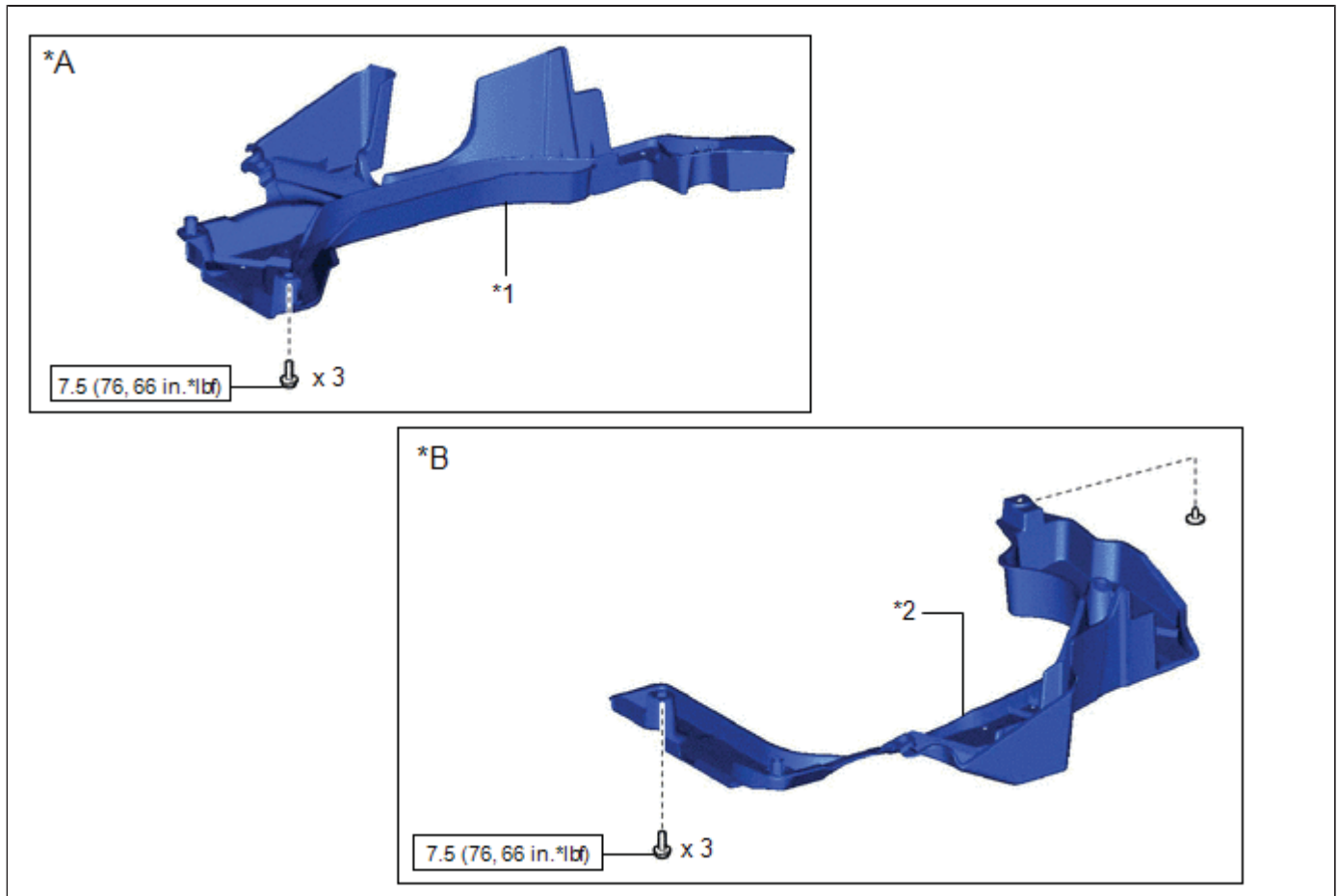

*A	for RH Side	*B	for LH Side
*1	NO. 1 FLOOR UNDER COVER ASSEMBLY	*2	REAR FLOOR SIDE MEMBER COVER LH
	N*m (kgf*cm, ft.*lbf): Specified torque	-	-

ILLUSTRATION

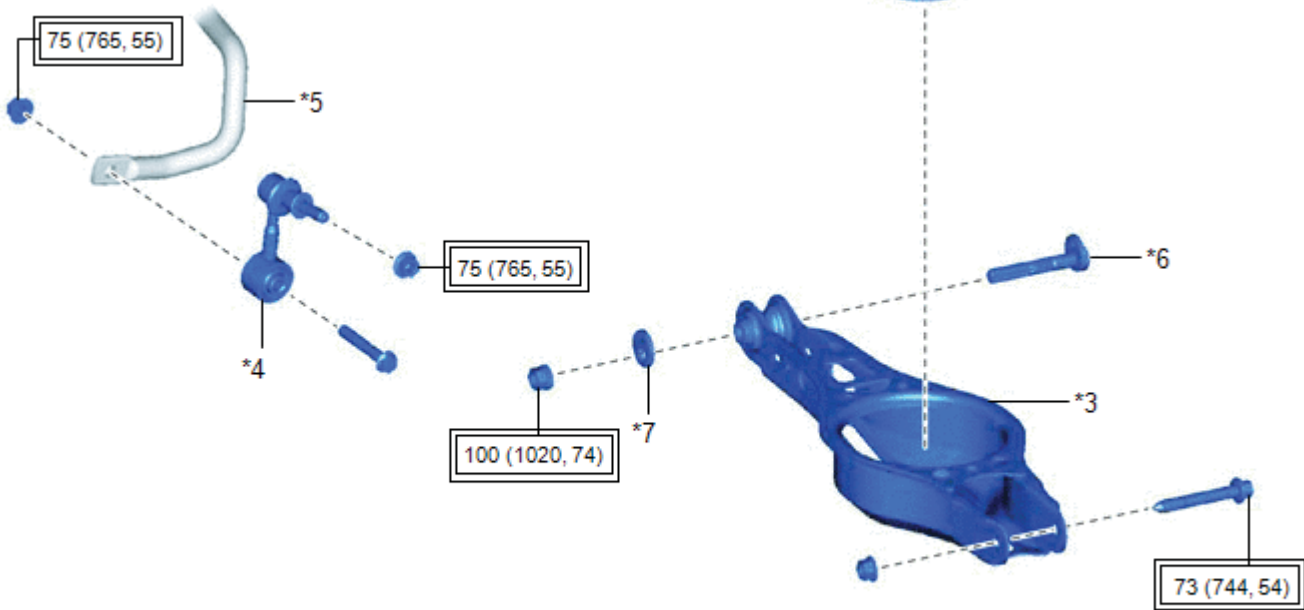
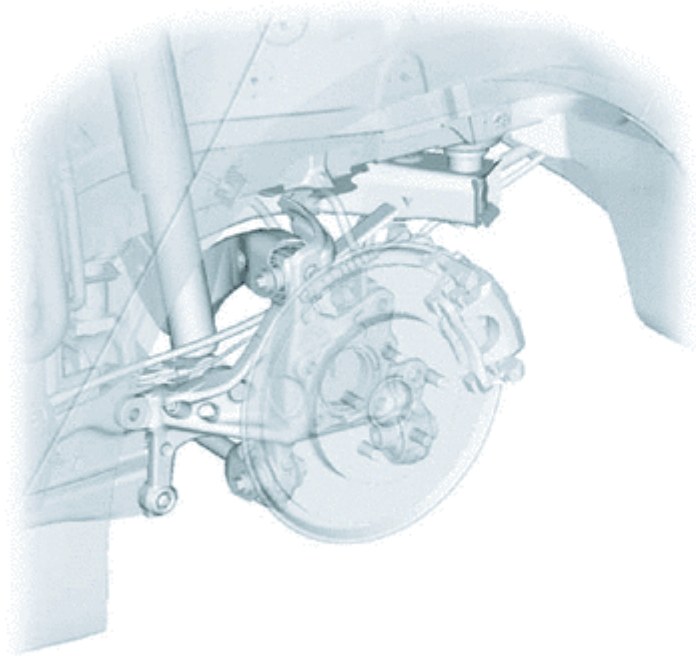

H

*1	REAR COIL SPRING	*2	REAR LOWER COIL SPRING INSULATOR
*3	REAR NO. 2 SUSPENSION ARM ASSEMBLY	*4	REAR STABILIZER LINK ASSEMBLY
*5	REAR STABILIZER BAR	*6	REAR SUSPENSION TOE ADJUST CAM SUB-ASSEMBLY
*7	NO. 2 CAMBER ADJUST CAM	-	-



Tightening torque for "Major areas involving basic vehicle performance such as moving/turning/stopping" :
N*m (kgf*cm, ft.*lbf)

-

-

ILLUSTRATION

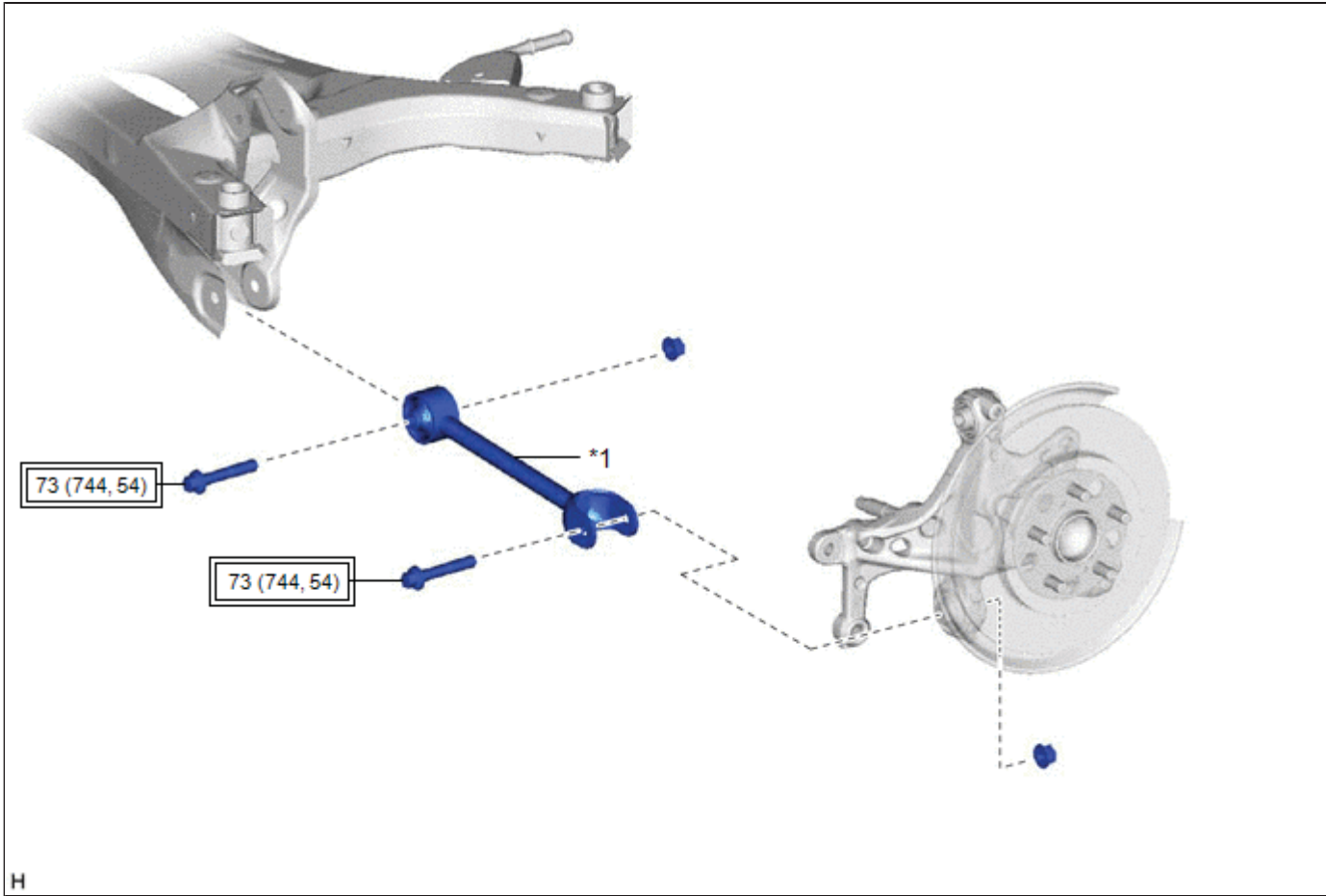

*1	REAR NO. 1 SUSPENSION ARM ASSEMBLY	-	-
	Tightening torque for "Major areas involving basic vehicle performance such as moving/turning/stopping" : N*m (kgf*cm, ft.*lbf)	-	-

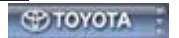

Last Modified: 01-14-2019	6.8:8.0.48	Doc ID: RM100000000RML3
Model Year Start: 2016	Model: Prius	Prod Date Range: [11/2015 - 12/2018]
Title: REAR SUSPENSION: REAR LOWER ARM: INSTALLATION; 2016 - 2018 MY Prius [11/2015 - 12/2018]		

INSTALLATION

CAUTION / NOTICE / HINT

HINT:

- Use the same procedure for the RH side and LH side.
- The following procedure is for the LH side.

PROCEDURE

1. TEMPORARILY INSTALL REAR NO. 1 SUSPENSION ARM ASSEMBLY

- (a) Temporarily install the rear No. 1 suspension arm assembly to the rear axle carrier sub-assembly and rear suspension member sub-assembly with the 2 bolts and 2 nuts.

NOTICE:

- Because the nut has its own stopper, do not turn the nut. Tighten the bolt with the nut secured.
- Insert the bolt with the threaded end facing the rear of the vehicle.

2. TEMPORARILY INSTALL REAR NO. 2 SUSPENSION ARM ASSEMBLY

- (a) Temporarily install the rear No. 2 suspension arm assembly to the rear suspension member sub-assembly with the No. 2 camber adjust cam, rear suspension toe adjust cam sub-assembly and nut.

NOTICE:

- Insert the rear suspension toe adjust cam sub-assembly from the rear of the vehicle.
- When tightening the nut, keep the rear suspension toe adjust cam sub-assembly from rotating.

3. INSTALL REAR LOWER COIL SPRING INSULATOR

Click here [INFO](#)

4. INSTALL REAR COIL SPRING

Click here [INFO](#)

5. STABILIZE SUSPENSION

Click here [INFO](#)

6. INSTALL REAR STABILIZER LINK ASSEMBLY

Click here [INFO](#)

7. INSTALL REAR NO. 1 SUSPENSION ARM ASSEMBLY

- (a) Install the rear No. 1 suspension arm assembly with the 2 bolts.

Torque:

73 N·m { 744 kgf·cm, 54 ft·lbf }

NOTICE:

Because the nut has its own stopper, do not turn the nut.
Tighten the bolt with the nut secured.

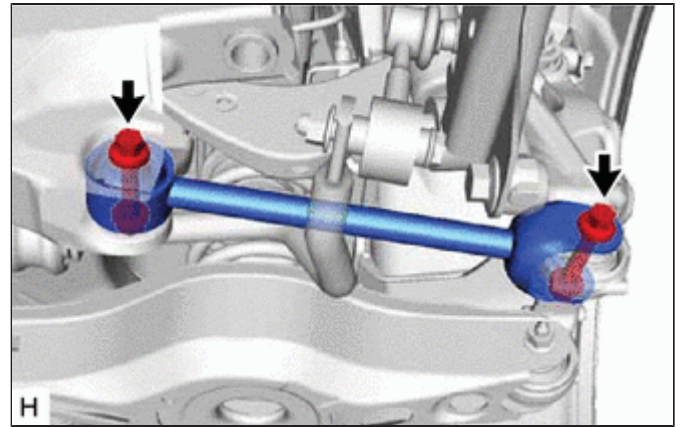

8. INSTALL REAR NO. 2 SUSPENSION ARM ASSEMBLY

- (a) Install the rear No. 2 suspension arm assembly (rear axle carrier sub-assembly side) with the bolt.

Torque:

73 N·m { 744 kgf·cm, 54 ft·lbf }

NOTICE:

Because the nut has its own stopper, do not turn the nut.
Tighten the bolt with the nut secured.

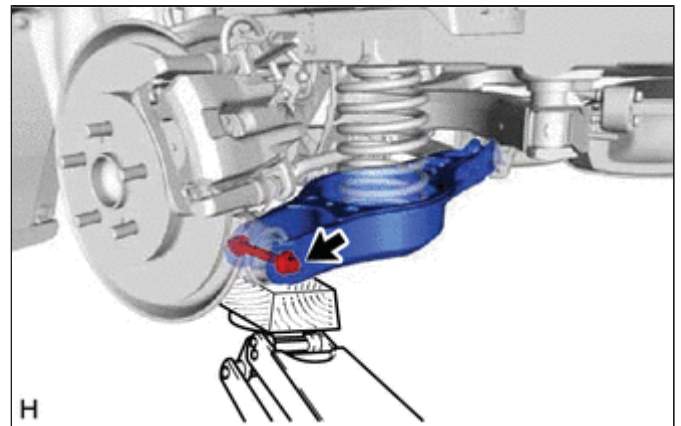

9. INSTALL REAR FLOOR SIDE MEMBER COVER LH (for LH Side)

Click here [INFO](#)

10. INSTALL NO. 1 FLOOR UNDER COVER ASSEMBLY (for RH Side)

Click here [INFO](#)

11. INSTALL REAR WHEEL

Click here [INFO](#)

12. INSTALL REAR NO. 2 SUSPENSION ARM ASSEMBLY

- (a) Lower the vehicle to the ground.
- (b) Bounce the vehicle up and down at the corners to stabilize the rear suspension.

(c) Align the matchmarks on the No. 2 camber adjust cam,

rear suspension toe adjust cam sub-assembly and rear suspension member sub-assembly.

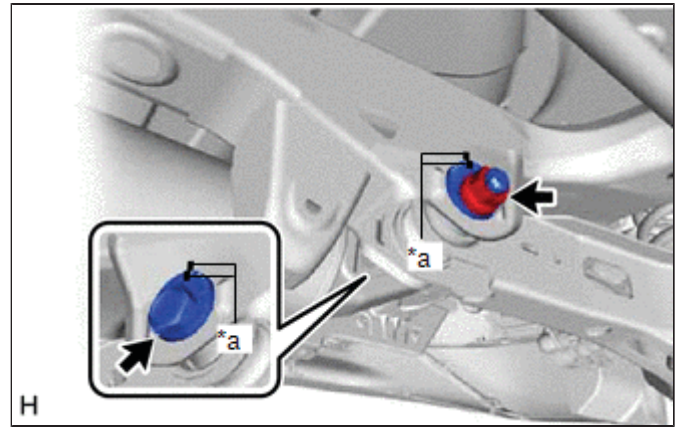

*a	Matchmark
----	-----------

(d) Fully tighten the nut.

Torque:

100 N·m { 1020 kgf·cm, 74 ft·lbf }

NOTICE:

- Hold the rear suspension toe adjust cam sub-assembly while rotating the nut.
- Make sure that the vehicle is unloaded when fully tightening the nut.

13. INSPECT AND ADJUST REAR WHEEL ALIGNMENT

Click here [INFO](#)

14. PERFORM INITIALIZATION

Intelligent clearance sonar system	INFO
Simple advanced parking guidance system	

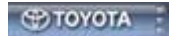

Last Modified: 01-14-2019	6.8:8.0.48	Doc ID: RM100000000RML5
Model Year Start: 2016	Model: Prius	Prod Date Range: [11/2015 - 12/2018]
Title: REAR SUSPENSION: REAR LOWER ARM: REMOVAL; 2016 - 2018 MY Prius [11/2015 - 12/2018]		

REMOVAL

CAUTION / NOTICE / HINT

The necessary procedures (adjustment, calibration, initialization, or registration) that must be performed after parts are removed and installed, or replaced during rear suspension arm assembly removal/installation are shown below.

Necessary Procedures After Parts Removed/Installed/Replaced

REPLACED PART OR PERFORMED PROCEDURE	NECESSARY PROCEDURE	EFFECT/INOPERATIVE FUNCTION WHEN NECESSARY PROCEDURE NOT PERFORMED	LINK
Rear wheel alignment adjustment	<ol style="list-style-type: none"> 1. Clear zero point calibration data. 2. Perform yaw rate and acceleration sensor zero point calibration. 	<ul style="list-style-type: none"> • DTCs are stored • ABS warning light illuminates • Brake warning light/yellow (minor malfunction) illuminates • Slip indicator light illuminates • VSC disabled or malfunctions 	INFO
Suspension, tires, etc. (The vehicle height changes because of suspension or tire replacement)	<ul style="list-style-type: none"> • Ultrasonic sensor detection angle • Ultrasonic sensor detection angle registration 	<ul style="list-style-type: none"> • Intelligent clearance sonar system • Simple advanced parking guidance system 	INFO

HINT:

- Use the same procedure for the RH side and LH side.
- The following procedure is for the LH side.

PROCEDURE

1. REMOVE REAR WHEEL

Click here [INFO](#)

2. REMOVE REAR FLOOR SIDE MEMBER COVER LH (for LH Side)

Click here [INFO](#)

3. REMOVE NO. 1 FLOOR UNDER COVER ASSEMBLY (for RH Side)

Click here [INFO](#)

4. REMOVE REAR STABILIZER LINK ASSEMBLY

Click here [INFO](#)

5. REMOVE REAR COIL SPRING

Click here [INFO](#)

6. REMOVE REAR LOWER COIL SPRING INSULATOR

Click here [INFO](#)

7. REMOVE REAR NO. 2 SUSPENSION ARM ASSEMBLY

- (a) Remove the nut, No. 2 camber adjust cam, rear suspension toe adjust cam sub-assembly and rear No. 2 suspension arm assembly.

NOTICE:

Hold the rear suspension toe adjust cam sub-assembly while rotating the nut.

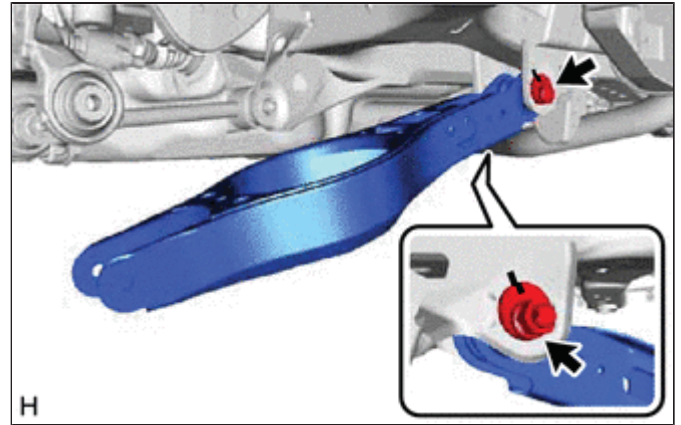

8. REMOVE REAR NO. 1 SUSPENSION ARM ASSEMBLY

- (a) Remove the 2 bolts, 2 nuts and rear No. 1 suspension arm assembly from the rear axle carrier sub-assembly and rear suspension member sub-assembly.

NOTICE:

Because the nut has its own stopper, do not turn the nut. Loosen the bolt with the nut secured.

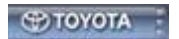
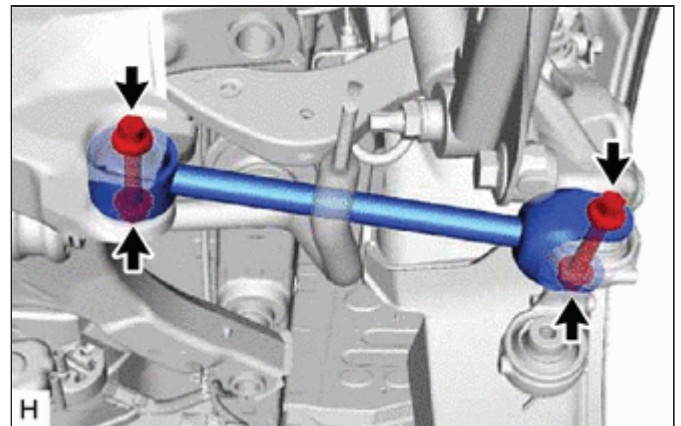

Last Modified: 01-14-2019	6.8:8.0.48	Doc ID: RM100000000RMKV
Model Year Start: 2016	Model: Prius	Prod Date Range: [11/2015 - 12/2018]
Title: REAR SUSPENSION: REAR SHOCK ABSORBER: COMPONENTS; 2016 - 2018 MY Prius [11/2015 - 12/2018]		

COMPONENTS

ILLUSTRATION

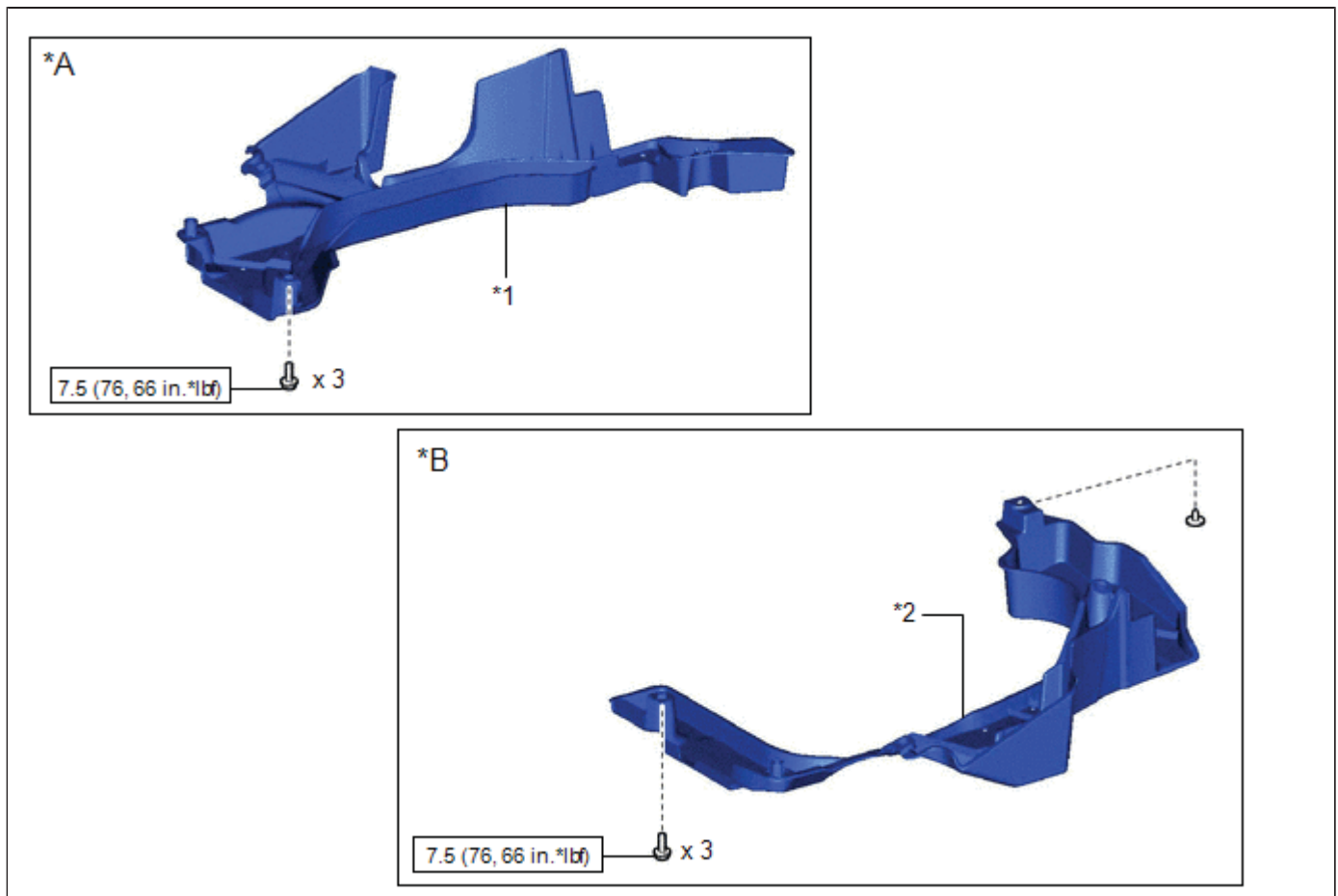

*A	for RH Side	*B	for LH Side
*1	NO. 1 FLOOR UNDER COVER ASSEMBLY	*2	REAR FLOOR SIDE MEMBER COVER LH
	N*m (kgf*cm, ft.*lbf): Specified torque	-	-

ILLUSTRATION

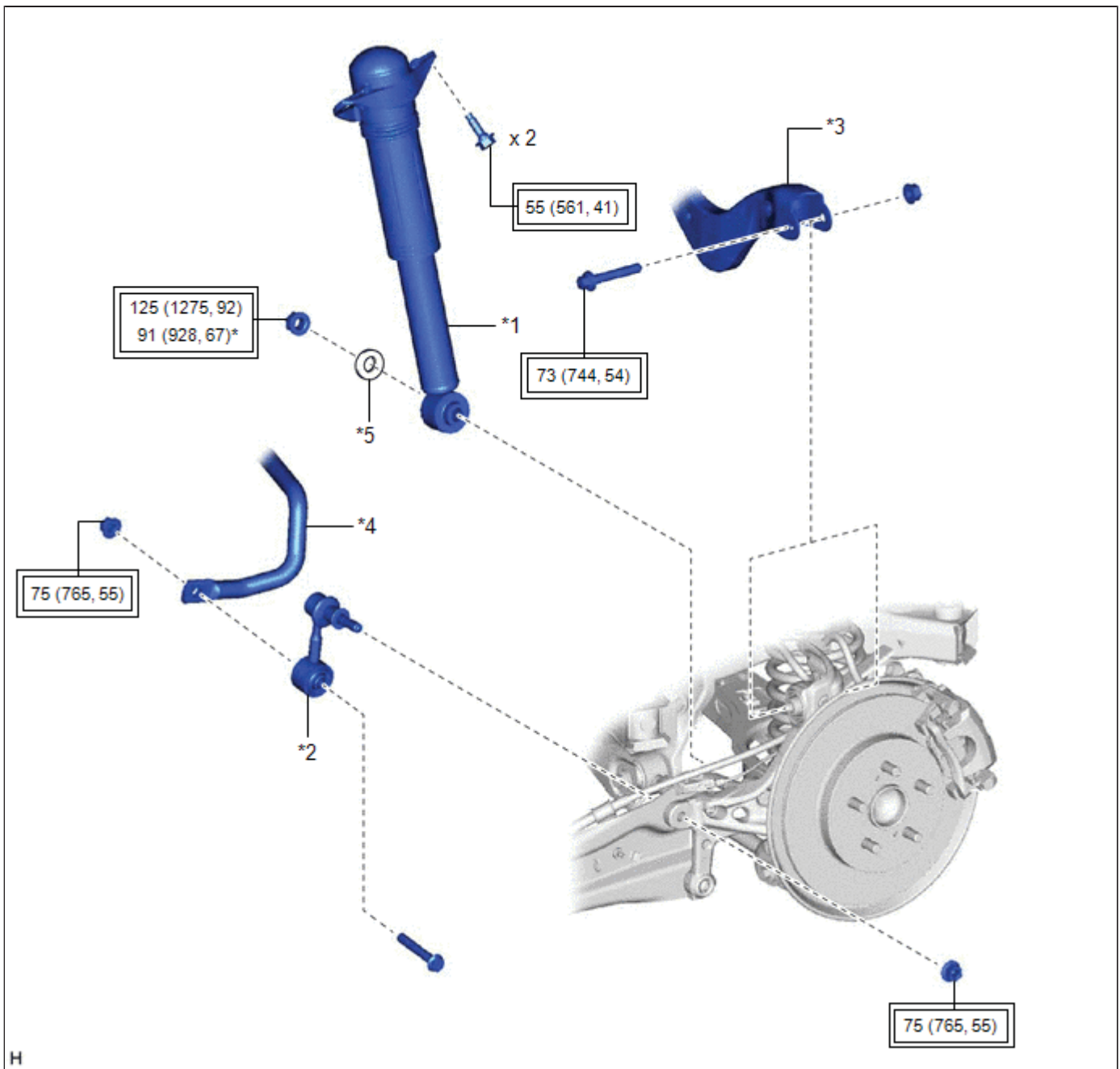

H

*1	REAR SHOCK ABSORBER ASSEMBLY	*2	REAR STABILIZER LINK ASSEMBLY
*3	REAR UPPER CONTROL ARM ASSEMBLY	*4	REAR STABILIZER BAR
*5	PLATE WASHER	-	-
	Tightening torque for "Major areas involving basic vehicle performance such as moving/turning/stopping" : N*m (kgf*cm, ft.*lbf)	*	For use with a ball joint lock nut wrench

ILLUSTRATION

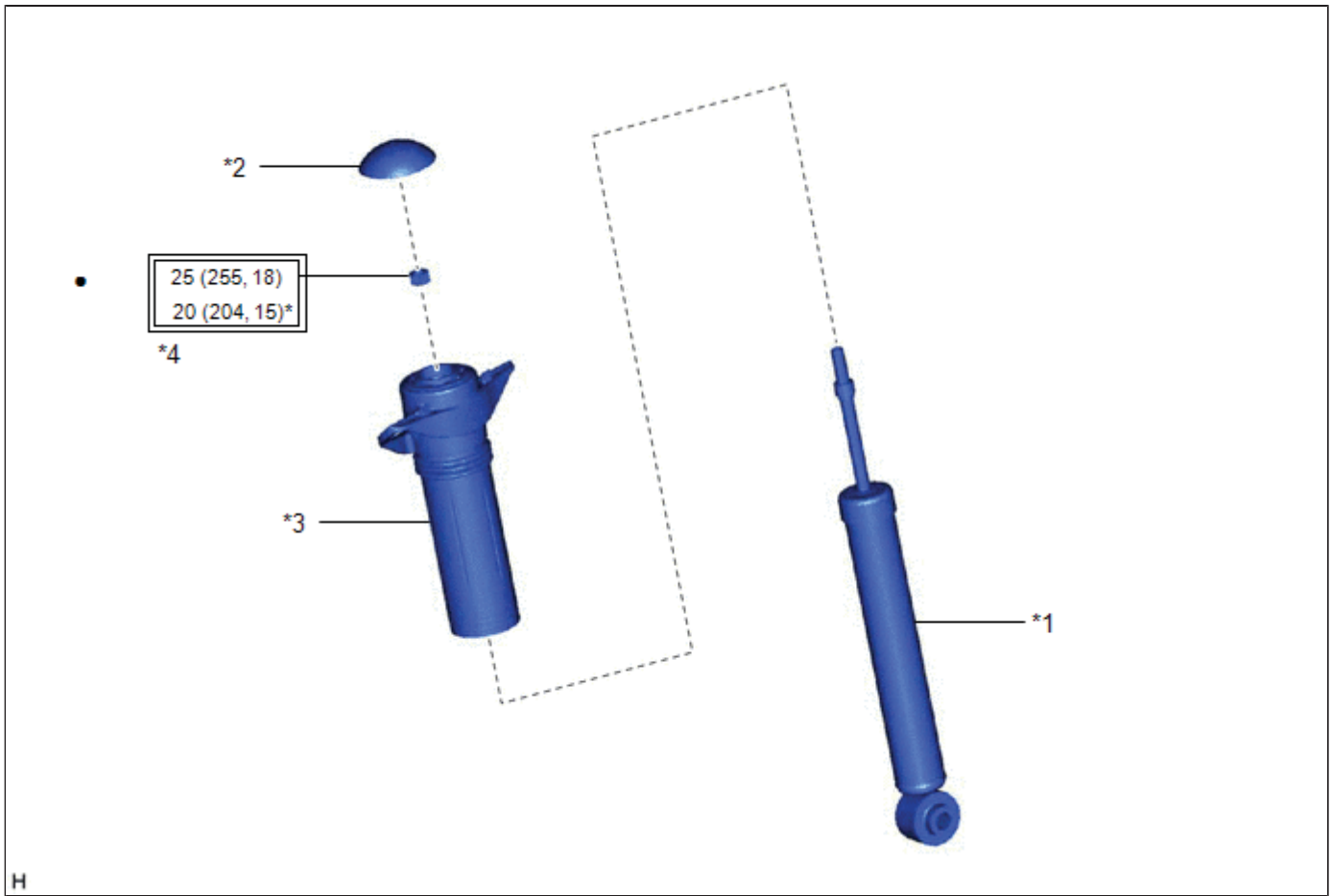

H

*1	REAR SHOCK ABSORBER ASSEMBLY	*2	REAR SHOCK ABSORBER CAP
*3	REAR SUSPENSION SUPPORT ASSEMBLY	*4	REAR SUPPORT TO REAR SHOCK ABSORBER NUT
	Tightening torque for "Major areas involving basic vehicle performance such as moving/turning/stopping" : N*m (kgf*cm, ft.*lbf)	*	For use with SST
•	Non-reusable part		Precoated part

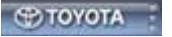

Last Modified: 01-14-2019	6.8:8.0.48	Doc ID: RM100000000RMKS
Model Year Start: 2016	Model: Prius	Prod Date Range: [11/2015 - 12/2018]
Title: REAR SUSPENSION: REAR SHOCK ABSORBER: DISPOSAL; 2016 - 2018 MY Prius [11/2015 - 12/2018]		

DISPOSAL

PROCEDURE

1. DISPOSE OF REAR SHOCK ABSORBER ASSEMBLY

- (a) Extend the piston rod and secure the rear shock absorber assembly at an angle in a vise.

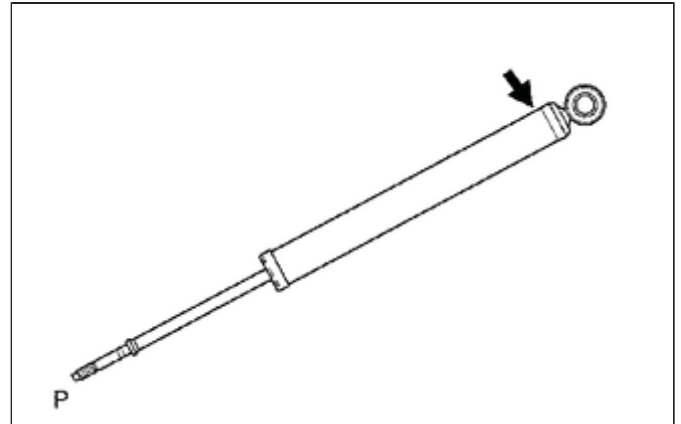

- (b) Using a hacksaw, slowly make a hole at the position indicated by the arrow in the illustration to discharge the gas inside.

CAUTION:

- Always use a cloth to prevent shards of metal flying about due to the release of pressurized gas.
- Always wear safety glasses.

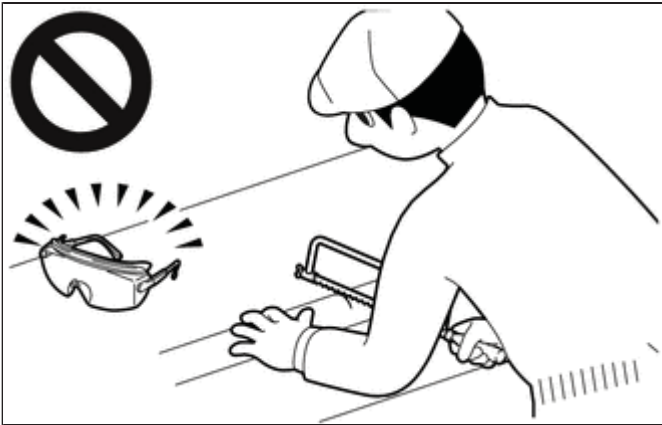

HINT:

The gas is colorless, odorless and non-poisonous.

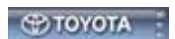

Last Modified: 01-14-2019	6.8:8.0.48	Doc ID: RM1000000000RMKU
Model Year Start: 2016	Model: Prius	Prod Date Range: [11/2015 -]
Title: REAR SUSPENSION: REAR SHOCK ABSORBER: INSPECTION; 2016 - 2019 MY Prius [11/2015 -]		

INSPECTION

PROCEDURE

1. INSPECT REAR SHOCK ABSORBER ASSEMBLY

- (a) Compress and extend the rear shock absorber assembly rod 4 or more times.

Standard:

When compressed and extended at a constant speed, the stroke of the shock absorber rod is smooth with no abnormal resistance or sounds. When extended, the shock absorber rod returns to its original position at a constant speed with no abnormal sounds.

HINT:

If there are any abnormalities, replace the rear shock absorber assembly with a new one.

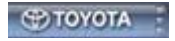

Last Modified: 01-14-2019	6.8:8.0.48	Doc ID: RM100000000RMKT
Model Year Start: 2016	Model: Prius	Prod Date Range: [11/2015 - 12/2018]
Title: REAR SUSPENSION: REAR SHOCK ABSORBER: INSTALLATION; 2016 - 2018 MY Prius [11/2015 - 12/2018]		

INSTALLATION

CAUTION / NOTICE / HINT

HINT:

- Use the same procedure for the RH side and LH side.
- The following procedure is for the LH side.

PROCEDURE

1. INSTALL REAR SUSPENSION SUPPORT ASSEMBLY

- (a) Secure the rear suspension support assembly in a vise using aluminum plates.

NOTICE:

Do not overtighten the vise.

- (b) Install the rear suspension support assembly to the rear shock absorber assembly.
(c) Apply a few drops of adhesive to the threads of a new rear support to rear shock absorber nut.

Adhesive:

Toyota Genuine Adhesive 1324, Three Bond 1324 or equivalent

- (d) Using SST and a 6 mm hexagon socket wrench, hold the rear shock absorber rod and tighten the rear support to rear shock absorber nut.

SST: 09729-97202

Torque:

Specified tightening torque :

25 N·m { 255 kgf·cm, 18 ft·lbf }

NOTICE:

Securely insert the 6 mm hexagon socket wrench into the rear shock absorber rod to prevent damage to the rear shock absorber assembly when tightening the rear support to rear shock absorber nut.

HINT:

- Calculate the torque wrench reading when changing the fulcrum length of the torque wrench.

Click here [INFO](#) [INFO](#)

- When using SST (fulcrum length of 40 mm (1.57 in.)) + torque wrench (fulcrum length of 180 mm (7.09 in.)):

20 N·m (204 kgf·cm, 15 ft·lbf)

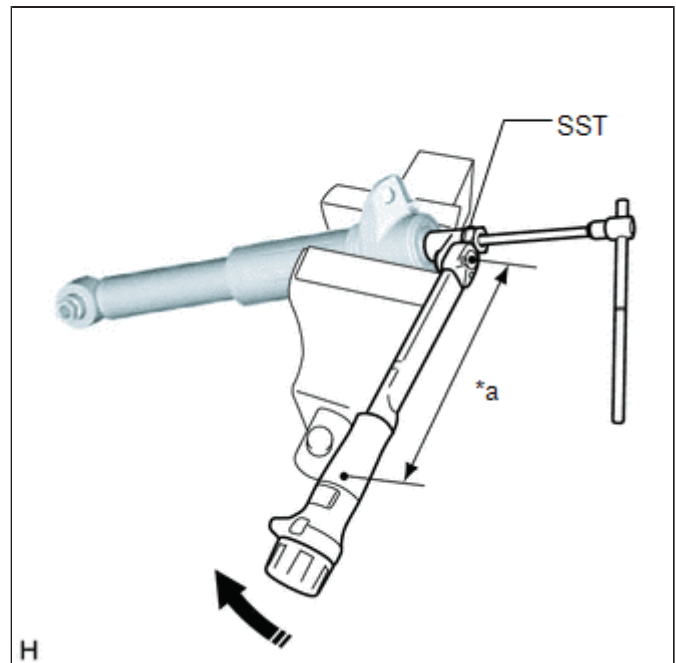

*a	Torque Wrench Fulcrum Length
----	------------------------------

2. INSTALL REAR SHOCK ABSORBER CAP

- (a) Install the rear shock absorber cap to the rear shock absorber assembly.

3. TEMPORARILY INSTALL REAR SHOCK ABSORBER ASSEMBLY

(a) Temporarily install the rear shock absorber assembly to the rear axle carrier sub-assembly with the nut and plate washer.

NOTICE:

Hold the rear axle carrier pin while rotating the nut.

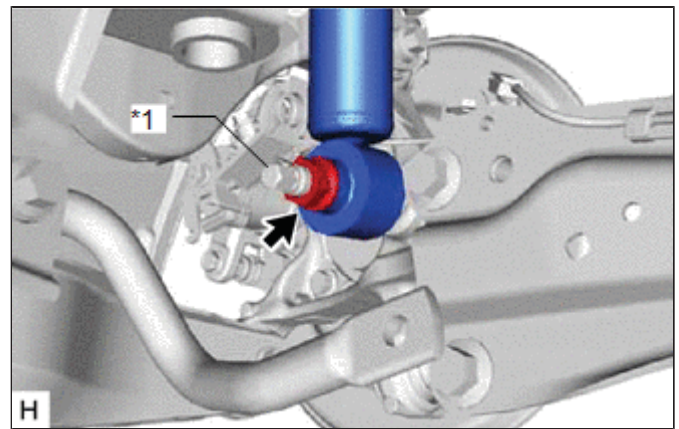

*1	Rear Axle Carrier Pin
----	-----------------------

4. STABILIZE SUSPENSION

(a) Using a jack and a wooden block, apply load to the suspension so that the rear No. 2 suspension arm assembly is positioned as shown in the illustration.

Standard Length (A):
13 mm (0.512 in.)

CAUTION:

Do not jack up the rear No. 2 suspension arm assembly too high as the vehicle may fall.

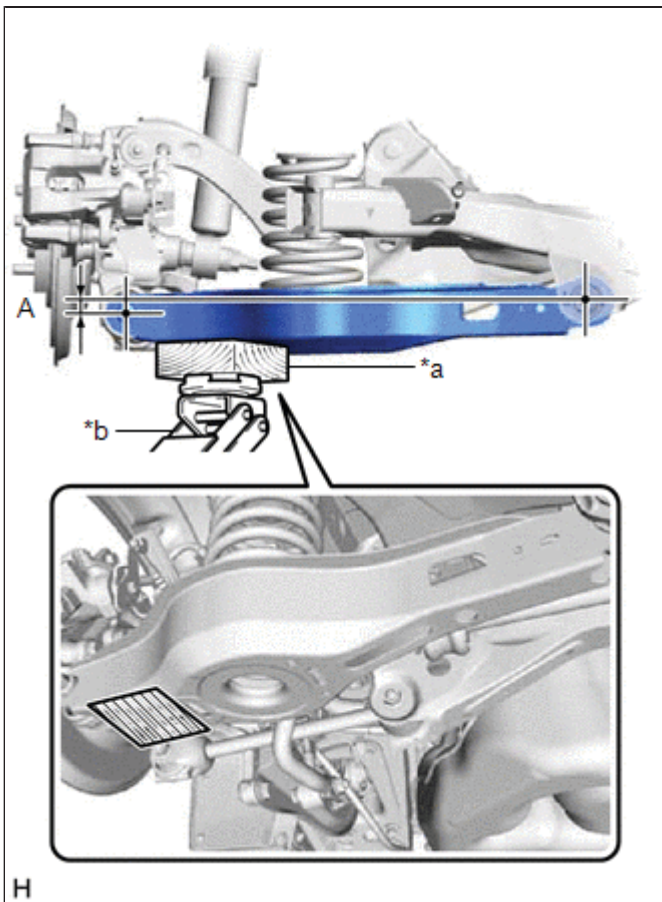

*a	Wooden Block
----	--------------

*b	Jack
	Wooden Block Placement Location

NOTICE:

- When jacking up the rear No. 2 suspension arm assembly, be sure to jack it up slowly.
- Make sure to perform this operation with the vehicle kept as low as possible.

5. TEMPORARILY INSTALL REAR UPPER CONTROL ARM ASSEMBLY

(a) Temporarily install the rear upper control arm assembly to the rear axle carrier sub-assembly with the bolt and nut.

NOTICE:

- Insert the bolt with the threaded end facing the rear of the vehicle.
- Because the nut has its own stopper, do not turn the nut. Tighten the bolt with the nut secured.

6. CONNECT REAR SHOCK ABSORBER ASSEMBLY

(a) Connect the rear shock absorber assembly to the vehicle with the 2 bolts.

Torque:

55 N·m { 561 kgf·cm, 41 ft·lbf }

NOTICE:

Temporarily tighten bolt (A) and then fully tighten the 2 bolts in the order of (B) and (A).

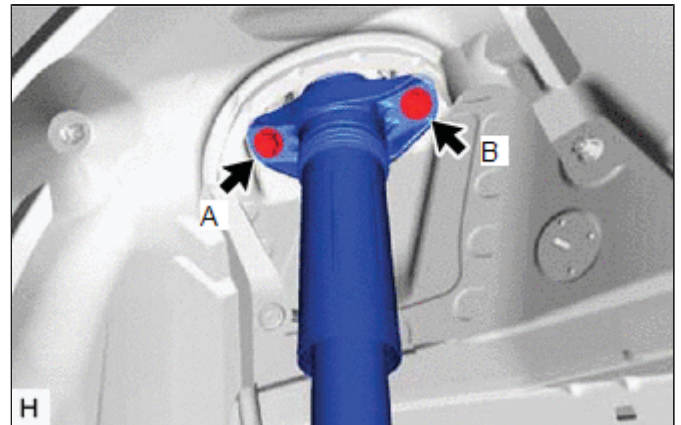

7. INSTALL REAR SHOCK ABSORBER ASSEMBLY

(a) Using a ball joint lock nut wrench fully tighten the rear shock absorber assembly with the nut.

Torque:

Specified tightening torque :

125 N·m { 1275 kgf·cm, 92 ft·lbf }

NOTICE:

Hold the rear axle carrier pin while rotating the nut.

HINT:

- Calculate the torque wrench reading when changing the fulcrum length of the torque wrench.

Click here [INFO](#) [INFO](#)

- When using a ball joint lock nut wrench (fulcrum length of 150.25 mm (5.92 in.)) + torque wrench (fulcrum length of 400 mm (1.31 ft.)):

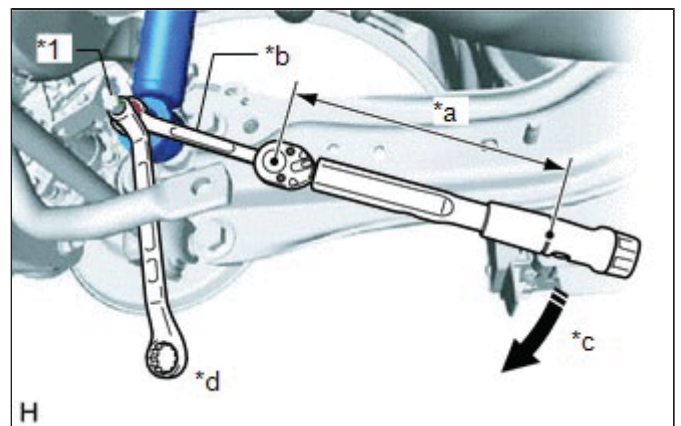

*1	Rear Axle Carrier Pin
*a	Torque Wrench Fulcrum Length
*b	Ball Joint Lock Nut Wrench

91 N*m (928 kgf*cm, 67 ft.*lbf)

*c	Turn
*d	Hold

8. INSTALL REAR UPPER CONTROL ARM ASSEMBLY

(a) Install the rear upper control arm assembly to the rear axle carrier sub-assembly with the bolt.

Torque:

73 N·m { 744 kgf·cm, 54 ft·lbf }

NOTICE:

Because the nut has its own stopper, do not turn the nut. Tighten the bolt with the nut secured.

9. INSTALL REAR STABILIZER LINK ASSEMBLY

Click here [INFO](#)

10. INSTALL REAR FLOOR SIDE MEMBER COVER LH (for LH Side)

Click here [INFO](#)

11. INSTALL NO. 1 FLOOR UNDER COVER ASSEMBLY (for RH Side)

Click here [INFO](#)

12. INSTALL REAR WHEEL

Click here [INFO](#)

13. INSPECT AND ADJUST REAR WHEEL ALIGNMENT

Click here [INFO](#)

14. PERFORM INITIALIZATION

Intelligent clearance sonar system	INFO
Simple advanced parking guidance system	

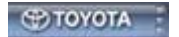

Last Modified: 01-14-2019	6.8:8.0.48	Doc ID: RM100000000RMKW
Model Year Start: 2016	Model: Prius	Prod Date Range: [11/2015 - 12/2018]
Title: REAR SUSPENSION: REAR SHOCK ABSORBER: REMOVAL; 2016 - 2018 MY Prius [11/2015 - 12/2018]		

REMOVAL

CAUTION / NOTICE / HINT

The necessary procedures (adjustment, calibration, initialization, or registration) that must be performed after parts are removed and installed, or replaced during rear shock absorber assembly removal/installation are shown below.

Necessary Procedures After Parts Removed/Installed/Replaced

REPLACED PART OR PERFORMED PROCEDURE	NECESSARY PROCEDURE	EFFECT/INOPERATIVE FUNCTION WHEN NECESSARY PROCEDURE NOT PERFORMED	LINK
Rear wheel alignment adjustment	<ol style="list-style-type: none"> 1. Clear zero point calibration data. 2. Perform yaw rate and acceleration sensor zero point calibration. 	<ul style="list-style-type: none"> • DTCs are stored • ABS warning light illuminates • Brake warning light/yellow (minor malfunction) illuminates • Slip indicator light illuminates • VSC disabled or malfunctions 	INFO
Suspension, tires, etc. (The vehicle height changes because of suspension or tire replacement)	<ul style="list-style-type: none"> • Ultrasonic sensor detection angle • Ultrasonic sensor detection angle registration 	<ul style="list-style-type: none"> • Intelligent clearance sonar system • Simple advanced parking guidance system 	INFO

HINT:

- Use the same procedure for the RH side and LH side.
- The following procedure is for the LH side.

PROCEDURE

1. REMOVE REAR WHEEL

Click here [INFO](#)

2. REMOVE REAR FLOOR SIDE MEMBER COVER LH (for LH Side)

Click here [INFO](#)

3. REMOVE NO. 1 FLOOR UNDER COVER ASSEMBLY (for RH Side)

Click here [INFO](#)

4. SEPARATE REAR SHOCK ABSORBER ASSEMBLY

- (a) Remove the 2 bolts and separate the rear shock absorber assembly from the vehicle.

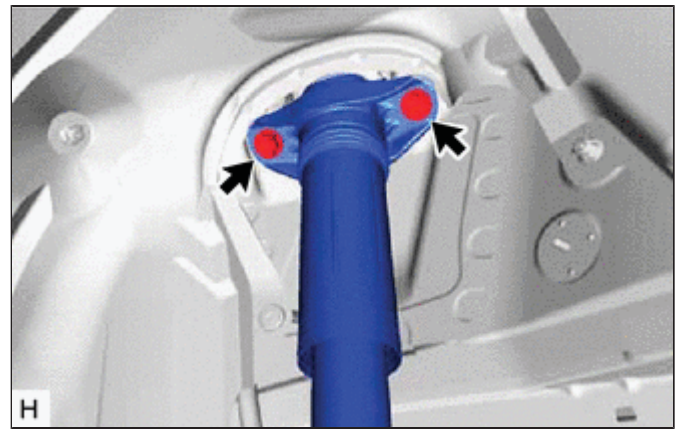

5. LOOSEN REAR SHOCK ABSORBER ASSEMBLY

- (a) Loosen the nut of the rear shock absorber assembly.

NOTICE:

Hold the rear axle carrier pin while rotating the nut.

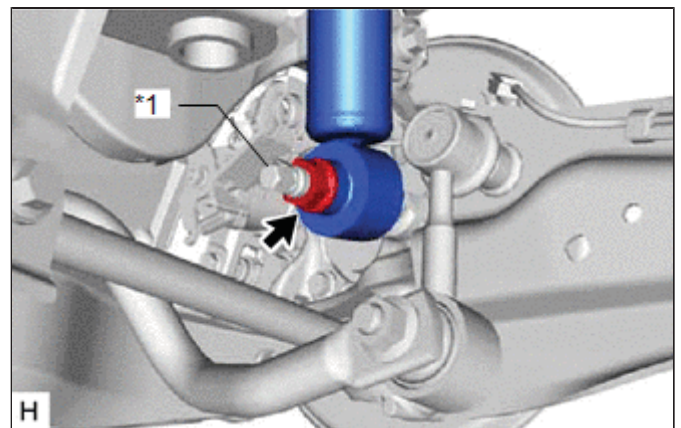

*1	Rear Axle Carrier Pin
----	-----------------------

6. REMOVE REAR STABILIZER LINK ASSEMBLY

Click here [INFO](#)

7. SEPARATE REAR UPPER CONTROL ARM ASSEMBLY

- (a) Remove the bolt and nut, and separate the rear upper control arm assembly from the rear axle carrier sub-assembly.

NOTICE:

Because the nut has its own stopper, do not turn the nut. Loosen the bolt with the nut secured.

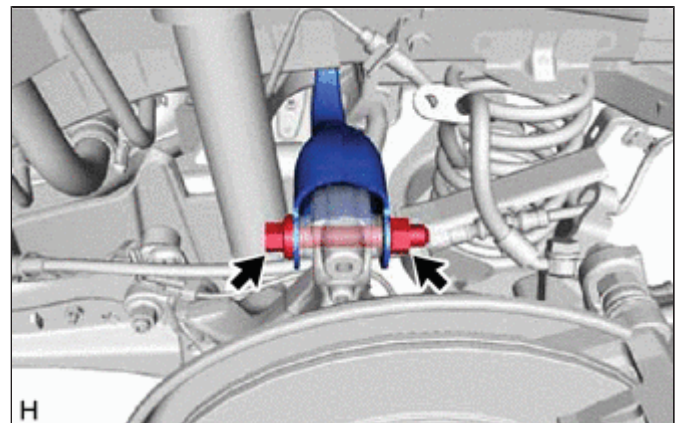

8. REMOVE REAR SHOCK ABSORBER ASSEMBLY

- (a) Remove the nut, plate washer and rear shock absorber assembly from the rear axle carrier sub-assembly.

NOTICE:

Hold the rear axle carrier pin while rotating the nut.

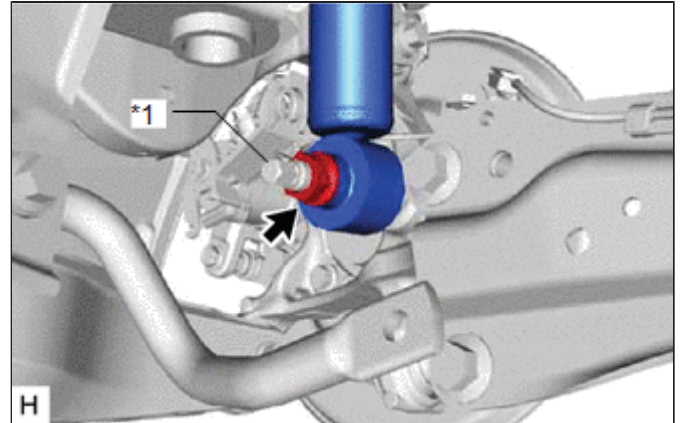

*1	Rear Axle Carrier Pin
----	-----------------------

9. REMOVE REAR SHOCK ABSORBER CAP

- (a) Using a screwdriver with its tip wrapped with protective tape, remove the rear shock absorber cap from the rear shock absorber assembly.

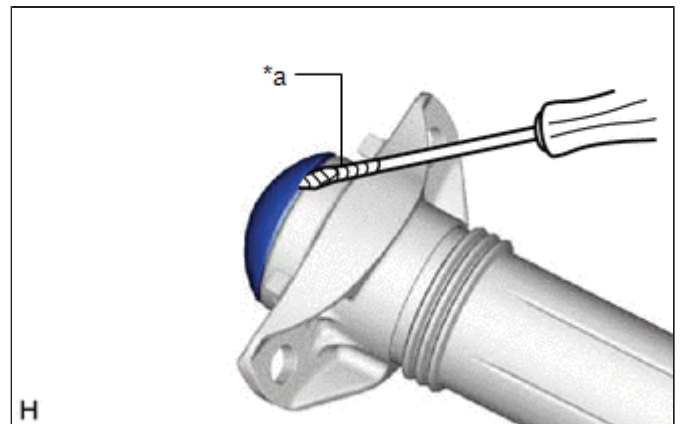

*a	Protective Tape
----	-----------------

10. REMOVE REAR SUSPENSION SUPPORT ASSEMBLY

- (a) Secure the rear shock absorber assembly in a vise using aluminum plates.

NOTICE:

Do not overtighten the vise.

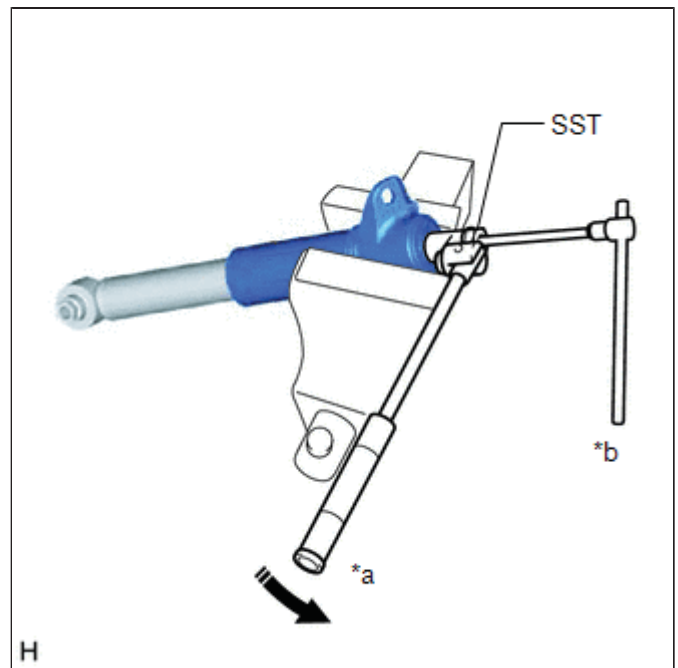

*a	Turn
*b	Hold

(b) Using SST and a 6 mm hexagon socket wrench, hold the rear shock absorber rod and remove the rear support to rear shock absorber nut.

SST: 09729-97202

(c) Remove the rear suspension support assembly from the rear shock absorber assembly.



Last Modified: 01-14-2019	6.8: 8.0.48	Doc ID: RM10000000RMLB
Model Year Start: 2016	Model: Prius	Prod Date Range: [11/2015 - 12/2018]
Title: REAR SUSPENSION: REAR STABILIZER BAR: COMPONENTS; 2016 - 2018 MY Prius [11/2015 - 12/2018]		

COMPONENTS

ILLUSTRATION

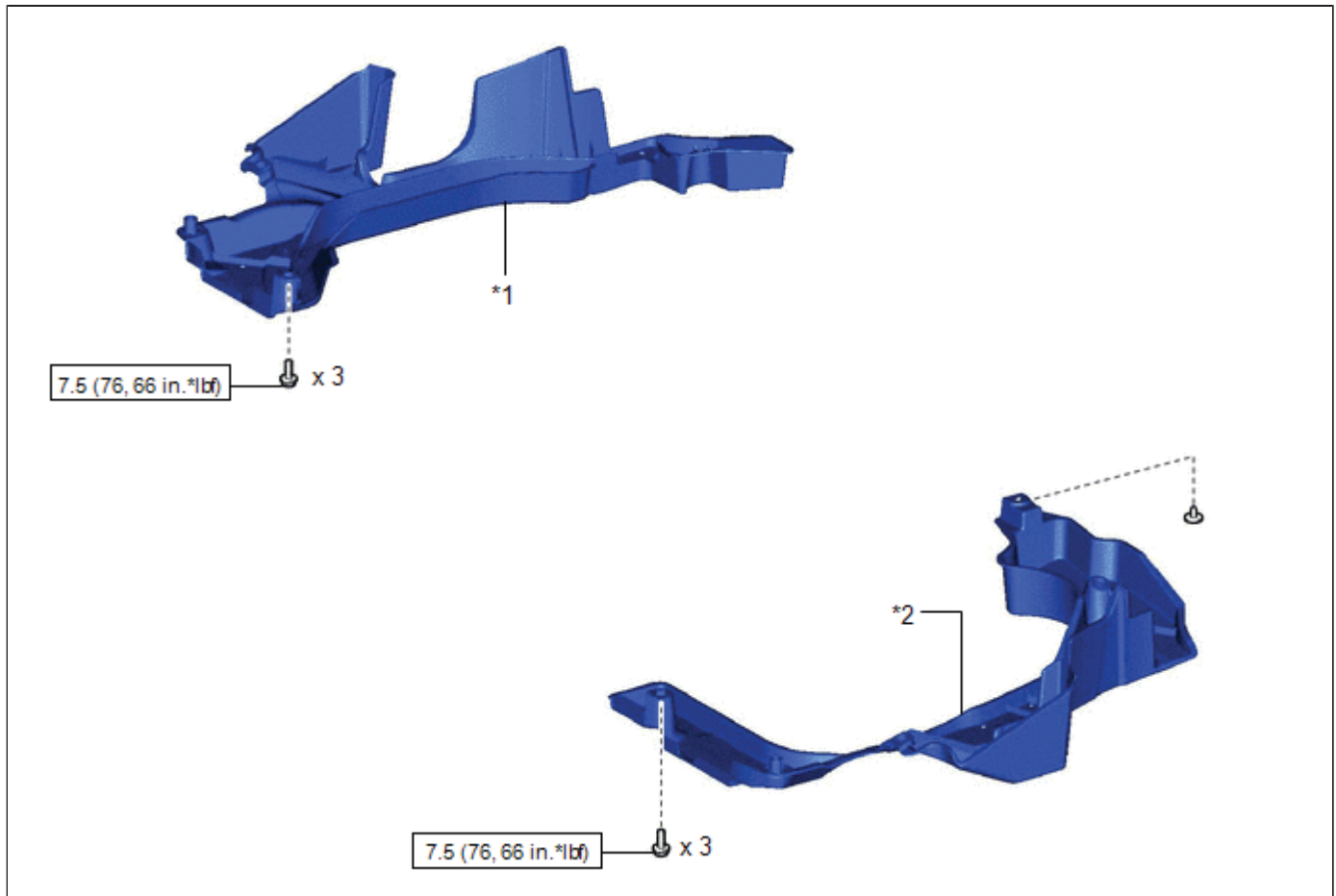

*1	NO. 1 FLOOR UNDER COVER ASSEMBLY	*2	REAR FLOOR SIDE MEMBER COVER LH
	N*m (kgf*cm, ft.*lbf): Specified torque	-	-

ILLUSTRATION

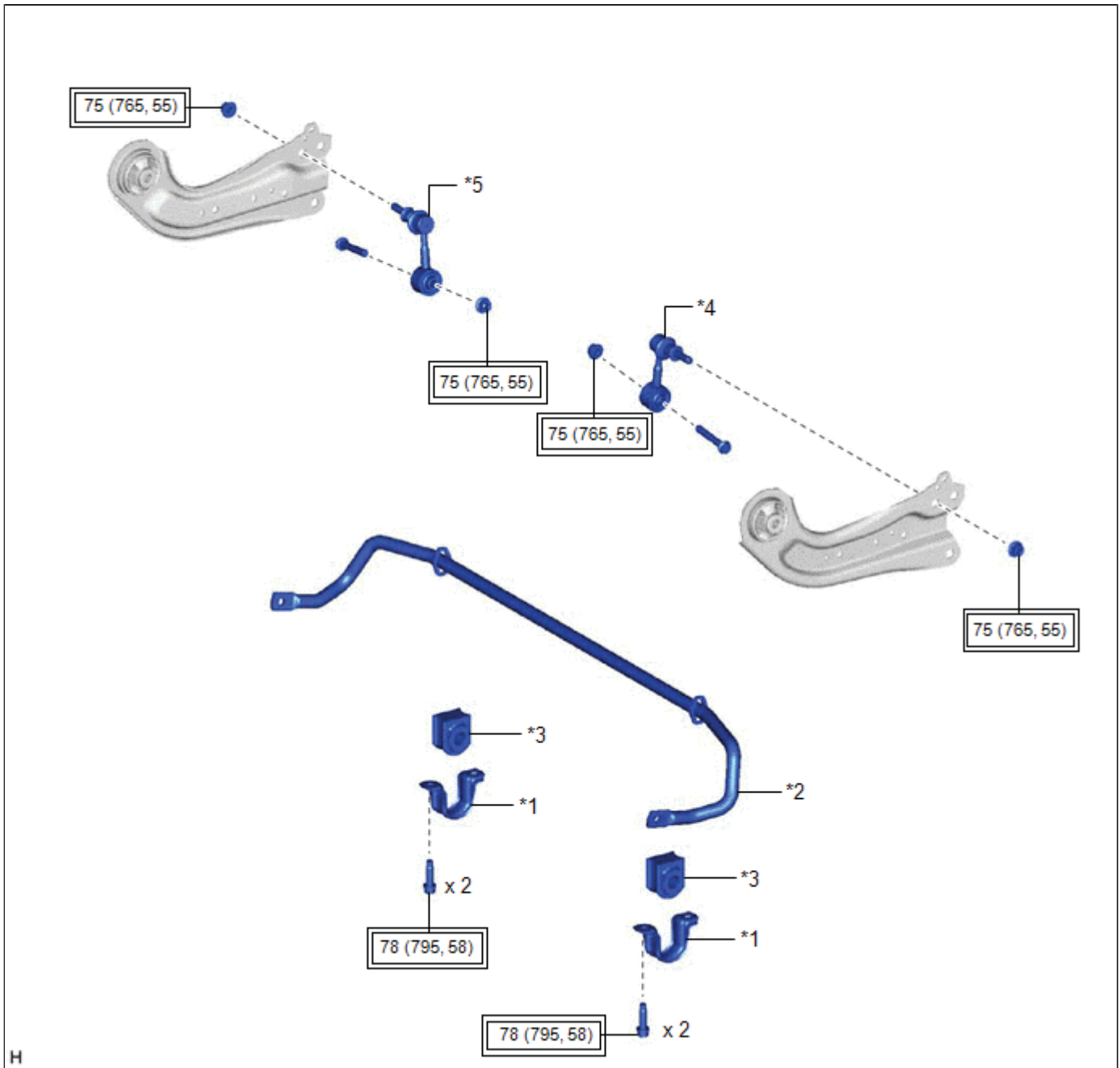

H

*1	REAR NO. 1 STABILIZER BAR BRACKET	*2	REAR STABILIZER BAR
*3	REAR STABILIZER BUSHING	*4	REAR STABILIZER LINK ASSEMBLY LH
*5	REAR STABILIZER LINK ASSEMBLY RH	-	-
	Tightening torque for "Major areas involving basic vehicle performance such as moving/turning/stopping" : N*m (kgf*cm, ft.*lbf)	-	-

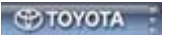

Last Modified: 01-14-2019	6.8:8.0.48	Doc ID: RM10000000RMLA
Model Year Start: 2016	Model: Prius	Prod Date Range: [11/2015 - 12/2018]
Title: REAR SUSPENSION: REAR STABILIZER BAR: INSPECTION; 2016 - 2018 MY Prius [11/2015 - 12/2018]		

INSPECTION

PROCEDURE

1. INSPECT REAR STABILIZER LINK ASSEMBLY

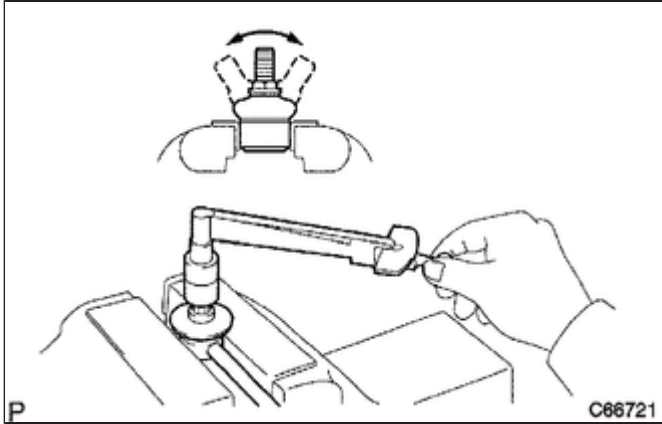

(a) Inspect the turning torque of the ball joint.

(1) Secure the rear stabilizer link assembly in a vise using aluminum plates.

NOTICE:

Do not overtighten the vise.

(2) Install the nut to the rear stabilizer link assembly stud.

(3) Move the stud back and forth several times. Using a torque wrench, turn the stud continuously at a rate of 3 to 5 seconds per turn and take the torque reading on the 5th turn.

Standard Turning Torque

SPECIFIED CONDITION
0.05 to 1.96 N*m
0.6 to 19 kgf*cm
0.5 to 17 in.*lbf

HINT:

If the turning torque is not within the specified range, replace the rear stabilizer link assembly with a new one.

(4) Turn the stud to check that the stud does not catch and there is no play

HINT:

If the stud catches or there is play while turning, replace the rear stabilizer link assembly with a new one.

(b) Inspect the dust cover.

(1) Check that the dust cover is not cracked and that there is no grease on it.

HINT:

If the dust cover is cracked or there is grease on it, replace the rear stabilizer link assembly with a new one.



Last Modified: 01-14-2019	6.8:8.0.48	Doc ID: RM10000000RML9
Model Year Start: 2016	Model: Prius	Prod Date Range: [11/2015 - 12/2018]
Title: REAR SUSPENSION: REAR STABILIZER BAR: INSTALLATION; 2016 - 2018 MY Prius [11/2015 - 12/2018]		

INSTALLATION

PROCEDURE

1. INSTALL REAR STABILIZER BUSHING

(a) Install the 2 rear stabilizer bushings to the rear stabilizer bar.

NOTICE:

Be sure to install the rear stabilizer bushings so that each cutout faces the front of the vehicle.

2. INSTALL REAR NO. 1 STABILIZER BAR BRACKET

(a) Install the 2 rear No. 1 stabilizer bar brackets to the 2 rear stabilizer bushings.

NOTICE:

Be sure to install the rear No. 1 stabilizer bar brackets so that each arrow mark faces the front of the vehicle.

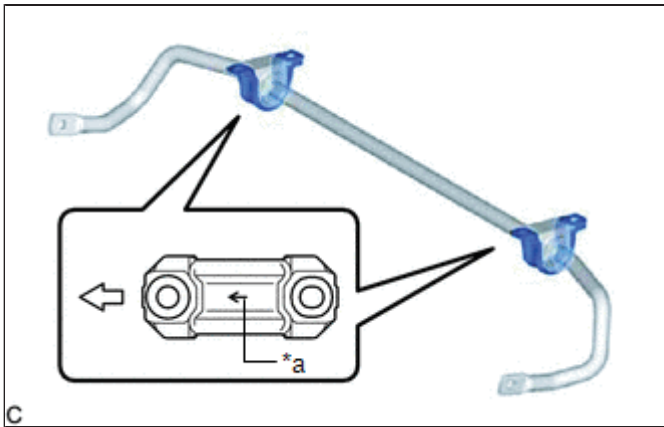

*a	Arrow Mark
	Front of the Vehicle

3. INSTALL REAR STABILIZER BAR

(a) Install the rear stabilizer bar, 2 rear No. 1 stabilizer bar brackets and 2 rear stabilizer bushings to the rear suspension member sub-assembly with the 4 bolts.

Torque:

78 N·m { 795 kgf·cm, 58 ft·lbf }

NOTICE:

- Ensure that the identification mark faces the right side of the vehicle.
- Temporarily tighten bolt (A) and then fully tighten the 2

bolts in the order of (B) and (A).

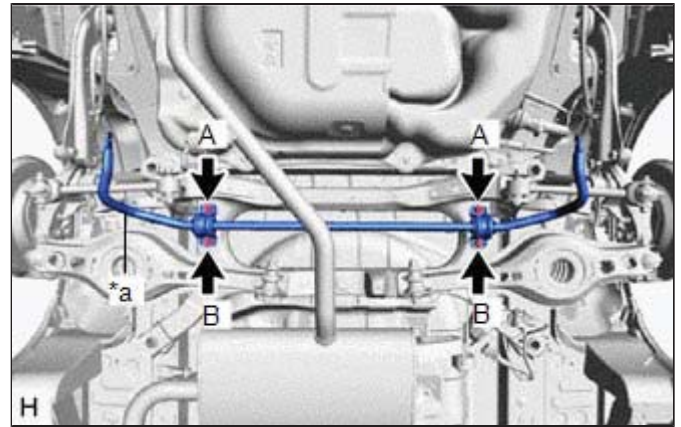

*a	Identification Mark
----	---------------------

4. STABILIZE SUSPENSION

Click here [INFO](#)

5. INSTALL REAR STABILIZER LINK ASSEMBLY LH

(a) Install the rear stabilizer link assembly LH with the nut (A).

Torque:

75 N·m { 765 kgf·cm, 55 ft·lbf }

HINT:

If the ball joint turns together with the nut, use a 6 mm hexagon socket wrench to hold the stud bolt.

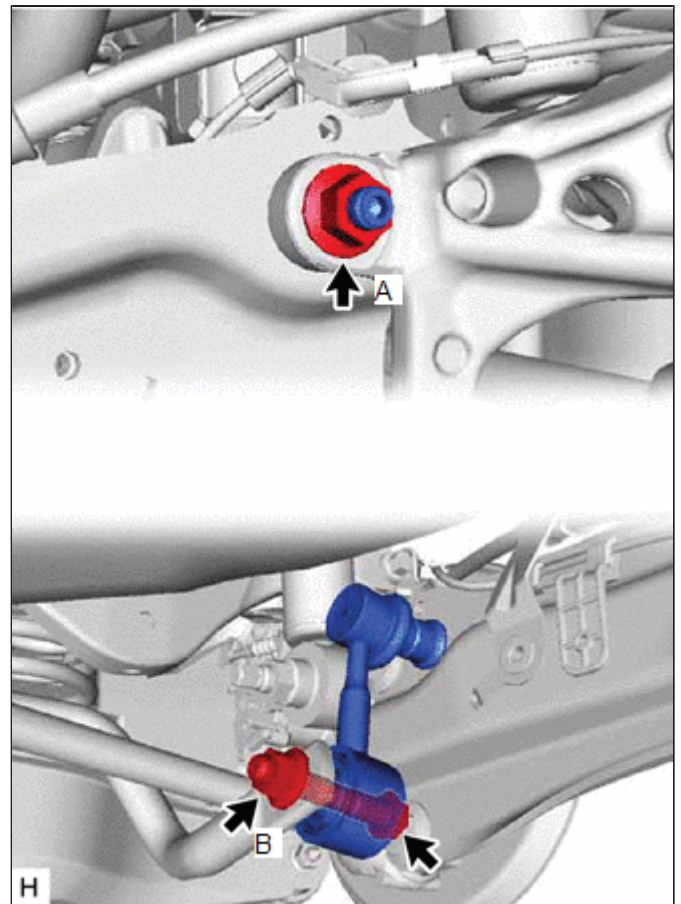

(b) Install the rear stabilizer link assembly LH with the bolt and nut (B).

Torque:

75 N·m { 765 kgf·cm, 55 ft·lbf }

NOTICE:

Because the bolt has its own stopper, do not turn the bolt. Tighten the nut with the bolt secured.

6. INSTALL REAR STABILIZER LINK ASSEMBLY RH

HINT:

Perform the same procedure as for the LH side.

7. INSTALL REAR FLOOR SIDE MEMBER COVER LH

Click here 

8. INSTALL NO. 1 FLOOR UNDER COVER ASSEMBLY

Click here 

9. INSTALL REAR WHEEL

Click here 

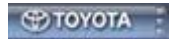

Last Modified: 01-14-2019	6.8:8.0.48	Doc ID: RM100000000RMLC
Model Year Start: 2016	Model: Prius	Prod Date Range: [11/2015 - 12/2018]
Title: REAR SUSPENSION: REAR STABILIZER BAR: REMOVAL; 2016 - 2018 MY Prius [11/2015 - 12/2018]		

REMOVAL

PROCEDURE

1. REMOVE REAR WHEEL

Click here [INFO](#)

2. REMOVE REAR FLOOR SIDE MEMBER COVER LH

Click here [INFO](#)

3. REMOVE NO. 1 FLOOR UNDER COVER ASSEMBLY

Click here [INFO](#)

4. REMOVE REAR STABILIZER LINK ASSEMBLY LH

(a) Loosen the nut (A) of the rear stabilizer link assembly LH.

HINT:

If the ball joint turns together with the nut, use a 6 mm hexagon socket wrench to hold the stud bolt.

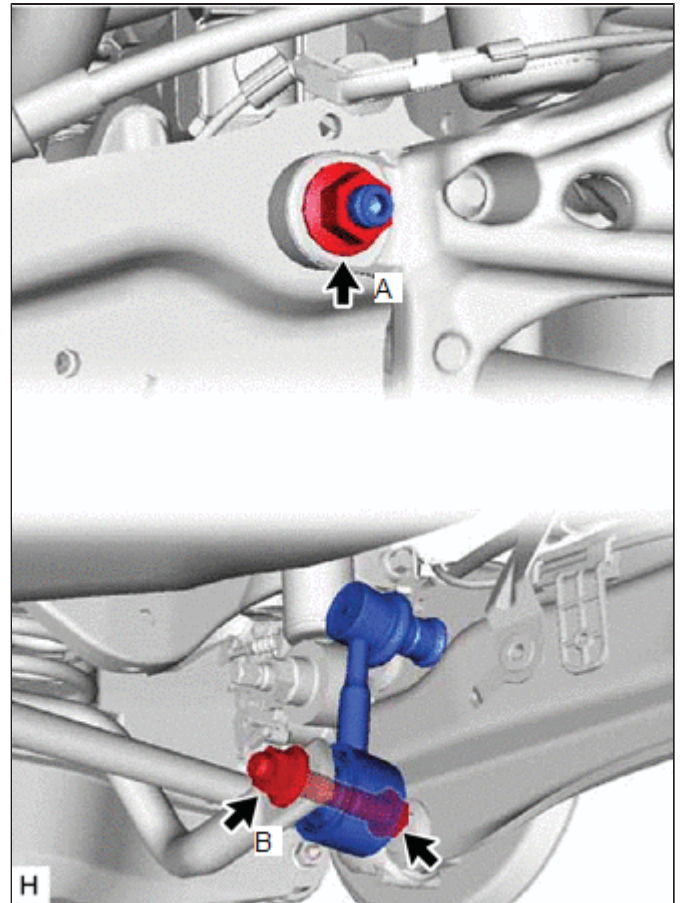

(b) Loosen the nut (B) of the rear stabilizer link assembly LH.

NOTICE:

Because the bolt has its own stopper, do not turn the bolt. Loosen the nut with the bolt secured.

(c) Using a jack and a wooden block, support the rear No. 2 suspension arm assembly.

NOTICE:

- When jacking up the rear No. 2 suspension arm assembly, be sure to jack it up slowly.
- Make sure to perform this operation with the vehicle kept as low as possible.

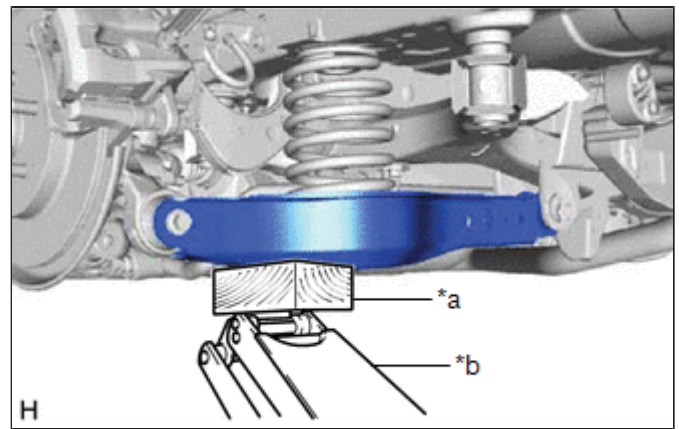

*a	Wooden Block
*b	Jack

(d) Remove the bolt, 2 nuts and rear stabilizer link assembly LH.

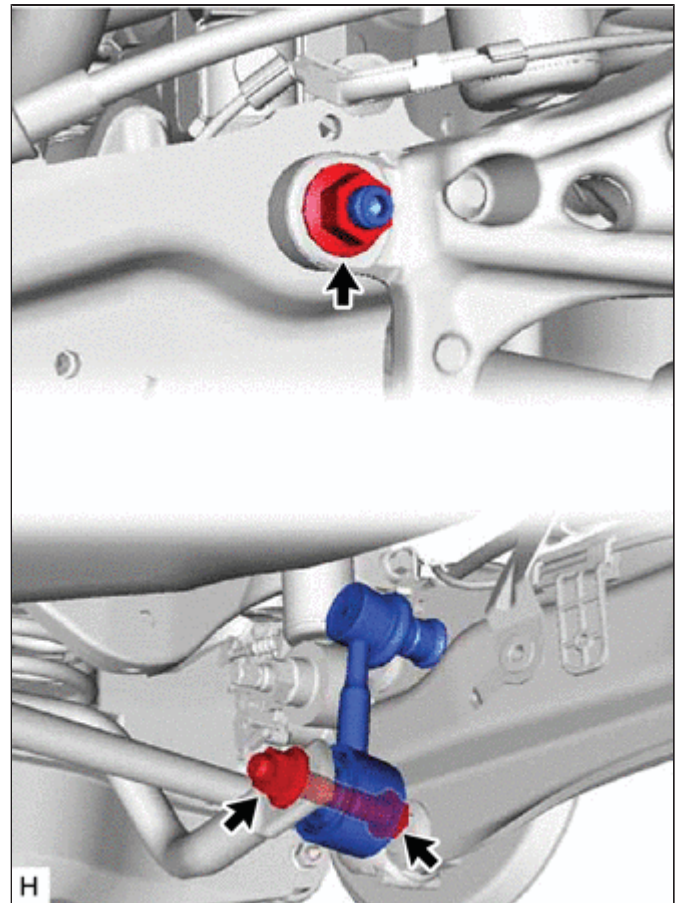

5. REMOVE REAR STABILIZER LINK ASSEMBLY RH

HINT:

Perform the same procedure as for the LH side.

6. REMOVE REAR STABILIZER BAR

- (a) Remove the 4 bolts, rear stabilizer bar, 2 rear No. 1 stabilizer bar brackets and 2 rear stabilizer bushings from the rear suspension member sub-assembly.

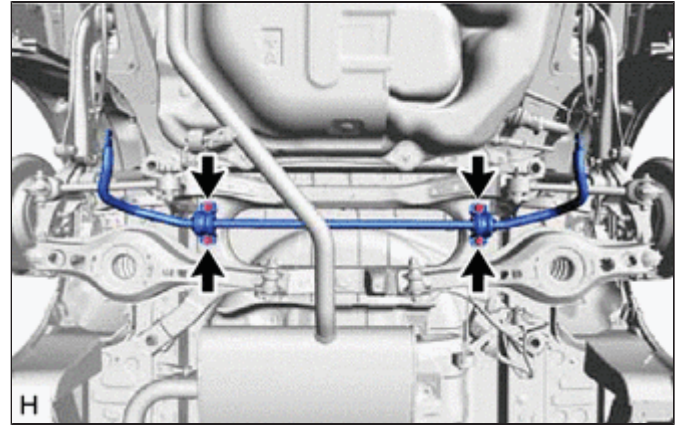

7. REMOVE REAR NO. 1 STABILIZER BAR BRACKET

- (a) Remove the 2 rear No. 1 stabilizer bar brackets from the 2 rear stabilizer bushings.



8. REMOVE REAR STABILIZER BUSHING

- (a) Remove the 2 rear stabilizer bushings from the rear stabilizer bar.

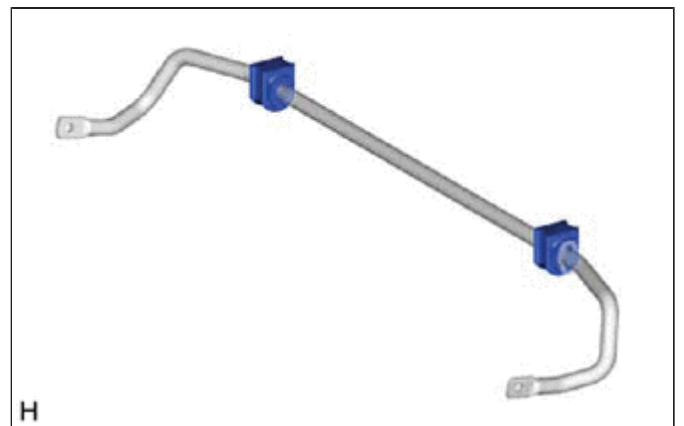

Last Modified: 01-14-2019

6.8:8.0.48

Doc ID: RM100000000RMLE

Model Year Start: 2016

Model: Prius

Prod Date Range: [11/2015 - 12/2018]

Title: REAR SUSPENSION: REAR SUSPENSION MEMBER: COMPONENTS; 2016 - 2018 MY Prius [11/2015 - 12/2018]

COMPONENTS

ILLUSTRATION

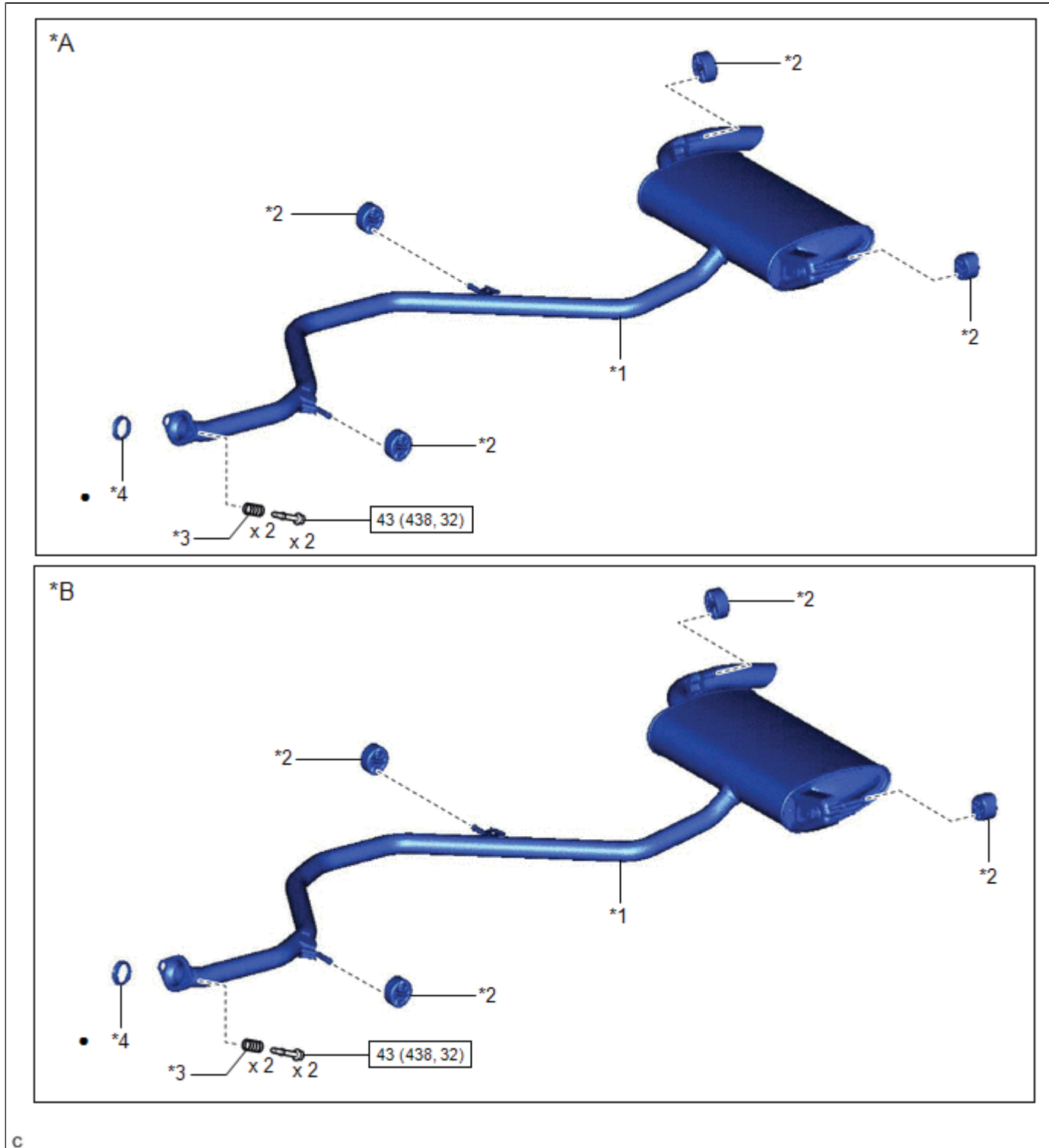



C

*A	w/ Exhaust Heat Recirculation System	*B	w/o Exhaust Heat Recirculation
----	--------------------------------------	----	--------------------------------

			System
*1	TAIL EXHAUST PIPE ASSEMBLY	*2	EXHAUST PIPE SUPPORT
*3	COMPRESSION SPRING	*4	EXHAUST PIPE GASKET
	N*m (kgf*cm, ft.*lbf): Specified torque	•	Non-reusable part

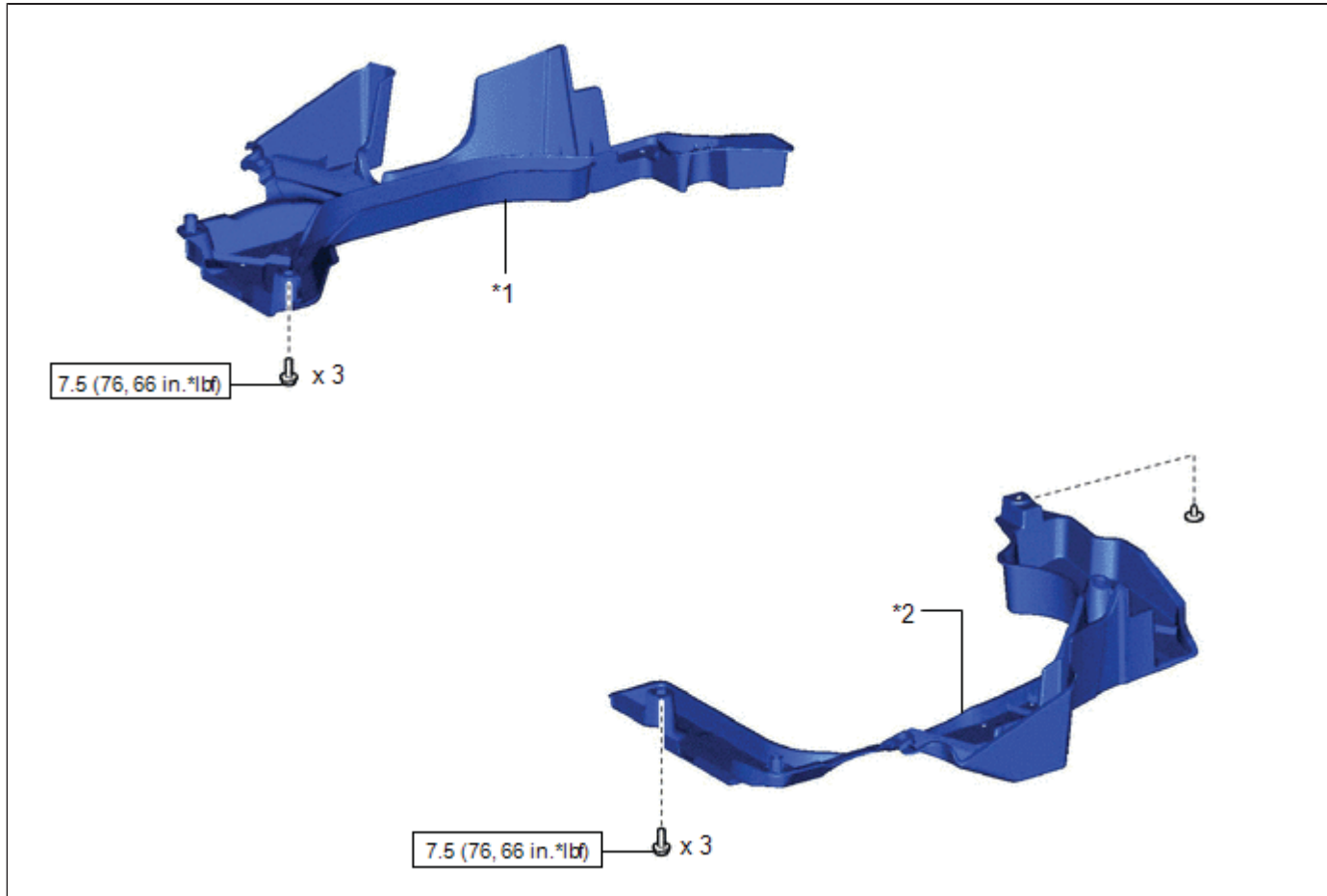
ILLUSTRATION



*1	NO. 1 FLOOR UNDER COVER ASSEMBLY	*2	REAR FLOOR SIDE MEMBER COVER LH
	N*m (kgf*cm, ft.*lbf): Specified torque	-	-

ILLUSTRATION

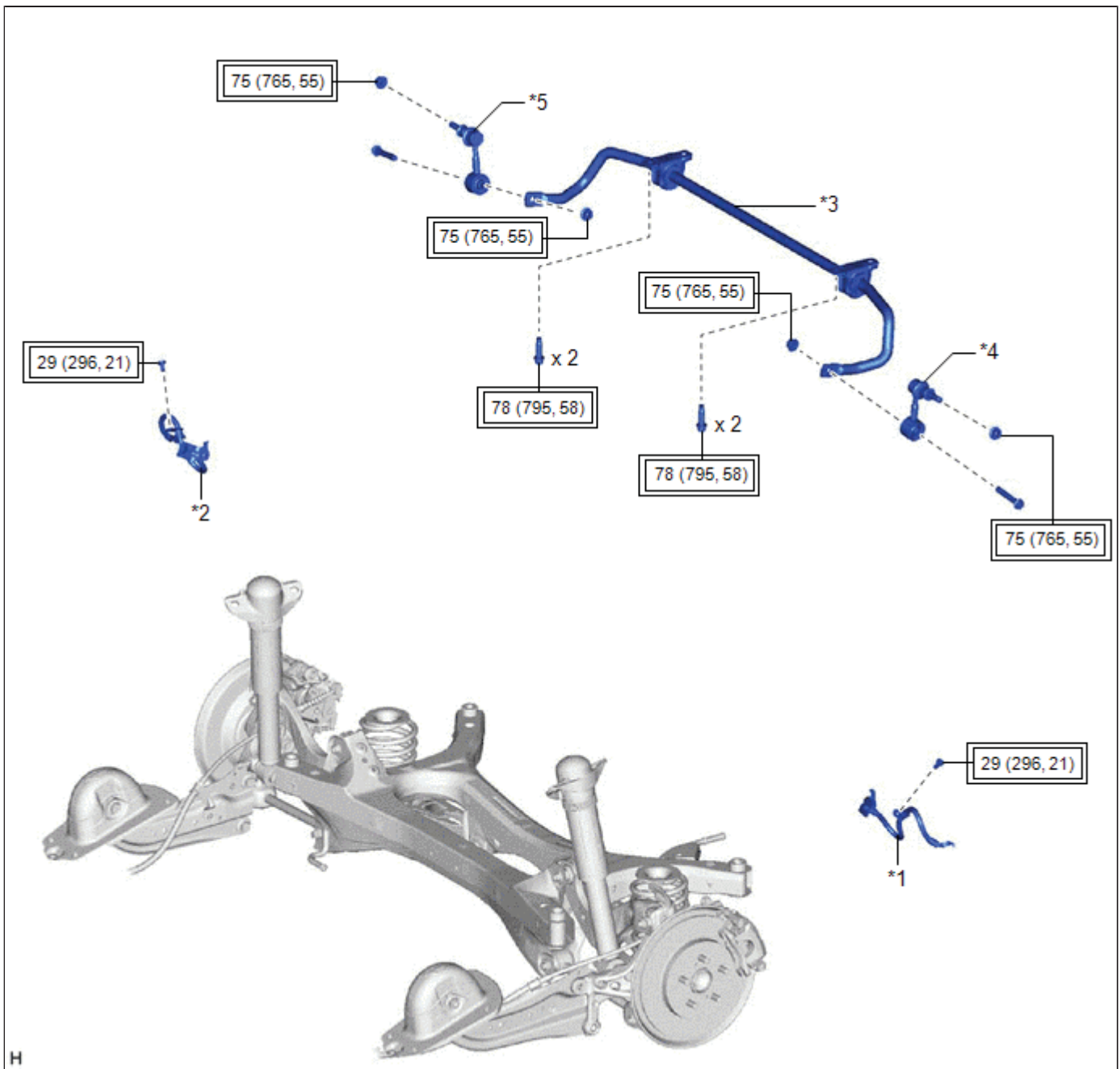

H

*1	REAR FLEXIBLE HOSE LH	*2	REAR FLEXIBLE HOSE RH
*3	REAR STABILIZER BAR	*4	REAR STABILIZER LINK ASSEMBLY LH
*5	REAR STABILIZER LINK ASSEMBLY RH	-	-
	Tightening torque for "Major areas involving basic vehicle performance such as moving/turning/stopping" : N*m (kgf*cm, ft.*lbf)	-	-

ILLUSTRATION

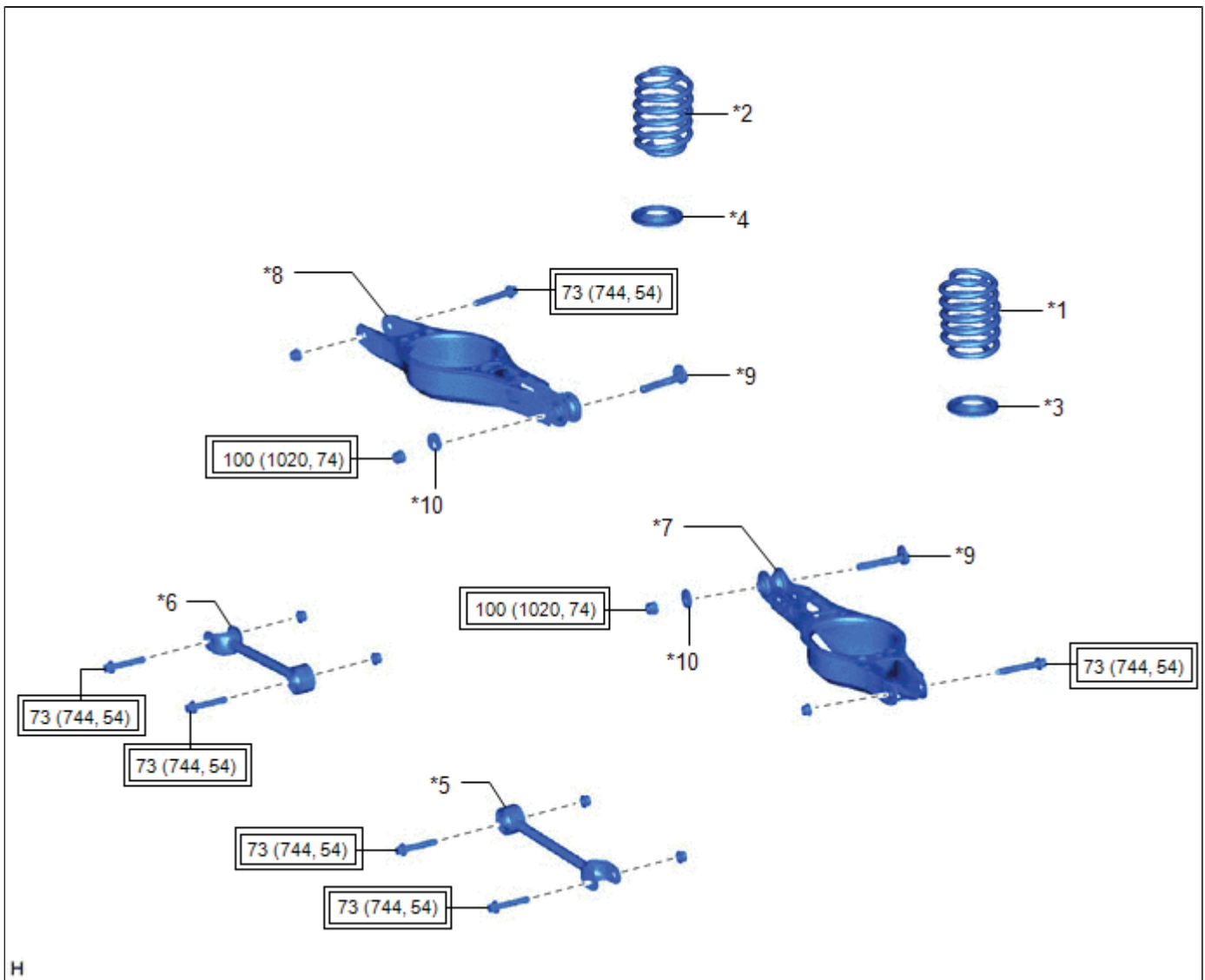

*1	REAR COIL SPRING LH	*2	REAR COIL SPRING RH
*3	REAR LOWER COIL SPRING INSULATOR LH	*4	REAR LOWER COIL SPRING INSULATOR RH
*5	REAR NO. 1 SUSPENSION ARM ASSEMBLY LH	*6	REAR NO. 1 SUSPENSION ARM ASSEMBLY RH
*7	REAR NO. 2 SUSPENSION ARM ASSEMBLY LH	*8	REAR NO. 2 SUSPENSION ARM ASSEMBLY RH
*9	REAR SUSPENSION TOE ADJUST CAM SUB-ASSEMBLY	*10	NO. 2 CAMBER ADJUST CAM
	Tightening torque for "Major areas involving basic vehicle performance such as moving/turning/stopping" : N*m (kgf*cm, ft.*lbf)	-	-

ILLUSTRATION

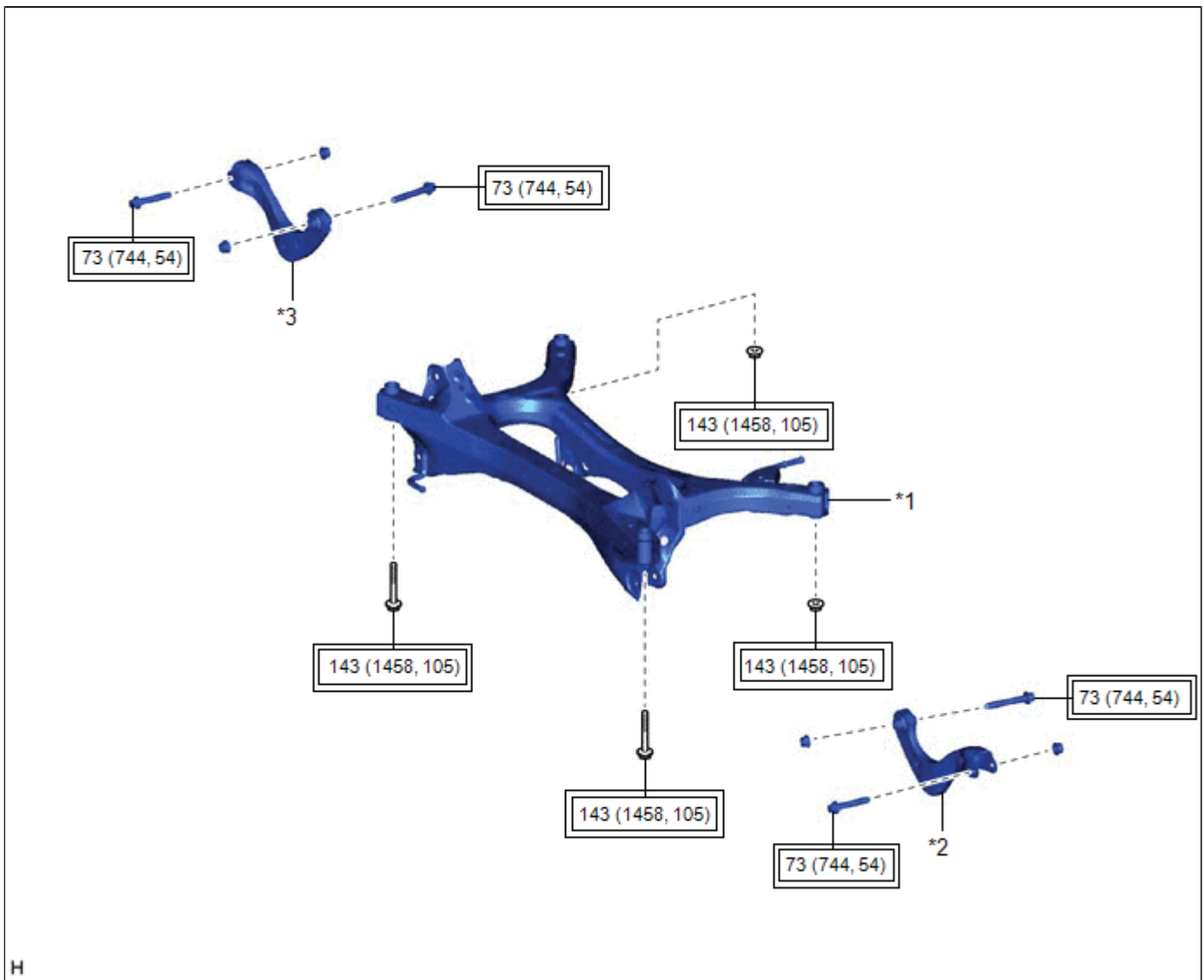

*1	REAR SUSPENSION MEMBER SUB-ASSEMBLY	*2	REAR UPPER CONTROL ARM ASSEMBLY LH
*3	REAR UPPER CONTROL ARM ASSEMBLY RH	-	-
	Tightening torque for "Major areas involving basic vehicle performance such as moving/turning/stopping" : N*m (kgf*cm, ft.*lbf)	-	-

ILLUSTRATION

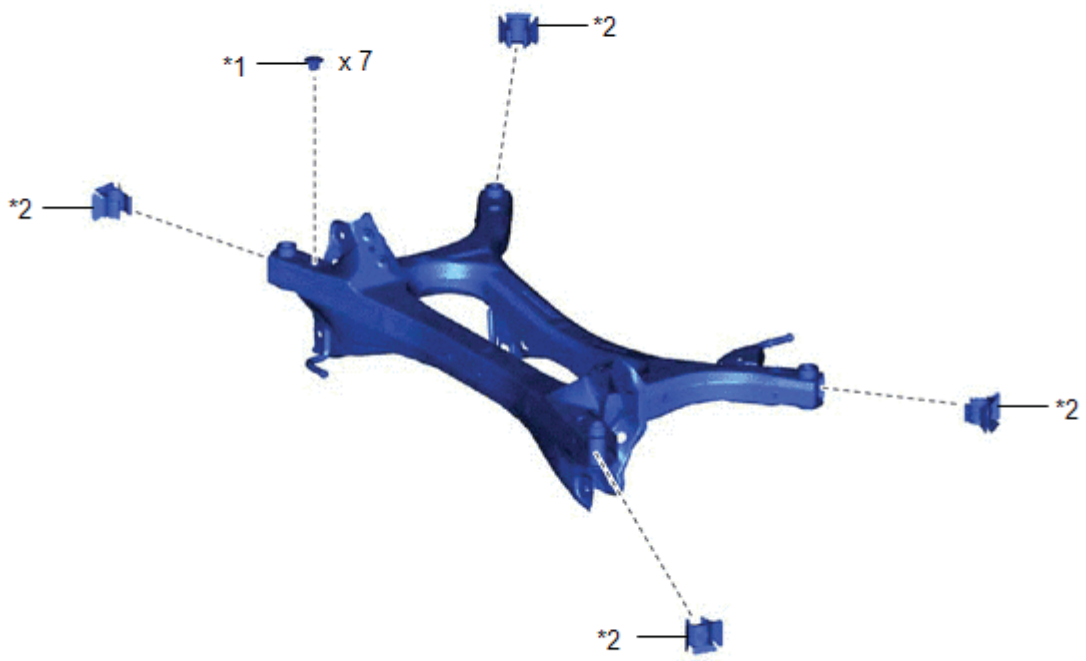

H

*1	HOLE PLUG	*2	REAR SUSPENSION MEMBER HOLE COVER
----	-----------	----	-----------------------------------

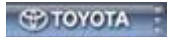

Last Modified: 01-14-2019	6.8:8.0.48	Doc ID: RM10000000RMLD
Model Year Start: 2016	Model: Prius	Prod Date Range: [11/2015 - 12/2018]
Title: REAR SUSPENSION: REAR SUSPENSION MEMBER: INSTALLATION; 2016 - 2018 MY Prius [11/2015 - 12/2018]		

INSTALLATION

PROCEDURE

1. INSTALL HOLE PLUG

- (a) Install the 7 hole plugs to the rear suspension member sub-assembly as shown in the illustration.

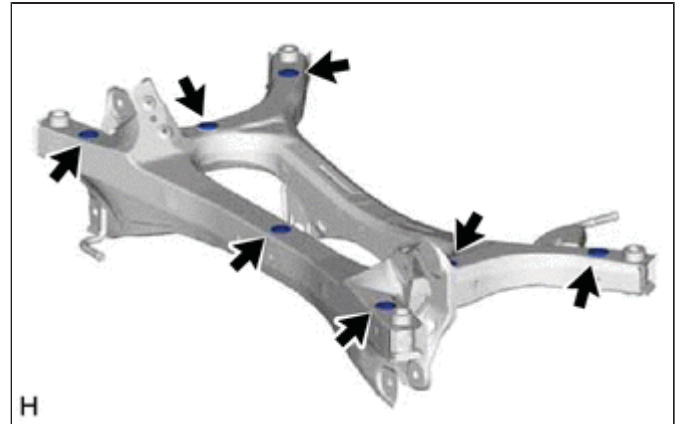

2. INSTALL REAR SUSPENSION MEMBER HOLE COVER

- (a) Install the 4 rear suspension member hole covers to the rear suspension member sub-assembly.

3. INSTALL REAR UPPER CONTROL ARM ASSEMBLY LH

Click here [INFO](#)

4. INSTALL REAR UPPER CONTROL ARM ASSEMBLY RH

HINT:

Perform the same procedure as for the LH side.

5. INSTALL REAR SUSPENSION MEMBER SUB-ASSEMBLY

- (a) Using an engine lifter and 4 attachments or equivalent tools, support the rear suspension member sub-assembly as shown in the illustration.

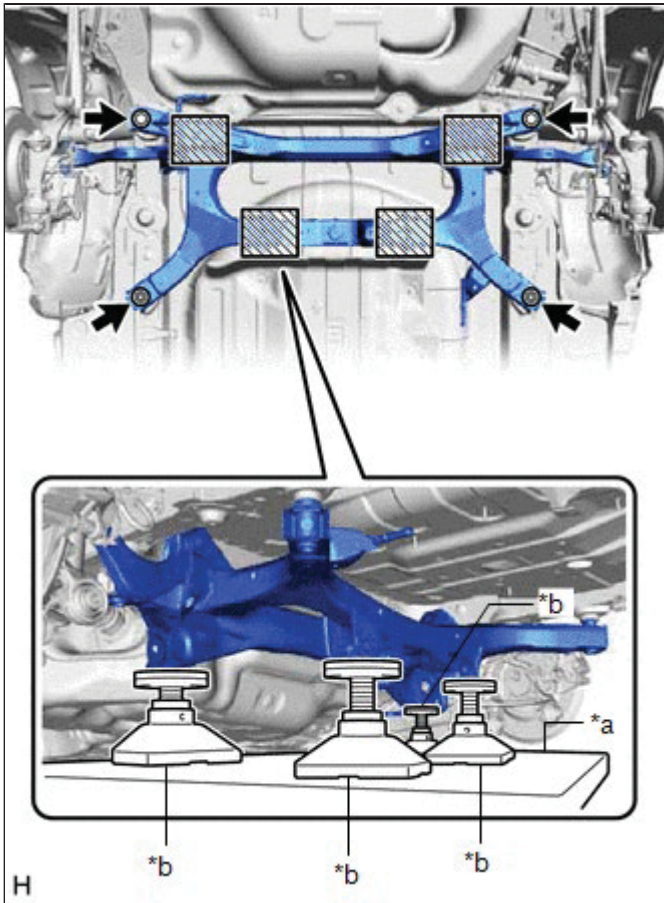

*a	Engine Lifter
*b	Attachment
	Attachment and Wooden Block Placement Location

CAUTION:

- The rear suspension member sub-assembly is a very heavy component. Make sure that it is supported securely.
- If the rear suspension member sub-assembly is not securely supported, it may drop, resulting in serious injury.

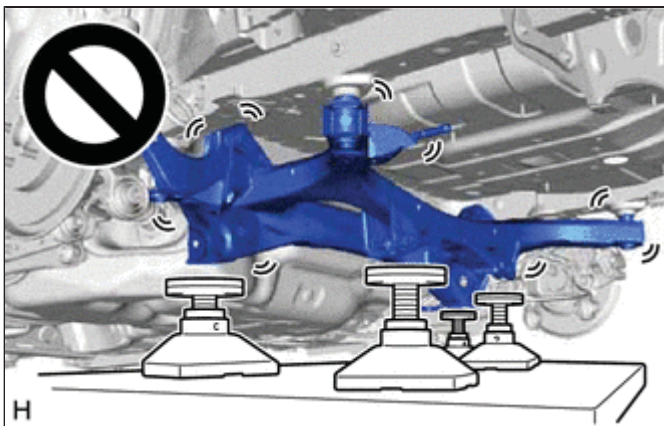

NOTICE:

- Use attachments and wooden blocks to keep the rear suspension member sub-assembly level.
- Keep supporting the rear suspension member sub-assembly until the installation has been completed.

(b) Raise the rear suspension member sub-assembly until there is no clearance between the rear suspension member

sub-assembly and vehicle.

(c) Install the rear suspension member sub-assembly with the 2 bolts and 2 nuts.

Torque:

143 N·m { 1458 kgf·cm, 105 ft·lbf }

6. TEMPORARILY INSTALL REAR UPPER CONTROL ARM ASSEMBLY LH

(a) Temporarily install the rear upper control arm assembly LH to the rear axle carrier sub-assembly LH with the bolt and nut.

NOTICE:

- Insert the bolt with the threaded end facing the rear of the vehicle.
- Because the nut has its own stopper, do not turn the nut. Tighten the bolt with the nut secured.

7. TEMPORARILY INSTALL REAR UPPER CONTROL ARM ASSEMBLY RH

HINT:

Perform the same procedure as for the LH side.

8. TEMPORARILY INSTALL REAR NO. 1 SUSPENSION ARM ASSEMBLY LH

Click here [INFO](#)

9. TEMPORARILY INSTALL REAR NO. 1 SUSPENSION ARM ASSEMBLY RH

HINT:

Perform the same procedure as for the LH side.

10. TEMPORARILY INSTALL REAR NO. 2 SUSPENSION ARM ASSEMBLY LH

Click here [INFO](#)

11. TEMPORARILY INSTALL REAR NO. 2 SUSPENSION ARM ASSEMBLY RH

HINT:

Perform the same procedure as for the LH side.

12. INSTALL REAR LOWER COIL SPRING INSULATOR LH

Click here [INFO](#)

13. INSTALL REAR LOWER COIL SPRING INSULATOR RH

HINT:

Perform the same procedure as for the LH side.

14. INSTALL REAR COIL SPRING LH

Click here [INFO](#)

15. INSTALL REAR COIL SPRING RH

HINT:

Perform the same procedure as for the LH side.

16. INSTALL REAR STABILIZER BAR

Click here [INFO](#)

17. CONNECT REAR FLEXIBLE HOSE LH

(a) Connect the rear flexible hose LH to the flexible hose bracket with the bolt.

Torque:

29 N·m {296 kgf·cm, 21 ft·lbf}

18. CONNECT REAR FLEXIBLE HOSE RH

HINT:

Perform the same procedure as for the LH side.

19. STABILIZE SUSPENSION

Click here [INFO](#)

20. INSTALL REAR STABILIZER LINK ASSEMBLY LH

Click here [INFO](#)

21. INSTALL REAR STABILIZER LINK ASSEMBLY RH

HINT:

Perform the same procedure as for the LH side.

22. INSTALL REAR NO. 1 SUSPENSION ARM ASSEMBLY LH

Click here [INFO](#)

23. INSTALL REAR NO. 1 SUSPENSION ARM ASSEMBLY RH

HINT:

Perform the same procedure as for the LH side.

24. INSTALL REAR NO. 2 SUSPENSION ARM ASSEMBLY LH

(a) Install the rear No. 2 suspension arm assembly LH (rear axle carrier sub-assembly side) with the bolt.

Click here [INFO](#)

25. INSTALL REAR NO. 2 SUSPENSION ARM ASSEMBLY RH

HINT:

Perform the same procedure as for the LH side.

26. INSTALL REAR UPPER CONTROL ARM ASSEMBLY LH

(a) Install the rear upper control arm assembly LH to the rear axle carrier sub-assembly LH with the bolt.

Torque:

73 N·m {744 kgf·cm, 54 ft·lbf}

NOTICE:

Because the nut has its own stopper, do not turn the nut. Tighten the bolt with the nut secured.

27. INSTALL REAR UPPER CONTROL ARM ASSEMBLY RH

HINT:

Perform the same procedure as for the LH side.

28. INSTALL REAR FLOOR SIDE MEMBER COVER LH

Click here [INFO](#)

29. INSTALL NO. 1 FLOOR UNDER COVER ASSEMBLY

Click here [INFO](#)

30. INSTALL TAIL EXHAUST PIPE ASSEMBLY

Click here [INFO](#)

31. INSTALL REAR WHEEL

Click here [INFO](#)

32. INSTALL REAR NO. 2 SUSPENSION ARM ASSEMBLY LH

(a) Install the rear No. 2 suspension arm assembly LH (rear suspension member sub-assembly side) with the nut.

Click here [INFO](#)

33. INSTALL REAR NO. 2 SUSPENSION ARM ASSEMBLY RH

HINT:

Perform the same procedure as for the LH side.

34. INSPECT FOR EXHAUST GAS LEAK

Click here [INFO](#)

35. INSPECT AND ADJUST REAR WHEEL ALIGNMENT

Click here [INFO](#)

36. PERFORM INITIALIZATION

Intelligent clearance sonar system	INFO
Simple advanced parking guidance system	

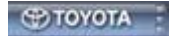

Last Modified: 01-14-2019	6.8:8.0.48	Doc ID: RM10000000RMLF
Model Year Start: 2016	Model: Prius	Prod Date Range: [11/2015 - 12/2018]
Title: REAR SUSPENSION: REAR SUSPENSION MEMBER: REMOVAL; 2016 - 2018 MY Prius [11/2015 - 12/2018]		

REMOVAL

CAUTION / NOTICE / HINT

The necessary procedures (adjustment, calibration, initialization, or registration) that must be performed after parts are removed and installed, or replaced during rear suspension member sub-assembly removal/installation are shown below.

Necessary Procedures After Parts Removed/Installed/Replaced

REPLACED PART OR PERFORMED PROCEDURE	NECESSARY PROCEDURE	EFFECT/INOPERATIVE FUNCTION WHEN NECESSARY PROCEDURE NOT PERFORMED	LINK
Rear wheel alignment adjustment	<ol style="list-style-type: none"> 1. Clear zero point calibration data. 2. Perform yaw rate and acceleration sensor zero point calibration. 	<ul style="list-style-type: none"> • DTCs are stored • ABS warning light illuminates • Brake warning light/yellow (minor malfunction) illuminates • Slip indicator light illuminates • VSC disabled or malfunctions 	INFO
Suspension, tires, etc. (The vehicle height changes because of suspension or tire replacement)	<ul style="list-style-type: none"> • Ultrasonic sensor detection angle • Ultrasonic sensor detection angle registration 	<ul style="list-style-type: none"> • Intelligent clearance sonar system • Simple advanced parking guidance system 	INFO
Gas leak from exhaust system is repaired	Inspection After Repair	<ul style="list-style-type: none"> • Poor idle, etc. • Engine start function, etc. 	INFO

CAUTION:

To prevent burns, do not touch the engine, exhaust pipe or other high temperature components while the engine is hot.



PROCEDURE

1. REMOVE REAR WHEEL

Click here [INFO](#)

2. REMOVE TAIL EXHAUST PIPE ASSEMBLY

Click here [INFO](#)

3. REMOVE REAR FLOOR SIDE MEMBER COVER LH

Click here [INFO](#)

4. REMOVE NO. 1 FLOOR UNDER COVER ASSEMBLY

Click here [INFO](#)

5. SEPARATE REAR FLEXIBLE HOSE LH

(a) Remove the bolt and separate the rear flexible hose LH from the flexible hose bracket.

6. SEPARATE REAR FLEXIBLE HOSE RH

HINT:

Perform the same procedure as for the LH side.

7. REMOVE REAR STABILIZER LINK ASSEMBLY LH

Click here [INFO](#)

8. REMOVE REAR STABILIZER LINK ASSEMBLY RH

HINT:

Perform the same procedure as for the LH side.

9. REMOVE REAR STABILIZER BAR

Click here [INFO](#)

10. REMOVE REAR COIL SPRING LH

Click here [INFO](#)

11. REMOVE REAR COIL SPRING RH

HINT:

Perform the same procedure as for the LH side.

12. REMOVE REAR LOWER COIL SPRING INSULATOR LH

Click here [INFO](#)

13. REMOVE REAR LOWER COIL SPRING INSULATOR RH

HINT:

Perform the same procedure as for the LH side.

14. REMOVE REAR NO. 2 SUSPENSION ARM ASSEMBLY LH

Click here [INFO](#)

15. REMOVE REAR NO. 2 SUSPENSION ARM ASSEMBLY RH

HINT:

Perform the same procedure as for the LH side.

16. REMOVE REAR NO. 1 SUSPENSION ARM ASSEMBLY LH

Click here [INFO](#)

17. REMOVE REAR NO. 1 SUSPENSION ARM ASSEMBLY RH

HINT:

Perform the same procedure as for the LH side.

18. SEPARATE REAR UPPER CONTROL ARM ASSEMBLY LH

- (a) Remove the bolt and nut and separate the rear upper control arm assembly LH from the rear axle carrier sub-assembly LH.

NOTICE:

Because the nut has its own stopper, do not turn the nut. Loosen the bolt with the nut secured.

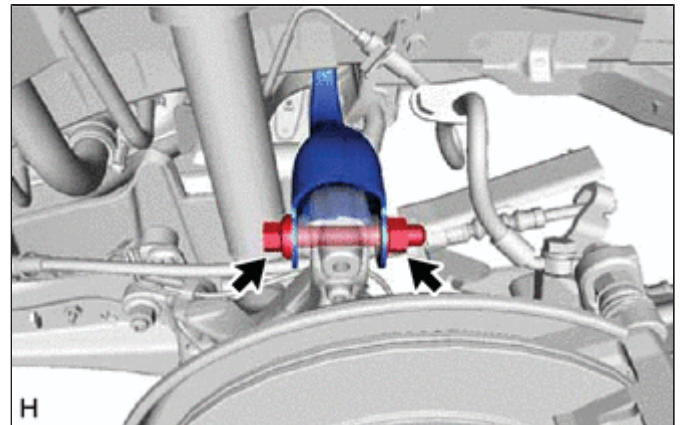

19. SEPARATE REAR UPPER CONTROL ARM ASSEMBLY RH

HINT:

Use the same procedure as for the LH side.

20. REMOVE REAR SUSPENSION MEMBER SUB-ASSEMBLY

- (a) Using an engine lifter and 4 attachments or equivalent tools, support the rear suspension member sub-assembly as shown in the illustration.

CAUTION:

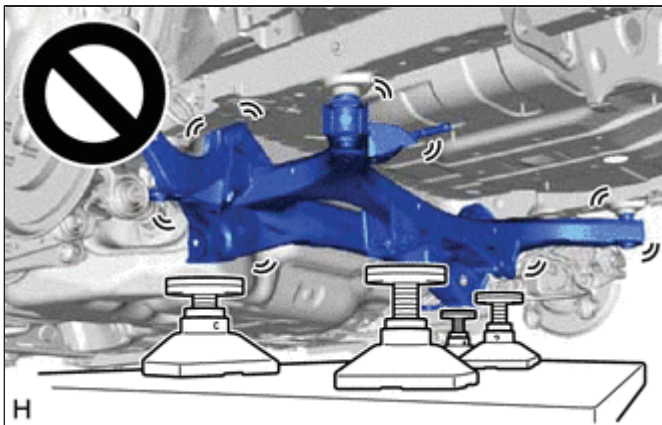

- The rear suspension member sub-assembly is a very heavy component. Make sure that it is supported securely.
- If the rear suspension member sub-assembly is not securely supported, it may drop, resulting in serious injury.

NOTICE:

Use attachments and wooden blocks to keep the rear suspension member sub-assembly level.

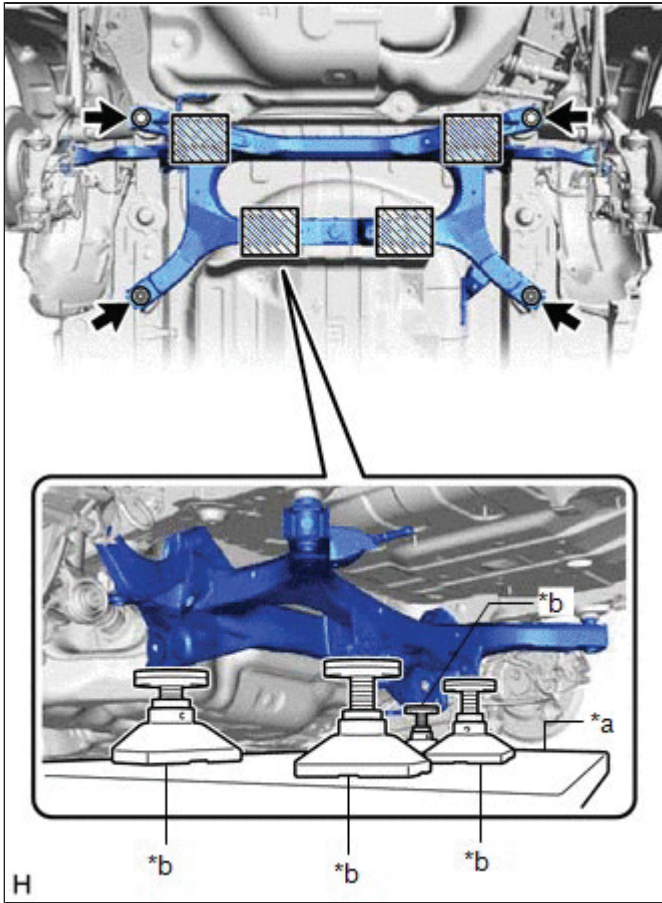

*a	Engine Lifter
*b	Attachment
	Attachment and Wooden Block Placement Location

(b) Remove the 2 bolts and 2 nuts.

(c) Slowly lower the rear suspension member sub-assembly.

NOTICE:

When lowering the rear suspension member sub-assembly, be careful not to damage the vehicle body or other components installed to the vehicle.

21. REMOVE REAR UPPER CONTROL ARM ASSEMBLY LH

Click here [INFO](#)

22. REMOVE REAR UPPER CONTROL ARM ASSEMBLY RH**HINT:**

Perform the same procedure as for the LH side.

23. REMOVE REAR SUSPENSION MEMBER HOLE COVER

(a) Remove the 4 rear suspension member hole covers from the rear suspension member sub-assembly as shown in the illustration.

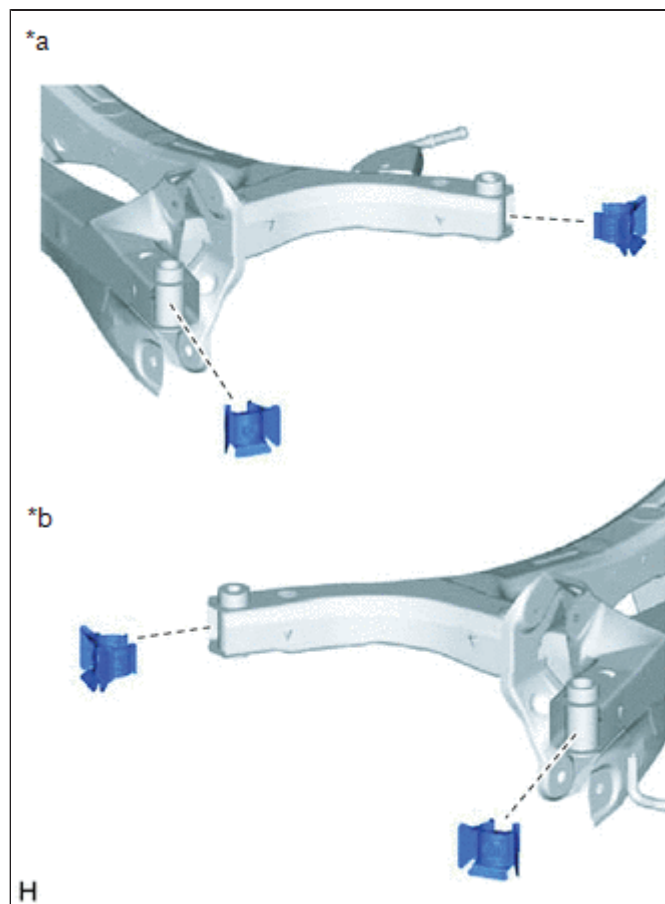

*a	for LH Side
*b	for RH Side

24. REMOVE HOLE PLUG

(a) Remove the 7 hole plugs from the rear suspension member sub-assembly as shown in the illustration.

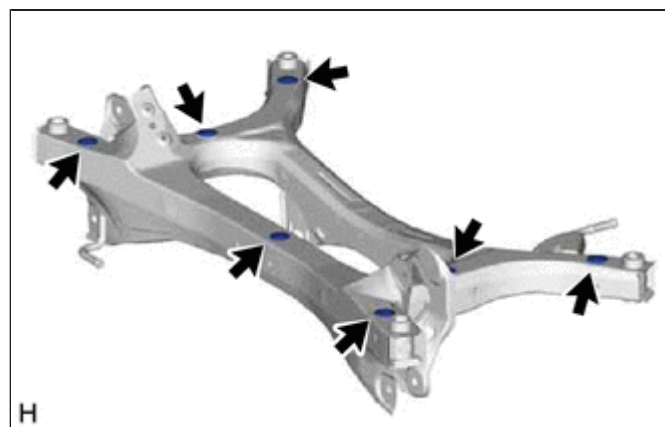

Last Modified: 01-14-2019	6.8:8.0.48	Doc ID: RM100000000RMKR
Model Year Start: 2016	Model: Prius	Prod Date Range: [11/2015 - 12/2018]
Title: REAR SUSPENSION: REAR SUSPENSION SYSTEM: PROBLEM SYMPTOMS TABLE; 2016 - 2018 MY Prius [11/2015 - 12/2018]		

PROBLEM SYMPTOMS TABLE

HINT:

Use the table below to help determine the cause of problem symptoms. If multiple suspected areas are listed, the potential causes of the symptoms are listed in order of probability in the "Suspected Area" column of the table. Check each symptom by checking the suspected areas in the order they are listed. Replace parts as necessary.

Rear Suspension System

SYMPTOM	SUSPECTED AREA	LINK
Vehicle pulls to one side while driving	Tires (worn or improperly inflated)	INFO INFO
	Rear wheel alignment (incorrect)	INFO
	Rear axle hub (worn)	INFO
	Rear shock absorber (worn)	INFO
	Rear coil spring (weak)	INFO
	Suspension parts (worn)	-
Bottoming	Vehicle (overloaded)	-
	Rear coil spring (weak)	INFO
	Rear shock absorber (worn)	INFO
Swaying/pitching	Tires (worn or improperly inflated)	INFO INFO
	Rear coil spring (weak)	INFO
	Rear shock absorber (worn)	INFO
	Rear stabilizer bar (bent or broken)	INFO
	Tires (worn or improperly inflated)	INFO INFO

Wheel shimmy	Wheels (out of balance)	INFO INFO
	Rear wheel alignment	INFO
	Rear upper control arm (worn)	INFO
	Rear No. 1 suspension arm (worn)	INFO
	Rear No. 2 suspension arm (worn)	INFO
	Rear trailing arm (worn)	INFO
	Rear shock absorber (worn)	INFO
	Rear axle hub (worn)	INFO
Abnormal tire wear	Tires (worn or improperly inflated)	INFO INFO
	Wheels (out of balance)	INFO INFO
	Rear wheel alignment	INFO
	Suspension parts (worn)	-

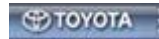

Last Modified: 01-14-2019	6.8:8.0.48	Doc ID: RM10000000RML7
Model Year Start: 2016	Model: Prius	Prod Date Range: [11/2015 - 12/2018]
Title: REAR SUSPENSION: REAR TRAILING ARM: COMPONENTS; 2016 - 2018 MY Prius [11/2015 - 12/2018]		

COMPONENTS

ILLUSTRATION

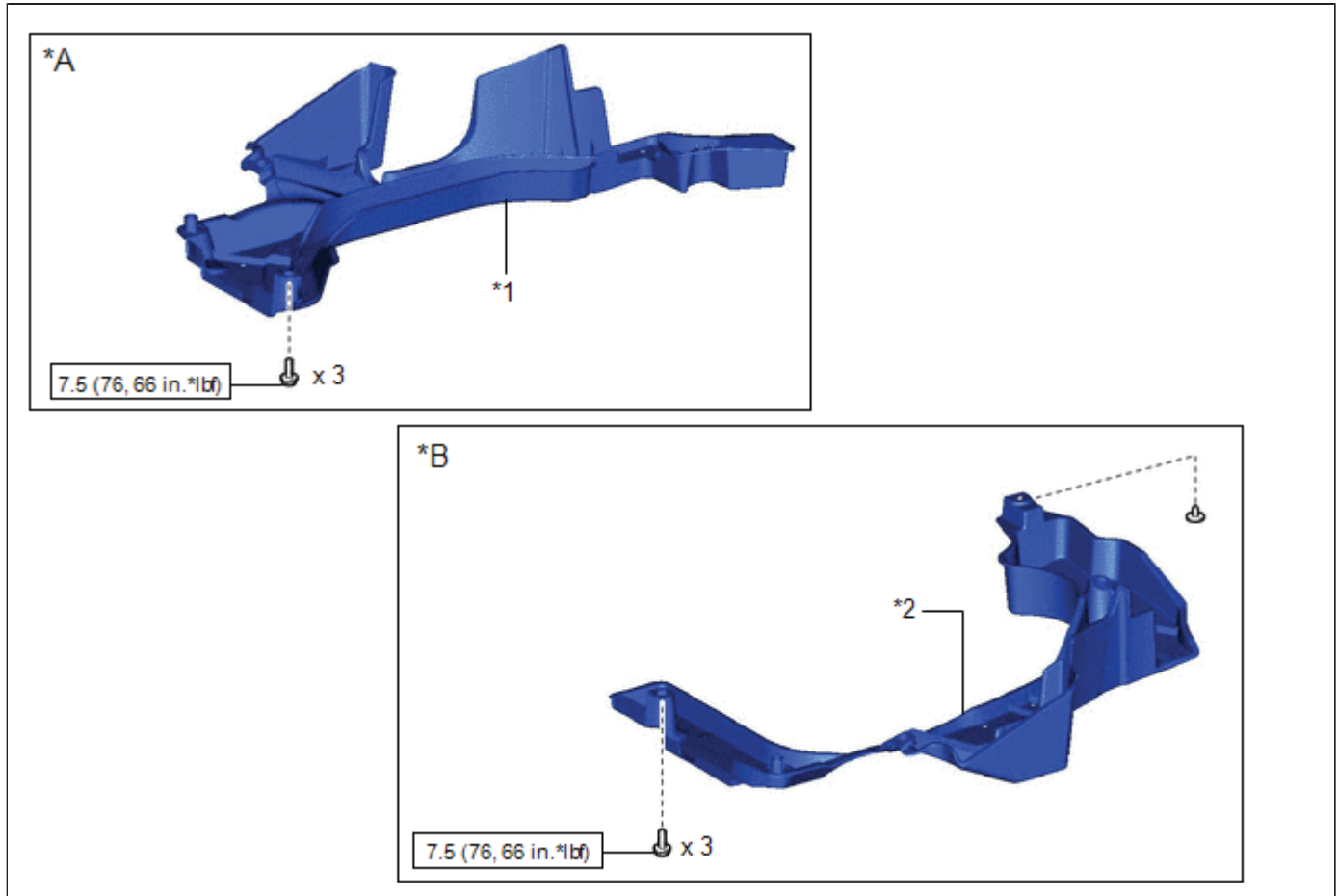

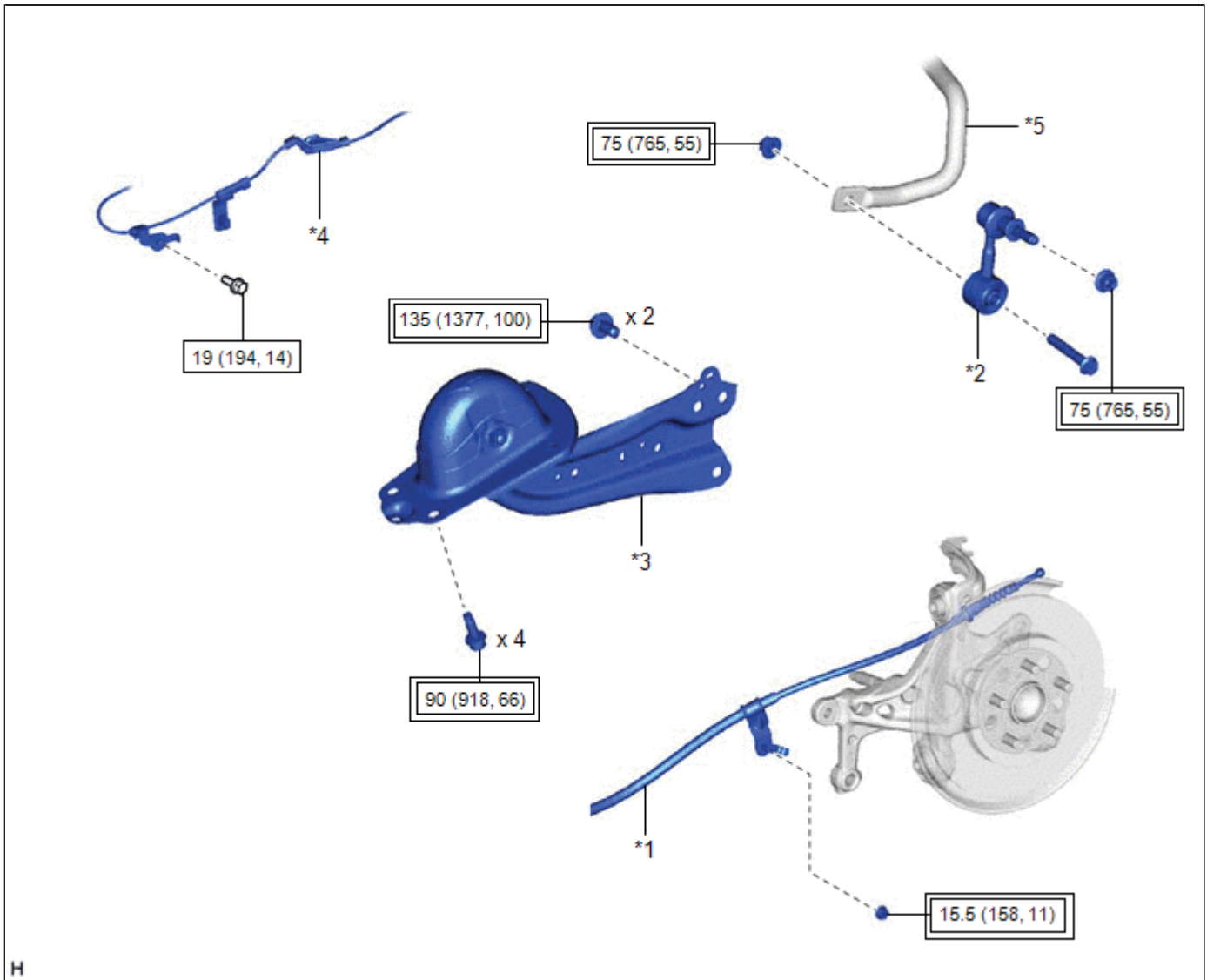

*A	for RH Side	*B	for LH Side
*1	NO. 1 FLOOR UNDER COVER ASSEMBLY	*2	REAR FLOOR SIDE MEMBER COVER LH
	N*m (kgf*cm, ft.*lbf): Specified torque	-	-

ILLUSTRATION



H

*1	NO. 3 PARKING BRAKE CABLE ASSEMBLY	*2	REAR STABILIZER LINK ASSEMBLY
*3	REAR TRAILING ARM ASSEMBLY	*4	SKID CONTROL SENSOR WIRE
*5	REAR STABILIZER BAR	-	-
	Tightening torque for "Major areas involving basic vehicle performance such as moving/turning/stopping" : N*m (kgf*cm, ft.*lbf)		N*m (kgf*cm, ft.*lbf): Specified torque

ILLUSTRATION

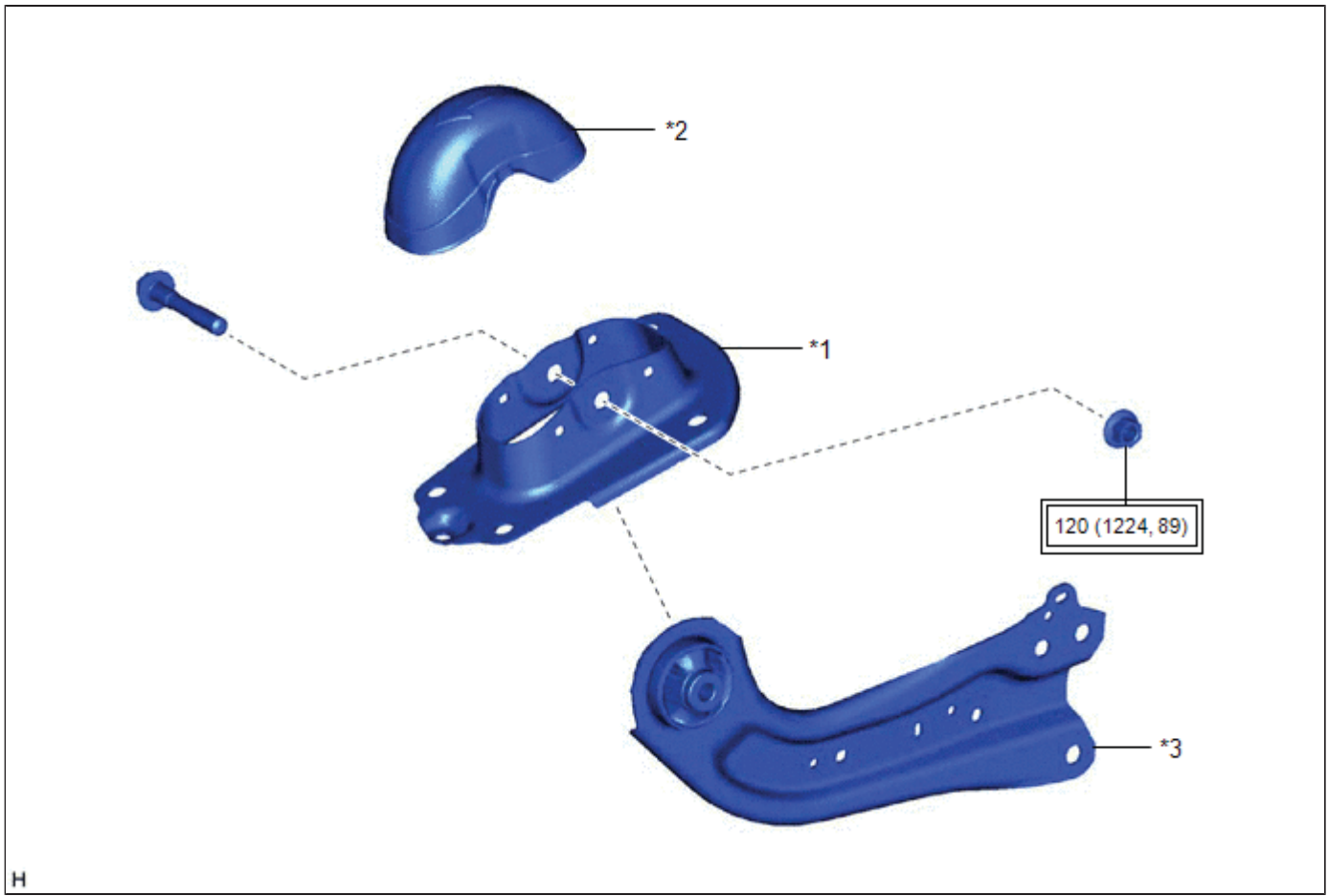

*1	REAR SUSPENSION ARM BRACKET	*2	REAR SUSPENSION ARM COVER
*3	REAR TRAILING ARM ASSEMBLY	-	-
	Tightening torque for "Major areas involving basic vehicle performance such as moving/turning/stopping" : N*m (kgf*cm, ft.*lbf)	-	-

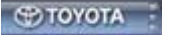

Last Modified: 01-14-2019	6.8:8.0.48	Doc ID: RM100000000RML6
Model Year Start: 2016	Model: Prius	Prod Date Range: [11/2015 - 12/2018]
Title: REAR SUSPENSION: REAR TRAILING ARM: INSTALLATION; 2016 - 2018 MY Prius [11/2015 - 12/2018]		

INSTALLATION

CAUTION / NOTICE / HINT

HINT:

- Use the same procedure for the RH side and LH side.
- The following procedure is for the LH side.

PROCEDURE

1. INSTALL REAR SUSPENSION ARM BRACKET

(a) Temporarily install the rear suspension arm bracket to the rear trailing arm assembly with the bolt and nut.

NOTICE:

- Because the bolt has its own stopper, do not turn the bolt. Tighten the nut with the bolt secured.
- Insert the bolt from the inside of the vehicle.

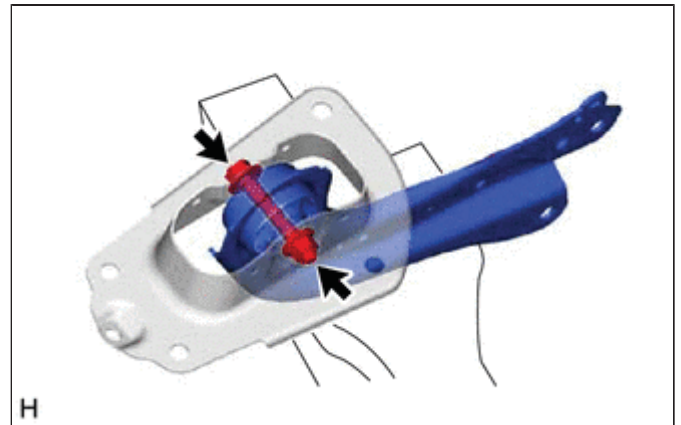

(b) Position the rear trailing arm assembly as shown in the illustration.

Reference Length (A):
116 mm (4.57 in.)

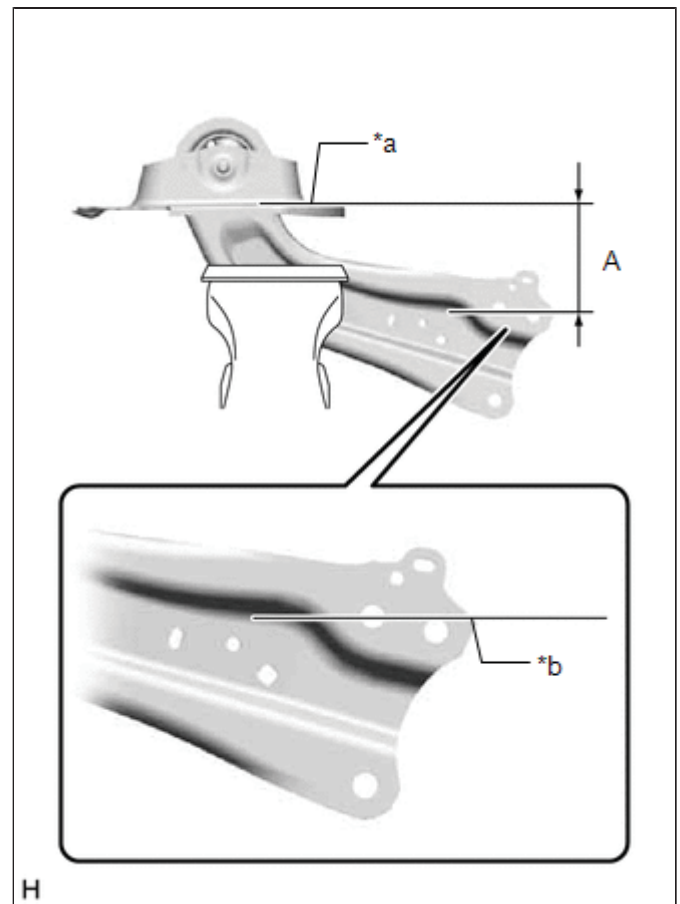

*a	Upper Surface of Rear Suspension Arm Bracket
*b	Edge of Rear Trailing Arm Assembly

(c) Fully tighten the nut.

Torque:

120 N·m { 1224 kgf·cm, 89 ft·lbf }

NOTICE:

Because the bolt has its own stopper, do not turn the bolt. Tighten the nut with the bolt secured.

2. INSTALL REAR SUSPENSION ARM COVER

(a) Engage the 4 claws and install the rear suspension arm cover.

3. INSTALL REAR TRAILING ARM ASSEMBLY

(a) Using a transmission jack and a wooden block, support the rear No. 2 suspension arm assembly.

NOTICE:

- When jacking up the rear No. 2 suspension arm assembly, be sure to jack it up slowly.
- Make sure to perform this operation with the vehicle kept as low as possible.

(b) Install the rear trailing arm assembly to the vehicle with the 4 bolts.

Torque:

90 N·m { 918 kgf·cm, 66 ft·lbf }

(c) Install the rear trailing arm assembly to the rear axle carrier sub-assembly with the 2 bolts.

Torque:

135 N·m { 1377 kgf·cm, 100 ft·lbf }

4. INSTALL SKID CONTROL SENSOR WIRE

(a) Install the skid control sensor wire to the rear trailing arm assembly with the bolt.

Torque:

19 N·m { 194 kgf·cm, 14 ft·lbf }

(b) Engage the 2 clamps.

5. INSTALL NO. 3 PARKING BRAKE CABLE ASSEMBLY

(a) Install the No. 3 parking brake cable assembly to the rear trailing arm assembly with the nut.

Torque:

15.5 N·m { 158 kgf·cm, 11 ft·lbf }

6. INSTALL REAR STABILIZER LINK ASSEMBLY

Click here [INFO](#)

7. INSTALL REAR FLOOR SIDE MEMBER COVER LH (for LH Side)

Click here [INFO](#)

8. INSTALL NO. 1 FLOOR UNDER COVER ASSEMBLY (for RH Side)

Click here [INFO](#)

9. INSTALL REAR WHEEL

Click here [INFO](#)

10. INSPECT AND ADJUST REAR WHEEL ALIGNMENT

Click here [INFO](#)

11. PERFORM INITIALIZATION

Intelligent clearance sonar system	INFO
Simple advanced parking guidance system	

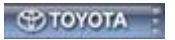

Last Modified: 01-14-2019	6.8:8.0.48	Doc ID: RM10000000RML8
Model Year Start: 2016	Model: Prius	Prod Date Range: [11/2015 - 12/2018]
Title: REAR SUSPENSION: REAR TRAILING ARM: REMOVAL; 2016 - 2018 MY Prius [11/2015 - 12/2018]		

REMOVAL

CAUTION / NOTICE / HINT

The necessary procedures (adjustment, calibration, initialization, or registration) that must be performed after parts are removed and installed, or replaced during rear trailing arm assembly removal/installation are shown below.

Necessary Procedures After Parts Removed/Installed/Replaced

REPLACED PART OR PERFORMED PROCEDURE	NECESSARY PROCEDURE	EFFECT/INOPERATIVE FUNCTION WHEN NECESSARY PROCEDURE NOT PERFORMED	LINK
Rear wheel alignment adjustment	<ol style="list-style-type: none"> 1. Clear zero point calibration data. 2. Perform yaw rate and acceleration sensor zero point calibration. 	<ul style="list-style-type: none"> • DTCs are stored • ABS warning light illuminates • Brake warning light/yellow (minor malfunction) illuminates • Slip indicator light illuminates • VSC disabled or malfunctions 	INFO
Suspension, tires, etc. (The vehicle height changes because of suspension or tire replacement)	<ul style="list-style-type: none"> • Ultrasonic sensor detection angle • Ultrasonic sensor detection angle registration 	<ul style="list-style-type: none"> • Intelligent clearance sonar system • Simple advanced parking guidance system 	INFO

HINT:

- Use the same procedure for the RH side and LH side.
- The following procedure is for the LH side.

PROCEDURE

1. REMOVE REAR WHEEL

Click here [INFO](#)

2. REMOVE REAR FLOOR SIDE MEMBER COVER LH (for LH Side)

Click here [INFO](#)

3. REMOVE NO. 1 FLOOR UNDER COVER ASSEMBLY (for RH Side)

Click here [INFO](#)

4. SEPARATE NO. 3 PARKING BRAKE CABLE ASSEMBLY

- (a) Remove the nut and separate the No. 3 parking brake cable assembly from the rear trailing arm assembly.

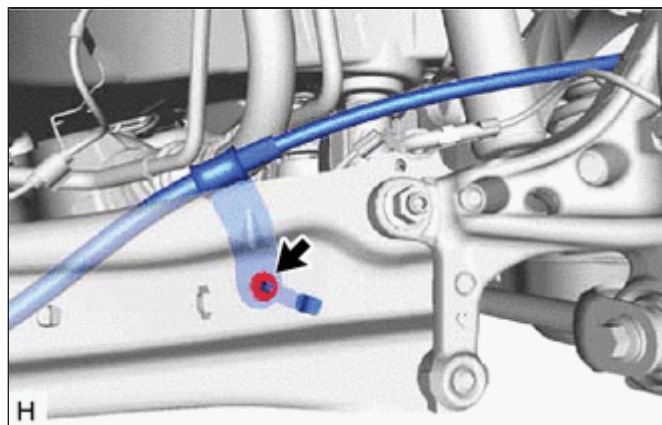

5. SEPARATE SKID CONTROL SENSOR WIRE

- (a) Disengage the 2 clamps.

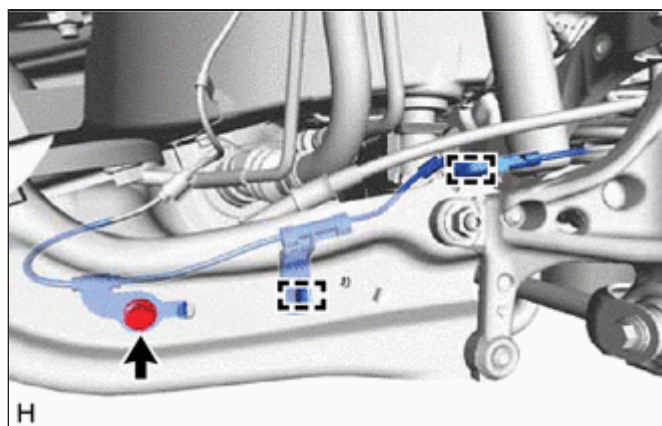

- (b) Remove the bolt and separate the skid control sensor wire from the rear trailing arm assembly.

6. REMOVE REAR STABILIZER LINK ASSEMBLY

Click here [INFO](#)

7. REMOVE REAR TRAILING ARM ASSEMBLY

- (a) Using a transmission jack and a wooden block, support the rear No. 2 suspension arm assembly.

NOTICE:

- When jacking up the rear No. 2 suspension arm assembly, be sure to jack it up slowly.
- Make sure to perform this operation with the vehicle kept as low as possible.

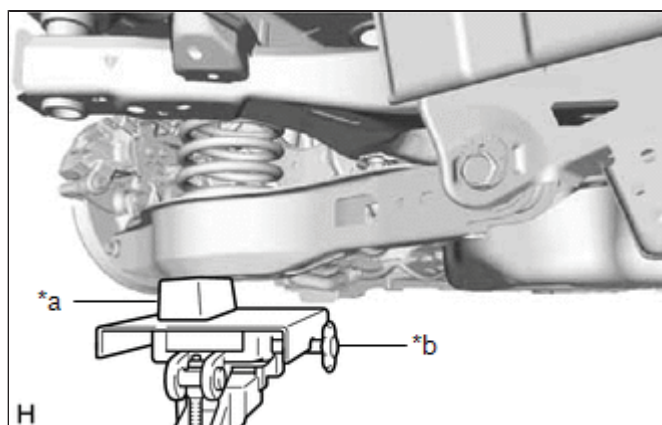

*a	Wooden Block
----	--------------

(b) Remove the 2 bolts and separate the rear trailing arm assembly from the rear axle carrier sub-assembly.

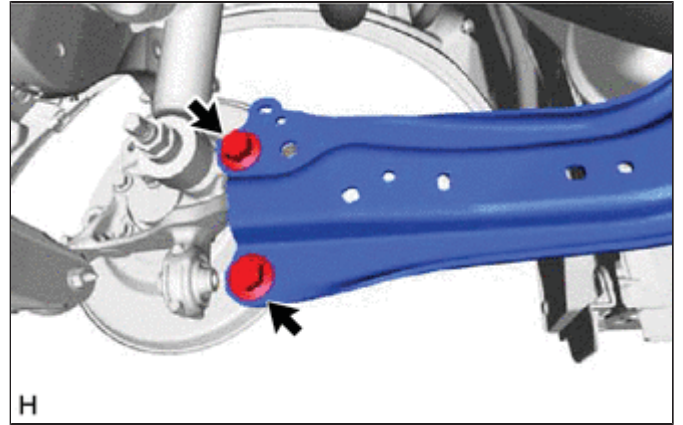

(c) Remove the 4 bolts and rear trailing arm assembly.

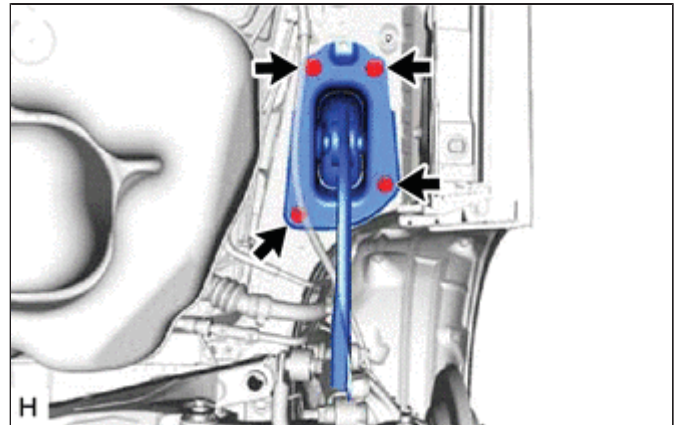

8. REMOVE REAR SUSPENSION ARM COVER

(a) Secure the rear trailing arm assembly in a vise using aluminum plates.

NOTICE:

Do not overtighten the vise.

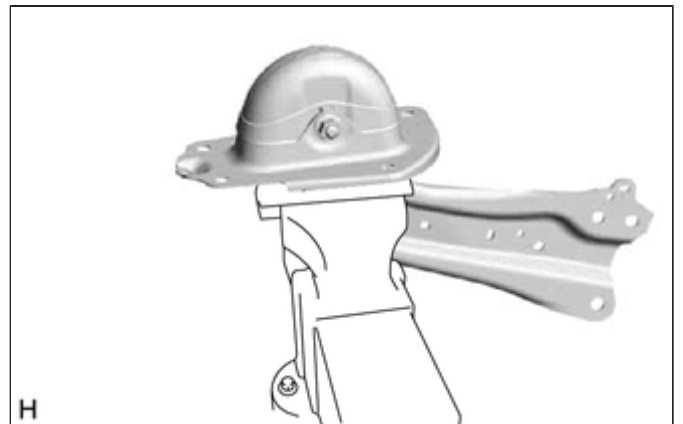

(b) Disengage the 4 claws and remove the rear suspension arm cover.



9. REMOVE REAR SUSPENSION ARM BRACKET

(a) Remove the bolt, nut and rear suspension arm bracket from the rear trailing arm assembly.

NOTICE:

Because the bolt has its own stopper, do not turn the bolt. Loosen the nut with the bolt secured.

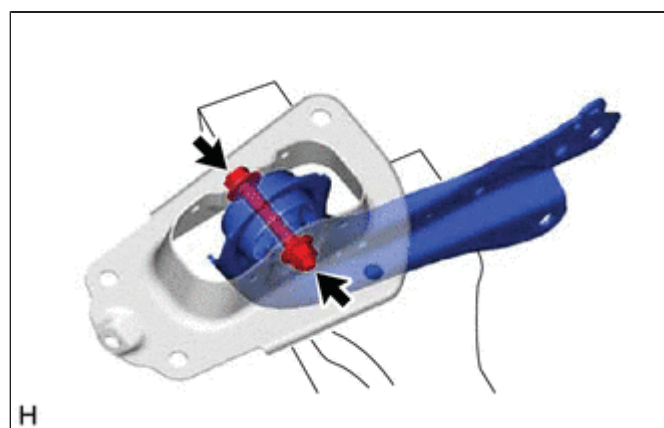

Last Modified: 01-14-2019	6.8:8.0.48	Doc ID: RM100000000RML1
Model Year Start: 2016	Model: Prius	Prod Date Range: [11/2015 - 12/2018]
Title: REAR SUSPENSION: REAR UPPER ARM: COMPONENTS; 2016 - 2018 MY Prius [11/2015 - 12/2018]		

COMPONENTS

ILLUSTRATION

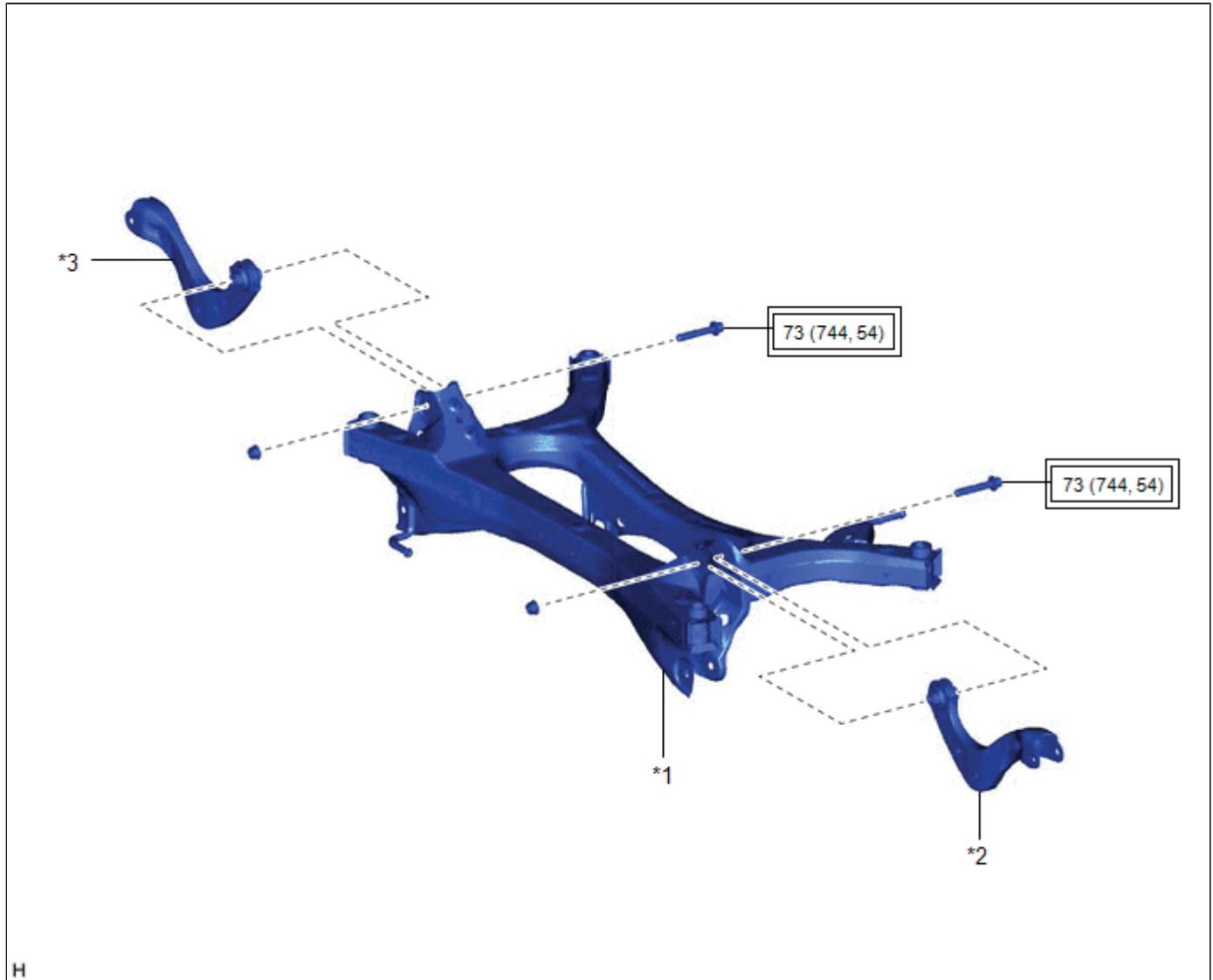

*1	REAR SUSPENSION MEMBER SUB-ASSEMBLY	*2	REAR UPPER CONTROL ARM ASSEMBLY LH
*3	REAR UPPER CONTROL ARM ASSEMBLY RH	-	-
	Tightening torque for "Major areas involving basic vehicle performance such as moving/turning/stopping" : N*m (kgf*cm, ft.*lbf)	-	-

Last Modified: 01-14-2019	6.8:8.0.48	Doc ID: RM100000000RML0
Model Year Start: 2016	Model: Prius	Prod Date Range: [11/2015 - 12/2018]
Title: REAR SUSPENSION: REAR UPPER ARM: INSTALLATION; 2016 - 2018 MY Prius [11/2015 - 12/2018]		

INSTALLATION

PROCEDURE

1. INSTALL REAR UPPER CONTROL ARM ASSEMBLY LH

- (a) Temporarily install the rear upper control arm assembly LH to the rear suspension member sub-assembly with the bolt and nut.

NOTICE:

- Because the nut has its own stopper, do not turn the nut. Tighten the bolt with the nut secured.
- Insert the bolt with the threaded end facing the front of the vehicle.

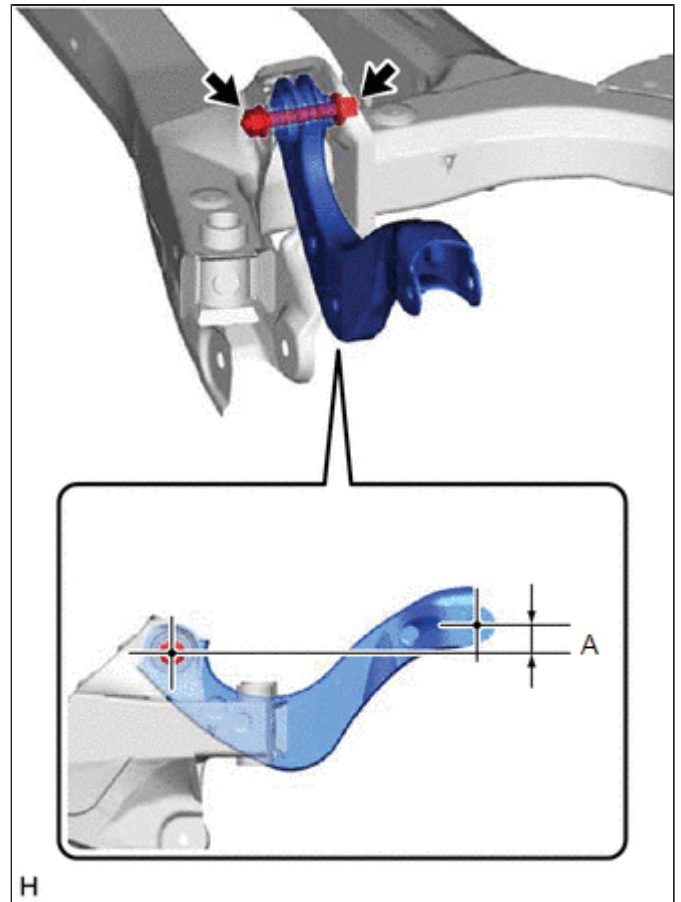

- (b) Position the rear upper control arm assembly LH as shown in the illustration.

Reference Length (A):

1.2 mm (0.0472 in.)

- (c) Fully tighten the bolt.

Torque:

73 N·m { 744 kgf·cm, 54 ft·lbf }

NOTICE:

Because the nut has its own stopper, do not turn the nut. Tighten the bolt with the nut secured.

2. INSTALL REAR UPPER CONTROL ARM ASSEMBLY RH

HINT:

Perform the same procedure as for the LH side.

3. INSTALL REAR SUSPENSION MEMBER SUB-ASSEMBLY

Click here [INFO](#)

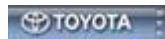

Last Modified: 01-14-2019	6.8:8.0.48	Doc ID: RM10000000RML2
Model Year Start: 2016	Model: Prius	Prod Date Range: [11/2015 - 12/2018]
Title: REAR SUSPENSION: REAR UPPER ARM: REMOVAL; 2016 - 2018 MY Prius [11/2015 - 12/2018]		

REMOVAL

CAUTION / NOTICE / HINT

The necessary procedures (adjustment, calibration, initialization, or registration) that must be performed after parts are removed and installed, or replaced during rear upper control arm assembly removal/installation are shown below.

Necessary Procedures After Parts Removed/Installed/Replaced

REPLACED PART OR PERFORMED PROCEDURE	NECESSARY PROCEDURE	EFFECT/INOPERATIVE FUNCTION WHEN NECESSARY PROCEDURE NOT PERFORMED	LINK
Rear wheel alignment adjustment	<ol style="list-style-type: none"> 1. Clear zero point calibration data. 2. Perform yaw rate and acceleration sensor zero point calibration. 	<ul style="list-style-type: none"> • DTCs are stored • ABS warning light illuminates • Brake warning light/yellow (minor malfunction) illuminates • Slip indicator light illuminates • VSC disabled or malfunctions 	INFO
Suspension, tires, etc. (The vehicle height changes because of suspension or tire replacement)	<ul style="list-style-type: none"> • Ultrasonic sensor detection angle • Ultrasonic sensor detection angle registration 	<ul style="list-style-type: none"> • Intelligent clearance sonar system • Simple advanced parking guidance system 	INFO
Gas leak from exhaust system is repaired	Inspection After Repair	<ul style="list-style-type: none"> • Poor idle, etc. • Engine start function, etc. 	INFO

CAUTION:

To prevent burns, do not touch the engine, exhaust pipe or other high temperature components while the engine is hot.



PROCEDURE

1. REMOVE REAR SUSPENSION MEMBER SUB-ASSEMBLY

Click here [INFO](#)

2. REMOVE REAR UPPER CONTROL ARM ASSEMBLY LH

- (a) Remove the bolt, nut and rear upper control arm assembly LH from the rear suspension member sub-assembly.

NOTICE:

Because the nut has its own stopper, do not turn the nut. Loosen the bolt with the nut secured.

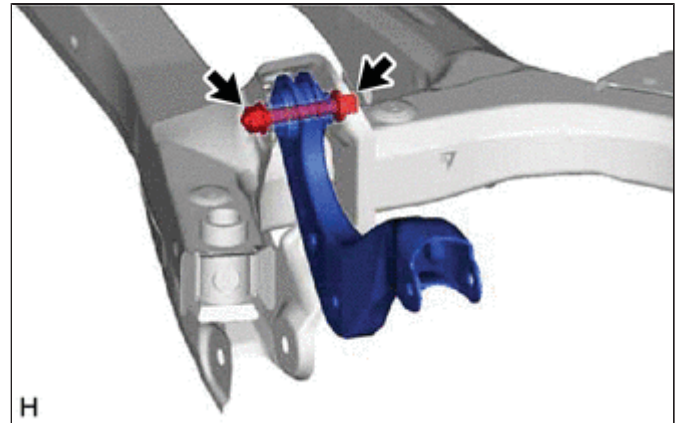

3. REMOVE REAR UPPER CONTROL ARM ASSEMBLY RH

HINT:

Perform the same procedure as for the LH side.

