

ROCKER OUTER PANEL (CUT-H)

REPLACEMENT

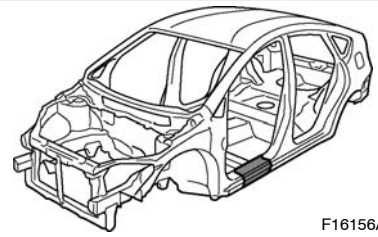

F16156A

REMOVAL

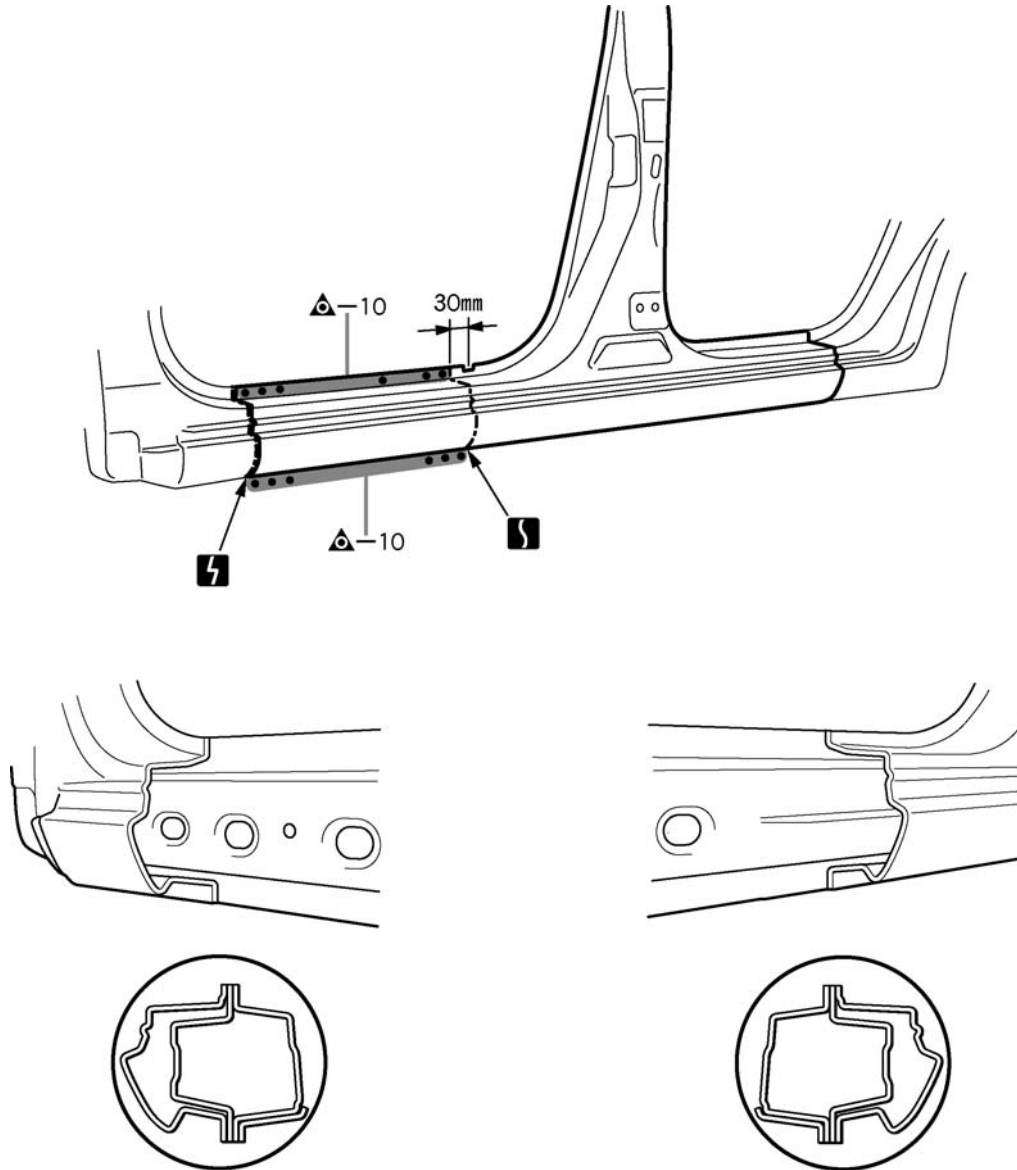

F16156

30mm (1.18in.)

INSTALLATION

- Temporarily install the new parts and measure each part of the new parts in accordance with the body dimension diagram. (See the body dimension diagram)
- Inspect the fitting of the related parts around the new parts before welding. This affects the appearance of the finish.
- After welding, apply the polyurethane foam to the corresponding parts.
- After welding, apply body sealer and under-coating to the corresponding parts.
- After applying the top coat layer, apply anti-rust agent to the inside of the necked section structural weld spots.

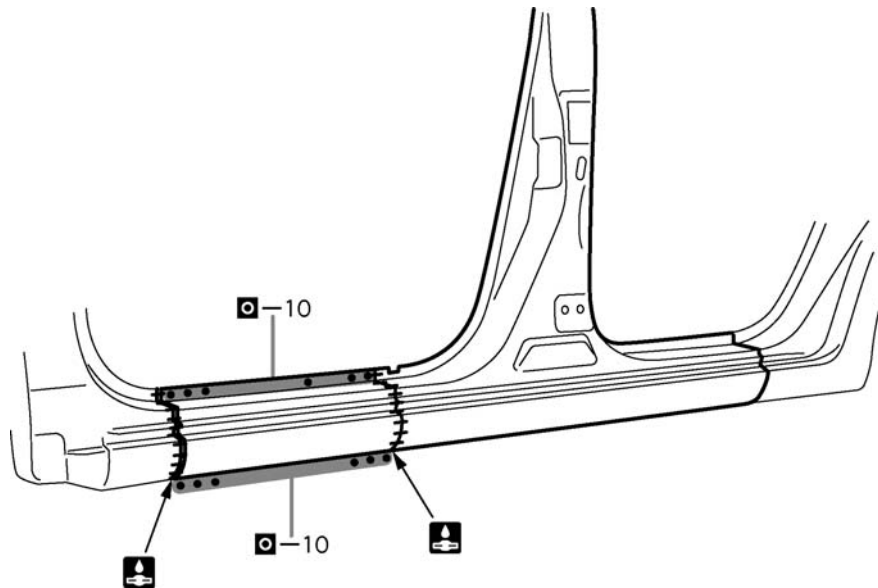

F16157

POINT

- 1 Inspect the fitting of the front door, etc., before welding, since this affects the appearance of the finish.