

| | | |
|--|--------------|--------------------------------------|
| Last Modified: 01-14-2019 | 6.8:8.0.48 | Doc ID: RM100000000TC4H |
| Model Year Start: 2016 | Model: Prius | Prod Date Range: [11/2015 - 08/2016] |
| Title: 2ZR-FXE (COOLING): COOLANT (for Engine): REPLACEMENT; 2016 MY Prius [11/2015 - 08/2016] | | |

REPLACEMENT

CAUTION / NOTICE / HINT

CAUTION:

Do not remove the reserve tank cap, air release valve (w/ air release valve) or radiator drain cock plug while the engine and radiator assembly are still hot. Pressurized, hot engine coolant and steam may be released and cause serious burns.

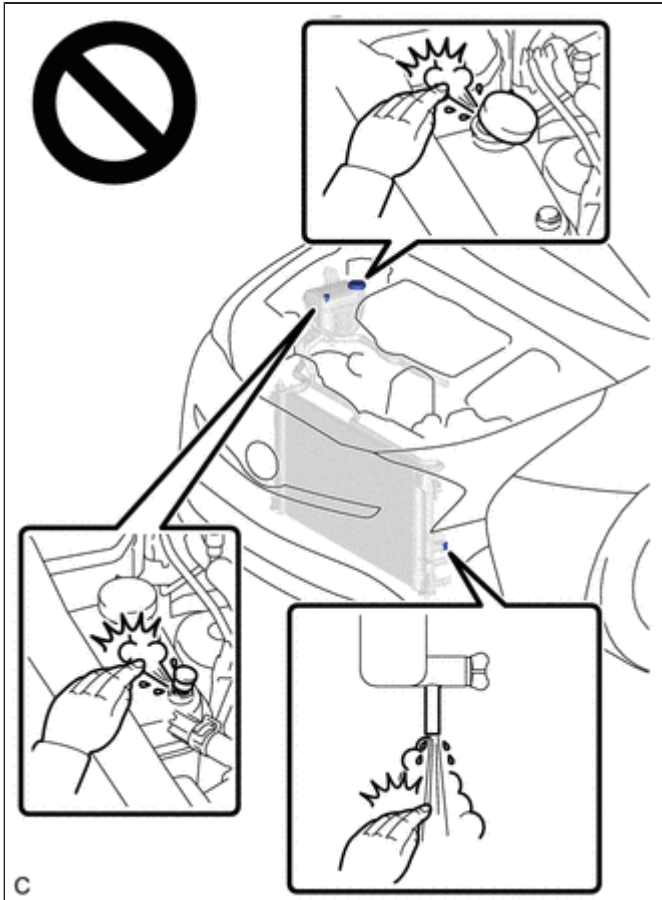

PROCEDURE

1. REMOVE REAR MOTOR UNDER COVER LH

Click here [INFO](#)

2. DRAIN ENGINE COOLANT (for Engine)

CAUTION:

Do not remove the reserve tank cap, air release valve (w/ air release valve) or radiator drain cock plug while the engine and radiator assembly are still hot. Pressurized, hot engine coolant and steam may be released and cause serious burns.

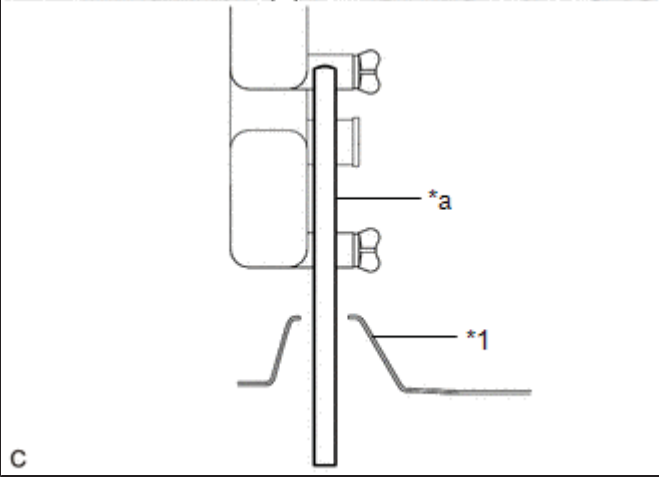
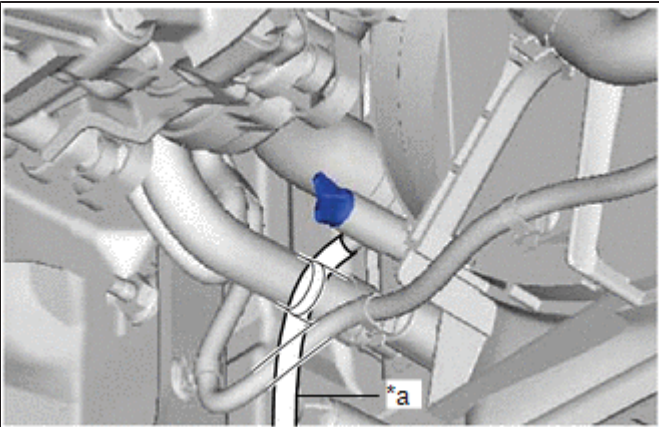

c

| | |
|----|--------------------------|
| *1 | No. 1 Engine Under Cover |
| *a | Hose |

(a) Connect a hose with an inside diameter of 9 mm (0.354 in.) to the radiator drain cock as shown in the illustration.

(b) Loosen the radiator drain cock plug.

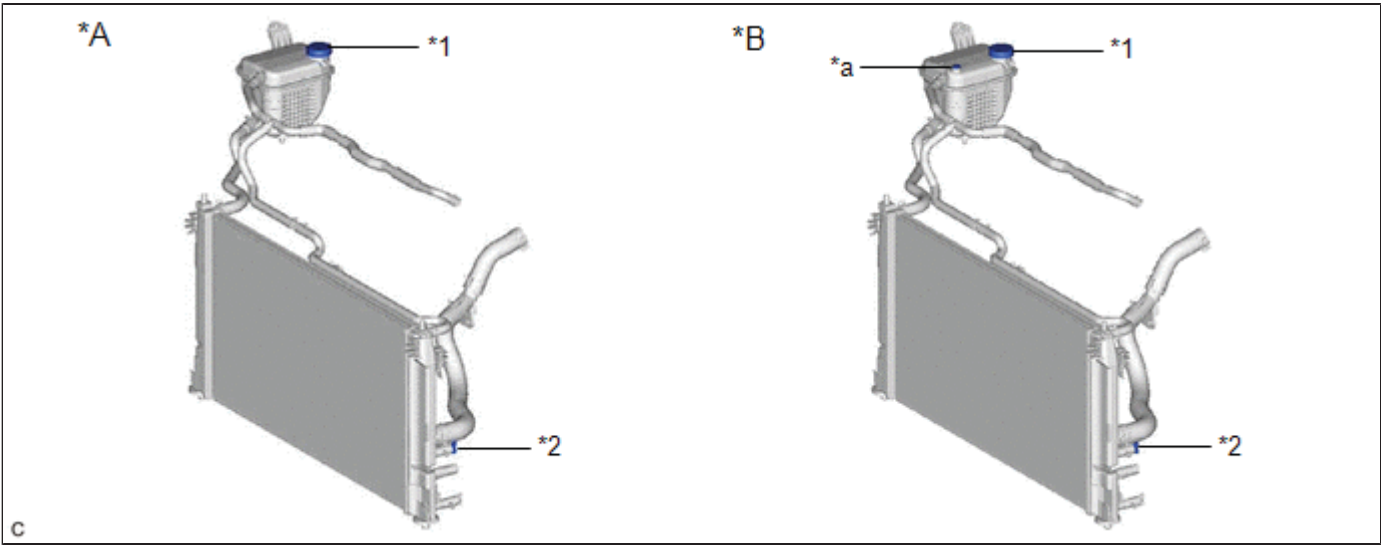

c

| | | | |
|----|-----------------------|----|--------------------------|
| *A | w/o Air Release Valve | *B | w/ Air Release Valve |
| *1 | Reserve Tank Cap | *2 | Radiator Drain Cock Plug |
| *a | Air Release Valve | - | - |

(c) Remove the reserve tank cap. Then drain the engine coolant.

HINT:

Collect the engine coolant in a container and dispose of it according to the regulations in your area.

- (d) Tighten the radiator drain cock plug by hand.
- (e) Disconnect the hose from the radiator drain cock.

3. ADD ENGINE COOLANT (for Engine)

(a) w/ Air Release Valve:

(1) Using a 6 mm hexagon socket wrench, remove the air release valve from the radiator reserve tank assembly.

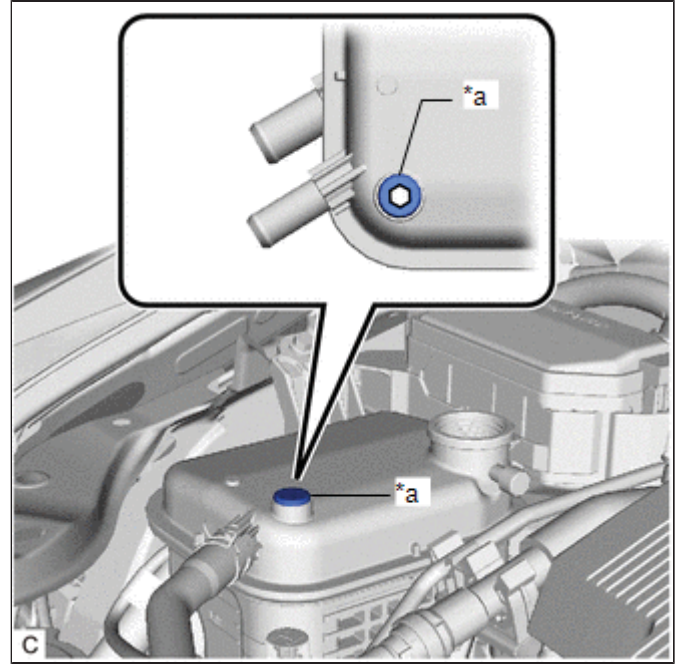

| | |
|----|-------------------|
| *a | Air Release Valve |
|----|-------------------|

(b) Add coolant to the level shown in the illustration.

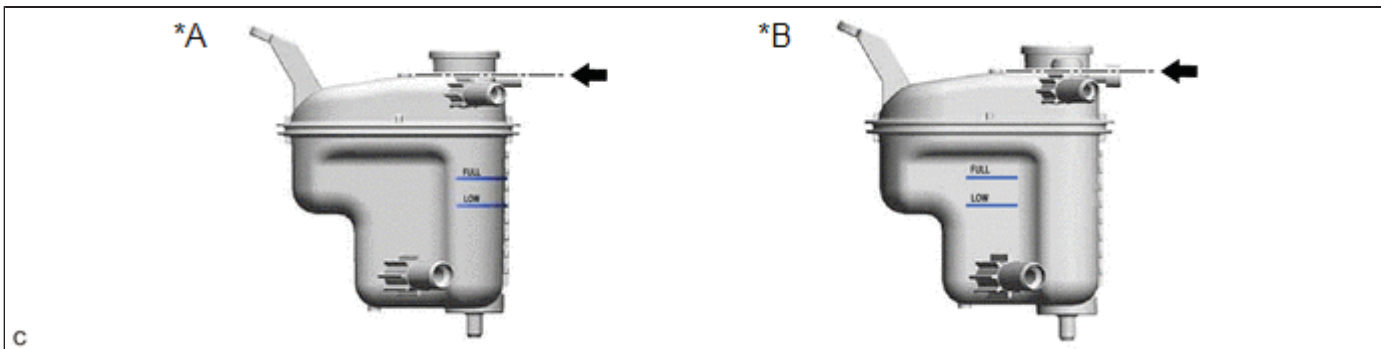

| | | | |
|----|-----------------------|----|----------------------|
| *A | w/o Air Release Valve | *B | w/ Air Release Valve |
|----|-----------------------|----|----------------------|

Specified Capacity:

| | |
|---------------------------------------|---------------------------------------|
| w/ Exhaust Heat Recirculation System | 6.0 liters (6.3 US qts, 5.3 Imp. qts) |
| w/o Exhaust Heat Recirculation System | 5.4 liters (5.7 US qts, 4.8 Imp. qts) |

NOTICE:

Do not substitute plain water for engine coolant.

HINT:

TOYOTA vehicles are filled with TOYOTA SLLC at the factory. In order to avoid damaging the engine cooling system and other technical problems, only use TOYOTA SLLC or similar high quality ethylene glycol based non-silicate, non-amine, non-nitrite, non-borate coolant with long-life hybrid organic acid technology (coolant with long-life hybrid organic acid technology is a combination of low phosphates and organic acids).

- (c) Squeeze the No. 1 radiator hose and No. 2 radiator hose several times by hand, and then check the level of the engine coolant.

If the engine coolant level is low, add engine coolant.

- (d) w/ Air Release Valve:

(1) Using a 6 mm hexagon socket wrench, install the air release valve to the radiator reserve tank assembly.

Torque:

2.0 N·m {20 kgf·cm, 18 in·lbf}

- (e) Install the reserve tank cap.

NOTICE:

Securely tighten the reserve tank cap as much as possible.

- (f) Put the engine in inspection mode (maintenance mode).

Click here 

- (g) Bleed air from the cooling system.

NOTICE:

- Before starting the engine, turn the A/C switch off.
- Adjust the heater control to the maximum hot setting.
- Adjust the blower speed to the low setting.

(1) Warm up the engine until the water inlet with thermostat sub-assembly opens. While the water inlet with thermostat sub-assembly is open, circulate the engine coolant for several minutes.

HINT:

The water inlet with thermostat sub-assembly open timing can be confirmed by squeezing the No. 2 radiator hose by hand, and sensing vibrations when the engine coolant starts to flow inside the No. 2 radiator hose.

(2) Squeeze the No. 1 radiator hose and No. 2 radiator hose several times by hand to bleed air from the system.

When squeezing the No. 1 radiator hose and No. 2 radiator hose:

- Wear protective gloves.
- Be careful as the No. 1 radiator hose and No. 2 radiator hose are hot.
- Keep your hands away from the fan LH and fan RH.

NOTICE:

- Make sure that the radiator reserve tank assembly still has some engine coolant in it.
- If the coolant temperature gauge indicates an excessive temperature, turn off the engine and let it cool.
- If there is not enough engine coolant, the engine may overheat or be seriously damaged.
- If the radiator reserve tank assembly does not have enough engine coolant, perform the following: 1) stop the engine, 2) wait until the engine coolant has cooled down, and 3) add engine coolant until the radiator reserve tank assembly is filled to the FULL line.

- (h) After the engine has cooled down, check that the engine coolant level is between the FULL line and LOW line.

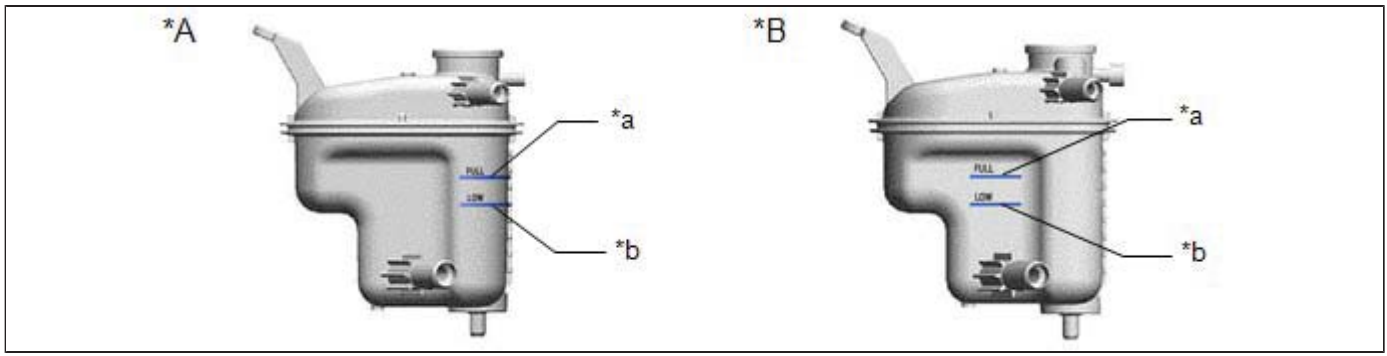

| | | | |
|----|-----------------------|----|----------------------|
| *A | w/o Air Release Valve | *B | w/ Air Release Valve |
| *a | FULL Line | *b | LOW Line |

NOTICE:

The coolant levels in the compartments inside the radiator reserve tank assembly may differ, but this is not a malfunction.

If the engine coolant level is below the LOW line, add engine coolant to the FULL line.

4. INSPECT FOR COOLANT LEAK (for Engine)

Click here [INFO](#)

5. INSTALL REAR MOTOR UNDER COVER LH

Click here [INFO](#)

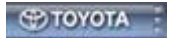

| | | |
|--|--------------|-------------------------------|
| Last Modified: 01-14-2019 | 6.8:8.0.48 | Doc ID: RM100000000TC4P |
| Model Year Start: 2016 | Model: Prius | Prod Date Range: [11/2015 -] |
| Title: 2ZR-FXE (COOLING): COOLING FAN MOTOR: COMPONENTS; 2016 - 2019 MY Prius [11/2015 -] | | |

COMPONENTS

ILLUSTRATION

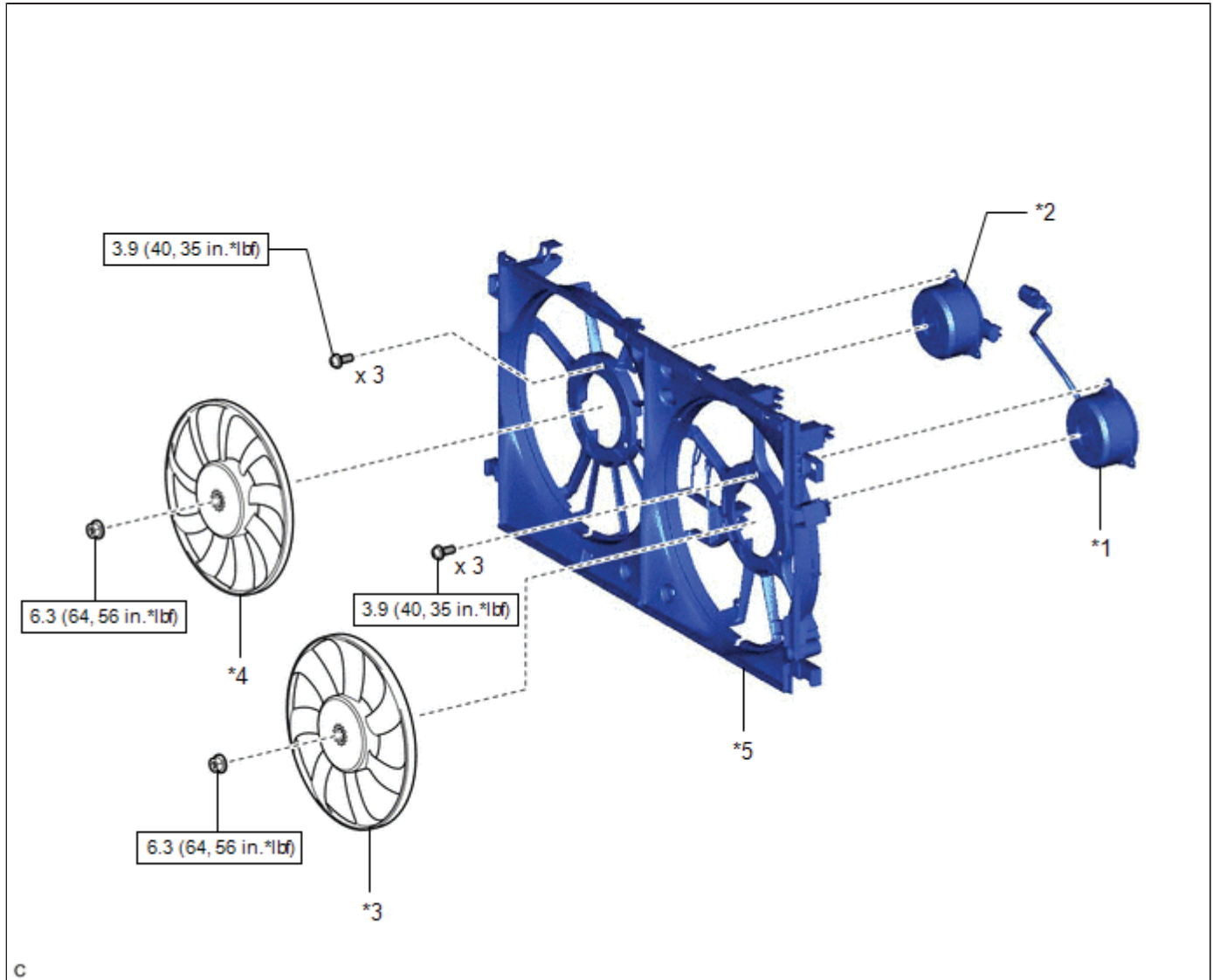

| | | | |
|---|---|----|----------------------|
| *1 | COOLING FAN MOTOR LH | *2 | COOLING FAN MOTOR RH |
| *3 | FAN LH | *4 | FAN RH |
| *5 | FAN SHROUD | - | - |
|  | N*m (kgf*cm, ft.*lbf): Specified torque | - | - |

| | | |
|---|---------------------|--------------------------------------|
| Last Modified: 01-14-2019 | 6.8:8.0.48 | Doc ID: RM100000000TC4S |
| Model Year Start: 2016 | Model: Prius | Prod Date Range: [11/2015 -] |
| Title: 2ZR-FXE (COOLING): COOLING FAN MOTOR: INSTALLATION; 2016 - 2019 MY Prius [11/2015 -] | | |

INSTALLATION

PROCEDURE

1. INSTALL COOLING FAN MOTOR LH

(a) Install the cooling fan motor LH with the 3 screws.

Torque:

3.9 N·m { 40 kgf·cm, 35 in·lbf }

(b) Engage the 3 clamps.

2. INSTALL COOLING FAN MOTOR RH

(a) Install the cooling fan motor RH with the 3 screws.

Torque:

3.9 N·m { 40 kgf·cm, 35 in·lbf }

3. INSTALL FAN LH

NOTICE:

Do not reverse the position of the fan LH and fan RH when installing them. Doing so may damage the parts.

(a) Install the fan LH with the nut.

Torque:

6.3 N·m { 64 kgf·cm, 56 in·lbf }

4. INSTALL FAN RH

NOTICE:

Do not reverse the position of the fan LH and fan RH when installing them. Doing so may damage the parts.

(a) Install the fan RH with the nut.

Torque:

6.3 N·m { 64 kgf·cm, 56 in·lbf }

5. INSTALL RADIATOR ASSEMBLY

Click here 

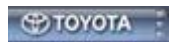

| | | |
|---|--------------|-------------------------------|
| Last Modified: 01-14-2019 | 6.8:8.0.48 | Doc ID: RM100000000TC4Q |
| Model Year Start: 2016 | Model: Prius | Prod Date Range: [11/2015 -] |
| Title: 2ZR-FXE (COOLING): COOLING FAN MOTOR: ON-VEHICLE INSPECTION; 2016 - 2019 MY Prius [11/2015 -] | | |

ON-VEHICLE INSPECTION

CAUTION / NOTICE / HINT

CAUTION:

To prevent injury due to contact with an operating cooling fan, keep your hands and clothing away from the cooling fans when inspecting the cooling fan system.

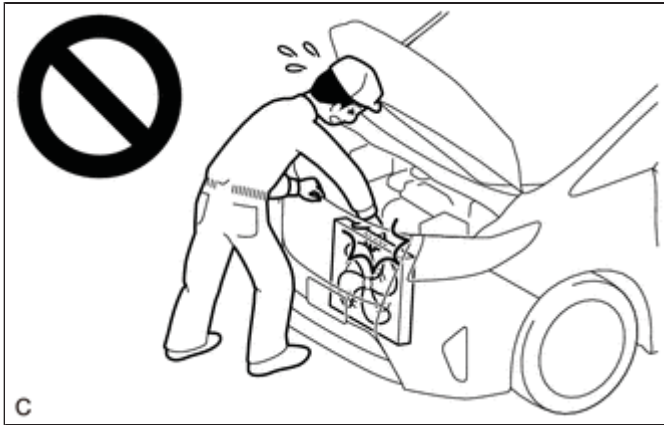

PROCEDURE

1. INSPECT COOLING FAN MOTOR LH

CAUTION:

To prevent injury due to contact with an operating cooling fan, keep your hands and clothing away from the cooling fans when inspecting the cooling fan system.

- (a) Disconnect the cooling fan motor LH connector.

- (b) Check that the cooling fan motor LH operates smoothly when the auxiliary battery is connected to the cooling fan motor LH connector.

OK:



[Click Location & Routing\(A6\)](#)

[Click Connector\(A6\)](#)

| TESTER CONNECTION | SPECIFIED CONDITION |
|--|-----------------------|
| A6-2 - Auxiliary battery positive (+) A6-1 - Auxiliary battery positive (-) | Operation is smoothly |

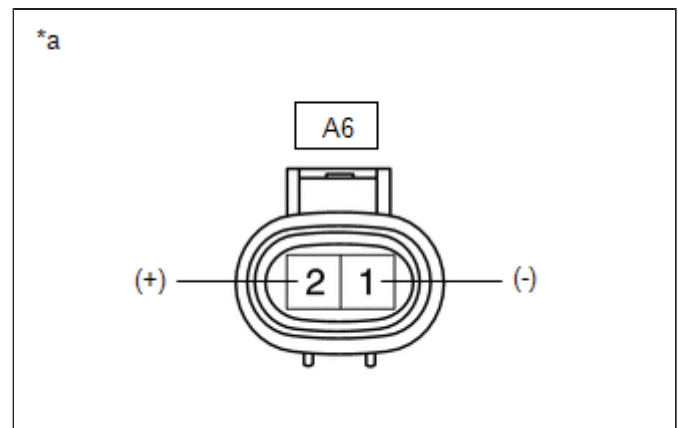

| | |
|----|--|
| *a | Component without harness connected (Cooling Fan Motor LH) |
|----|--|

(c) Measure the current while the cooling fan motor LH is operating.

Standard Current:

| CONDITION | SPECIFIED CONDITION |
|--|---------------------|
| Auxiliary battery voltage applied at 20°C (68°F) | 7.4 to 10.9 A |

If the result is not as specified, replace the cooling fan motor LH.

(d) Connect the cooling fan motor LH connector.

2. INSPECT COOLING FAN MOTOR RH

CAUTION:

To prevent injury due to contact with an operating cooling fan, keep your hands and clothing away from the cooling fans when inspecting the cooling fan system.

(a) Disconnect the cooling fan motor RH connector.

(b) Check that the cooling fan motor RH operates smoothly when the auxiliary battery is connected to the cooling fan motor RH connector.

OK:



[Click Location & Routing\(A5\)](#)

[Click Connector\(A5\)](#)

| TESTER CONNECTION | SPECIFIED CONDITION |
|--|-----------------------|
| A5-2 - Auxiliary battery positive (+) A5-1 - Auxiliary battery positive (-) | Operation is smoothly |

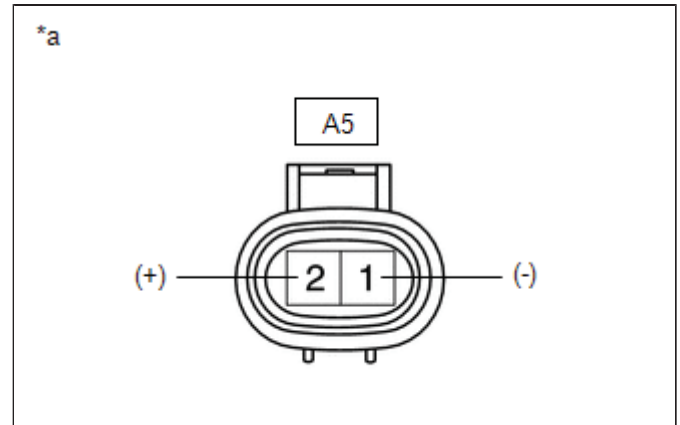

| | |
|----|--|
| *a | Component without harness connected (Cooling Fan Motor RH) |
|----|--|

(c) Measure the current while the cooling fan motor RH is operating.

Standard Current:

| CONDITION | SPECIFIED CONDITION |
|--|---------------------|
| Auxiliary battery voltage applied at 20°C (68°F) | 7.4 to 10.9 A |

If the result is not as specified, replace the cooling fan motor RH.

(d) Connect the cooling fan motor RH connector.

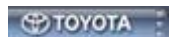

| | | |
|--|---------------------|--------------------------------------|
| Last Modified: 01-14-2019 | 6.8:8.0.48 | Doc ID: RM100000000TC4R |
| Model Year Start: 2016 | Model: Prius | Prod Date Range: [11/2015 -] |
| Title: 2ZR-FXE (COOLING): COOLING FAN MOTOR: REMOVAL; 2016 - 2019 MY Prius [11/2015 -] | | |

REMOVAL

CAUTION / NOTICE / HINT

The necessary procedures (adjustment, calibration, initialization, or registration) that must be performed after parts are removed and installed, or replaced during cooling fan motor LH or cooling fan motor RH removal/installation are shown below.

Necessary Procedure After Parts Removed/Installed/Replaced

| REPLACED PART OR PERFORMED PROCEDURE | NECESSARY PROCEDURE | EFFECT/INOPERATIVE FUNCTION WHEN NECESSARY PROCEDURE NOT PERFORMED | LINK |
|--------------------------------------|---|---|--|
| Front bumper assembly | <ul style="list-style-type: none"> • Ultrasonic sensor detection angle (w/ Intuitive Parking Assist System) • Ultrasonic sensor detection angle registration (w/ Intuitive Parking Assist System) | <ul style="list-style-type: none"> • Intelligent clearance sonar system • Simple advanced parking guidance system | INFO INFO |
| | Change grille shutter control mode and/or perform initialization | Grille Shutter system | INFO |

PROCEDURE

1. REMOVE RADIATOR ASSEMBLY

Click here [INFO](#)

2. REMOVE FAN RH

(a) Remove the nut and fan RH.

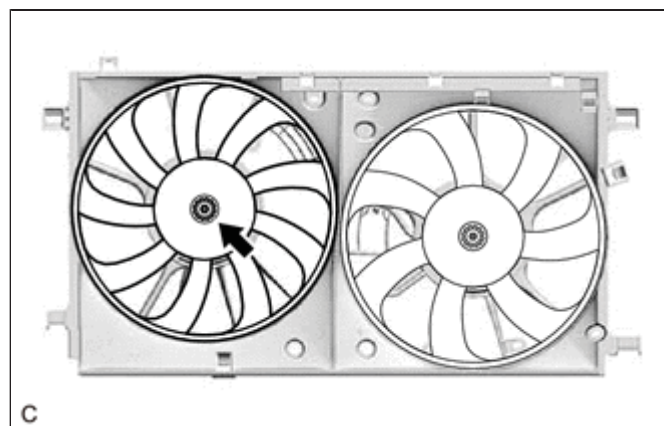

3. REMOVE FAN LH

(a) Remove the nut and fan LH.

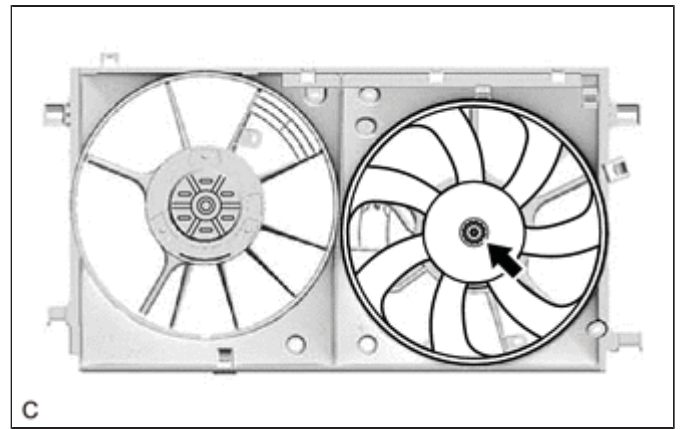

4. REMOVE COOLING FAN MOTOR RH

(a) Remove the 3 screws and cooling fan motor RH.

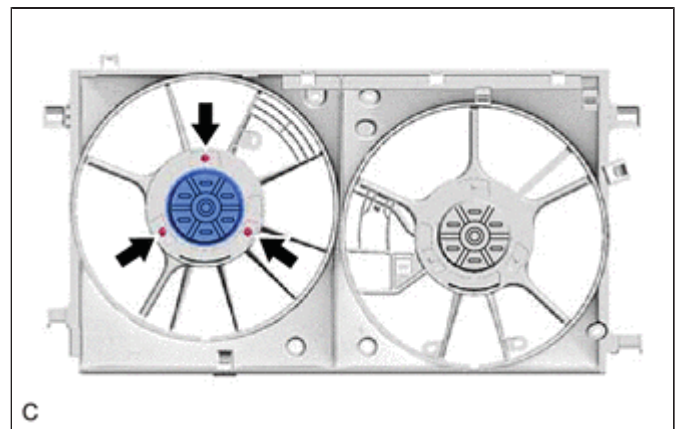

5. REMOVE COOLING FAN MOTOR LH

(a) Disengage the 3 clamps.

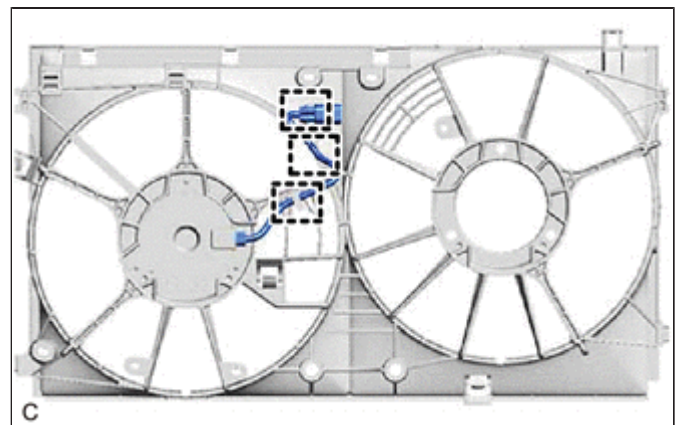

(b) Remove the 3 screws and cooling fan motor LH.

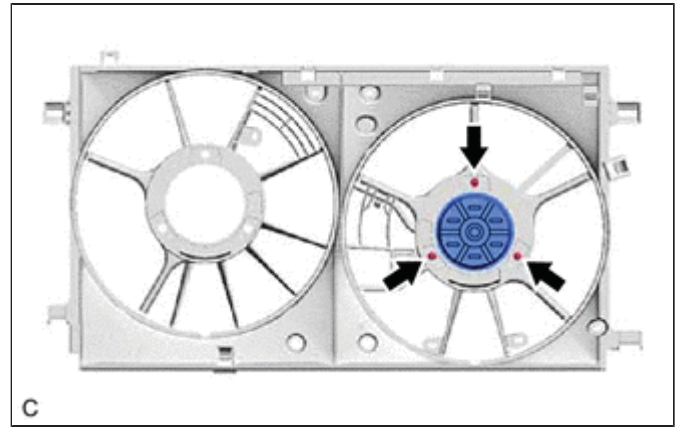

| | | |
|---|---------------------|--------------------------------------|
| Last Modified: 01-14-2019 | 6.8:8.0.48 | Doc ID: RM100000000U3H4 |
| Model Year Start: 2016 | Model: Prius | Prod Date Range: [11/2015 -] |
| Title: 2ZR-FXE (COOLING): COOLING FAN SYSTEM: Cooling Fan Circuit; 2016 - 2019 MY Prius [11/2015 -] | | |

Cooling Fan Circuit

DESCRIPTION

The ECM turns on or off the fan relays using signals calculated from the engine coolant temperature, air conditioning switch (on/off), air conditioning refrigerant pressure, engine speed and vehicle speed signals.

The ECM switches the circuit of the cooling fan motors between series and parallel by turning on or off the fan relays in order to control the speed of the cooling fan motors in two steps.

WIRING DIAGRAM

Refer to the System Diagram.

Click here [INFO](#)

CAUTION / NOTICE / HINT

NOTICE:

- Inspect the fuses for circuits related to this system before performing the following procedure.
- Before replacing the ECM, refer to Registration.

Click here [INFO](#) [INFO](#)

PROCEDURE

1. PERFORM ACTIVE TEST USING TECHSTREAM (CONTROL THE ENGINE COOLING FAN)

- Connect the Techstream to the DLC3.
- Turn the power switch on (IG).
- Turn the Techstream on.
- Enter the following menus: Powertrain / Engine / Active Test / Control the Engine Cooling Fan

Powertrain > Engine > Active Test

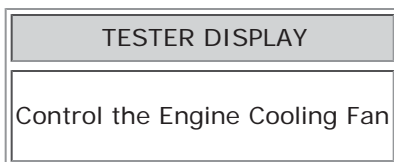

- Perform the Active Test according to the display on the Techstream.

OK:

ACTIVE TESTER OPERATION

FAN OPERATION

| | |
|------|---------------------------------|
| High | Cooling fans high speed operate |
| Low | Cooling fans low speed operate |
| OFF | Cooling fans stop |

OK ▶ **PROCEED TO NEXT SUSPECTED AREA SHOWN IN PROBLEM SYMPTOMS TABLE**

NG
▼

| | |
|-----------|---|
| 2. | CHECK HARNESS AND CONNECTOR (FANL - FANH POWER SOURCE) |
|-----------|---|

- (a) Disconnect the A40 ECM connector.
- (b) Turn the power switch on (IG).
- (c) Measure the voltage according to the value(s) in the table below.

Standard Voltage:



[Click Location & Routing\(A40\)](#)

[Click Connector\(A40\)](#)

| TESTER CONNECTION | CONDITION | SPECIFIED CONDITION |
|----------------------------|----------------------|---------------------|
| A40-8 (FANH) - Body ground | Power switch on (IG) | 11 to 14 V |
| A40-7 (FANL) - Body ground | Power switch on (IG) | 11 to 14 V |

NG ▶ **GO TO STEP 12**

OK
▼

| | |
|-----------|---|
| 3. | CHECK HARNESS AND CONNECTOR (FAN NO. 1 RELAY AND FAN NO. 3 RELAY POWER SOURCE CIRCUIT) |
|-----------|---|

- (a) Remove the FAN NO. 1 relay and FAN NO. 3 relay from the No. 2 relay block.

(b) Measure the voltage according to the value(s) in the table below.

Standard Voltage:

| TESTER CONNECTION | CONDITION | SPECIFIED CONDITION |
|-----------------------------------|-----------|---------------------|
| 3 (FAN NO. 1 relay) - Body ground | Always | 11 to 14 V |
| 3 (FAN NO. 3 relay) - Body ground | Always | 11 to 14 V |

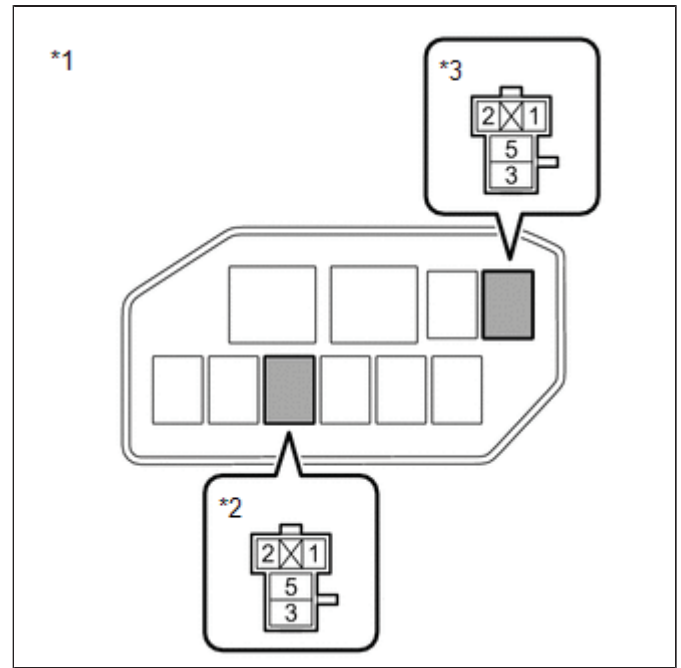

| | |
|----|-------------------|
| *1 | No. 2 Relay Block |
| *2 | FAN NO. 1 Relay |
| *3 | FAN NO. 3 Relay |

NG ► REPAIR OR REPLACE HARNESS OR CONNECTOR (FAN NO. 1 RELAY AND FAN NO. 3 RELAY POWER SOURCE CIRCUIT)

OK



4. INSPECT COOLING FAN RELAY (FAN NO. 1, FAN NO. 2 AND FAN NO. 3)

(a) Inspect the FAN NO. 1 relay, FAN NO. 2 relay and FAN NO. 3 relay.

Click here [INFO](#)

| RESULT | PROCEED TO |
|----------------------|------------|
| OK | A |
| NG (FAN NO. 1 relay) | B |
| NG (FAN NO. 2 relay) | C |
| NG (FAN NO. 3 relay) | D |

B ▶ REPLACE FAN NO. 1 RELAY

C ▶ REPLACE FAN NO. 2 RELAY

D ▶ REPLACE FAN NO. 3 RELAY

A
▼

5. CHECK HARNESS AND CONNECTOR (FAN NO. 2 RELAY - BODY GROUND)

(a) Remove the FAN NO. 2 relay from the No. 2 relay block.

(b) Measure the resistance according to the value(s) in the table below.

Standard Resistance (Check for Open):

| TESTER CONNECTION | CONDITION | SPECIFIED CONDITION |
|-----------------------------------|-----------|---------------------|
| 5 (FAN NO. 2 relay) - Body ground | Always | Below 1 Ω |

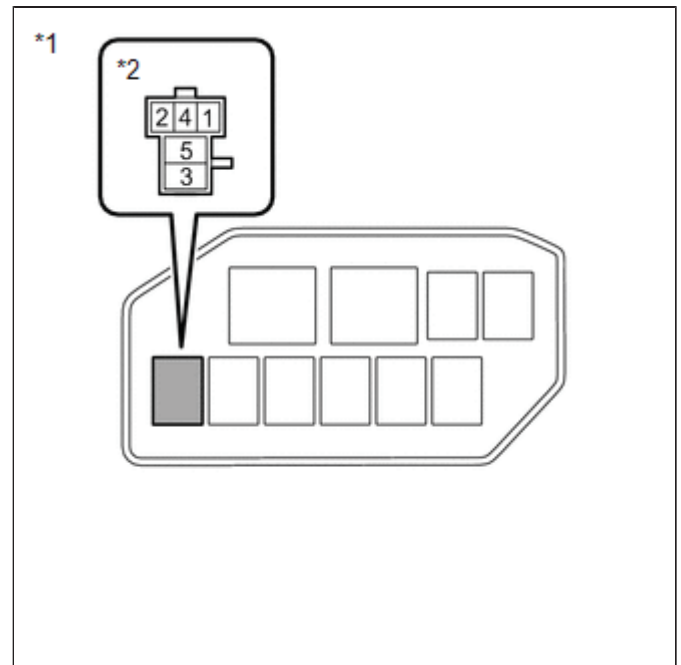

| | |
|----|-------------------|
| *1 | No. 2 Relay Block |
| *2 | FAN NO. 2 Relay |

NG ▶ REPAIR OR REPLACE HARNESS OR CONNECTOR (FAN NO. 2 RELAY - BODY GROUND)

OK
▼

6. INSPECT COOLING FAN MOTOR RH

(a) Inspect the cooling fan motor RH.

Click here 

NG  REPLACE COOLING FAN MOTOR RH

OK

7. CHECK HARNESS AND CONNECTOR (COOLING FAN MOTOR RH - BODY GROUND)

- (a) Disconnect the A5 cooling fan motor RH connector.
- (b) Measure the resistance according to the value(s) in the table below.

Standard Resistance (Check for Open):

 **EWD INFO**

[Click Location & Routing\(A5\)](#)
[Click Connector\(A5\)](#)

| TESTER CONNECTION | CONDITION | SPECIFIED CONDITION |
|--------------------|-----------|---------------------|
| A5-1 - Body ground | Always | Below 1 Ω |

NG  REPAIR OR REPLACE HARNESS OR CONNECTOR (COOLING FAN MOTOR RH - BODY GROUND)

OK

8. CHECK HARNESS AND CONNECTOR (FAN NO. 1 RELAY AND FAN NO. 2 RELAY - COOLING FAN MOTOR RH)

- (a) Disconnect the A5 cooling fan motor RH connector.
- (b) Remove the FAN NO. 1 relay and FAN NO. 2 relay from the No. 2 relay block.
- (c) Measure the resistance according to the value(s) in the table below.

Standard Resistance (Check for Open):

EWD INFO

[Click Location & Routing\(A5\)](#)

[Click Connector\(A5\)](#)

| TESTER CONNECTION | CONDITION | SPECIFIED CONDITION |
|----------------------------|-----------|---------------------|
| A5-2 - 5 (FAN NO. 1 relay) | Always | Below 1 Ω |
| A5-2 - 4 (FAN NO. 2 relay) | Always | Below 1 Ω |

Standard Resistance (Check for Short):

EWD INFO

[Click Location & Routing\(A5\)](#)

[Click Connector\(A5\)](#)

| TESTER CONNECTION | CONDITION | SPECIFIED CONDITION |
|---|-----------|-------------------------|
| A5-2 or 5 (FAN NO. 1 relay) - Body ground | Always | 10 k Ω or higher |
| A5-2 or 4 (FAN NO. 2 relay) - Body ground | Always | 10 k Ω or higher |

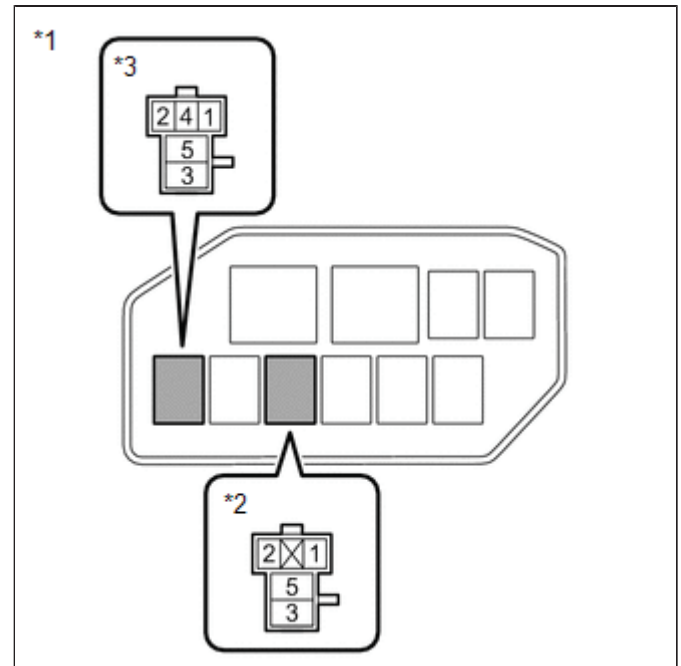

| | |
|----|-------------------|
| *1 | No. 2 Relay Block |
| *2 | FAN NO. 1 Relay |
| *3 | FAN NO. 2 Relay |

NG  **REPAIR OR REPLACE HARNESS OR CONNECTOR (FAN NO. 1 RELAY AND FAN NO. 2 RELAY - COOLING FAN MOTOR RH)**

OK



9. INSPECT COOLING FAN MOTOR LH

(a) Inspect the cooling fan motor LH.

Click here 

NG  **REPLACE COOLING FAN MOTOR LH**

OK



CHECK HARNESS AND CONNECTOR (FAN NO. 2 RELAY AND FAN NO. 3 RELAY - COOLING FAN)

10. MOTOR LH)

- (a) Disconnect the A6 cooling fan motor LH connector.
- (b) Remove the FAN NO. 2 relay and FAN NO. 3 relay from the No. 2 relay block.
- (c) Measure the resistance according to the value(s) in the table below.

Standard Resistance (Check for Open):



[Click Location & Routing\(A6\)](#)

[Click Connector\(A6\)](#)

| TESTER CONNECTION | CONDITION | SPECIFIED CONDITION |
|----------------------------|-----------|---------------------|
| A6-1 - 3 (FAN NO. 2 relay) | Always | Below 1 Ω |
| A6-2 - 5 (FAN NO. 3 relay) | Always | Below 1 Ω |

Standard Resistance (Check for Short):



[Click Location & Routing\(A6\)](#)

[Click Connector\(A6\)](#)

| TESTER CONNECTION | CONDITION | SPECIFIED CONDITION |
|---|-----------|---------------------|
| A6-1 or 3 (FAN NO. 2 relay) - Body ground | Always | 10 kΩ or higher |
| A6-2 or 5 (FAN NO. 3 relay) - Body ground | Always | 10 kΩ or higher |

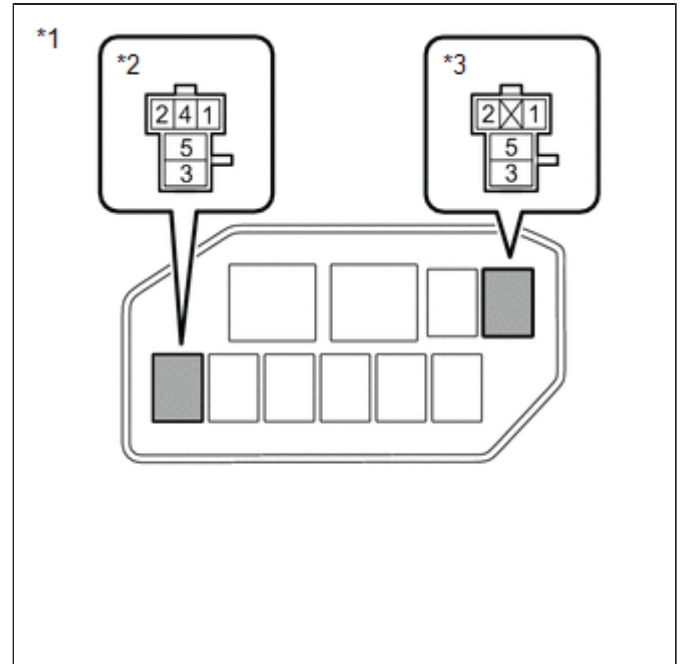

| | |
|----|-------------------|
| *1 | No. 2 Relay Block |
| *2 | FAN NO. 2 Relay |
| *3 | FAN NO. 3 Relay |

NG ▶ REPAIR OR REPLACE HARNESS OR CONNECTOR (FAN NO. 2 RELAY AND FAN NO. 3 RELAY - COOLING FAN MOTOR LH)

OK



11. CHECK HARNESS AND CONNECTOR (FAN NO. 1 RELAY - FAN NO. 2 RELAY)

- (a) Remove the FAN NO. 1 relay and FAN NO. 2 relay from the No. 2 relay block.

(b) Measure the resistance according to the value(s) in the table below.

Standard Resistance (Check for Open):

| TESTER CONNECTION | CONDITION | SPECIFIED CONDITION |
|---|-----------|---------------------|
| 1 (FAN NO. 1 relay) - 2 (FAN NO. 2 relay) | Always | Below 1 Ω |
| 2 (FAN NO. 1 relay) - 1 (FAN NO. 2 relay) | Always | Below 1 Ω |

Standard Resistance (Check for Short):

| TESTER CONNECTION | CONDITION | SPECIFIED CONDITION |
|--|-----------|-------------------------|
| 1 (FAN NO. 1 relay) or 2 (FAN NO. 2 relay) - Body ground | Always | 10 k Ω or higher |
| 2 (FAN NO. 1 relay) or 1 (FAN NO. 2 relay) - Body ground | Always | 10 k Ω or higher |

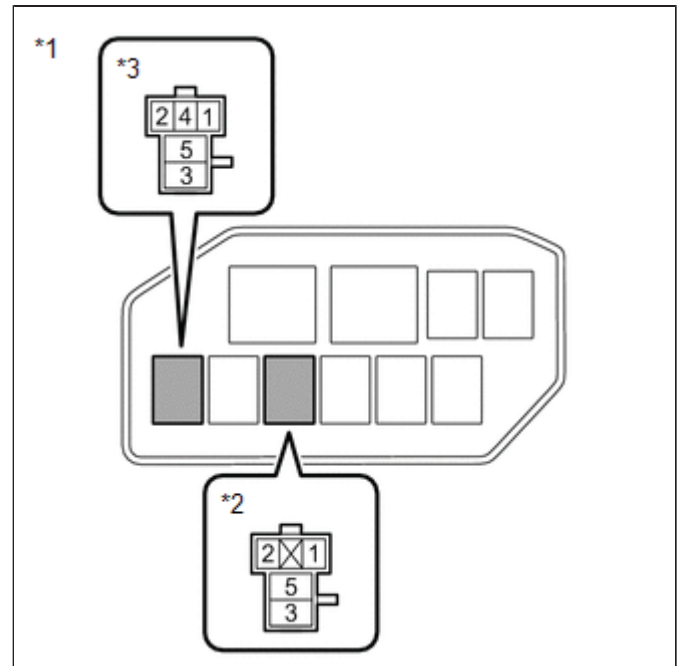

| | |
|----|-------------------|
| *1 | No. 2 Relay Block |
| *2 | FAN NO. 1 Relay |
| *3 | FAN NO. 2 Relay |

OK REPLACE ECM

NG REPAIR OR REPLACE NO. 2 RELAY BLOCK

12. INSPECT COOLING FAN RELAY (FAN NO. 1, FAN NO. 2 AND FAN NO. 3)

(a) Inspect the FAN NO. 1 relay, FAN NO. 2 relay and FAN NO. 3 relay.

Click here

| RESULT | PROCEED TO |
|----------------------|------------|
| OK | A |
| NG (FAN NO. 1 relay) | B |
| NG (FAN NO. 2 relay) | C |
| NG (FAN NO. 3 relay) | D |

B REPLACE FAN NO. 1 RELAY

C ▶ REPLACE FAN NO. 2 RELAY

D ▶ REPLACE FAN NO. 3 RELAY

A
▼

| | |
|------------|--|
| 13. | CHECK HARNESS AND CONNECTOR (FAN NO. 1 RELAY, FAN NO. 2 RELAY AND FAN NO. 3 RELAY POWER SOURCE CIRCUIT) |
|------------|--|

(a) Remove the FAN NO. 1 relay, FAN NO. 2 relay and FAN NO. 3 relay from the No. 2 relay block.

(b) Measure the voltage according to the value(s) in the table below.

Standard Voltage:

| TESTER CONNECTION | CONDITION | SPECIFIED CONDITION |
|-----------------------------------|-----------|---------------------|
| 1 (FAN NO. 1 relay) - Body ground | Always | 11 to 14 V |
| 2 (FAN NO. 2 relay) - Body ground | Always | 11 to 14 V |
| 1 (FAN NO. 3 relay) - Body ground | Always | 11 to 14 V |

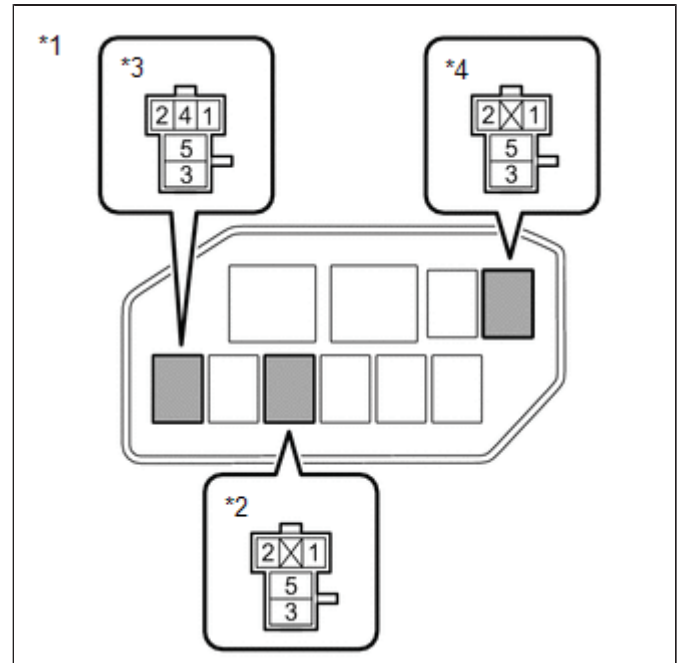

| | |
|----|-------------------|
| *1 | No. 2 Relay Block |
| *2 | FAN NO. 1 Relay |
| *3 | FAN NO. 2 Relay |
| *4 | FAN NO. 3 Relay |

OK ▶ REPAIR OR REPLACE HARNESS OR CONNECTOR (FAN NO. 1 RELAY, FAN NO. 2 RELAY AND FAN NO. 3 RELAY - ECM)

NG
▼

14.

CHECK HARNESS AND CONNECTOR (FAN NO. 1 RELAY, FAN NO. 2 RELAY AND FAN NO. 3 RELAY - NO. 1 INTEGRATION RELAY)

- (a) Remove the FAN NO. 1 relay, FAN NO. 2 relay and FAN NO. 3 relay from the No. 2 relay block.
- (b) Remove the No. 1 integration relay from the No. 1 engine room relay block and No. 1 junction block assembly.
- (c) Disconnect the 1B No. 1 integration relay connector.

(d) Measure the resistance according to the value(s) in the table below.

Standard Resistance (Check for Open):

| TESTER CONNECTION | CONDITION | SPECIFIED CONDITION |
|----------------------------|-----------|---------------------|
| 1 (FAN NO. 1 relay) - 1B-4 | Always | Below 1 Ω |
| 2 (FAN NO. 2 relay) - 1B-4 | Always | Below 1 Ω |
| 1 (FAN NO. 3 relay) - 1B-4 | Always | Below 1 Ω |

Standard Resistance (Check for Short):

| TESTER CONNECTION | CONDITION | SPECIFIED CONDITION |
|---|-----------|---------------------|
| 1 (FAN NO. 1 relay) or 1B-4 - Body ground | Always | 10 kΩ or higher |
| 2 (FAN NO. 2 relay) or 1B-4 - Body ground | Always | 10 kΩ or higher |
| 1 (FAN NO. 3 relay) or 1B-4 - Body ground | Always | 10 kΩ or higher |

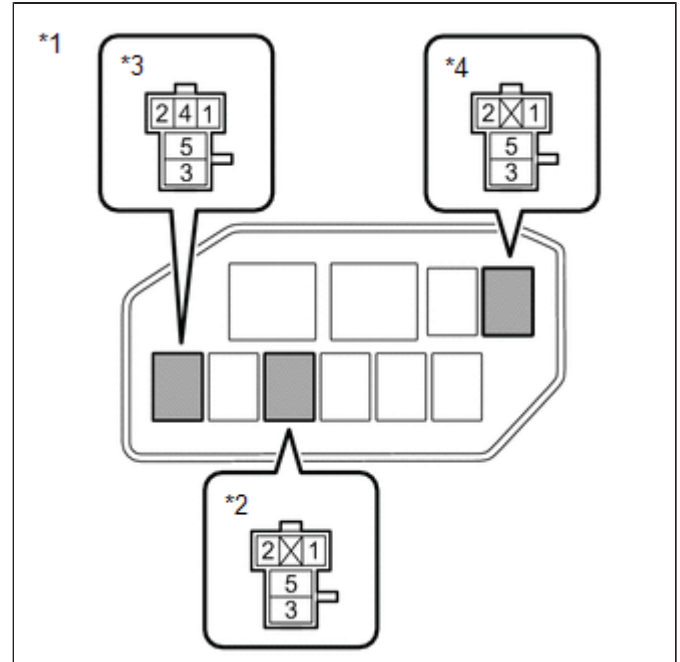

| | |
|----|-------------------|
| *1 | No. 2 Relay Block |
| *2 | FAN NO. 1 Relay |
| *3 | FAN NO. 2 Relay |
| *4 | FAN NO. 3 Relay |

NG ▶ **REPAIR OR REPLACE HARNESS OR CONNECTOR (FAN NO. 1 RELAY, FAN NO. 2 RELAY AND FAN NO. 3 RELAY - NO. 1 INTEGRATION RELAY)**

OK



15.

INSPECT NO. 1 INTEGRATION RELAY (EFI-MAIN RELAY)

- (a) Inspect the No. 1 integration relay.

NG ▶ REPAIR OR REPLACE NO. 1 INTEGRATION RELAY (EFI-MAIN RELAY)

OK
▼

16. CHECK HARNESS AND CONNECTOR (NO. 1 INTEGRATION RELAY POWER SOURCE CIRCUIT)

- (a) Remove the No. 1 integration relay from the No. 1 engine room relay block and No. 1 junction block assembly.
- (b) Disconnect the 1B No. 1 integration relay connector.

(c) Measure the voltage according to the value(s) in the table below.

Standard Voltage:

| TESTER CONNECTION | CONDITION | SPECIFIED CONDITION |
|--------------------|-----------|---------------------|
| 1B-3 - Body ground | Always | 11 to 14 V |

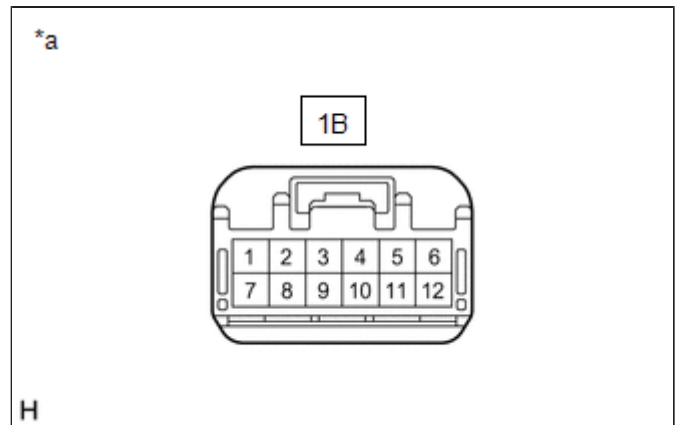

*a Front view of wire harness connector (to No. 1 Integration Relay)

NG ▶ REPAIR OR REPLACE HARNESS OR CONNECTOR (NO. 1 INTEGRATION RELAY POWER SOURCE CIRCUIT)

OK
▼

17. CHECK HARNESS AND CONNECTOR (NO. 1 INTEGRATION RELAY - BODY GROUND)

- (a) Remove the No. 1 integration relay from the No. 1 engine room relay block and No. 1 junction block assembly.
- (b) Disconnect the 1B No. 1 integration relay connector.
- (c) Measure the resistance according to the value(s) in the table below.

Standard Resistance:

| TESTER CONNECTION | CONDITION | SPECIFIED CONDITION |
|--------------------|-----------|---------------------|
| 1B-5 - Body ground | Always | Below 1 Ω |

NG ▶ REPAIR OR REPLACE HARNESS OR CONNECTOR (NO. 1 INTEGRATION RELAY - BODY GROUND)

OK



18. CHECK HARNESS AND CONNECTOR (ECM - NO. 1 INTEGRATION RELAY)

- (a) Disconnect the A40 ECM connector.
- (b) Remove the No. 1 integration relay from the No. 1 engine room relay block and No. 1 junction block assembly.
- (c) Disconnect the 1B No. 1 integration relay connector.
- (d) Measure the resistance according to the value(s) in the table below.

Standard Resistance (Check for Open):



[Click Location & Routing\(A40\)](#)

[Click Connector\(A40\)](#)

| TESTER CONNECTION | CONDITION | SPECIFIED CONDITION |
|----------------------|-----------|---------------------|
| A40-46 (MREL) - 1B-6 | Always | Below 1 Ω |

Standard Resistance (Check for Short):



[Click Location & Routing\(A40\)](#)

[Click Connector\(A40\)](#)

| TESTER CONNECTION | CONDITION | SPECIFIED CONDITION |
|-------------------------------------|-----------|-------------------------|
| A40-46 (MREL) or 1B-6 - Body ground | Always | 10 k Ω or higher |

OK ▶ REPLACE ECM [INFO](#) [INFO](#)

NG ▶ REPAIR OR REPLACE HARNESS OR CONNECTOR (ECM - NO. 1 INTEGRATION RELAY)

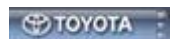

| | | |
|--|--------------|-------------------------------|
| Last Modified: 01-14-2019 | 6.8:8.0.48 | Doc ID: RM100000000S0HT |
| Model Year Start: 2016 | Model: Prius | Prod Date Range: [11/2015 -] |
| Title: 2ZR-FXE (COOLING): COOLING FAN SYSTEM: ON-VEHICLE INSPECTION; 2016 - 2019 MY Prius [11/2015 -] | | |

ON-VEHICLE INSPECTION

CAUTION / NOTICE / HINT

CAUTION:

To prevent injury due to contact with an operating cooling fan, keep your hands and clothing away from the cooling fans when inspecting the cooling fan system.

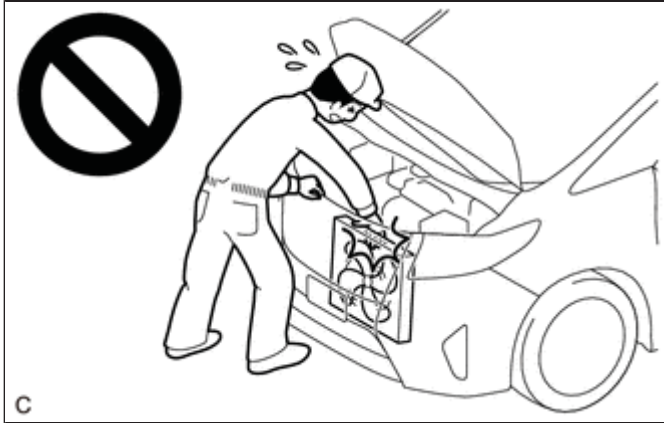

PROCEDURE

1. INSPECT COOLING FAN SYSTEM OPERATION AT LOW TEMPERATURES

CAUTION:

To prevent injury due to contact with an operating cooling fan, keep your hands and clothing away from the cooling fans when inspecting the cooling fan system.

- (a) Check and ensure the following conditions:
 - (1) The power switch is off.
 - (2) The engine coolant temperature is less than 94°C (201°F).
 - (3) The A/C switch is off.
- (b) Turn the power switch on (IG) and wait for approximately 10 seconds. Check that the cooling fans are not operating.
- (c) Check that the cooling fans operate when the water temperature sensor connector is disconnected.

2. INSPECT COOLING FAN SYSTEM OPERATION AT HIGH TEMPERATURES

CAUTION:

To prevent injury due to contact with an operating cooling fan, keep your hands and clothing away from the cooling fans when inspecting the cooling fan system.

- (a) Check and ensure the following conditions:
 - (1) Put the engine in inspection mode (maintenance mode).

Powertrain > Hybrid Control > Utility



Inspection Mode

- (2) Warm up the engine.
- (3) The engine coolant temperature is less than 94°C (201°F).
- (4) The A/C switch is off.
- (b) Start the engine. Check that the cooling fans are not operating.
- (c) Check that the cooling fans start operating when the engine coolant temperature reaches approximately 96°C (205°F).

HINT:

This system can also be checked using the Techstream.

Enter the following menus: Powertrain / Engine / Data List / Coolant Temperature

Powertrain > Engine > Data List

TESTER DISPLAY

Coolant Temperature



| | | |
|---|--------------|-------------------------------|
| Last Modified: 01-14-2019 | 6.8:8.0.48 | Doc ID: RM100000000S0HV |
| Model Year Start: 2016 | Model: Prius | Prod Date Range: [11/2015 -] |
| Title: 2ZR-FXE (COOLING): COOLING FAN SYSTEM: PARTS LOCATION; 2016 - 2019 MY Prius [11/2015 -] | | |

PARTS LOCATION

ILLUSTRATION

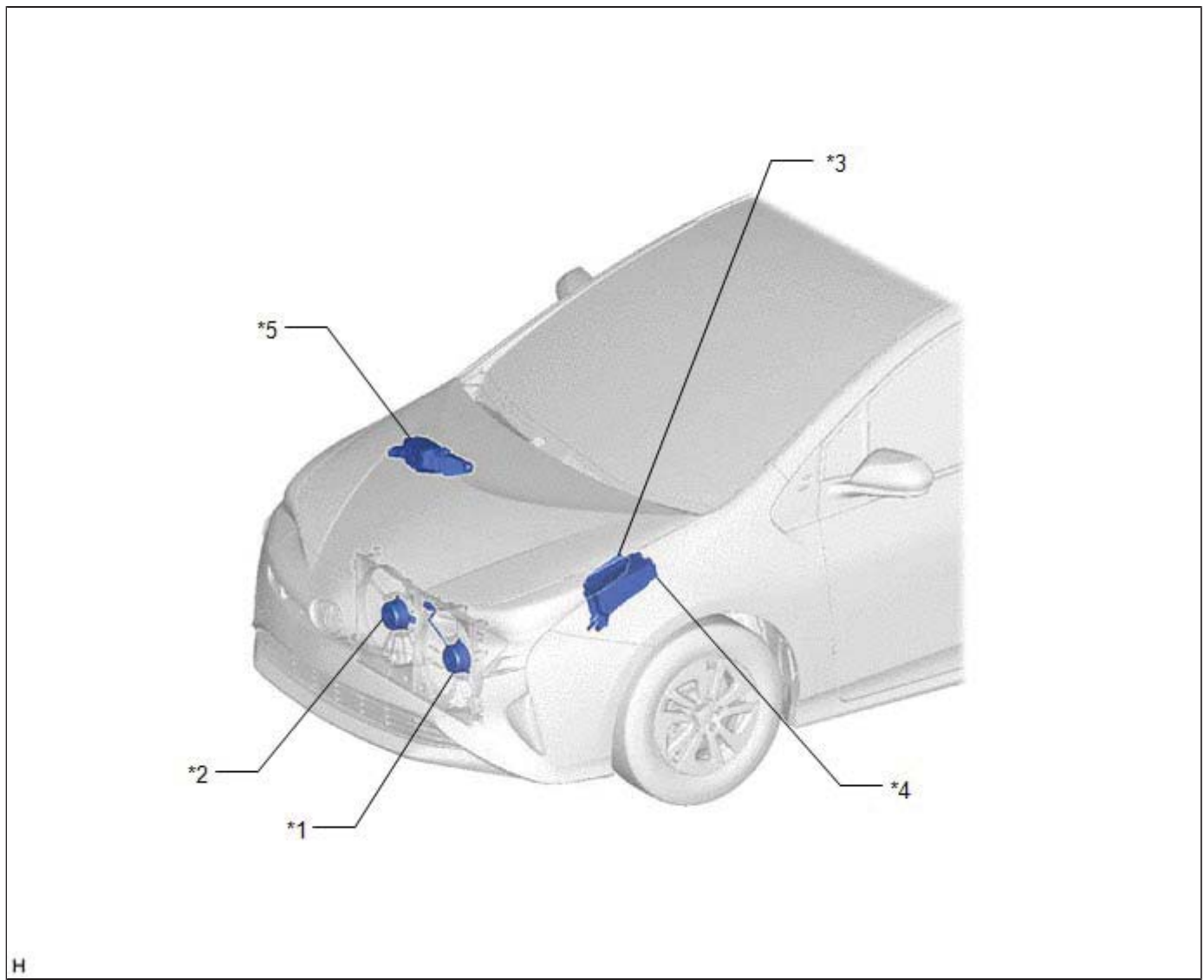

| | | | |
|----|---|----|--|
| *1 | COOLING FAN MOTOR | *2 | NO. 2 COOLING FAN MOTOR |
| *3 | ECM | *4 | NO. 1 ENGINE ROOM RELAY BLOCK AND NO. 1 JUNCTION BLOCK ASSEMBLY - INTEGRATION RELAY NO. 1 - FAN NO. 1 FUSE - FAN NO. 2 FUSE - EFI NO. 2 FUSE |
| *5 | NO. 2 RELAY BLOCK - FAN NO. 1 RELAY - FAN NO. 2 RELAY | - | - |

- FAN NO. 3 RELAY

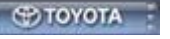

| | | |
|---|---------------------|---|
| Last Modified: 01-14-2019 | 6.8:8.0.48 | Doc ID: RM100000000SOHU |
| Model Year Start: 2016 | Model: Prius | Prod Date Range: [11/2015 - 12/2018] |
| Title: 2ZR-FXE (COOLING): COOLING FAN SYSTEM: PRECAUTION; 2016 - 2018 MY Prius [11/2015 - 12/2018] | | |

PRECAUTION

INITIALIZATION

NOTICE:

When disconnecting the cable from the negative (-) auxiliary battery terminal, initialize the following system(s) after the cable is reconnected.

| SYSTEM NAME | SEE PROCEDURE |
|---|---|
| Lane Departure Alert System (w/ Steering Control) |  |
| Intelligent Clearance Sonar System | |
| Simple Advanced Parking Guidance System | |
| Pre-collision System | |
| Power Door Lock Contrl System | |



| | | |
|--|---------------------|--------------------------------------|
| Last Modified: 01-14-2019 | 6.8:8.0.48 | Doc ID: RM100000000U219 |
| Model Year Start: 2016 | Model: Prius | Prod Date Range: [11/2015 -] |
| Title: 2ZR-FXE (COOLING): COOLING FAN SYSTEM: PROBLEM SYMPTOMS TABLE; 2016 - 2019 MY Prius [11/2015 -] | | |

PROBLEM SYMPTOMS TABLE

HINT:

- Use the table below to help determine the cause of problem symptoms. If multiple suspected areas are listed, the potential causes of the symptoms are listed in order of probability in the "Suspected Area" column of the table. Check each symptom by checking the suspected areas in the order they are listed. Replace parts as necessary.
- Inspect the fuses related to this system before inspecting the suspected areas below.

Cooling Fan System

| SYMPTOM | SUSPECTED AREA | LINK |
|--|-----------------------------------|----------------------|
| Cooling fans do not operate | Engine coolant temperature sensor | INFO |
| | Cooling fan motor LH | INFO |
| | Cooling fan motor RH | INFO |
| | FAN NO. 1 relay | INFO |
| | FAN NO. 2 relay | INFO |
| | FAN NO. 3 relay | INFO |
| | No. 1 integration relay | INFO |
| | Cooling fan circuit | INFO |
| Cooling fans do not stop (continue to operate) | ECM | INFO |
| | Engine coolant temperature sensor | INFO |
| | Cooling fan circuit | INFO |
| | FAN NO. 1 relay | INFO |
| | FAN NO. 2 relay | INFO |
| FAN NO. 3 relay | INFO | |

| | | |
|------------------------------------|----------------------|----------------------|
| | Cooling fan motor LH | INFO |
| | Cooling fan motor RH | INFO |
| | ECM | INFO |
| Cooling fans speed does not change | FAN NO. 2 relay | INFO |
| | Cooling fan circuit | INFO |
| | ECM | INFO |

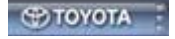

| | | |
|--|---------------------|--------------------------------------|
| Last Modified: 01-14-2019 | 6.8:8.0.48 | Doc ID: RM100000000S0HW |
| Model Year Start: 2016 | Model: Prius | Prod Date Range: [11/2015 -] |
| Title: 2ZR-FXE (COOLING): COOLING FAN SYSTEM: SYSTEM DIAGRAM; 2016 - 2019 MY Prius [11/2015 -] | | |

[SYSTEM DIAGRAM](#)

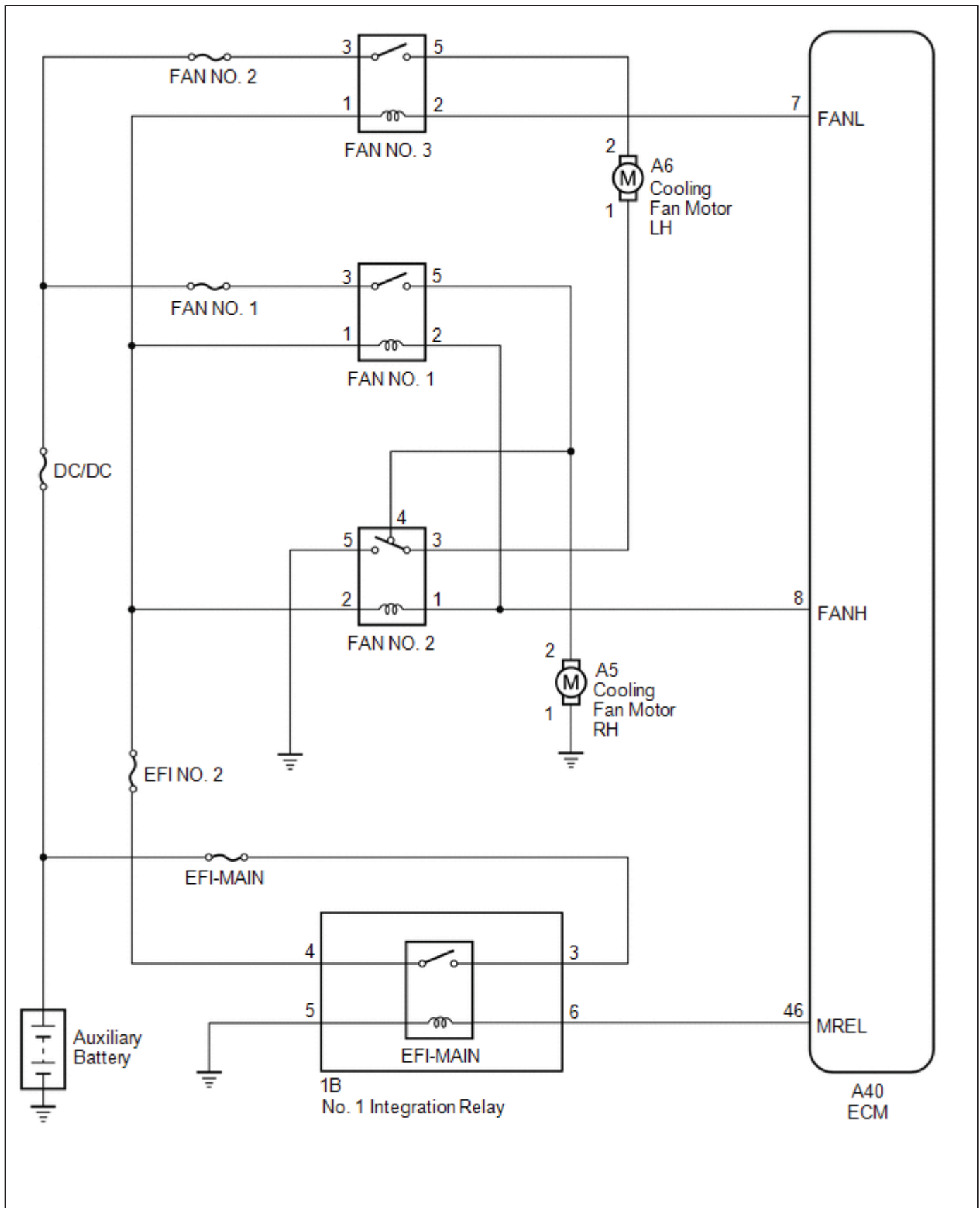

| | | |
|--|--------------|--------------------------------------|
| Last Modified: 01-14-2019 | 6.8:8.0.48 | Doc ID: RM100000000TC4G |
| Model Year Start: 2016 | Model: Prius | Prod Date Range: [11/2015 - 08/2016] |
| Title: 2ZR-FXE (COOLING): COOLING SYSTEM: ON-VEHICLE INSPECTION; 2016 MY Prius [11/2015 - 08/2016] | | |

ON-VEHICLE INSPECTION

CAUTION / NOTICE / HINT

CAUTION:

Do not remove the reserve tank cap and air release valve (w/ air release valve) while the engine or radiator assembly are still hot. Pressurized, hot engine coolant and steam may be released and cause serious burns.

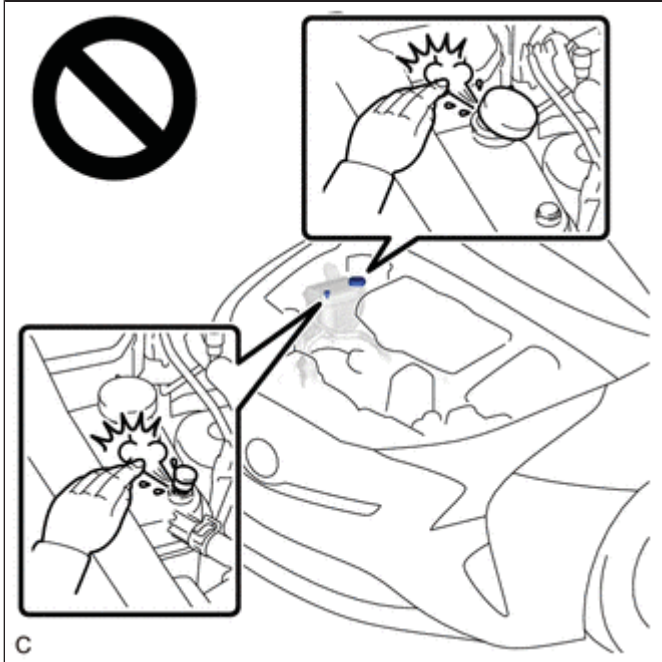

PROCEDURE

1. INSPECT FOR COOLANT LEAK (for Engine)

CAUTION:

Do not remove the reserve tank cap and air release valve (w/ air release valve) while the engine or radiator assembly are still hot. Pressurized, hot engine coolant and steam may be released and cause serious burns.

- (a) Remove the reserve tank cap.
- (b) Add engine coolant to the FULL line of the radiator reserve tank assembly.
- (c) Install a radiator cap tester.

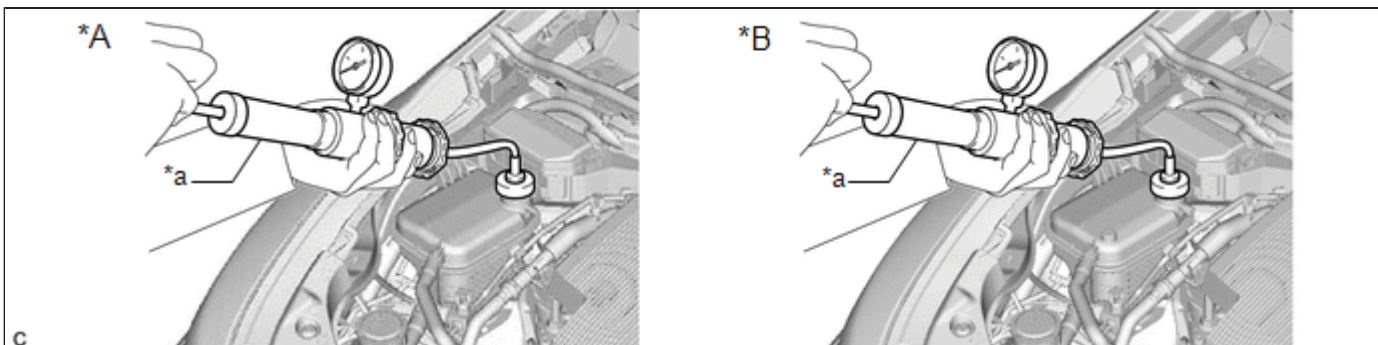

| | | | |
|----|-----------------------|----|----------------------|
| *A | w/o Air Release Valve | *B | w/ Air Release Valve |
| *a | Radiator Cap Tester | - | - |

(d) Put the engine in inspection mode (maintenance mode).

Powertrain > Hybrid Control > Utility

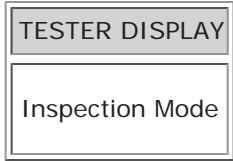

(e) Warm up the engine.

(f) Pump the radiator cap tester to 122 kPa (1.2 kgf/cm², 17 psi), and then check that the pressure does not drop.

- If the pressure drops, check the hoses, radiator assembly and engine water pump assembly for leaks.
- If there are no signs of external engine coolant leaks, check the heater core, cylinder block sub-assembly and cylinder head sub-assembly.

(g) Remove the radiator cap tester.

(h) Install the reserve tank cap.

2. INSPECT RADIATOR RESERVE TANK ENGINE COOLANT LEVEL (for Engine)

(a) Check that the engine coolant level is between the LOW line and FULL line when the engine is cold.

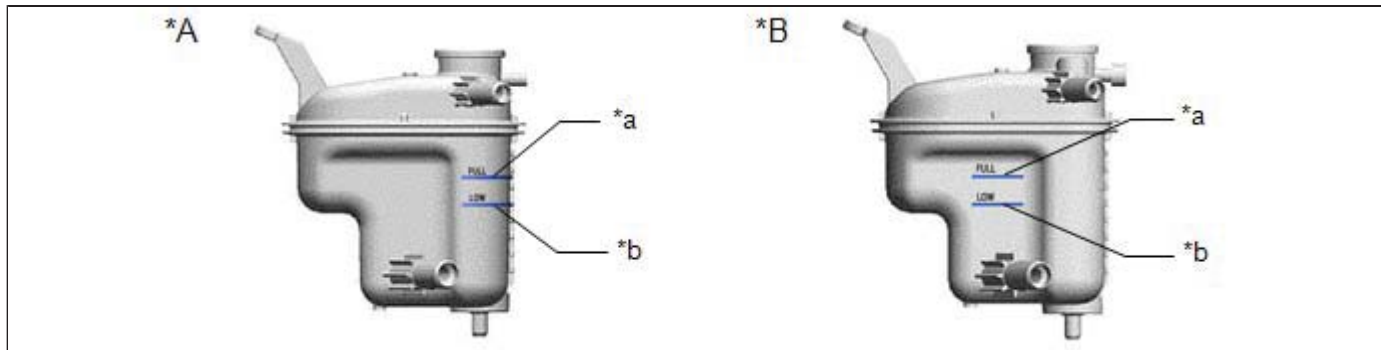

| | | | |
|----|-----------------------|----|----------------------|
| *A | w/o Air Release Valve | *B | w/ Air Release Valve |
| *a | FULL Line | *b | LOW Line |

If the engine coolant level is low, check for leaks and add engine coolant to the FULL line.

NOTICE:

- Do not substitute plain water for engine coolant.
- The coolant levels in the compartments inside the radiator reserve tank assembly may differ, but this is not a malfunction.

3. INSPECT ENGINE COOLANT QUALITY (for Engine)

CAUTION:

Do not remove the reserve tank cap and air release Valve (w/ air release Valve) while the engine or radiator assembly are still hot. Pressurized, hot engine coolant and steam may be released and cause serious burns.

(a) Remove the reserve tank cap.

(b) Check if there are any excessive deposits of rust or scale around the reserve tank cap and radiator reserve tank filler hole. Also, the engine coolant should be free of oil.

If excessively dirty, clean the engine coolant passage and replace the engine coolant.

(c) Install the reserve tank cap.

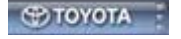

| | | |
|--|---------------------|--------------------------------------|
| Last Modified: 01-14-2019 | 6.8:8.0.48 | Doc ID: RM100000000U3LB |
| Model Year Start: 2016 | Model: Prius | Prod Date Range: [11/2015 -] |
| Title: 2ZR-FXE (COOLING): EXHAUST HEAT RECIRCULATION SYSTEM: Exhaust Heat Recirculation System Circuit; 2016 - 2019 MY Prius [11/2015 -] | | |

Exhaust Heat Recirculation System Circuit

DESCRIPTION

In the exhaust heat recirculation system, coolant is warmed up using conventionally wasted exhaust gas heat to accelerate engine warm-up time, enhancing fuel efficiency and heater performance.

The heat recirculator is positioned in the front exhaust pipe assembly after the catalyst. Coolant from the engine flows around the heat recirculator and then returns to the engine. If the engine is started while the engine is cold, the exhaust pipe gas control actuator rod is contracted and the exhaust flow control valve is closed, routing the exhaust gas around the heat recirculator to warm up the coolant.

After the engine coolant temperature rises and the engine has warmed up, the heat of the coolant expands the thermostat and the exhaust pipe gas control actuator rod extends. This opens the exhaust flow control valve to switch to the normal exhaust gas path.

The exhaust flow control valve can also be opened by exhaust gas pressure to prevent insufficient acceleration performance when the engine is cold. In addition, to monitor the engine coolant temperature, an engine coolant temperature sensor (for exhaust heat recirculation system) is provided between the engine and the heat recirculator. The engine coolant temperature sensor (for exhaust heat recirculation system) has a built-in thermistor with a resistance that varies according to the temperature of the engine coolant. When the engine coolant temperature becomes low, the resistance of the thermistor increases. When the temperature becomes high, the resistance drops. These variations in resistance are transmitted to the combination meter assembly as voltage changes. If the engine coolant temperature is excessively high (overheating), the water temperature indicator light in the meter circuit plates (combination meter assembly) illuminate to inform the driver of the malfunction.

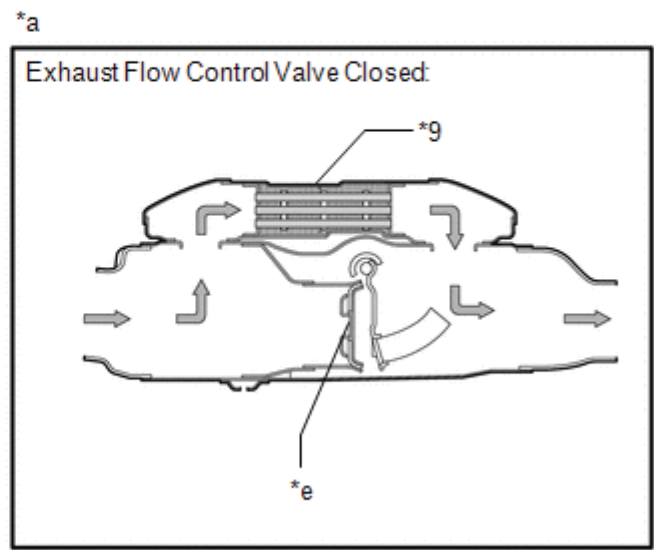
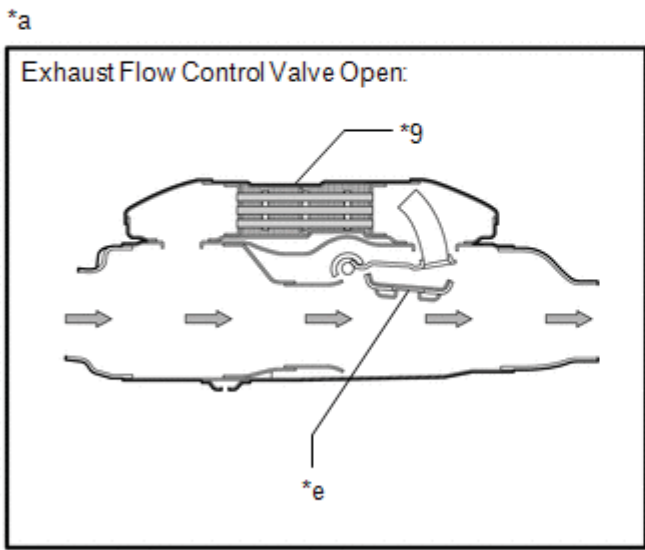
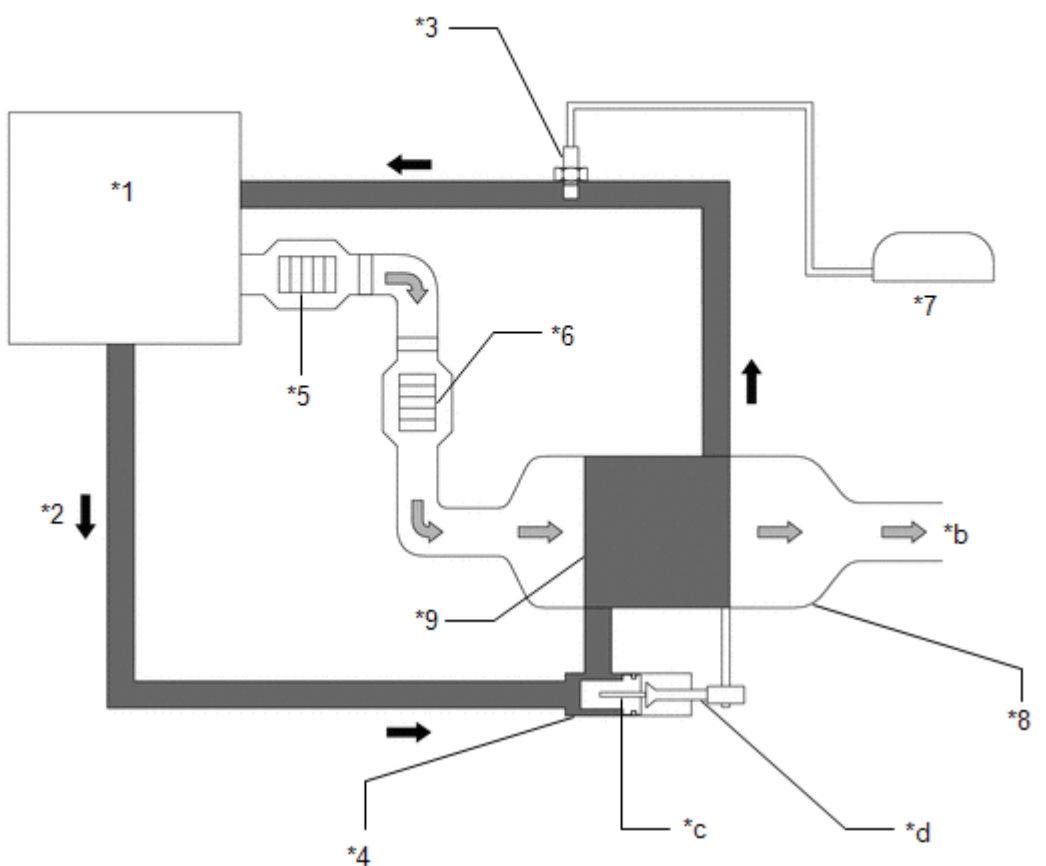

Text in Illustration

| | | | |
|----|---|----|-----------------------------------|
| *1 | Engine Assembly | *2 | Engine Coolant |
| *3 | Engine Coolant Temperature Sensor (for Exhaust Heat Recirculation System) | *4 | Exhaust Pipe Gas Control Actuator |
| *5 | Front Catalyst | *6 | Rear Catalyst |

| | | | |
|----|--|----|-----------------------------|
| *7 | Meter Circuit Plate (Combination Meter Assembly) | *8 | Front Exhaust Pipe Assembly |
| *9 | Heat Recirculator | - | - |
| *a | Side View | *b | Exhaust Gas |
| *c | Thermostat | *d | Rod |
| *e | Exhaust Flow Control Valve | - | - |

WIRING DIAGRAM

Refer to System Diagram.

Click here 

PROCEDURE

| | |
|----|---|
| 1. | CHECK HARNESS AND CONNECTOR (ENGINE COOLANT TEMPERATURE SENSOR - METER CIRCUIT PLATE (COMBINATION METER ASSEMBLY)) |
|----|---|

(a) Disconnect the A10 engine coolant temperature sensor (for exhaust heat recirculation system) connector.

(b) Disconnect the F6 meter circuit plate (combination meter assembly) connector.

(c) Measure the resistance according to the value(s) in the table below.

Standard Resistance (Check for Open):



[Click Location & Routing\(A10\)](#)

[Click Location & Routing\(F6\)](#)

[Click Connector\(A10\)](#)

[Click Connector\(F6\)](#)

| TESTER CONNECTION | CONDITION | SPECIFIED CONDITION |
|-----------------------------|-----------|---------------------|
| A10-2 (TWS3) - F6-23 (TWS3) | Always | Below 1 Ω |
| A10-1 (E2) - F6-3 (E2) | Always | Below 1 Ω |

Standard Resistance (Check for Short):



[Click Location & Routing\(A10\)](#)

[Click Location & Routing\(F6\)](#)

[Click Connector\(A10\)](#)

[Click Connector\(F6\)](#)

| TESTER CONNECTION | CONDITION | SPECIFIED CONDITION |
|--|-----------|-------------------------|
| A10-2 (TWS3) or F6-23 (TWS3) - Body ground | Always | 10 k Ω or higher |

REPAIR OR REPLACE HARNESS OR CONNECTOR (ENGINE

NG ► **COOLANT TEMPERATURE SENSOR - METER CIRCUIT PLATE
(COMBINATION METER ASSEMBLY))**

OK
▼

| | |
|----|--|
| 2. | INSPECT ENGINE COOLANT TEMPERATURE SENSOR (FOR EXHAUST HEAT RECIRCULATION SYSTEM) |
|----|--|

(a) Inspect the engine coolant temperature sensor (for exhaust heat recirculation system).

Click here [INFO](#)

OK ► **REPLACE METER CIRCUIT PLATE (COMBINATION METER ASSEMBLY)**

NG ► **REPLACE ENGINE COOLANT TEMPERATURE SENSOR (FOR EXHAUST HEAT RECIRCULATION SYSTEM)**

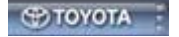

| | | |
|--|---------------------|---|
| Last Modified: 01-14-2019 | 6.8: 8.0.48 | Doc ID: RM100000000SONX |
| Model Year Start: 2016 | Model: Prius | Prod Date Range: [11/2015 - 08/2016] |
| Title: 2ZR-FXE (COOLING): EXHAUST HEAT RECIRCULATION SYSTEM: ON-VEHICLE INSPECTION; 2016 MY Prius [11/2015 - 08/2016] | | |

ON-VEHICLE INSPECTION

PROCEDURE

1. INSPECT FRONT EXHAUST PIPE ASSEMBLY (TWC: Rear Catalyst)

(a) Inspect the exhaust flow control valve operation.

- (1) Using a screwdriver, move the exhaust flow control valve from the bottom of the vehicle. Check that the valve moves smoothly.

OK:

Valve moves smoothly.

If the valve is stuck or does not move smoothly, replace the front exhaust pipe assembly (TWC: Rear Catalyst).

HINT:

[Click here](#)

INFO

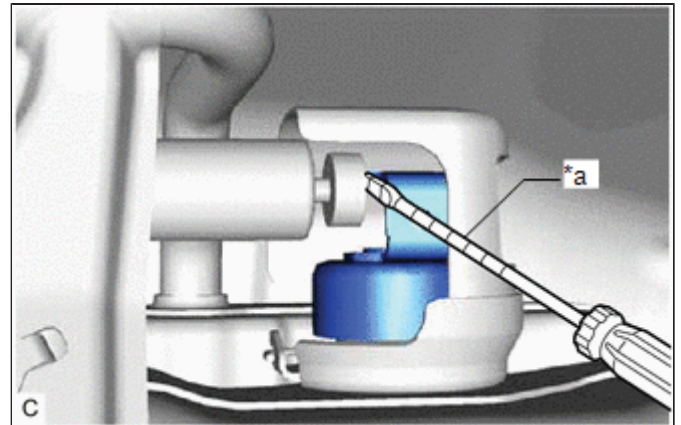

| | |
|----|-----------------|
| *a | Protective Tape |
|----|-----------------|

(b) Inspect the exhaust pipe gas control actuator sub-assembly.

- (1) Connect the Techstream to the DLC3.
- (2) Turn the power switch on (IG).
- (3) Turn the Techstream on.
- (4) Enter the following menus: Powertrain / Engine / Data List / Coolant Temperature.

Powertrain > Engine > Data List

| |
|---------------------|
| TESTER DISPLAY |
| Coolant Temperature |

- (5) While checking the engine coolant temperature with the Techstream, check the operation of the exhaust pipe gas control actuator rod when the temperature rises.

Standard:

| CONDITION | ROD OPERATION |
|--|---------------------------------------|
| Cold (below approximately 71°C (160°F)) → Warmed up (approximately | Rod gradually extends smoothly as the |

80°C (176°F) or higher)

temperature rises

If the exhaust pipe gas control actuator rod does not extend smoothly, replace the exhaust pipe gas control actuator sub-assembly.

HINT:

- Click here [INFO](#)
- After the engine has warmed up (the thermostat temperature is approximately 80°C (176°F) or higher), the rod should be extended approximately 7.2 mm (0.283 in.) or more compared to when the engine is cold (the thermostat temperature is below approximately 71°C (160°F)).
- The coolant temperature shown in the Data List may slightly deviate from the thermostat temperature. This is because the Data List value indicates the temperature detected by the engine coolant temperature sensor, which is mounted on the engine, while the thermostat is positioned in the exhaust pipe gas control actuator sub-assembly.
- If it is difficult to check while the rod is operating, allow the engine to cool down until the coolant temperature matches the ambient temperature and then check the rod operation again.

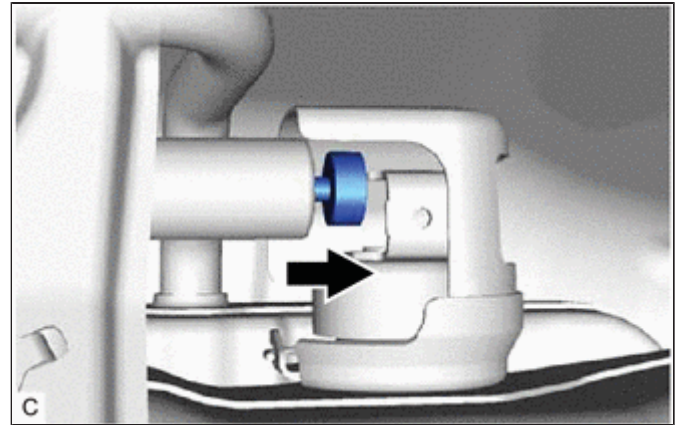

(6) Check for any cracks or damage on the exhaust pipe gas control actuator rod.

OK:

No cracks or damage is found.

If any cracks or damage is found, replace the front exhaust pipe assembly (TWC: Rear Catalyst).

HINT:

Click here [INFO](#)

2. INSPECT FOR ENGINE COOLANT LEAK FROM FRONT EXHAUST PIPE ASSEMBLY (TWC: Rear Catalyst)

CAUTION:

Do not remove the reserve tank cap and air release valve (w/ air release valve) while the engine or radiator assembly are still hot. Pressurized, hot engine coolant and steam may be released and cause serious burns.

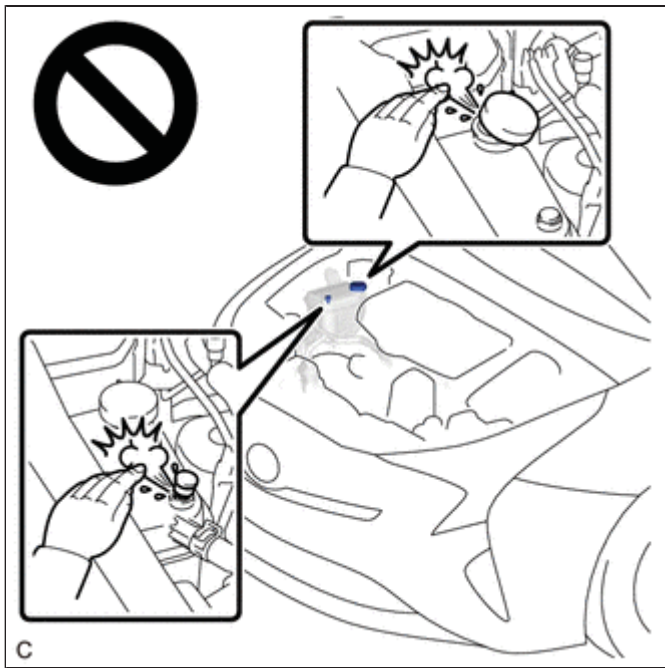

NOTICE:

Before performing this inspection, turn the A/C switch off.

- (a) Turn the power switch off. Check for engine coolant leaks from the front exhaust pipe assembly (TWC: Rear Catalyst) and the heater water hose around the engine coolant temperature sensor.
- (b) Remove the reserve tank cap.
- (c) Add engine coolant to the FULL line of the radiator reserve tank assembly.
- (d) Install a radiator cap tester.

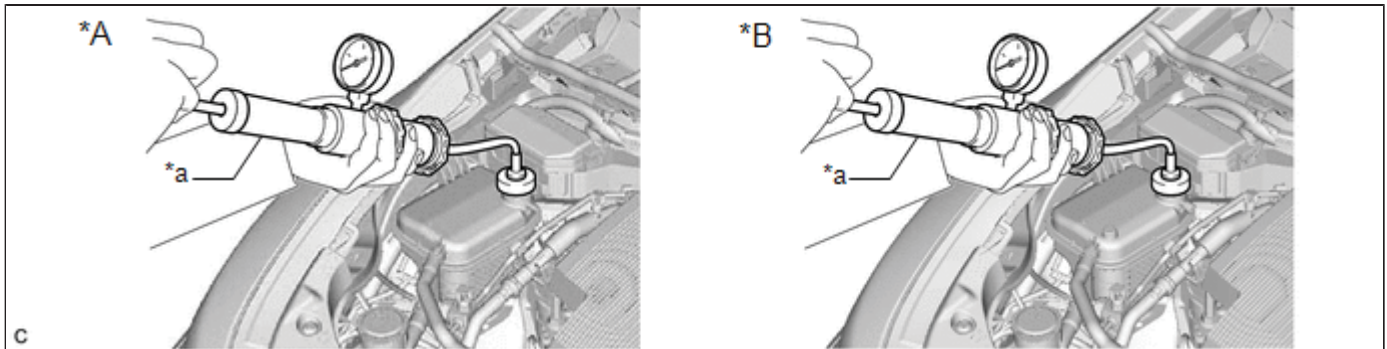

| | | | |
|----|-----------------------|----|----------------------|
| *A | w/o Air Release Valve | *B | w/ Air Release Valve |
| *a | Radiator Cap Tester | - | - |

- (e) Put the engine in inspection mode (maintenance mode).

Powertrain > Hybrid Control > Utility

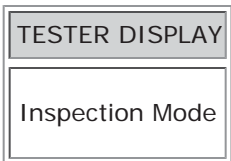

- (f) Warm up the engine.
- (g) Pump the radiator cap tester to 123 kPa (1.3 kgf/cm², 18 psi), and then check that the pressure does not drop.

If the pressure drops, check the front exhaust pipe assembly (TWC: Rear Catalyst) and the heater water hose around the engine coolant temperature sensor for leaks.

(h) Remove the radiator cap tester.

(i) Install the reserve tank cap.

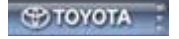

| | | |
|---|---------------------|--------------------------------------|
| Last Modified: 01-14-2019 | 6.8:8.0.48 | Doc ID: RM100000000SONU |
| Model Year Start: 2016 | Model: Prius | Prod Date Range: [11/2015 -] |
| Title: 2ZR-FXE (COOLING): EXHAUST HEAT RECIRCULATION SYSTEM: PARTS LOCATION; 2016 - 2019 MY Prius [11/2015 -] | | |

[PARTS LOCATION](#)

[ILLUSTRATION](#)

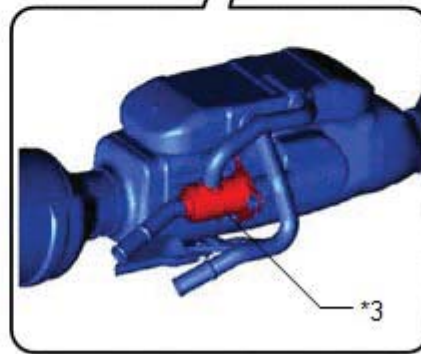
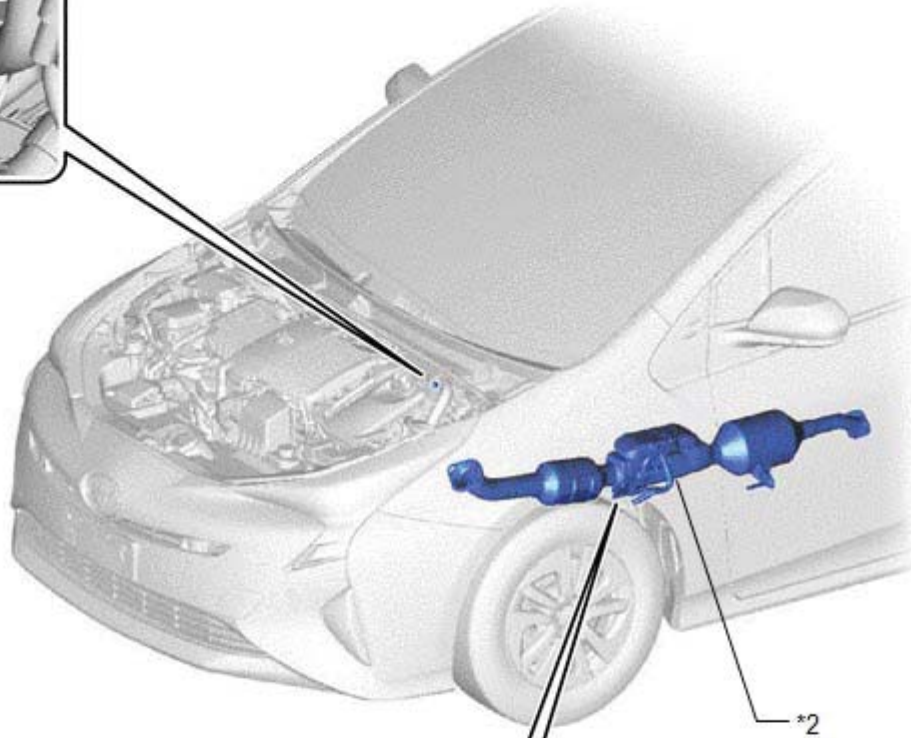
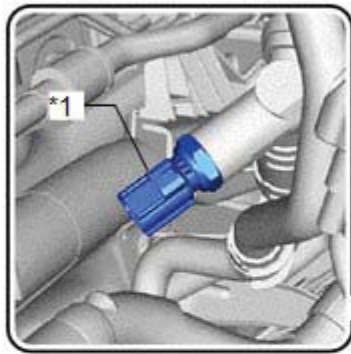

H

| | | | |
|----|--|----|-----------------------------|
| *1 | ENGINE COOLANT TEMPERATURE SENSOR | *2 | FRONT EXHAUST PIPE ASSEMBLY |
| *3 | EXHAUST PIPE GAS CONTROL ACTUATOR SUB-ASSEMBLY | - | - |

ILLUSTRATION



H

| | | | |
|----|----------------------------|---|---|
| *1 | COMBINATION METER ASSEMBLY | - | - |
|----|----------------------------|---|---|

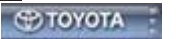

| | | |
|--|---------------------|---|
| Last Modified: 01-14-2019 | 6.8:8.0.48 | Doc ID: RM100000000SONZ |
| Model Year Start: 2016 | Model: Prius | Prod Date Range: [11/2015 - 12/2018] |
| Title: 2ZR-FXE (COOLING): EXHAUST HEAT RECIRCULATION SYSTEM: PRECAUTION; 2016 - 2018 MY Prius [11/2015 - 12/2018] | | |

PRECAUTION

PRECAUTION FOR DISCONNECTING CABLE FROM NEGATIVE BATTERY TERMINAL

NOTICE:

When disconnecting the cable from the negative (-) auxiliary battery terminal, initialize the following systems after the cable is reconnected.

| SYSTEM NAME | SEE PROCEDURE |
|---|---|
| Lane Departure Alert System (w/ Steering Control) |  |
| Intelligent Clearance Sonar System | |
| Simple Advanced Parking Guidance System | |
| Pre-collision System | |
| Power Door Lock Contrl System | |



| | | |
|---|---------------------|--------------------------------------|
| Last Modified: 01-14-2019 | 6.8:8.0.48 | Doc ID: RM100000000S0NV |
| Model Year Start: 2016 | Model: Prius | Prod Date Range: [11/2015 -] |
| Title: 2ZR-FXE (COOLING): EXHAUST HEAT RECIRCULATION SYSTEM: PROBLEM SYMPTOMS TABLE; 2016 - 2019 MY Prius [11/2015 -] | | |

PROBLEM SYMPTOMS TABLE

HINT:

- Use the table below to help determine the cause of problem symptoms. If multiple suspected areas are listed, the potential causes of the symptoms are listed in order of probability in the "Suspected Area" column of the table. Check each symptom by checking the suspected areas in the order they are listed. Replace parts as necessary.
- Inspect the fuses and relays related to this system before inspecting the suspected areas below.

Exhaust Heat Recirculation System

| SYMPTOM | SUSPECTED AREA | LINK |
|--------------------|---|---|
| Engine overheating | Engine overheating | INFO INFO |
| | Engine coolant leaks (for exhaust heat recirculation system) | INFO INFO |
| | Front exhaust pipe assembly | INFO INFO |
| | Exhaust pipe gas control actuator | INFO |
| | Exhaust heat recirculation system circuit | INFO |
| | Engine coolant temperature sensor (for exhaust heat recirculation system) | INFO |



Last Modified: 01-14-2019

6.8:8.0.48

Doc ID: RM100000000SONW

Model Year Start: 2016

Model: Prius

Prod Date Range: [11/2015 -]

Title: 2ZR-FXE (COOLING): EXHAUST HEAT RECIRCULATION SYSTEM: SYSTEM DIAGRAM; 2016 - 2019 MY Prius [11/2015 -]

SYSTEM DIAGRAM

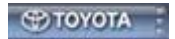
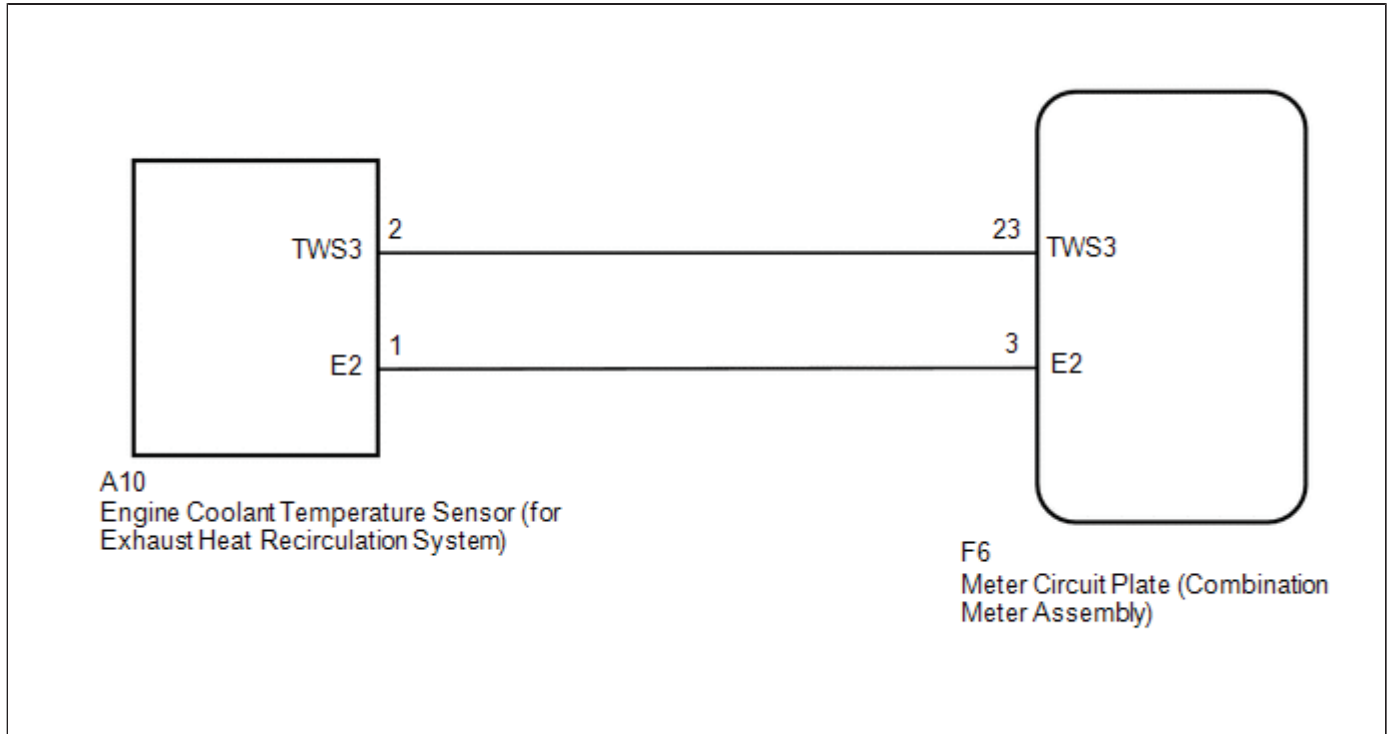

| | | |
|---|---------------------|--------------------------------------|
| Last Modified: 01-14-2019 | 6.8:8.0.48 | Doc ID: RM100000000TJ56 |
| Model Year Start: 2016 | Model: Prius | Prod Date Range: [11/2015 -] |
| Title: 2ZR-FXE (COOLING): EXHAUST PIPE GAS CONTROL ACTUATOR: COMPONENTS; 2016 - 2019 MY Prius [11/2015 -] | | |

COMPONENTS

ILLUSTRATION

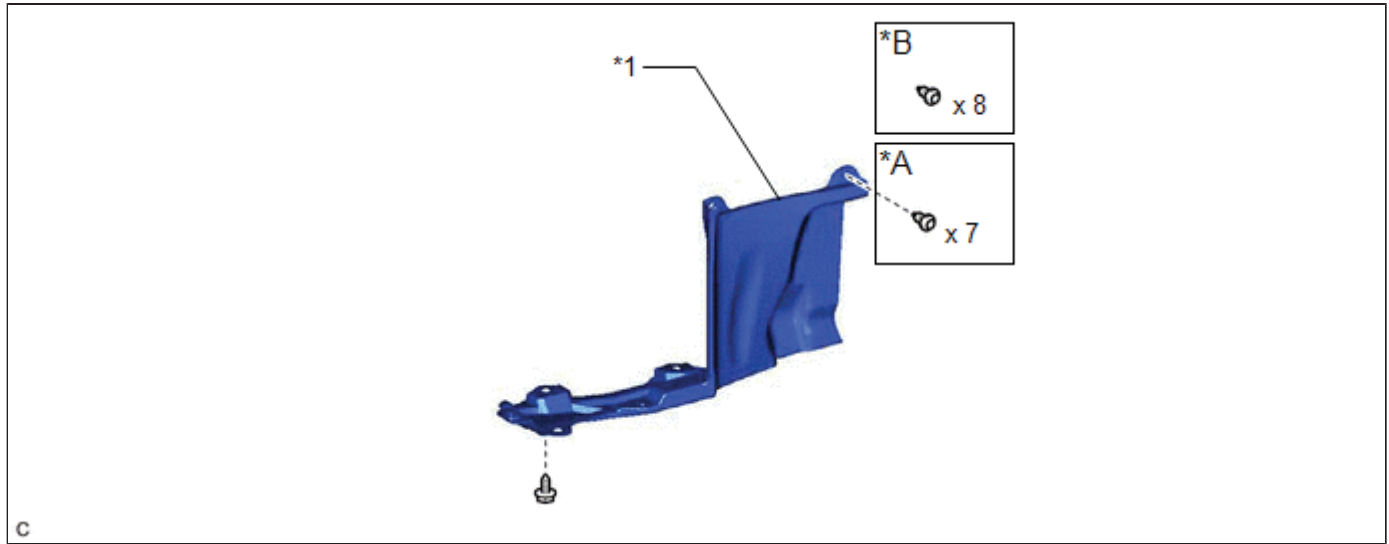

| | | | |
|----|---|----|--|
| *A | except Rough Road Area Specification Vehicles | *B | for Rough Road Area Specification Vehicles |
| *1 | REAR MOTOR UNDER COVER LH | - | - |

ILLUSTRATION

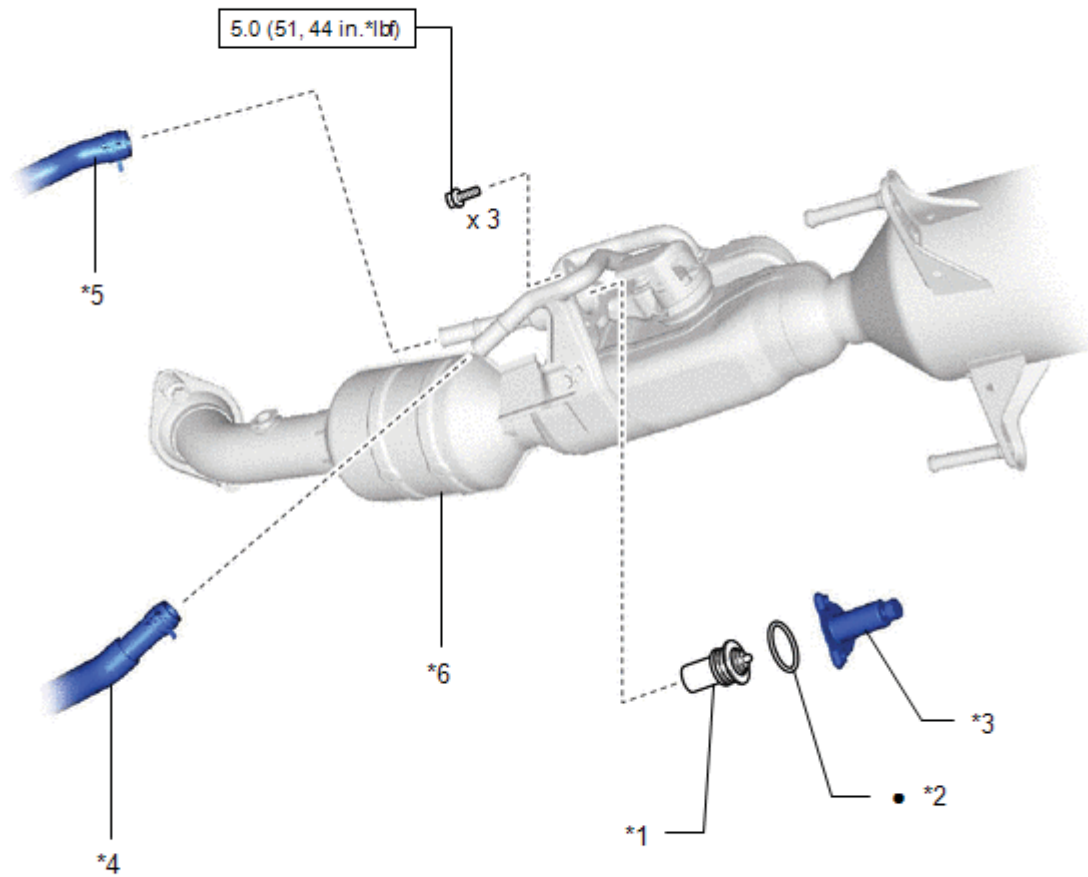

c

| | | | |
|----|--|----|--|
| *1 | EXHAUST PIPE GAS CONTROL ACTUATOR | *2 | EXHAUST PIPE GAS CONTROL ACTUATOR GASKET |
| *3 | EXHAUST PIPE GAS CONTROL ACTUATOR SUB-ASSEMBLY | *4 | OUTLET HEATER WATER HOSE B |
| *5 | OUTLET HEATER WATER HOSE C | *6 | FRONT EXHAUST PIPE ASSEMBLY (TWC: Front and Rear Catalyst) |
| | N*m (kgf*cm, ft.*lbf): Specified torque | | Non-reusable part |



| | | |
|--|--------------|-------------------------------|
| Last Modified: 01-14-2019 | 6.8:8.0.48 | Doc ID: RM100000000TJ55 |
| Model Year Start: 2016 | Model: Prius | Prod Date Range: [11/2015 -] |
| Title: 2ZR-FXE (COOLING): EXHAUST PIPE GAS CONTROL ACTUATOR: INSTALLATION; 2016 - 2019 MY Prius [11/2015 -] | | |

INSTALLATION

PROCEDURE

1. INSTALL EXHAUST PIPE GAS CONTROL ACTUATOR

(a) Clean the installation surfaces and bolt holes of the exhaust pipe gas control actuator sub-assembly and front exhaust pipe assembly (TWC: Rear Catalyst).

NOTICE:

Make sure no foreign matter enters to the exhaust pipe gas control actuator sub-assembly and front exhaust pipe assembly (TWC: Rear Catalyst).

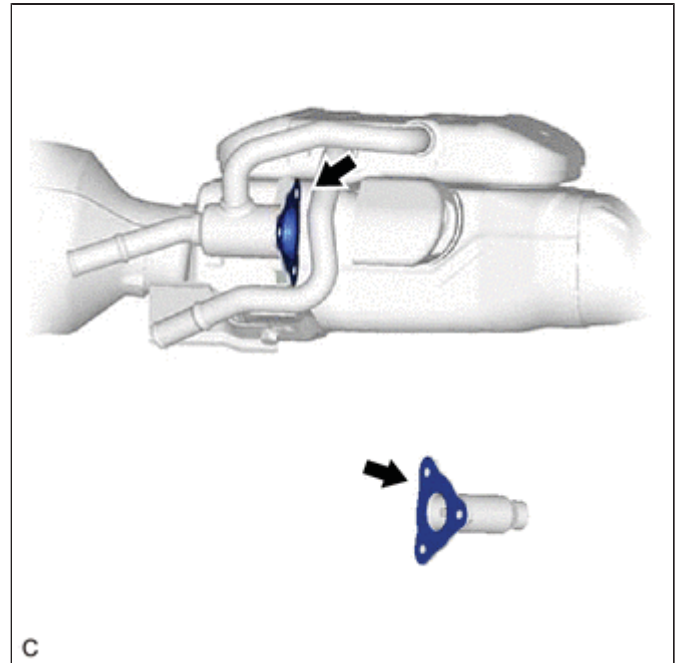

(b) Apply clean engine coolant to the O-ring.

NOTICE:

Check that the O-ring is not deformed, cracked or swollen.

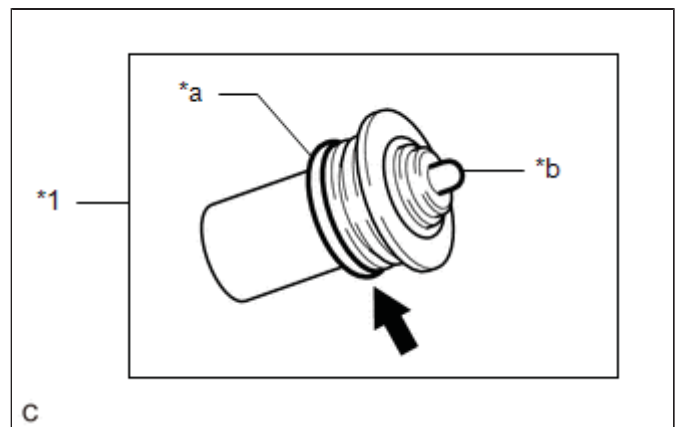

| | |
|----|-----------------------------------|
| *1 | Exhaust Pipe Gas Control Actuator |
| *a | O-ring |
| *b | Piston |

(c) Install the exhaust pipe gas control actuator.

NOTICE:

- When installing the exhaust pipe gas control actuator, do not push on the piston.
- Make sure that the exhaust pipe gas control actuator is free of oil.

(d) Install a new exhaust pipe gas control actuator gasket and the exhaust pipe gas control actuator sub-assembly with the 3 bolts.

Torque:

5.0 N·m {51 kgf·cm, 44 in·lbf}

NOTICE:

- Check that the O-ring is not deformed, cracked or swollen.
- Make sure that the exhaust pipe gas control actuator gasket and exhaust pipe gas control actuator sub-assembly are free of oil.

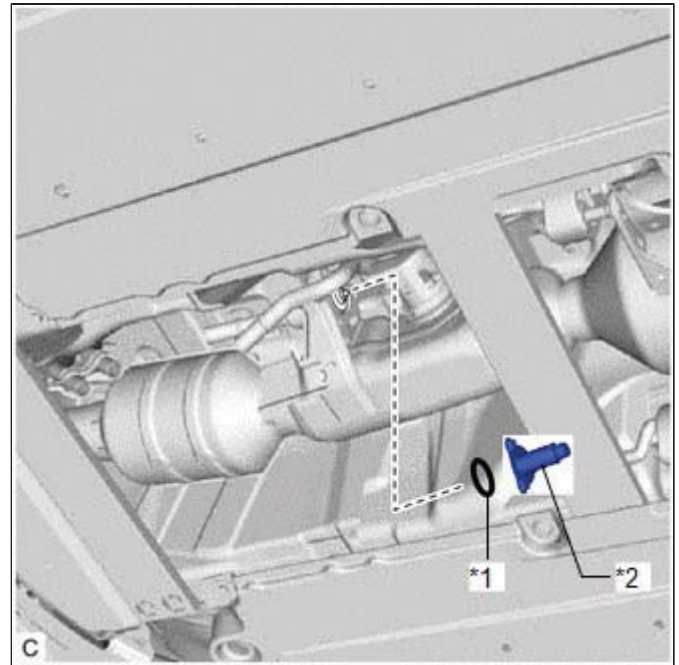

| | |
|----|--|
| *1 | Exhaust Pipe Gas Control Actuator Gasket |
| *2 | Exhaust Pipe Gas Control Actuator Sub-assembly |

(e) Using a screwdriver with the tip taped, pry the portion indicated in the illustration to engage the spring.

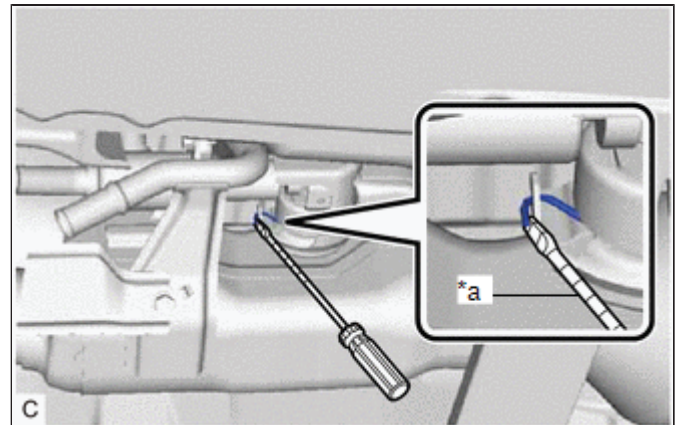

| | |
|----|-----------------|
| *a | Protective Tape |
|----|-----------------|

(f) Connect the outlet heater water hose B and outlet heater water hose C to the No. 2 outlet water pipe and inlet water pipe and slide the 2 clips to secure them.

NOTICE:

When installing the outlet heater water hose B and outlet heater water hose C, ensure that the exhaust heat recirculation system is filled with coolant. Otherwise, the engine water pump assembly may be damaged.

2. ADD ENGINE COOLANT (for Engine)

Click here [INFO](#) [INFO](#)

3. INSPECT FOR COOLANT LEAK (for Engine)

Click here [INFO](#) [INFO](#)

4. INSTALL REAR MOTOR UNDER COVER LH

Click here [INFO](#)

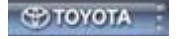

| | | |
|---|--------------|-------------------------------|
| Last Modified: 01-14-2019 | 6.8:8.0.48 | Doc ID: RM100000000TJ57 |
| Model Year Start: 2016 | Model: Prius | Prod Date Range: [11/2015 -] |
| Title: 2ZR-FXE (COOLING): EXHAUST PIPE GAS CONTROL ACTUATOR: REMOVAL; 2016 - 2019 MY Prius [11/2015 -] | | |

REMOVAL

PROCEDURE

1. REMOVE REAR MOTOR UNDER COVER LH

Click here [INFO](#)

2. DRAIN ENGINE COOLANT (for Engine)

Click here [INFO](#) [INFO](#)

3. REMOVE EXHAUST PIPE GAS CONTROL ACTUATOR

CAUTION:

- To prevent burns, do not touch the engine, exhaust pipe or other high temperature components while the engine is



hot.

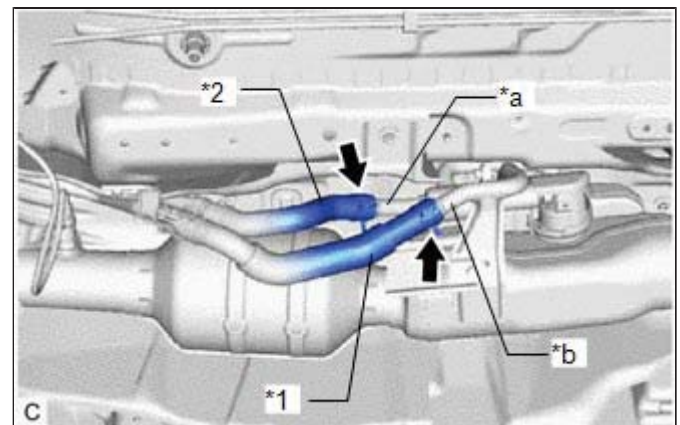

- (a) Slide the 2 clips and disconnect the outlet heater water hose B and outlet heater water hose C from the inlet water pipe and No. 2 outlet water pipe.

| | |
|----|----------------------------|
| *1 | Outlet Heater Water Hose B |
| *2 | Outlet Heater Water Hose C |
| *a | No. 2 Outlet Water Pipe |
| *b | Inlet Water Pipe |

(b) Using a screwdriver with the tip taped, pry the portion indicated in the illustration to disengage the spring.

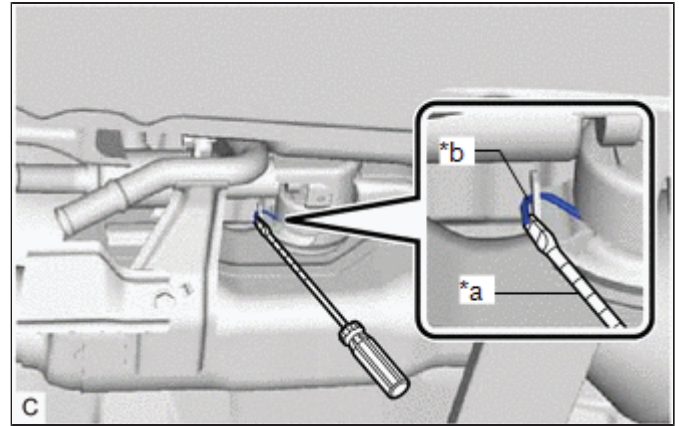

| | |
|----|-----------------|
| *a | Protective Tape |
| *b | Spring |

(c) Remove the 3 bolts and exhaust pipe gas control actuator sub-assembly and exhaust pipe gas control actuator gasket.

NOTICE:

- When removing the exhaust pipe gas control actuator sub-assembly, use caution because coolant may spill out from the exhaust heat recirculation system.
- Do not apply any excessive force to the No. 1 outlet water pipe, No. 2 outlet water pipe and inlet water pipe when removing the exhaust pipe gas control actuator sub-assembly.

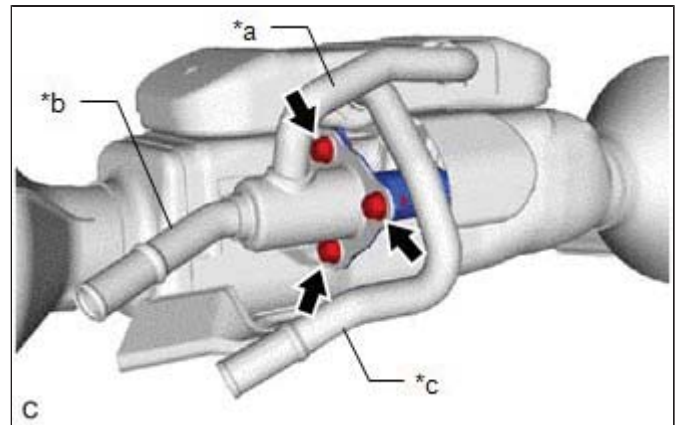

| | |
|----|-------------------------|
| *a | No. 1 Outlet Water Pipe |
| *b | No. 2 Outlet Water Pipe |
| *c | Inlet Water Pipe |

(d) While closing No. 2 outlet water pipe, apply compressed air to inlet water pipe to remove the exhaust pipe gas control actuator shown in the illustration.

HINT:

Use a piece of cloth to catch the exhaust pipe gas control

actuator.

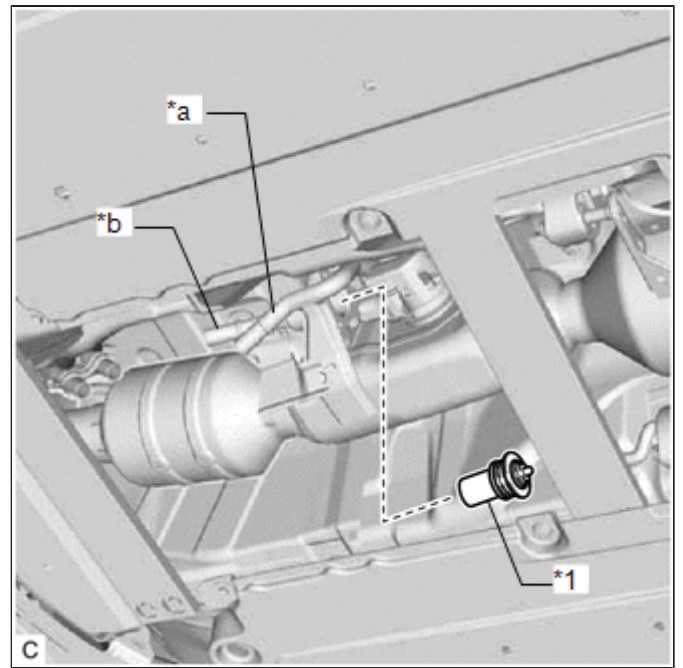

| | |
|----|-----------------------------------|
| *1 | Exhaust Pipe Gas Control Actuator |
| *a | No. 2 Outlet Water Pipe |
| *b | Inlet Water Pipe |



| | | |
|---|--------------|-------------------------------|
| Last Modified: 01-14-2019 | 6.8:8.0.48 | Doc ID: RM100000000TC4T |
| Model Year Start: 2016 | Model: Prius | Prod Date Range: [11/2015 -] |
| Title: 2ZR-FXE (COOLING): RADIATOR: COMPONENTS; 2016 - 2019 MY Prius [11/2015 -] | | |

COMPONENTS

ILLUSTRATION

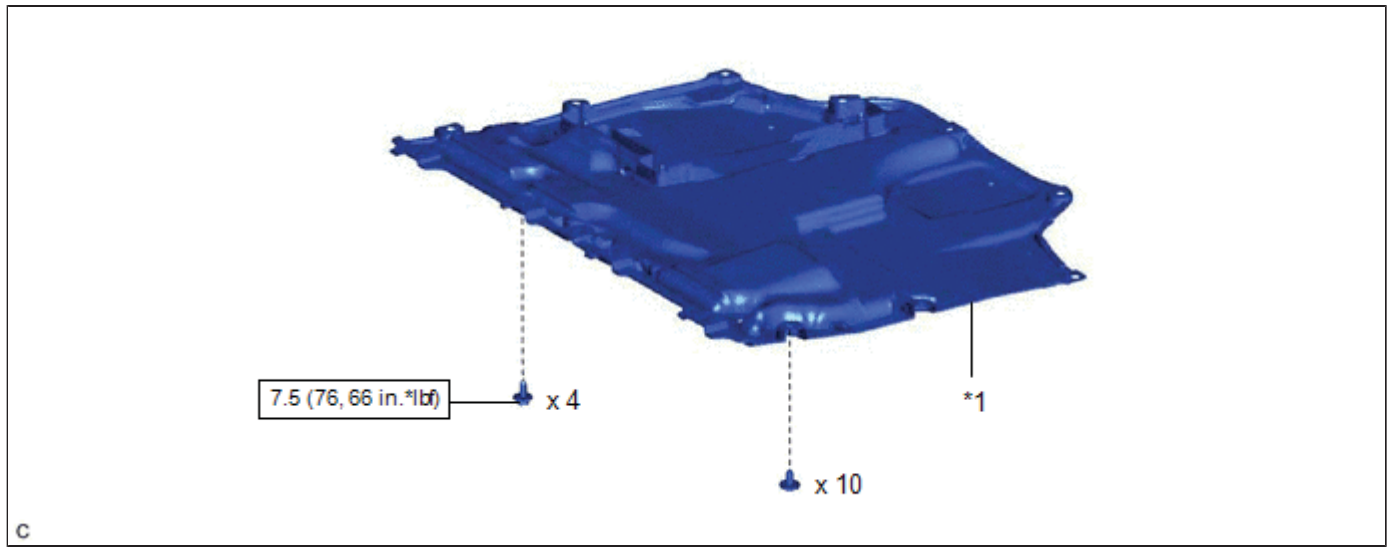

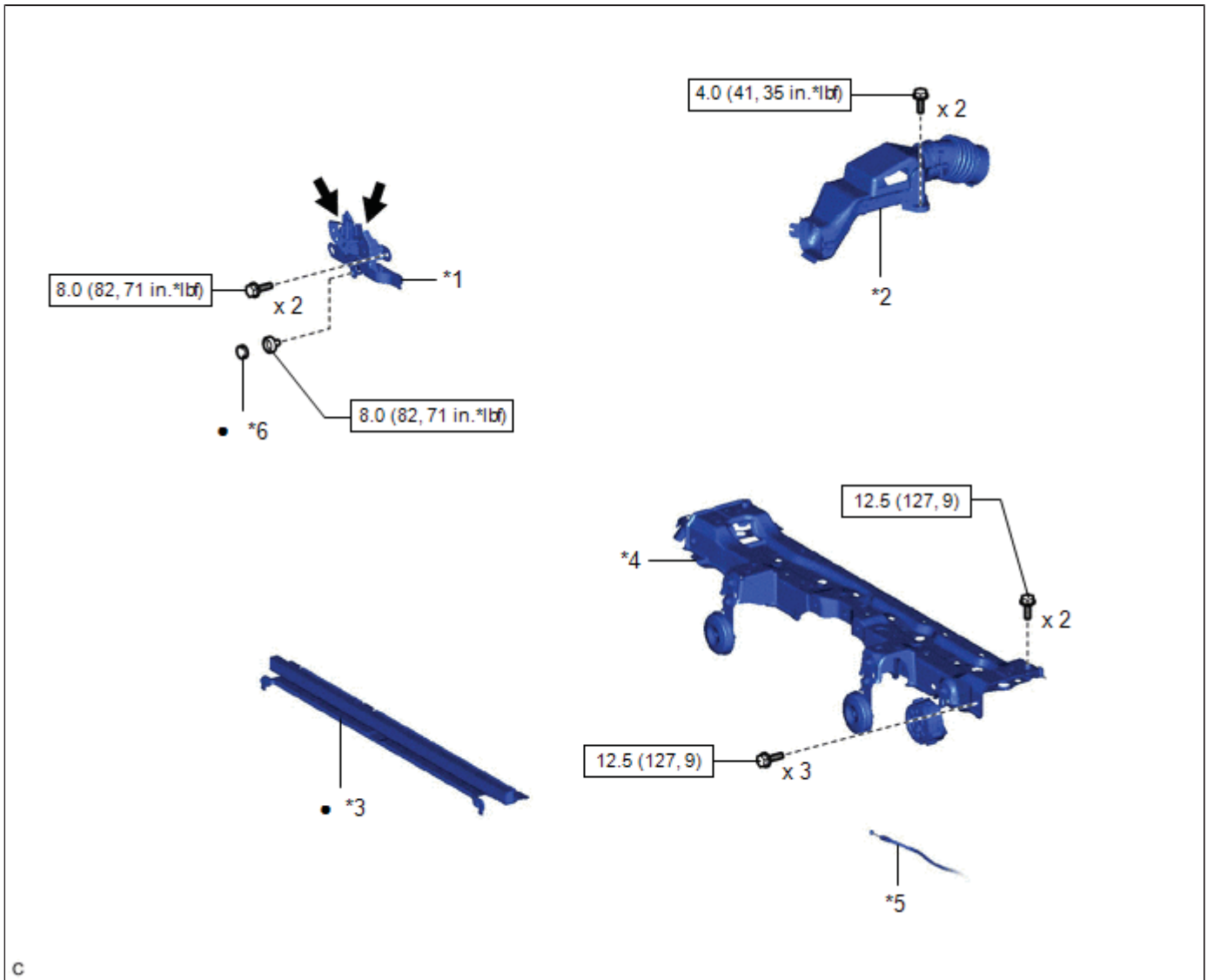

| | | | |
|---|---|---|---|
| *1 | NO. 1 ENGINE UNDER COVER | - | - |
|  | N*m (kgf*cm, ft.*lbf): Specified torque | - | - |

ILLUSTRATION



c

| | | | |
|---|---|----|-------------------------------------|
| *1 | HOOD LOCK ASSEMBLY | *2 | NO. 2 INLET AIR CLEANER |
| *3 | NO. 2 RADIATOR AIR GUIDE | *4 | UPPER RADIATOR SUPPORT SUB-ASSEMBLY |
| *5 | HOOD LOCK CONTROL CABLE ASSEMBLY | *6 | HOOD LOCK NUT CAP |
|  | N*m (kgf*cm, ft.*lbf): Specified torque | • | Non-reusable part |
|  | MP grease | - | - |

ILLUSTRATION

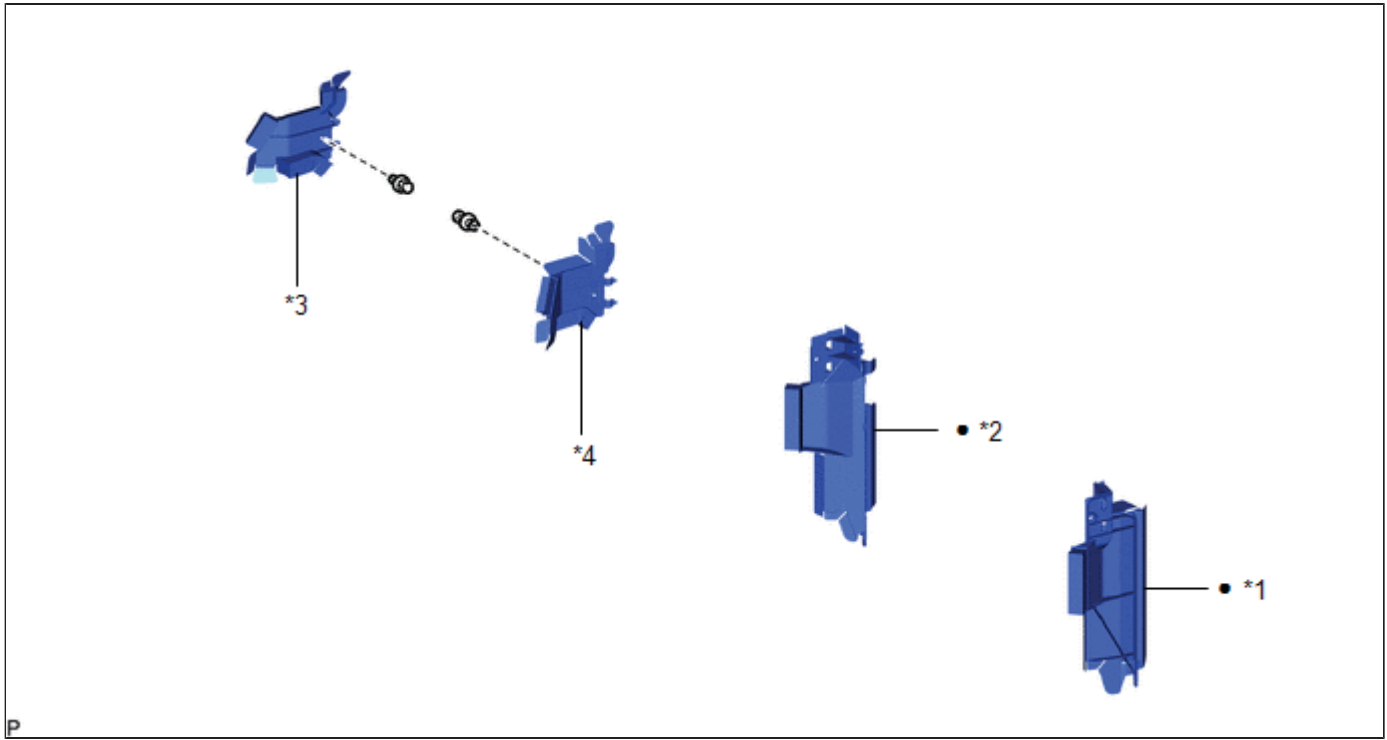

| | | | |
|----|--------------------------------|----|--------------------------------|
| *1 | RADIATOR AIR GUIDE LH | *2 | RADIATOR AIR GUIDE RH |
| *3 | NO. 2 RADIATOR TO SUPPORT SEAL | *4 | NO. 3 RADIATOR TO SUPPORT SEAL |
| • | Non-reusable part | - | - |

ILLUSTRATION

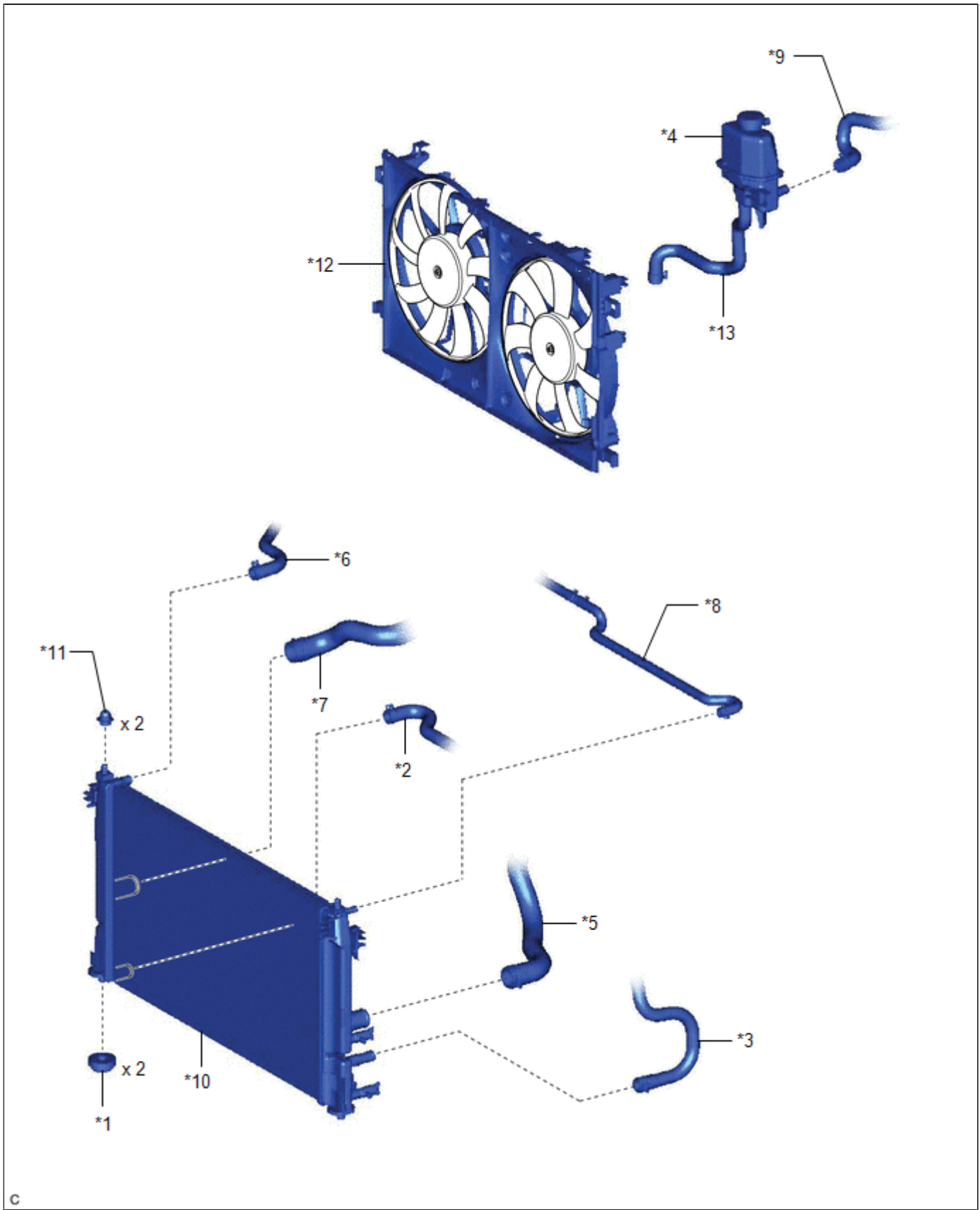

| | | | |
|----|-----------------------------------|----|--------------------------------|
| *1 | RADIATOR SUPPORT GROMMET | *2 | INLET HYBRID RADIATOR HOSE |
| *3 | INLET NO. 1 INVERTER COOLING HOSE | *4 | INVERTER RESERVE TANK ASSEMBLY |
| | | | |

| | | | |
|-----|------------------------------------|-----|--------------------------|
| *5 | NO. 1 RADIATOR HOSE | *6 | NO. 1 WATER BY-PASS HOSE |
| *7 | NO. 2 RADIATOR HOSE | *8 | NO. 2 WATER BY-PASS HOSE |
| *9 | OUTLET NO. 1 INVERTER COOLING HOSE | *10 | RADIATOR ASSEMBLY |
| *11 | RADIATOR SUPPORT CUSHION | *12 | FAN SHROUD ASSEMBLY |
| *13 | INLET HYBRID WATER PUMP HOSE | - | - |

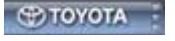

| | | |
|--|---------------------|--------------------------------------|
| Last Modified: 01-14-2019 | 6.8:8.0.48 | Doc ID: RM100000000TC4W |
| Model Year Start: 2016 | Model: Prius | Prod Date Range: [11/2015 -] |
| Title: 2ZR-FXE (COOLING): RADIATOR: INSTALLATION; 2016 - 2019 MY Prius [11/2015 -] | | |

INSTALLATION

PROCEDURE

1. INSTALL RADIATOR SUPPORT GROMMET

- (a) Install the 2 radiator support grommets to the radiator assembly.

2. INSTALL RADIATOR SUPPORT CUSHION

- (a) Install the 2 radiator support cushions to the radiator assembly.

3. INSTALL RADIATOR ASSEMBLY

- (a) Engage the 2 guides.
- (b) Engage the 2 claws to install the fan shroud assembly to the radiator assembly.

NOTICE:

Do not damage the radiator assembly when installing the fan shroud assembly.

- (c) Install the radiator assembly with the fan shroud assembly to the vehicle body.

NOTICE:

Do not apply excessive force to the cooler condenser assembly or pipe when installing the radiator assembly with the fan shroud assembly.

- (d) Engage the 2 guides.
- (e) Engage the 2 claws to install the cooler condenser assembly to the radiator assembly.

NOTICE:

Make sure not to damage the cooler condenser assembly when installing the radiator assembly.

4. INSTALL INVERTER RESERVE TANK ASSEMBLY

- (a) Engage the clamp to connect the inlet hybrid water pump hose to the fan shroud assembly.
- (b) Engage the 2 claws to install the inverter reserve tank assembly to the fan shroud assembly.

5. CONNECT OUTLET NO. 1 INVERTER COOLING HOSE

- (a) Connect the outlet No. 1 inverter cooling hose and slide the clip to secure it.

6. CONNECT NO. 1 RADIATOR HOSE

- (a) Connect the No. 1 radiator hose and slide the clip to secure it.

7. CONNECT NO. 2 RADIATOR HOSE

- (a) Connect the No. 2 radiator hose and slide the clip to secure it.

8. CONNECT INLET NO. 1 INVERTER COOLING HOSE

- (a) Connect the inlet No. 1 inverter cooling hose and slide the clip to secure it.
- (b) Engage the 3 clamps to connect the wire harness to the fan shroud assembly.

9. CONNECT INLET HYBRID RADIATOR HOSE

- (a) Connect the inlet hybrid radiator hose and slide the clip to secure it.

(b) Engage the clamp to connect the inlet hybrid radiator hose to the fan shroud assembly.

10. CONNECT NO. 2 WATER BY-PASS HOSE

(a) Connect the No. 2 water by-pass hose and slide the clip to secure it.

(b) Engage the 4 clamps.

11. CONNECT NO. 1 WATER BY-PASS HOSE

(a) Connect the No. 1 water by-pass hose and slide the clip to secure it.

12. INSTALL NO. 1 RADIATOR AIR GUIDE LH

Click here [INFO](#)

13. INSTALL NO. 1 RADIATOR AIR GUIDE RH

Click here [INFO](#)

14. INSTALL NO. 2 RADIATOR AIR GUIDE

(a) Engage the 5 claws to install a new No. 2 radiator air guide to the radiator assembly.

15. INSTALL UPPER RADIATOR SUPPORT SUB-ASSEMBLY

(a) Install the upper radiator support sub-assembly with the 5 bolts.

Torque:

12.5 N·m { 127 kgf·cm, 9 ft·lbf }

(b) Engage the clamp to connect the hood lock control cable assembly to the upper radiator support sub-assembly.

(c) Connect the cooling fan motor RH connector and cooling fan motor LH connector.

(d) Engage the 7 clamps to connect the wire harness to the upper radiator support sub-assembly and fan shroud assembly.

(e) w/o Vehicle Approaching Speaker Assembly:

(1) Connect the 2 horn connectors.

(f) w/ Vehicle Approaching Speaker Assembly:

(1) Connect the 2 horn connectors and vehicle approaching speaker assembly connector.

16. INSTALL INLET NO. 2 AIR CLEANER

Click here [INFO](#)

17. INSTALL HOOD LOCK ASSEMBLY

Click here [INFO](#) [INFO](#)

18. INSTALL INVERTER WATER PUMP ASSEMBLY

Click here [INFO](#)

19. INSTALL HEADLIGHT ASSEMBLY LH

Click here [INFO](#) [INFO](#)

20. INSTALL HEADLIGHT ASSEMBLY RH

HINT:

Use the same procedure as for the LH side.

21. ADD ENGINE COOLANT (for Engine)

Click here [INFO](#) [INFO](#)

22. INSPECT FOR COOLANT LEAK (for Engine)

Click here [INFO](#) [INFO](#)

23. INSTALL NO. 1 ENGINE UNDER COVER

Click here [INFO](#) [INFO](#) [INFO](#)

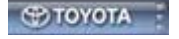

| | | |
|--|--------------|--------------------------------------|
| Last Modified: 01-14-2019 | 6.8:8.0.48 | Doc ID: RM100000000TC4U |
| Model Year Start: 2016 | Model: Prius | Prod Date Range: [11/2015 - 08/2016] |
| Title: 2ZR-FXE (COOLING): RADIATOR: ON-VEHICLE INSPECTION; 2016 MY Prius [11/2015 - 08/2016] | | |

ON-VEHICLE INSPECTION

CAUTION / NOTICE / HINT

CAUTION:

Do not remove the reserve tank cap, air release valve (w/ air release valve) or radiator drain cock plug while the engine and radiator assembly are still hot. Pressurized, hot engine coolant and steam may be released and cause serious burns.

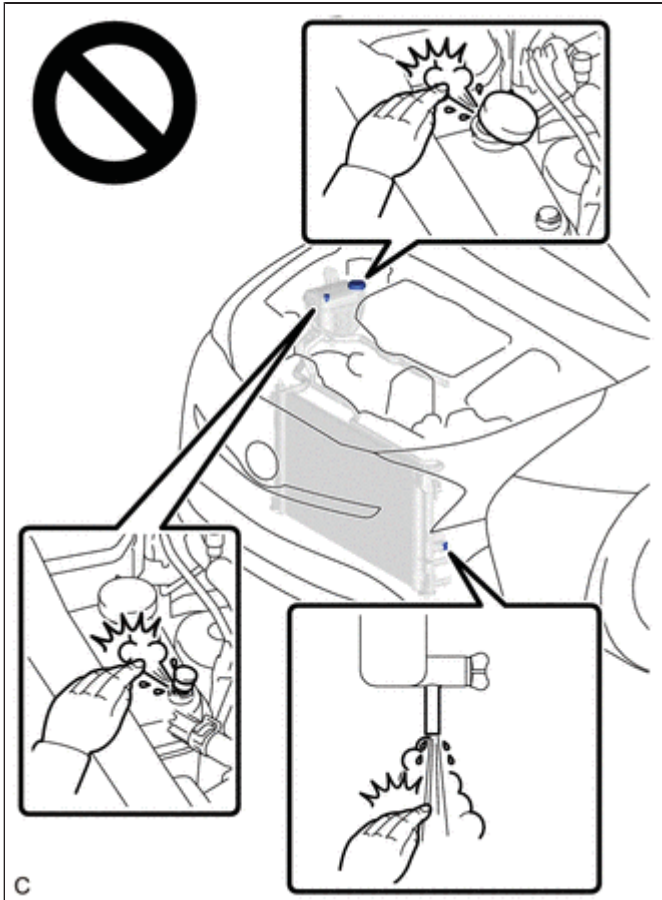

PROCEDURE

1. INSPECT RESERVE TANK CAP (for Engine)

CAUTION:

Do not remove the reserve tank cap, air release valve (w/ air release valve) or radiator drain cock plug while the engine and radiator assembly are still hot. Pressurized, hot engine coolant and steam may be released and cause serious burns.

- (a) Measure the valve opening pressure.

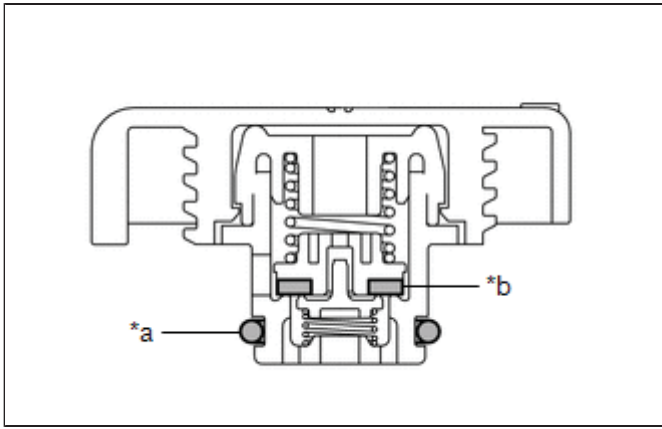

| | |
|----|----------------|
| *a | O-ring |
| *b | Rubber Packing |

- (1) If there are water stains or foreign matter on the O-ring, clean it with water and finger scouring.
- (2) Check that the O-ring is not deformed, cracked or swollen.
- (3) Apply engine coolant to the O-ring and rubber packing before using a radiator cap tester.

- (4) When using the radiator cap tester, tilt it upwards 30° or more.

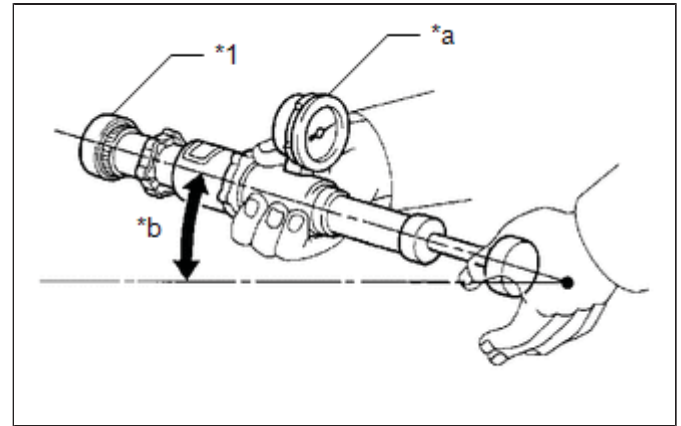

| | |
|----|---------------------|
| *1 | Reserve Tank Cap |
| *a | Radiator Cap Tester |
| *b | 30° or more |

- (5) Pump the radiator cap tester several times, and check the maximum pressure.

Pump Speed:

1 pump per second

HINT:

Even if the reserve tank cap cannot maintain the maximum pressure, it is not a defect.

| ITEM | SPECIFIED CONDITION |
|---|--------------------------------|
| Standard pressure (for brand-new reserve tank cap) | 94 to 122 kPa |
| Standard pressure (for brand-new reserve tank cap) | 1.0 to 1.2 kgf/cm ² |
| Standard pressure | |

| | |
|---|-------------------------|
| (for brand-new reserve tank cap) | 13.5 to 17 psi |
| Minimum pressure (for used reserve tank cap) | 79 kPa |
| Minimum pressure (for used reserve tank cap) | 0.8 kgf/cm ² |
| Minimum pressure (for used reserve tank cap) | 11.4 psi |

If the maximum pressure is less than the minimum pressure, replace the reserve tank cap.

2. INSPECT FINS FOR BLOCKAGE

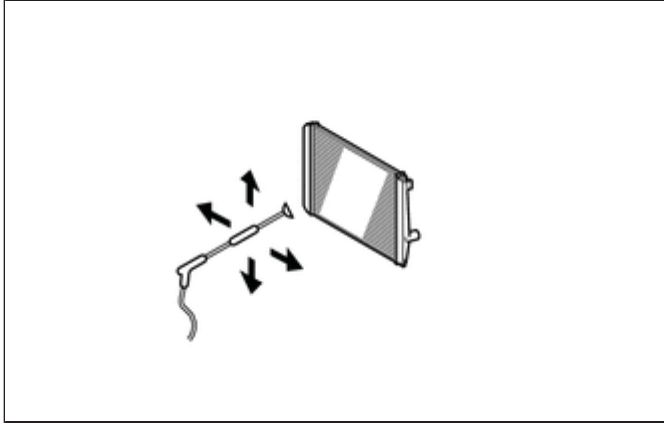

(a) If the fins are clogged, wash them with water or a steam cleaner and dry them with compressed air.

NOTICE:

- To avoid damaging the fins, keep the tip of the nozzle at right angles to the core surface.
- If the nozzle of the steam cleaner is too close to the core, there is a possibility of damaging the fins. Always maintain the following distances from the core when using a steam cleaner.

Standard Steam Cleaner Nozzle Distance

| STEAM PRESSURE | SPECIFIED CONDITION |
|---|---------------------|
| 2942 to 4903 kPa (30.0 to 50.0 kgf/cm ² , 427 to 711 psi) | 300 mm (11.8 in.) |
| 4903 to 7845 kPa (50.0 to 80.0 kgf/cm ² , 711 to 1138 psi) | 500 mm (19.7 in.) |

- If the fins are bent, straighten them with a screwdriver or pliers.
- Do not expose electronic components to water.

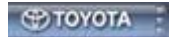

| | | |
|---|---------------------|--------------------------------------|
| Last Modified: 01-14-2019 | 6.8:8.0.48 | Doc ID: RM100000000TC4V |
| Model Year Start: 2016 | Model: Prius | Prod Date Range: [11/2015 -] |
| Title: 2ZR-FXE (COOLING): RADIATOR: REMOVAL; 2016 - 2019 MY Prius [11/2015 -] | | |

REMOVAL

CAUTION / NOTICE / HINT

The necessary procedures (adjustment, calibration, initialization, or registration) that must be performed after parts are removed and installed, or replaced during radiator assembly removal/installation are shown below.

Necessary Procedure After Parts Removed/Installed/Replaced

| REPLACED PART OR PERFORMED PROCEDURE | NECESSARY PROCEDURE | EFFECT/INOPERATIVE FUNCTION WHEN NECESSARY PROCEDURE NOT PERFORMED | LINK |
|--------------------------------------|---|---|--|
| Front bumper assembly | <ul style="list-style-type: none"> Ultrasonic sensor detection angle (w/ Intuitive Parking Assist System) Ultrasonic sensor detection angle registration (w/ Intuitive Parking Assist System) | <ul style="list-style-type: none"> Intelligent clearance sonar system Simple advanced parking guidance system | INFO INFO |
| | Change grille shutter control mode and/or perform initialization | Grille Shutter system | INFO |

PROCEDURE

1. REMOVE HEADLIGHT ASSEMBLY LH

Click here [INFO](#) [INFO](#)

2. REMOVE HEADLIGHT ASSEMBLY RH

HINT:

Use the same procedure as for the LH side.

3. REMOVE NO. 1 ENGINE UNDER COVER

Click here [INFO](#) [INFO](#) [INFO](#)

4. DRAIN ENGINE COOLANT (for Engine)

Click here [INFO](#) [INFO](#)

5. REMOVE INVERTER WATER PUMP ASSEMBLY

Click here [INFO](#)

6. REMOVE HOOD LOCK ASSEMBLY

Click here [INFO](#) [INFO](#)

7. REMOVE INLET NO. 2 AIR CLEANER

Click here [INFO](#)

8. REMOVE UPPER RADIATOR SUPPORT SUB-ASSEMBLY

(a) w/o Vehicle Approaching Speaker Assembly:

(1) Disconnect the 2 horn connectors.

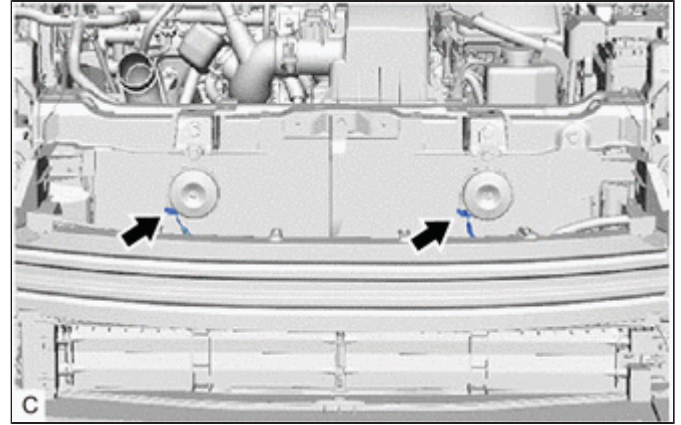

(b) w/ Vehicle Approaching Speaker Assembly:

(1) Disconnect the 2 horn connectors and vehicle approaching speaker assembly connector.

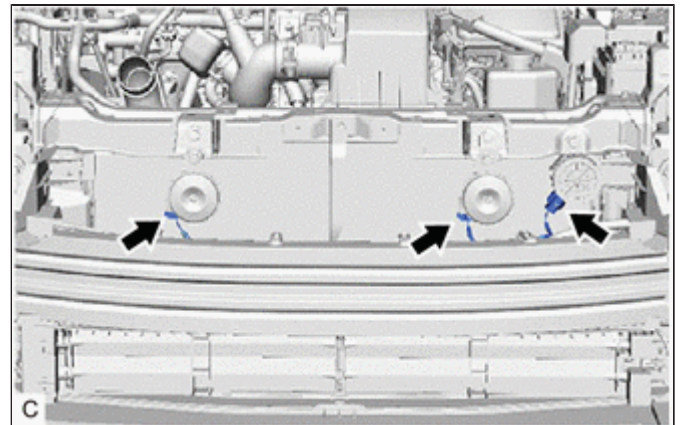

(c) Disengage the 7 clamps to disconnect the wire harness from the upper radiator support sub-assembly and fan shroud assembly.

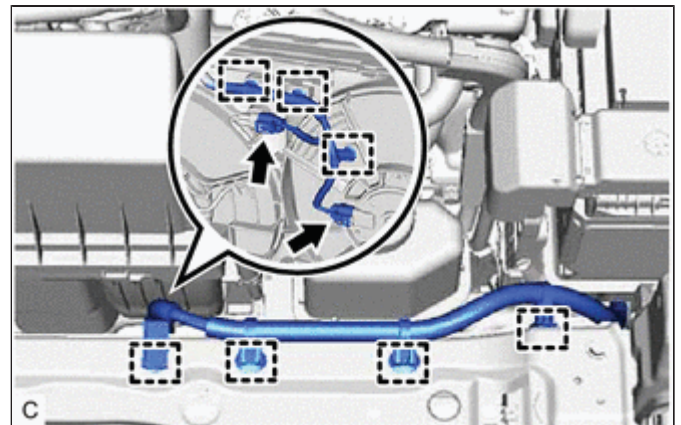

(d) Disconnect the cooling fan motor RH connector and cooling fan motor LH connector.

(e) Disengage the clamp to disconnect the hood lock control cable assembly from the upper radiator support sub-assembly.

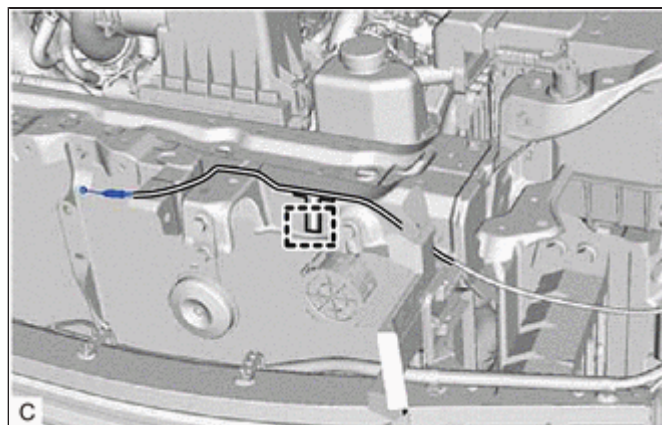

(f) Remove the 5 bolts and upper radiator support sub-assembly.

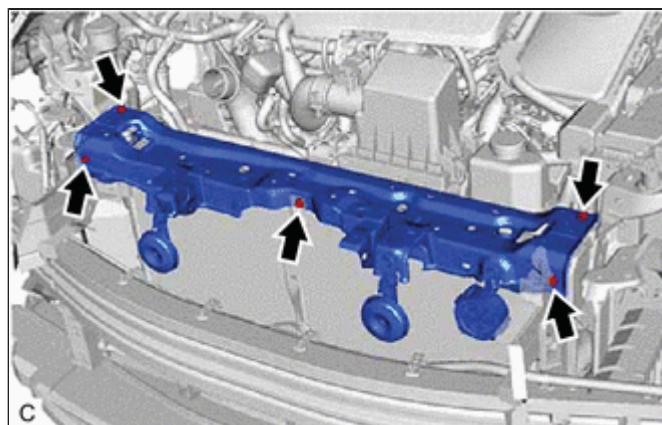

9. REMOVE NO. 2 RADIATOR AIR GUIDE

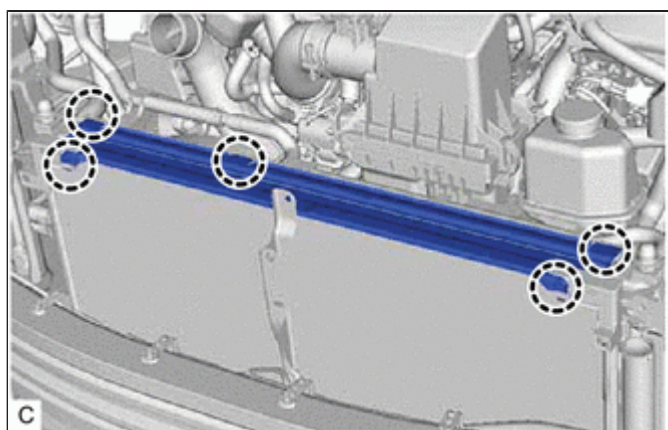

(a) Disengage the 5 claws to remove the No. 2 radiator air guide from the radiator assembly.

10. REMOVE NO. 1 RADIATOR AIR GUIDE LH

Click here [INFO](#)

11. REMOVE NO. 1 RADIATOR AIR GUIDE RH

Click here [INFO](#)

12. DISCONNECT NO. 1 WATER BY-PASS HOSE

(a) Slide the clip and disconnect the No. 1 water by-pass hose.

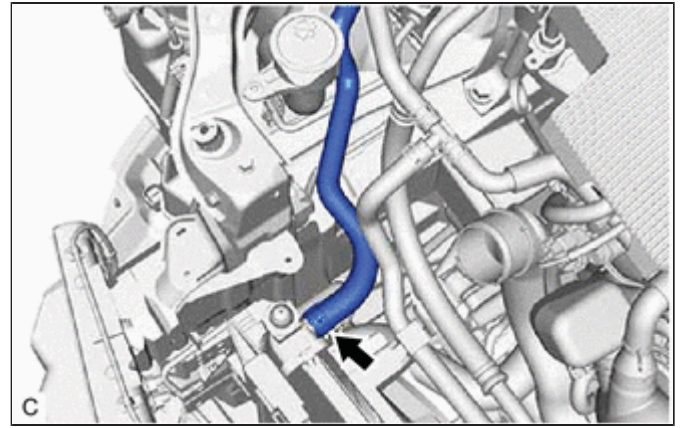

13. DISCONNECT NO. 2 WATER BY-PASS HOSE

(a) Disengage the 4 clamps.

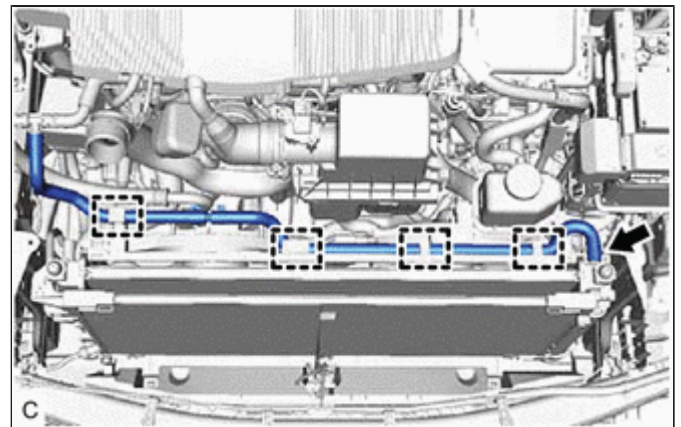

(b) Slide the clip and disconnect the No. 2 water by-pass hose.

14. DISCONNECT INLET HYBRID RADIATOR HOSE

(a) Disengage the clamp to disconnect the inlet hybrid radiator hose from the fan shroud assembly.

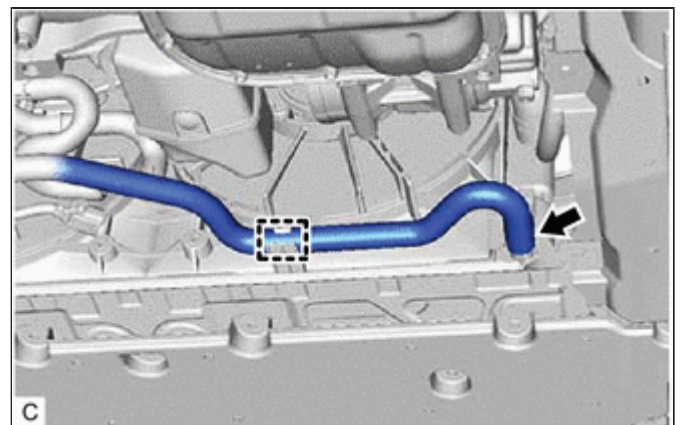

(b) Slide the clip and disconnect the inlet hybrid radiator hose.

15. DISCONNECT INLET NO. 1 INVERTER COOLING HOSE

- (a) Disengage the 3 clamps to disconnect the wire harness from the fan shroud assembly.

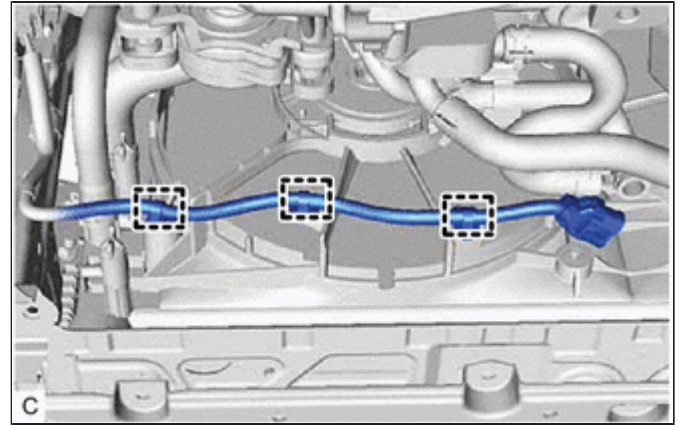

- (b) Slide the clip and disconnect the inlet No. 1 inverter cooling hose.

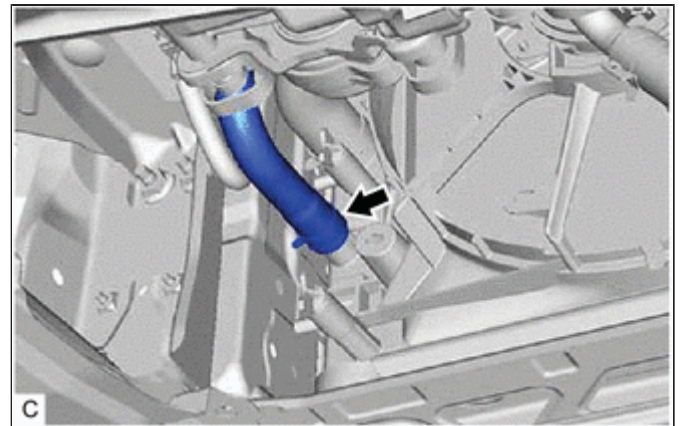

16. DISCONNECT NO. 2 RADIATOR HOSE

- (a) Slide the clip and disconnect the No. 2 radiator hose.

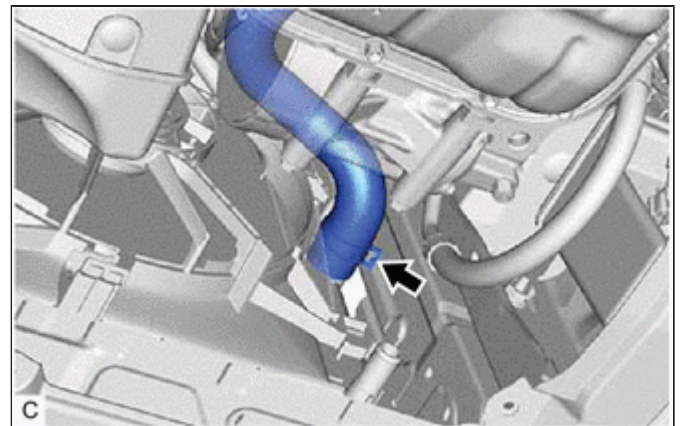

17. DISCONNECT NO. 1 RADIATOR HOSE

(a) Slide the clip and disconnect the No. 1 radiator hose.

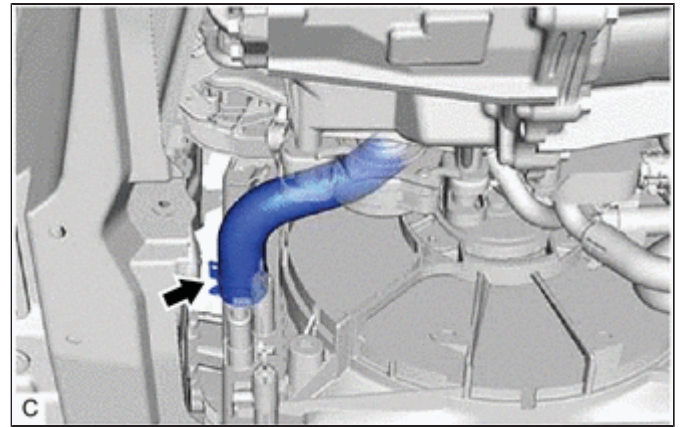

18. DISCONNECT OUTLET NO. 1 INVERTER COOLING HOSE

(a) Slide the clip and disconnect the outlet No. 1 inverter cooling hose.

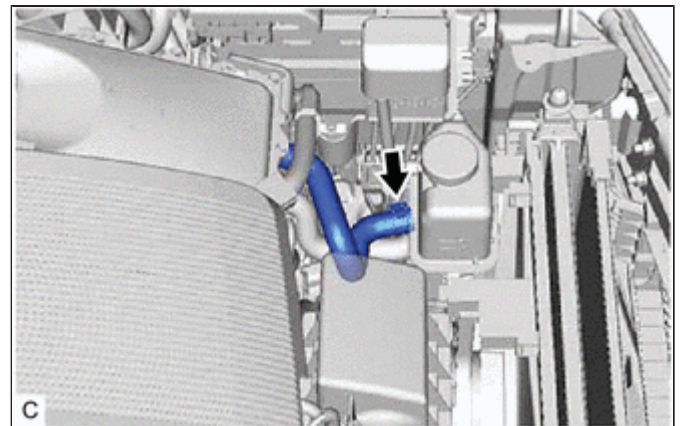

19. REMOVE INVERTER RESERVE TANK ASSEMBLY

(a) Disengage the clamp to disconnect the inlet hybrid water pump hose from the fan shroud assembly.

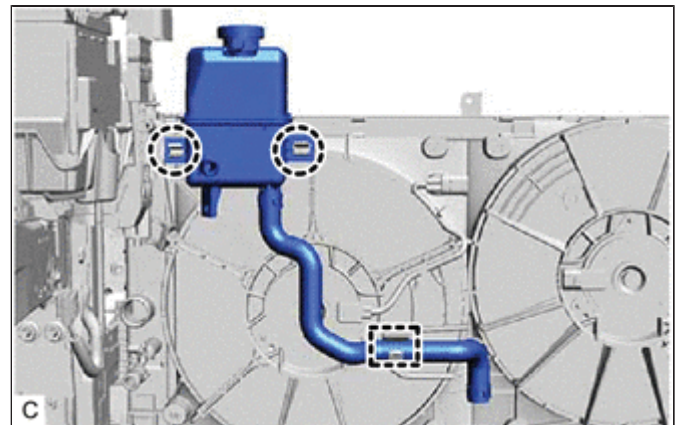

(b) Disengage the 2 claws to remove the inverter reserve tank assembly from the fan shroud assembly.

20. REMOVE RADIATOR ASSEMBLY

(a) Disengage the 2 claws.

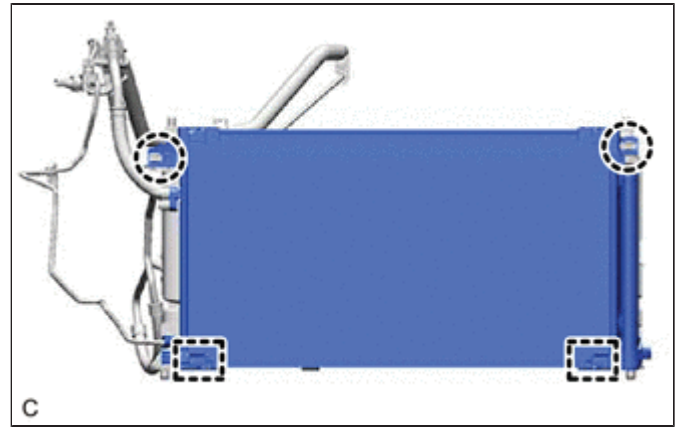

(b) Disengage the 2 guides to separate the cooler condenser assembly from the radiator assembly.

NOTICE:

Make sure not to damage the cooler condenser assembly when removing the radiator assembly.

(c) Remove the radiator assembly with the fan shroud assembly from the vehicle body.

NOTICE:

Do not apply excessive force to the cooler condenser assembly or pipe when removing the radiator assembly with the fan shroud assembly.

(d) Disengage the 2 claws.

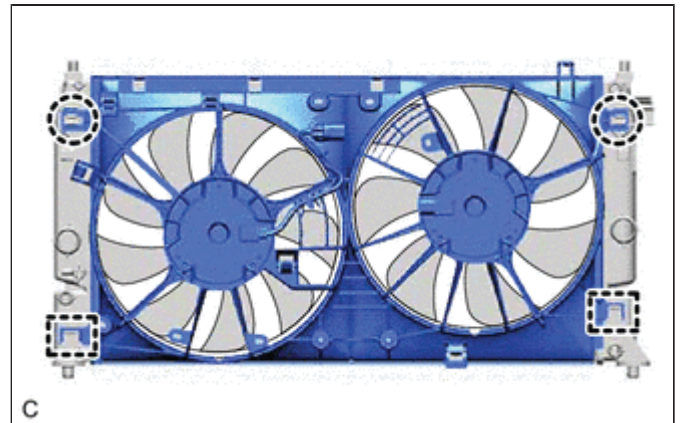

(e) Disengage the 2 guides to remove the fan shroud assembly from the radiator assembly.

NOTICE:

Do not damage the radiator assembly when removing the fan shroud assembly.

21. REMOVE RADIATOR SUPPORT CUSHION

(a) Remove the 2 radiator support cushions from the radiator assembly.

22. REMOVE RADIATOR SUPPORT GROMMET

(a) Remove the 2 radiator support grommets from the radiator assembly.

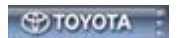

| | | |
|---|--------------|-------------------------------|
| Last Modified: 01-14-2019 | 6.8:8.0.48 | Doc ID: RM100000000TC4X |
| Model Year Start: 2016 | Model: Prius | Prod Date Range: [11/2015 -] |
| Title: 2ZR-FXE (COOLING): RELAY: ON-VEHICLE INSPECTION; 2016 - 2019 MY Prius [11/2015 -] | | |

ON-VEHICLE INSPECTION

PROCEDURE

1. INSPECT FAN NO. 1 RELAY

(a) Measure the resistance according to the value(s) in the table below.

Standard Resistance:

| TESTER CONNECTION | CONDITION | SPECIFIED CONDITION |
|-------------------|---|-------------------------|
| 3 - 5 | Auxiliary battery voltage not applied between terminals 1 and 2 | 10 k Ω or higher |
| 3 - 5 | Auxiliary battery voltage applied between terminals 1 and 2 | Below 1 Ω |

If the result is not as specified, replace the FAN NO. 1 relay.

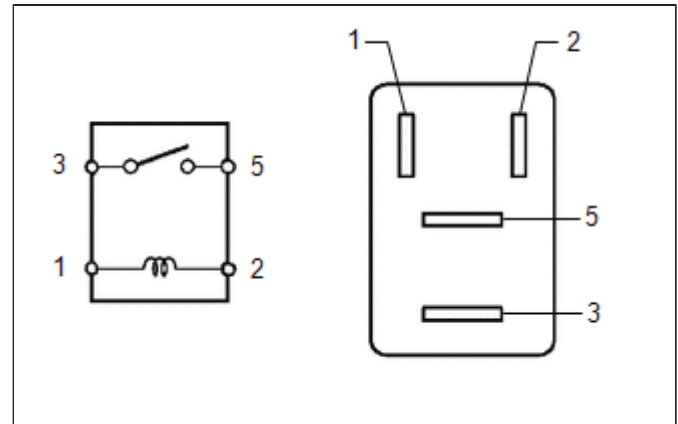

2. INSPECT FAN NO. 2 RELAY

(a) Measure the resistance according to the value(s) in the table below.

Standard Resistance:

| TESTER CONNECTION | CONDITION | SPECIFIED CONDITION |
|-------------------|---|-------------------------|
| 3 - 4 | Auxiliary battery voltage not applied between terminals 1 and 2 | Below 1 Ω |
| 3 - 4 | Auxiliary battery voltage applied between terminals 1 and 2 | 10 k Ω or higher |
| 3 - 5 | Auxiliary battery voltage not applied between terminals 1 and 2 | 10 k Ω or higher |
| 3 - 5 | Auxiliary battery voltage applied between terminals 1 and 2 | Below 1 Ω |

If the result is not as specified, replace the FAN NO. 2 relay.

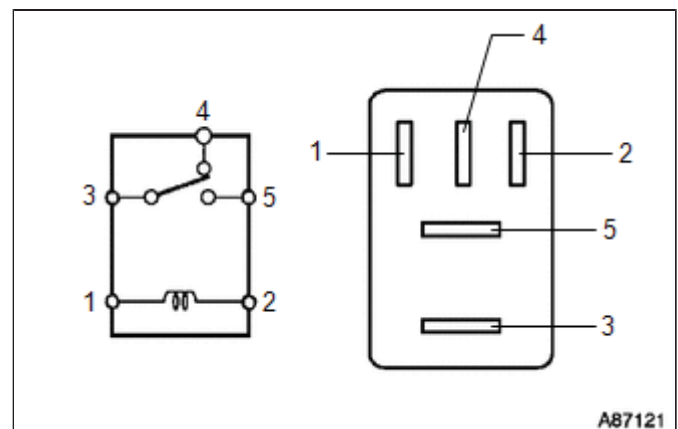

3. INSPECT FAN NO. 3 RELAY

(a) Measure the resistance according to the value(s) in the table below.

Standard Resistance:

| TESTER CONNECTION | CONDITION | SPECIFIED CONDITION |
|-------------------|---|-------------------------|
| 3 - 5 | Auxiliary battery voltage not applied between terminals 1 and 2 | 10 k Ω or higher |
| 3 - 5 | Auxiliary battery voltage applied between terminals 1 and 2 | Below 1 Ω |

If the result is not as specified, replace the FAN NO. 3 relay.

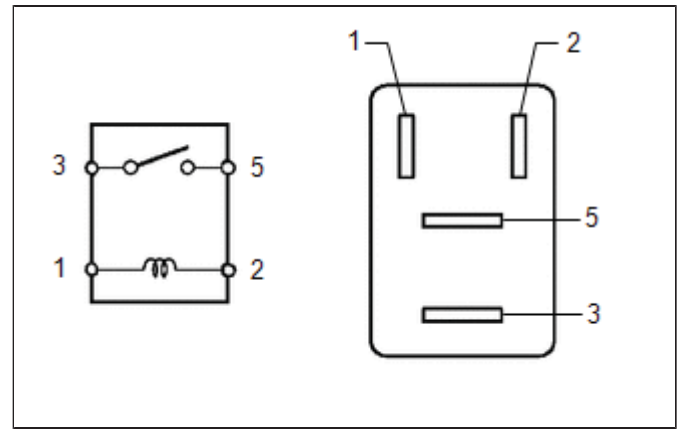

| | | |
|---|--------------|-------------------------------|
| Last Modified: 01-14-2019 | 6.8:8.0.48 | Doc ID: RM100000000TJ53 |
| Model Year Start: 2016 | Model: Prius | Prod Date Range: [11/2015 -] |
| Title: 2ZR-FXE (COOLING): TEMPERATURE SWITCH: COMPONENTS; 2016 - 2019 MY Prius [11/2015 -] | | |

COMPONENTS

ILLUSTRATION

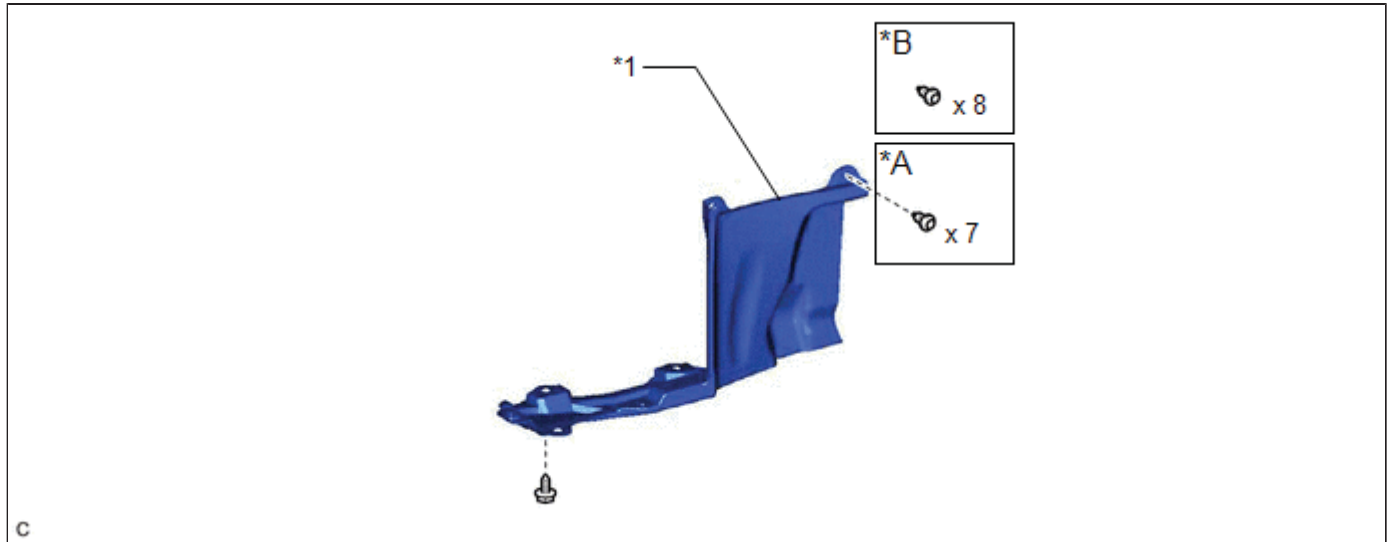

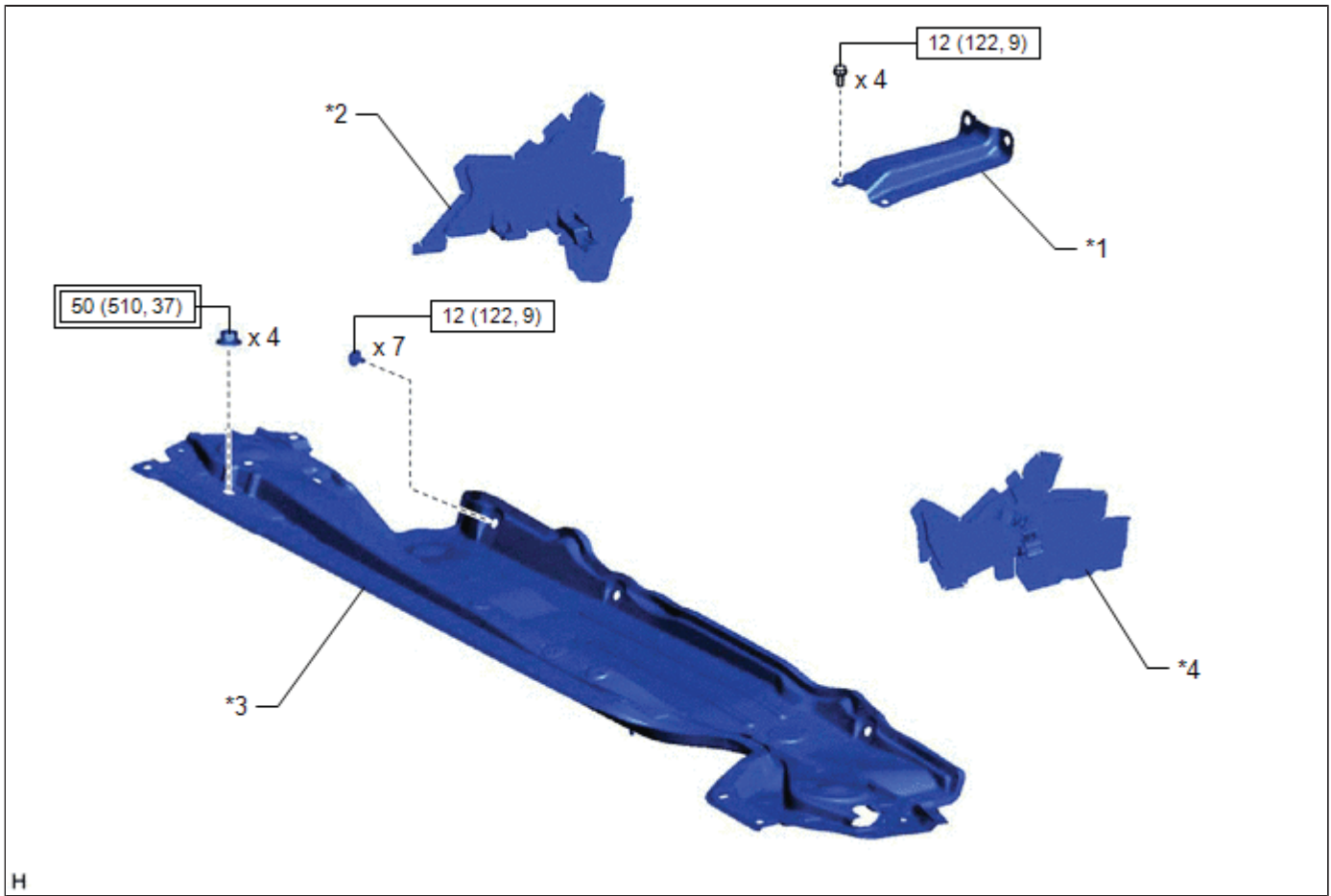

| | | | |
|----|---|----|--|
| *A | except Rough Road Area Specification Vehicles | *B | for Rough Road Area Specification Vehicles |
| *1 | REAR MOTOR UNDER COVER LH | - | - |

ILLUSTRATION



H

| | | | |
|---|--|---|--|
| *1 | COWL BODY MOUNTING REINFORCEMENT LH | *2 | NO. 1 HEATER AIR DUCT SPLASH SHIELD SEAL |
| *3 | OUTER COWL TOP PANEL SUB-ASSEMBLY | *4 | WATER GUARD PLATE LH |
|  | Tightening torque for "Major areas involving basic vehicle performance such as moving/turning/stopping" : N*m (kgf*cm, ft.*lbf) |  | N*m (kgf*cm, ft.*lbf): Specified torque |

ILLUSTRATION

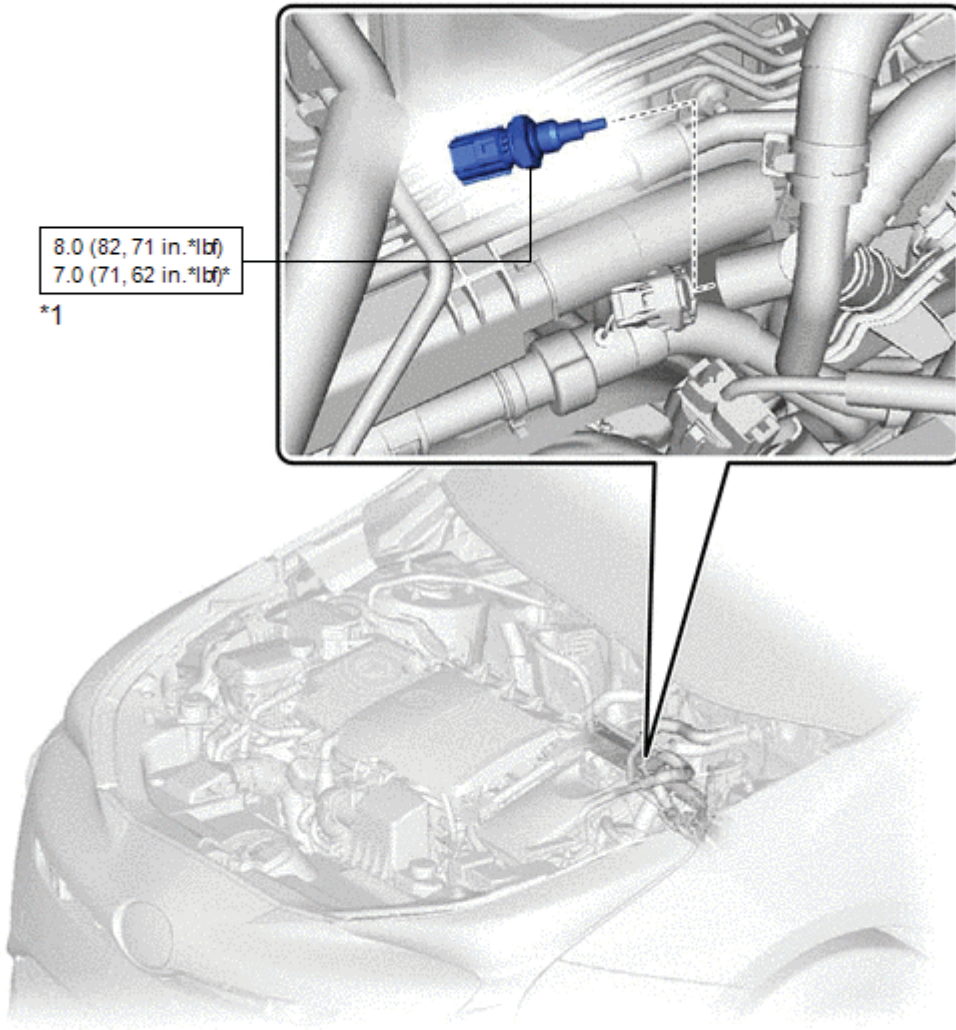

8.0 (82, 71 in.*lbf)
7.0 (71, 62 in.*lbf)*
*1

C

| | | | |
|----|---|---|---------------------------------------|
| *1 | ENGINE COOLANT TEMPERATURE SENSOR | - | - |
| | N*m (kgf*cm, ft.*lbf): Specified torque | * | For use with a 19 mm union nut wrench |

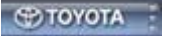

| | | |
|---|--------------|-------------------------------|
| Last Modified: 01-14-2019 | 6.8:8.0.48 | Doc ID: RM100000000TJ52 |
| Model Year Start: 2016 | Model: Prius | Prod Date Range: [11/2015 -] |
| Title: 2ZR-FXE (COOLING): TEMPERATURE SWITCH: INSPECTION; 2016 - 2019 MY Prius [11/2015 -] | | |

INSPECTION

PROCEDURE

1. INSPECT ENGINE COOLANT TEMPERATURE SENSOR

(a) Measure the resistance according to the value(s) in the table below.

Standard Resistance:



[Click Location & Routing\(A10\)](#)

[Click Connector\(A10\)](#)

| TESTER CONNECTION | CONDITION | SPECIFIED CONDITION |
|---------------------------|----------------------------|---------------------|
| A10-1 (E2) - A10-2 (TSW3) | Approximately 20°C (68°F) | 2.32 to 2.59 kΩ |
| A10-1 (E2) - A10-2 (TSW3) | Approximately 80°C (176°F) | 0.310 to 0.326 kΩ |

NOTICE:

When checking the engine coolant temperature sensor in water, keep the terminals dry. After the check, dry the engine coolant temperature sensor.

If the result is not as specified, replace the engine coolant temperature sensor.

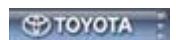
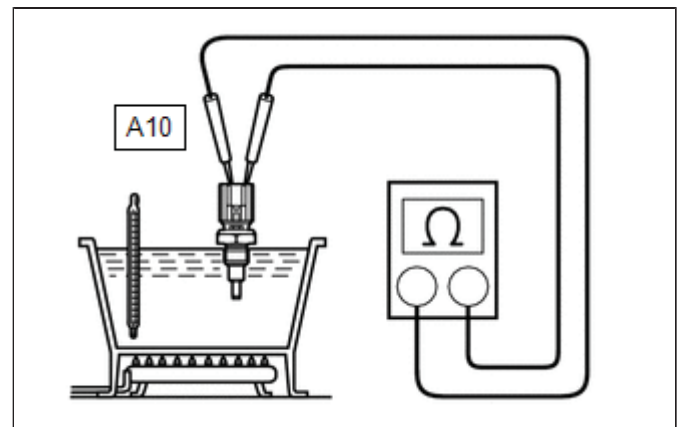

| | | |
|---|--------------|-------------------------------|
| Last Modified: 01-14-2019 | 6.8:8.0.48 | Doc ID: RM100000000TJ51 |
| Model Year Start: 2016 | Model: Prius | Prod Date Range: [11/2015 -] |
| Title: 2ZR-FXE (COOLING): TEMPERATURE SWITCH: INSTALLATION; 2016 - 2019 MY Prius [11/2015 -] | | |

INSTALLATION

PROCEDURE

1. INSTALL ENGINE COOLANT TEMPERATURE SENSOR

(a) Using a 19 mm union nut wrench, install the engine coolant temperature sensor to the No. 2 water joint.

Torque:

Specified tightening torque :

8.0 N·m {82 kgf·cm, 71 in·lbf}

NOTICE:

Do not apply any excessive force to the heater pipe when installing the engine coolant temperature sensor.

HINT:

- Calculate the torque wrench reading when changing the fulcrum length of the torque wrench.

Click here [INFO](#) [INFO](#) [INFO](#)

- When using a 19 mm union nut wrench (fulcrum length of 30.0 mm (1.18 in.)) + torque wrench (fulcrum length of 155 mm (6.10 in.)): 7.0 N*m (71 kgf*cm, 62 in.*lbf)

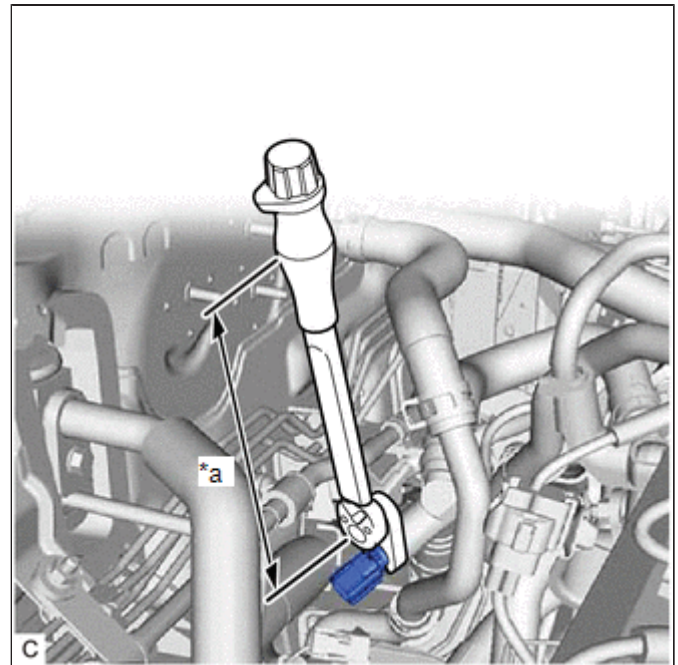

| | |
|----|------------------------------|
| *a | Torque Wrench Fulcrum Length |
|----|------------------------------|

(b) Connect the engine coolant temperature sensor connector.

2. INSTALL OUTER COWL TOP PANEL SUB-ASSEMBLY

Click here [INFO](#) [INFO](#)

3. INSTALL COWL BODY MOUNTING REINFORCEMENT LH

Click here [INFO](#) [INFO](#)

4. INSTALL WATER GUARD PLATE LH

Click here [INFO](#) [INFO](#)

5. INSTALL NO. 1 HEATER AIR DUCT SPLASH SHIELD SEAL

Click here [INFO](#) [INFO](#)

6. INSTALL WINDSHIELD WIPER MOTOR AND LINK ASSEMBLY

Click here [INFO](#)

7. ADD ENGINE COOLANT (for Engine)

Click here [INFO](#) [INFO](#)

8. INSPECT FOR COOLANT LEAK (for Engine)

Click here [INFO](#) [INFO](#)

9. INSTALL REAR MOTOR UNDER COVER LH

Click here [INFO](#)

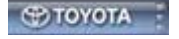

| | | |
|---|---------------------|--------------------------------------|
| Last Modified: 01-14-2019 | 6.8:8.0.48 | Doc ID: RM100000000TJ54 |
| Model Year Start: 2016 | Model: Prius | Prod Date Range: [11/2015 -] |
| Title: 2ZR-FXE (COOLING): TEMPERATURE SWITCH: REMOVAL; 2016 - 2019 MY Prius [11/2015 -] | | |

REMOVAL

PROCEDURE

1. REMOVE REAR MOTOR UNDER COVER LH

Click here [INFO](#)

2. DRAIN ENGINE COOLANT (for Engine)

Click here [INFO](#) [INFO](#)

3. REMOVE WINDSHIELD WIPER MOTOR AND LINK ASSEMBLY

Click here [INFO](#)

4. REMOVE NO. 1 HEATER AIR DUCT SPLASH SHIELD SEAL

Click here [INFO](#) [INFO](#)

5. REMOVE WATER GUARD PLATE LH

Click here [INFO](#) [INFO](#)

6. REMOVE COWL BODY MOUNTING REINFORCEMENT LH

Click here [INFO](#) [INFO](#)

7. REMOVE OUTER COWL TOP PANEL SUB-ASSEMBLY

Click here [INFO](#) [INFO](#)

8. REMOVE ENGINE COOLANT TEMPERATURE SENSOR

(a) Disconnect the engine coolant temperature sensor connector.

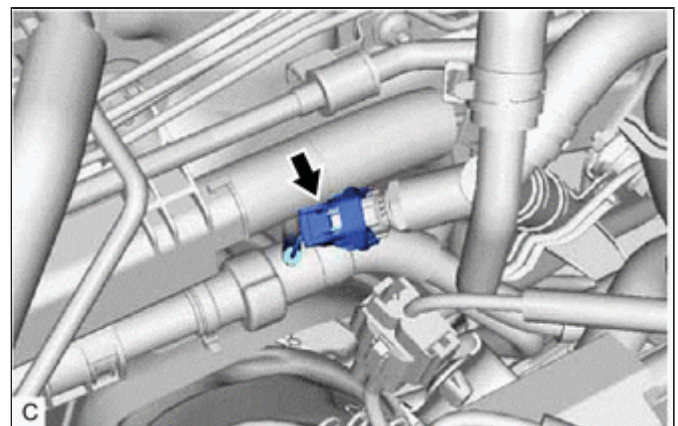

(b) Using a 19 mm union nut wrench, remove the engine coolant temperature sensor from the No. 2 water joint.

NOTICE:

Do not apply any excessive force to the heater pipe when removing the engine coolant temperature sensor.

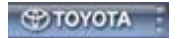
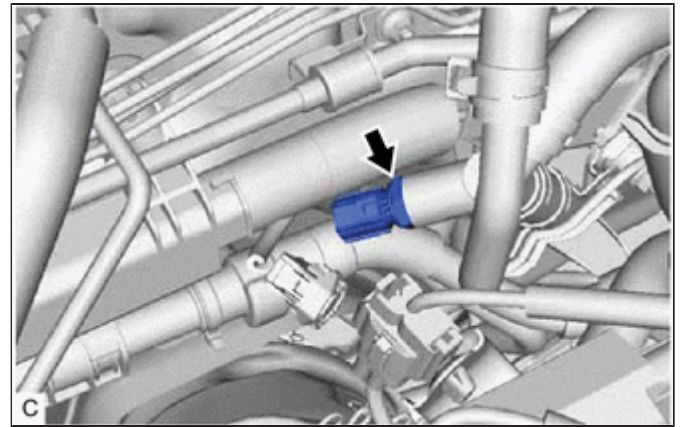

| | | |
|---|--------------|-------------------------------|
| Last Modified: 01-14-2019 | 6.8:8.0.48 | Doc ID: RM100000000TC4N |
| Model Year Start: 2016 | Model: Prius | Prod Date Range: [11/2015 -] |
| Title: 2ZR-FXE (COOLING): THERMOSTAT: COMPONENTS; 2016 - 2019 MY Prius [11/2015 -] | | |

COMPONENTS

ILLUSTRATION

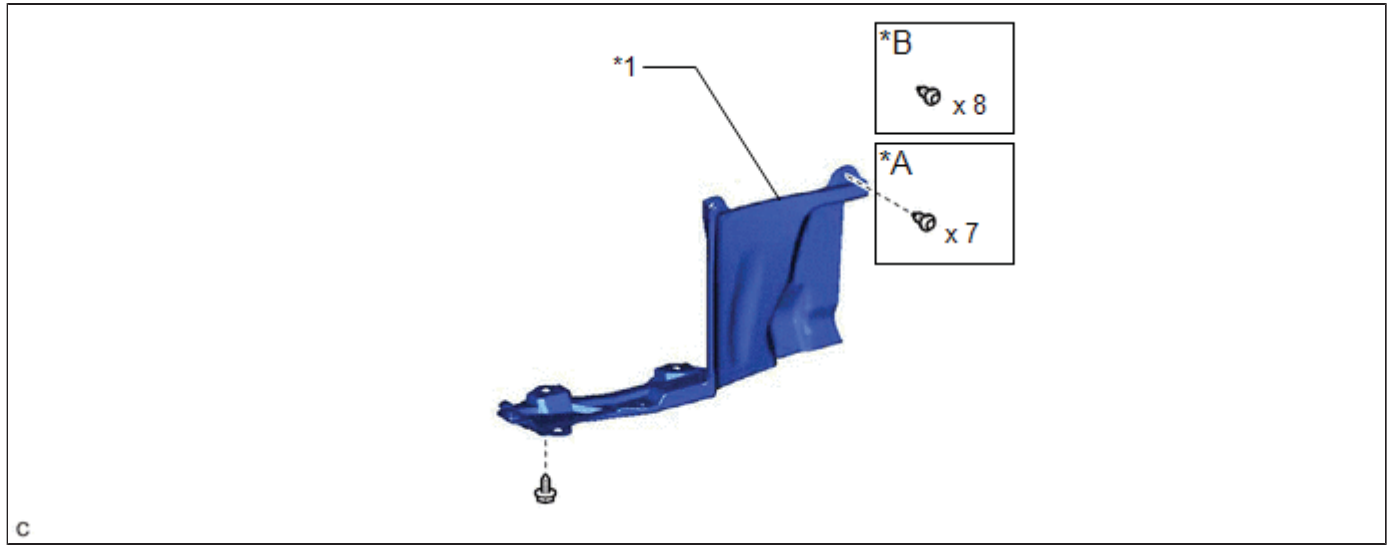

| | | | |
|----|---|----|--|
| *A | except Rough Road Area Specification Vehicles | *B | for Rough Road Area Specification Vehicles |
| *1 | REAR MOTOR UNDER COVER LH | - | - |

ILLUSTRATION

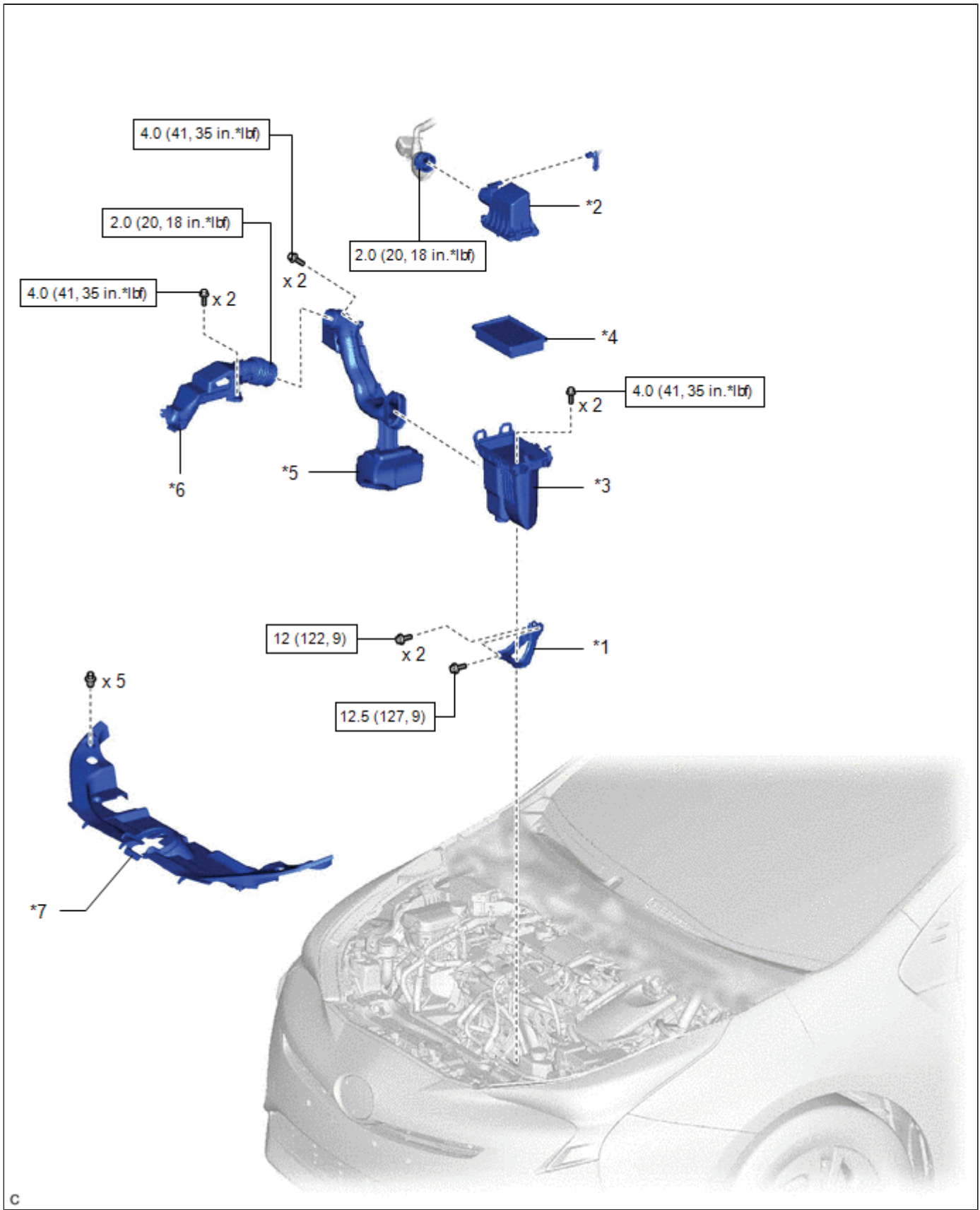

c

| | | | |
|----|-------------------------------|----|---|
| *1 | AIR CLEANER BRACKET | *2 | AIR CLEANER CAP SUB-ASSEMBLY |
| *3 | AIR CLEANER CASE SUB-ASSEMBLY | *4 | AIR CLEANER FILTER ELEMENT SUB-ASSEMBLY |

| | | | |
|---|---|----|-------------------------|
| *5 | INLET NO. 1 AIR CLEANER | *6 | INLET NO. 2 AIR CLEANER |
| *7 | RADIATOR SUPPORT OPENING COVER | - | - |
|  | N*m (kgf*cm, ft.*lbf): Specified torque | - | - |

ILLUSTRATION

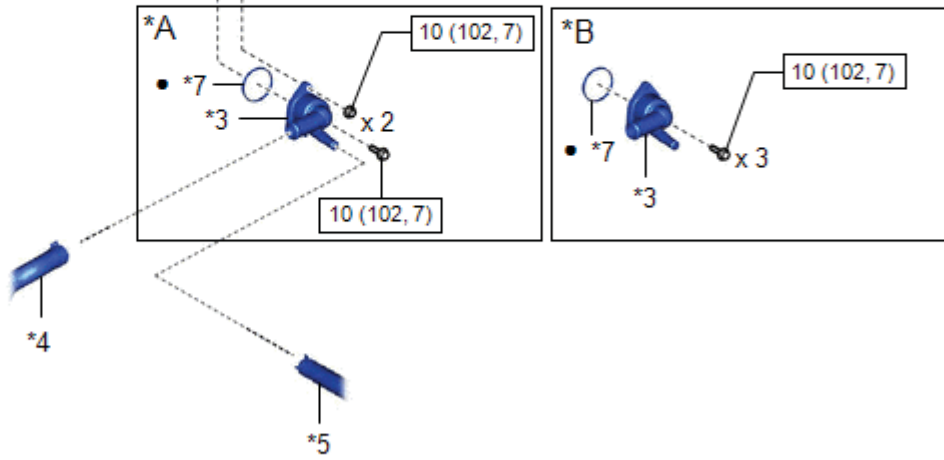
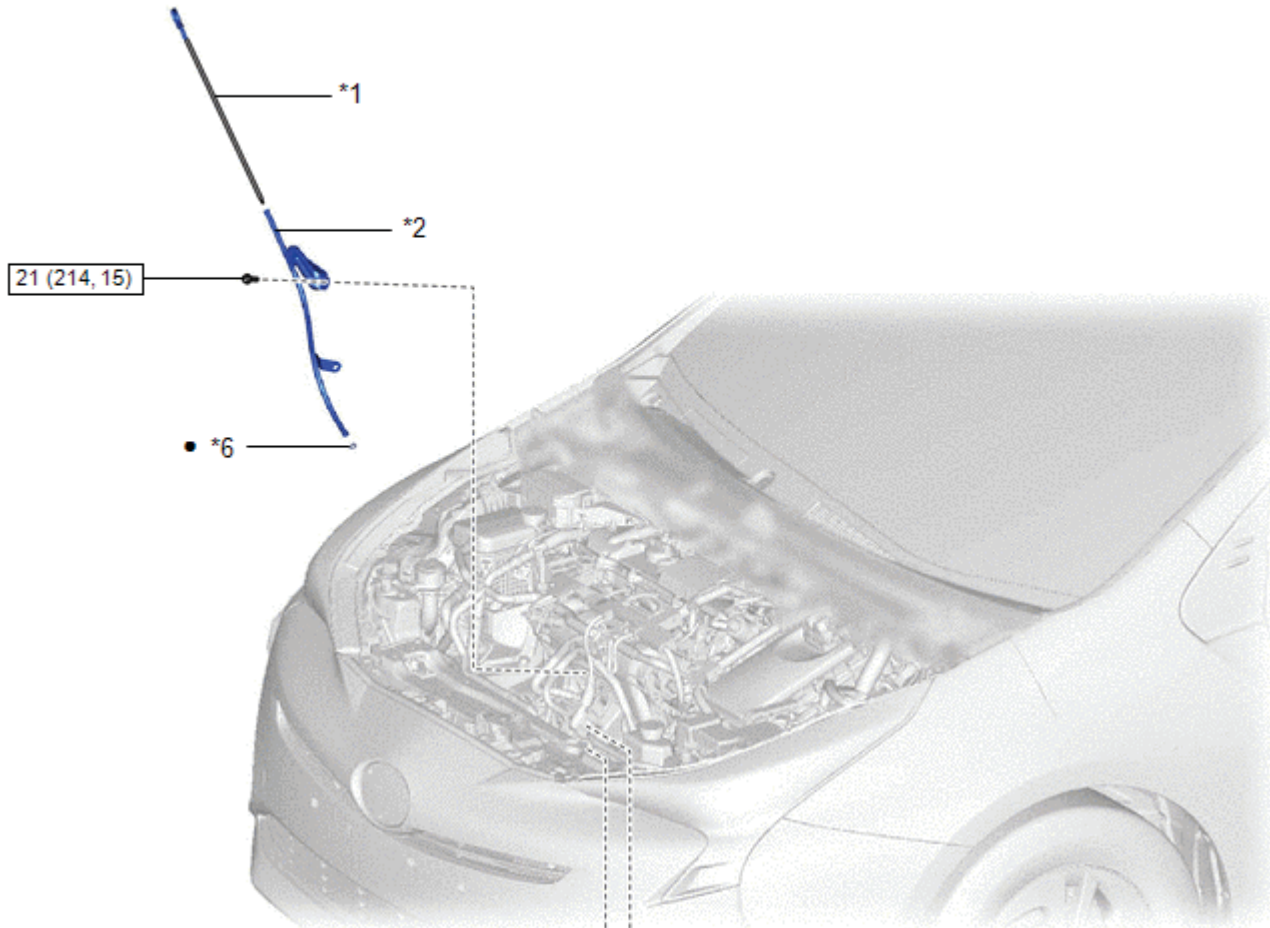

c

| *A | Type A | *B | Type B |
|----|-----------------------------|----|---------------------------------|
| *1 | ENGINE OIL LEVEL DIPSTICK | *2 | ENGINE OIL LEVEL DIPSTICK GUIDE |
| *3 | WATER INLET WITH THERMOSTAT | *4 | NO. 2 RADIATOR HOSE |

| | | | |
|---|--|----|---|
| | SUB-ASSEMBLY | | |
| *5 | NO. 3 WATER BY-PASS HOSE | *6 | ENGINE OIL LEVEL DIPSTICK GUIDE O-RING |
| *7 | GASKET | - | - |
|  | N*m (kgf*cm, ft.*lbf): Specified torque | • | Non-reusable part |

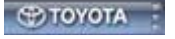

| | | |
|---|--------------|-------------------------------|
| Last Modified: 01-14-2019 | 6.8:8.0.48 | Doc ID: RM100000000TC4M |
| Model Year Start: 2016 | Model: Prius | Prod Date Range: [11/2015 -] |
| Title: 2ZR-FXE (COOLING): THERMOSTAT: INSPECTION; 2016 - 2019 MY Prius [11/2015 -] | | |

INSPECTION

PROCEDURE

1. INSPECT WATER INLET WITH THERMOSTAT SUB-ASSEMBLY

- Immerse the water inlet with thermostat sub-assembly in water and then gradually heat the water.
- Check that the valve of the water inlet with thermostat sub-assembly opens at the specified temperature.

Standard Valve Opening Temperature:

| SPECIFIED CONDITION |
|---------------------|
| 80 to 84 °C |
| 176 to 183 °F |

If the result is not as specified, replace the water inlet with thermostat sub-assembly.

- Check the valve lift.

Standard Valve Lift:

| COMPRESSION SPRING SHAPE | CONDITION | SPECIFIED CONDITION |
|--------------------------|-----------------|---------------------|
| Tapered | 95°C (203°F) | 10 to 14 mm |
| Tapered | 95°C (203°F) | 0.394 to 0.551 in. |
| Straight | 95°C (203°F) | 8 mm or higher |
| Straight | 95°C (203°F) | 0.315 in. or higher |

If the result is not as specified, replace the water inlet with thermostat sub-assembly.

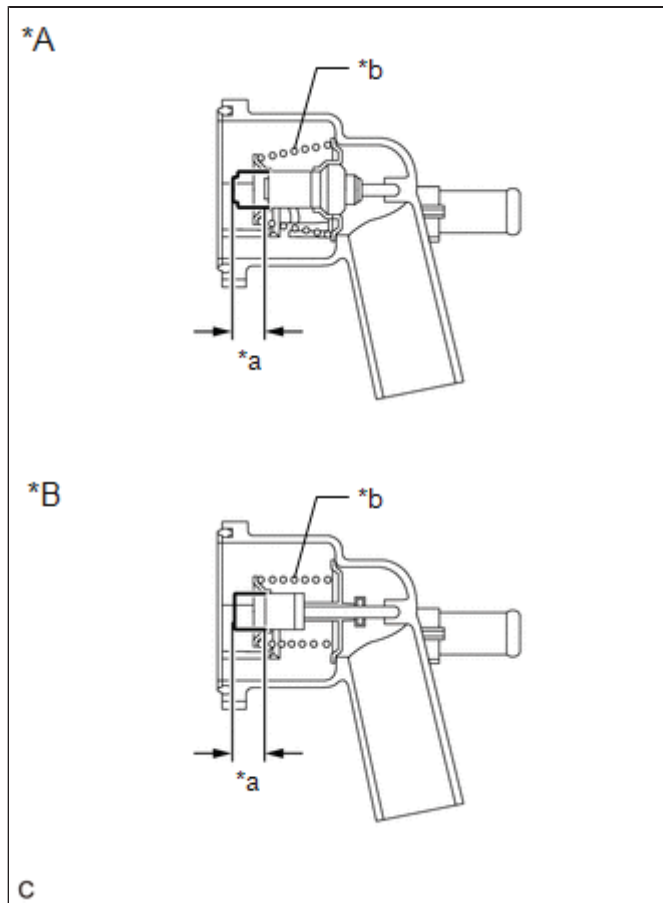

| | |
|----|------------------------------------|
| *A | Compression Spring Shape: Tapered |
| *B | Compression Spring Shape: Straight |
| *a | Valve Lift |

(d) Check that the valve is fully closed when the water inlet with thermostat sub-assembly is at low temperatures (below 77°C (171°F)).

If it is not fully closed, replace the water inlet with thermostat sub-assembly.



| | | |
|--|---------------------|--------------------------------------|
| Last Modified: 01-14-2019 | 6.8:8.0.48 | Doc ID: RM100000000TC4L |
| Model Year Start: 2016 | Model: Prius | Prod Date Range: [11/2015 -] |
| Title: 2ZR-FXE (COOLING): THERMOSTAT: INSTALLATION; 2016 - 2019 MY Prius [11/2015 -] | | |

[INSTALLATION](#)

[PROCEDURE](#)

1. INSTALL WATER INLET WITH THERMOSTAT SUB-ASSEMBLY

(a) Type A:

- (1) Install a new gasket to the water inlet with thermostat sub-assembly.
- (2) Install the water inlet with thermostat sub-assembly with the 2 nuts and bolt.

Torque:

10 N·m { 102 kgf·cm, 7 ft·lbf }

(b) Type B:

- (1) Install a new gasket to the water inlet with thermostat sub-assembly.
- (2) Install the water inlet with thermostat sub-assembly with the 3 bolts.

Torque:

10 N·m { 102 kgf·cm, 7 ft·lbf }

- (c) Connect the No. 2 radiator hose and No. 3 water by-pass hose to the water inlet with thermostat sub-assembly and slide the 2 clips to secure them.

2. INSTALL ENGINE OIL LEVEL DIPSTICK GUIDE

- (a) Install a new engine oil level dipstick guide O-ring to the engine oil level dipstick guide.
- (b) Apply a light coat of engine oil to the engine oil level dipstick guide O-ring.
- (c) Insert the engine oil level dipstick guide end into the oil pan sub-assembly.
- (d) Install the engine oil level dipstick guide to the cylinder block sub-assembly with the bolt.

Torque:

21 N·m { 214 kgf·cm, 15 ft·lbf }

- (e) Engage the clamp to connect the engine wire to the engine oil level dipstick guide.

3. INSTALL ENGINE OIL LEVEL DIPSTICK

- (a) Install the engine oil level dipstick to the engine oil level dipstick guide.

4. INSTALL INLET NO. 1 AIR CLEANER

Click here [INFO](#)

5. INSTALL AIR CLEANER BRACKET

Click here [INFO](#)

6. INSTALL AIR CLEANER CASE SUB-ASSEMBLY

Click here [INFO](#)

7. INSTALL AIR CLEANER FILTER ELEMENT SUB-ASSEMBLY

Click here [INFO](#)

8. INSTALL AIR CLEANER CAP SUB-ASSEMBLY

Click here [INFO](#)

9. INSTALL INLET NO. 2 AIR CLEANER

Click here [INFO](#)

10. INSTALL RADIATOR SUPPORT OPENING COVER

Click here [INFO](#) [INFO](#)

11. ADD ENGINE COOLANT (for Engine)

Click here [INFO](#) [INFO](#)

12. INSPECT FOR COOLANT LEAK (for Engine)

Click here [INFO](#) [INFO](#)

13. INSTALL REAR MOTOR UNDER COVER LH

Click here [INFO](#)

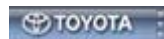

| | | |
|---|---------------------|--------------------------------------|
| Last Modified: 01-14-2019 | 6.8:8.0.48 | Doc ID: RM100000000TC40 |
| Model Year Start: 2016 | Model: Prius | Prod Date Range: [11/2015 -] |
| Title: 2ZR-FXE (COOLING): THERMOSTAT: REMOVAL; 2016 - 2019 MY Prius [11/2015 -] | | |

REMOVAL

PROCEDURE

1. REMOVE REAR MOTOR UNDER COVER LH

Click here [INFO](#)

2. DRAIN ENGINE COOLANT (for Engine)

Click here [INFO](#) [INFO](#)

3. REMOVE RADIATOR SUPPORT OPENING COVER

Click here [INFO](#) [INFO](#)

4. REMOVE INLET NO. 2 AIR CLEANER

Click here [INFO](#)

5. REMOVE AIR CLEANER CAP SUB-ASSEMBLY

Click here [INFO](#)

6. REMOVE AIR CLEANER FILTER ELEMENT SUB-ASSEMBLY

Click here [INFO](#)

7. REMOVE AIR CLEANER CASE SUB-ASSEMBLY

Click here [INFO](#)

8. REMOVE AIR CLEANER BRACKET

Click here [INFO](#)

9. REMOVE INLET NO. 1 AIR CLEANER

Click here [INFO](#)

10. REMOVE ENGINE OIL LEVEL DIPSTICK

(a) Remove the engine oil level dipstick from the engine oil level dipstick guide.

11. REMOVE ENGINE OIL LEVEL DIPSTICK GUIDE

(a) Disengage the clamp to disconnect the engine wire from the engine oil level dipstick guide.

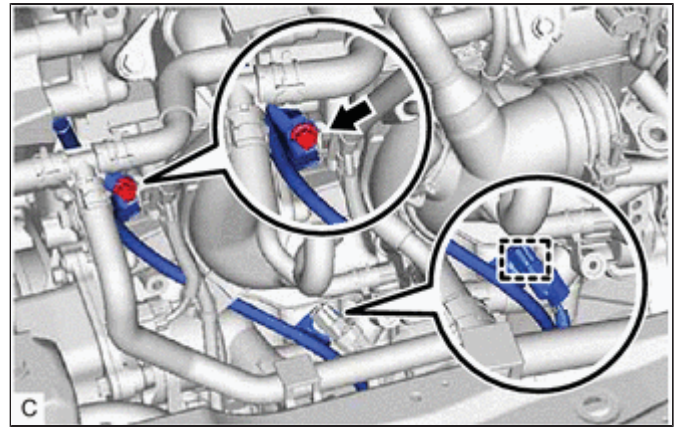

(b) Remove the bolt and engine oil level dipstick guide from the cylinder block sub-assembly and oil pan sub-assembly.

(c) Remove the engine oil level dipstick guide O-ring from the engine oil level dipstick guide.

12. REMOVE WATER INLET WITH THERMOSTAT SUB-ASSEMBLY

(a) Slide the 2 clips and disconnect the No. 2 radiator hose and No. 3 water by-pass hose from the water inlet with thermostat sub-assembly.

NOTICE:

- Do not apply force to the water inlet with thermostat sub-assembly when disconnecting the No. 3 water by-pass hose.
- Do not damage the water inlet with thermostat sub-assembly.

HINT:

When disconnecting the No. 3 water by-pass hose, slide the clip, rotate the hose and pull it straight off the pipe.

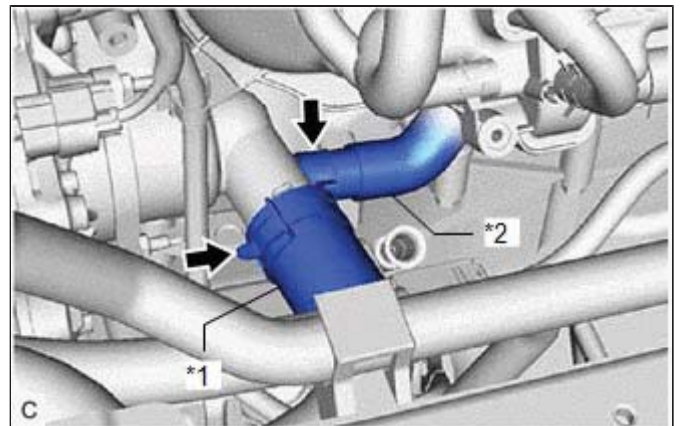

| | |
|----|--------------------------|
| *1 | No. 2 Radiator Hose |
| *2 | No. 3 Water By-pass Hose |

(b) Type A:

(1) Remove the 2 nuts, bolt and water inlet with thermostat sub-assembly.

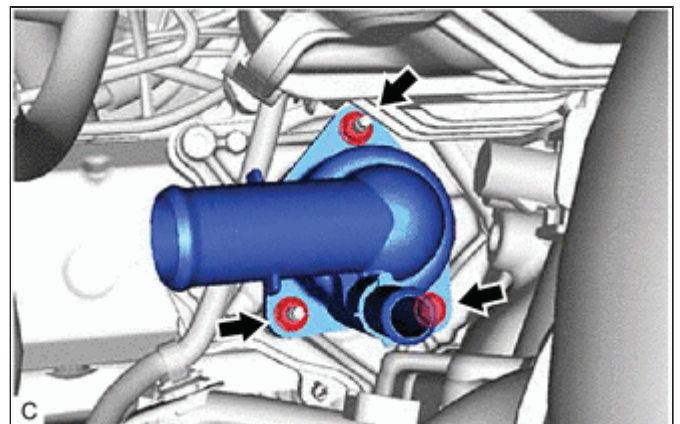

(2) Remove the gasket from the water inlet with thermostat sub-assembly.

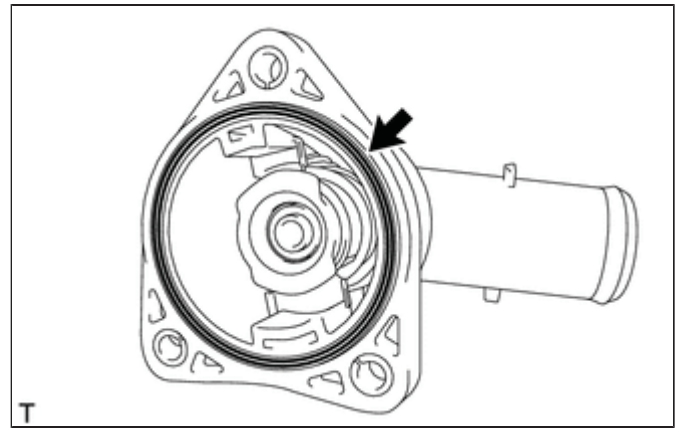

(c) Type B:

(1) Remove the 3 bolts and water inlet with thermostat sub-assembly.

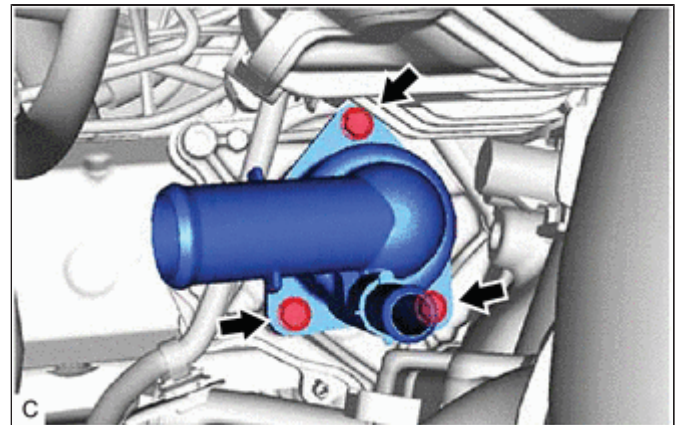

(2) Remove the gasket from the water inlet with thermostat sub-assembly.

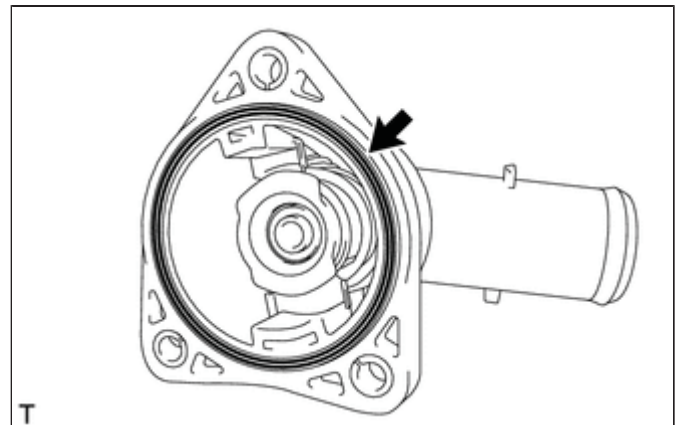

| | | |
|---|--------------|-------------------------------|
| Last Modified: 01-14-2019 | 6.8:8.0.48 | Doc ID: RM100000000TC4J |
| Model Year Start: 2016 | Model: Prius | Prod Date Range: [11/2015 -] |
| Title: 2ZR-FXE (COOLING): WATER PUMP: COMPONENTS; 2016 - 2019 MY Prius [11/2015 -] | | |

COMPONENTS

ILLUSTRATION

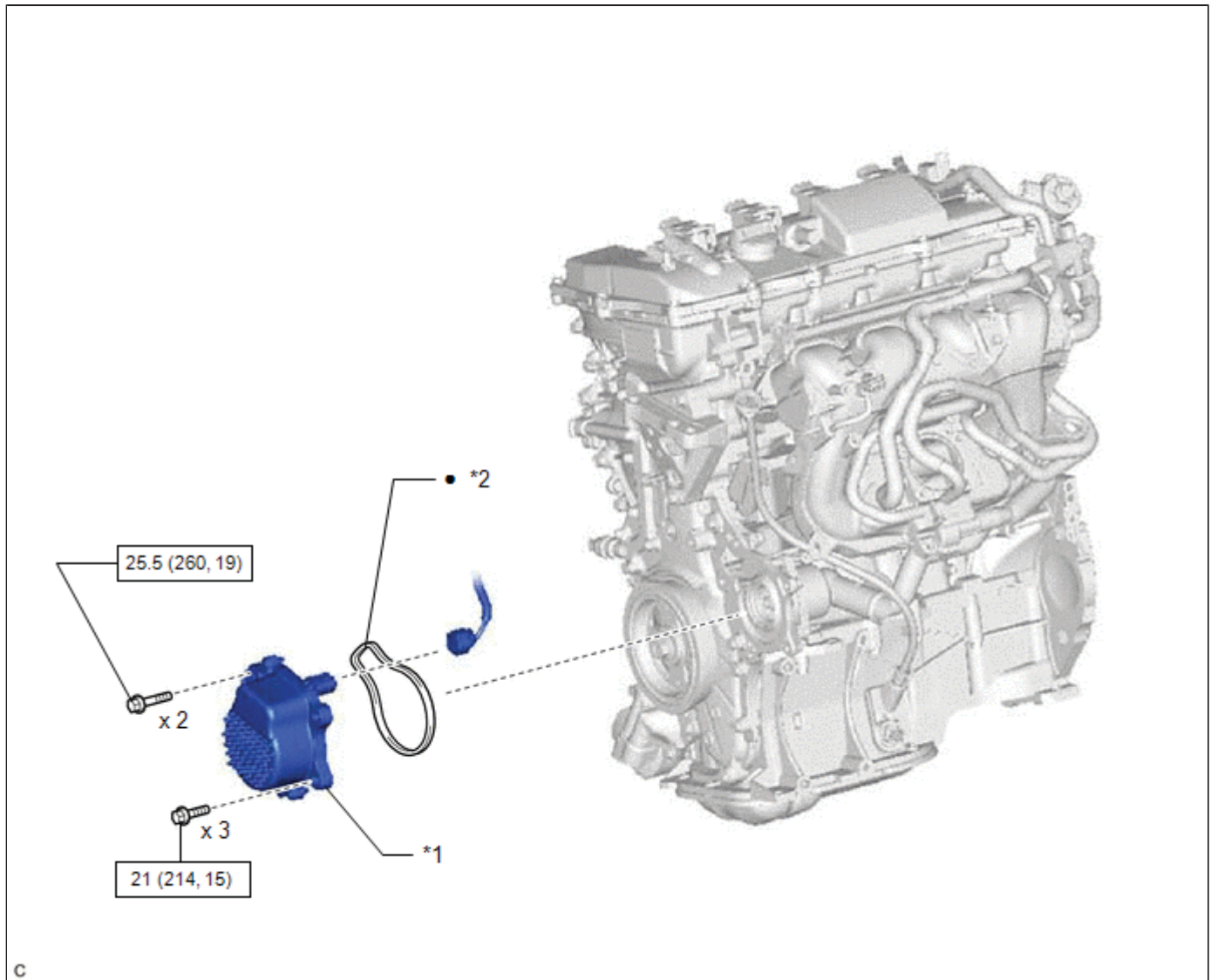

| | | | |
|----|---|----|-------------------|
| *1 | ENGINE WATER PUMP ASSEMBLY | *2 | GASKET |
| | N*m (kgf*cm, ft.*lbf): Specified torque | • | Non-reusable part |

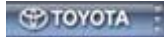

| | | |
|--|---------------------|--------------------------------------|
| Last Modified: 01-14-2019 | 6.8:8.0.48 | Doc ID: RM100000000TC4I |
| Model Year Start: 2016 | Model: Prius | Prod Date Range: [11/2015 -] |
| Title: 2ZR-FXE (COOLING): WATER PUMP: INSTALLATION; 2016 - 2019 MY Prius [11/2015 -] | | |

INSTALLATION

PROCEDURE

1. INSTALL ENGINE WATER PUMP ASSEMBLY

(a) Install a new gasket to the engine water pump assembly.

HINT:

Be sure to clean the contact surfaces.

(b) Install the engine water pump assembly to the timing chain cover sub-assembly with the 5 bolts.

Torque:

Bolt (A) :

25.5 N·m { 260 kgf·cm, 19 ft·lbf }

Bolt (B) :

21 N·m { 214 kgf·cm, 15 ft·lbf }

Bolt Length:

| ITEM | LENGTH |
|----------|------------------|
| Bolt (A) | 55 mm (2.17 in.) |
| Bolt (B) | 30 mm (1.18 in.) |

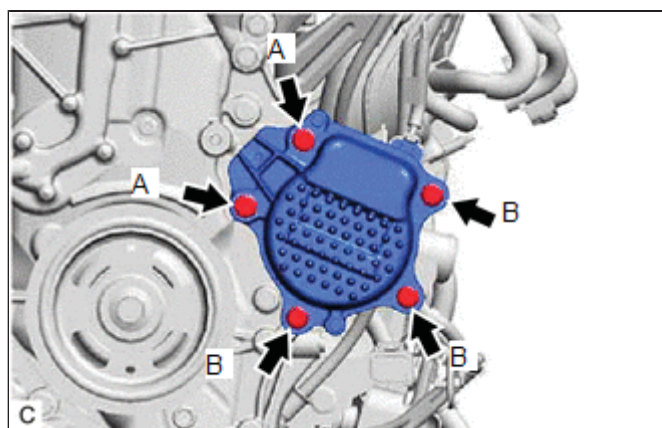

(c) Connect the engine water pump assembly connector.

2. INSTALL ENGINE ASSEMBLY WITH TRANSAXLE

Click here [INFO](#) [INFO](#) [INFO](#)

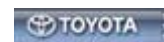

| | | |
|---|---------------------|--------------------------------------|
| Last Modified: 01-14-2019 | 6.8:8.0.48 | Doc ID: RM100000000TC4K |
| Model Year Start: 2016 | Model: Prius | Prod Date Range: [11/2015 -] |
| Title: 2ZR-FXE (COOLING): WATER PUMP: REMOVAL; 2016 - 2019 MY Prius [11/2015 -] | | |

REMOVAL

CAUTION / NOTICE / HINT

The necessary procedures (adjustment, calibration, initialization, or registration) that must be performed after parts are removed and installed, or replaced during engine water pump assembly removal/installation are shown below.

Necessary Procedure After Parts Removed/Installed/Replaced

| REPLACED PART OR PERFORMED PROCEDURE | NECESSARY PROCEDURE | EFFECT/INOPERATIVE FUNCTION WHEN NECESSARY PROCEDURE NOT PERFORMED | LINK |
|---|---|--|---|
| Auxiliary battery terminal is disconnected/reconnected | Memorize steering angle neutral point | Lane departure alert system (w/ Steering Control) | INFO |
| | | Intelligent clearance sonar system*1 | |
| Simple advanced parking guidance system*1 | | | |
| Pre-collision system | | | |
| | Initialize back door lock | Power door lock control system | INFO |
| Replacement of inverter with converter assembly | Resolver learning | <ul style="list-style-type: none"> • DTCs are stored • Slight vibration at a vehicle speed of 5 km/h (3 mph) or less • Shock or vibration during acceleration | INFO for Nickel Metal Hydride Battery INFO for Lithium-ion Battery |
| Replacement of ECM | Perform Vehicle Identification Number (VIN) registration | MIL comes on | INFO |
| <ul style="list-style-type: none"> • Replacement of throttle body assembly • Replacement of engine assembly • Gas leak from exhaust system is repaired | Inspection After Repair | <ul style="list-style-type: none"> • Poor idle, etc. • Engine start function, etc. | INFO |
| Suspension, tires, etc. (The vehicle height changes because of suspension or tire replacement) | <ul style="list-style-type: none"> • Ultrasonic sensor detection angle • Ultrasonic sensor detection angle registration | <ul style="list-style-type: none"> • Intelligent clearance sonar system • Simple advanced parking guidance system | INFO INFO |

| | | | |
|--|--|--|--|
| Front wheel alignment adjustment | <ol style="list-style-type: none"> 1. Clear zero point calibration data. 2. Perform yaw rate and acceleration sensor zero point calibration. | <p>DTCs are stored</p> <ul style="list-style-type: none"> • ABS warning light illuminates • Brake warning light/yellow (minor malfunction) illuminates • Slip indicator light illuminates • VSC disabled or malfunctions | <p>INFO INFO</p> |
| Replacement of hybrid vehicle transaxle assembly | <ul style="list-style-type: none"> • Resolver learning • Initialize resolver | <ul style="list-style-type: none"> • DTCs are stored • Slight vibration at a vehicle speed of 5 km/h (3 mph) or less • Shock or vibration during acceleration | <p>INFO for Nickel Metal Hydride Battery</p> <p>INFO for Lithium-ion Battery</p> |

*1: When performing learning using the Techstream.

Click here [INFO](#) [INFO](#)

PROCEDURE

1. REMOVE ENGINE ASSEMBLY WITH TRANSAXLE

Click here [INFO](#) [INFO](#) [INFO](#)

2. REMOVE ENGINE WATER PUMP ASSEMBLY

(a) Disconnect the engine water pump assembly connector..

(b) Remove the 5 bolts and engine water pump assembly from the timing chain cover sub-assembly.

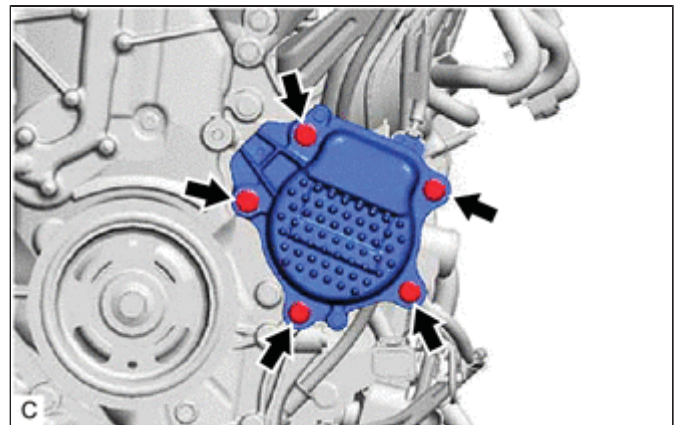

(c) Remove the gasket from the engine water pump assembly.

