

COMPONENTS

ILLUSTRATION

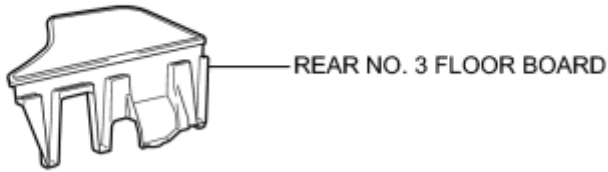

for Integrated Type:

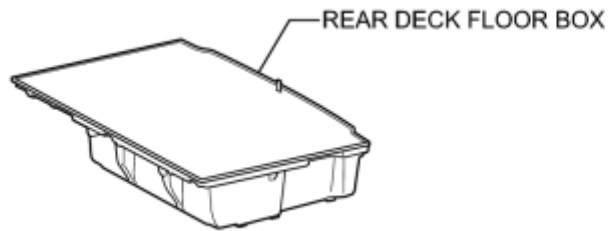

for Separate Type:

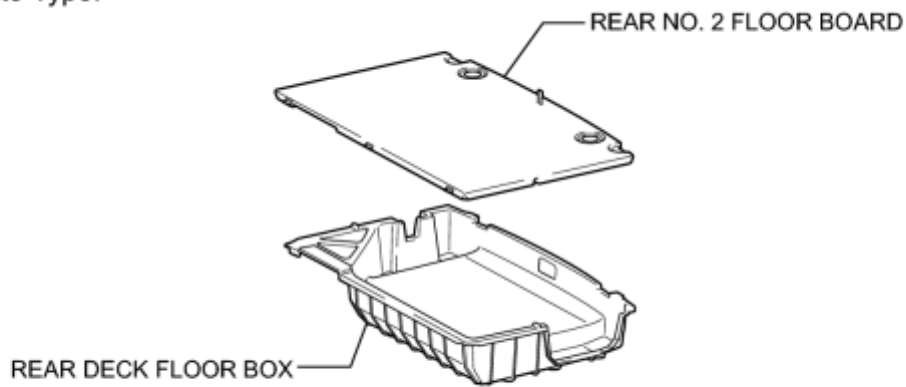

P

ILLUSTRATION

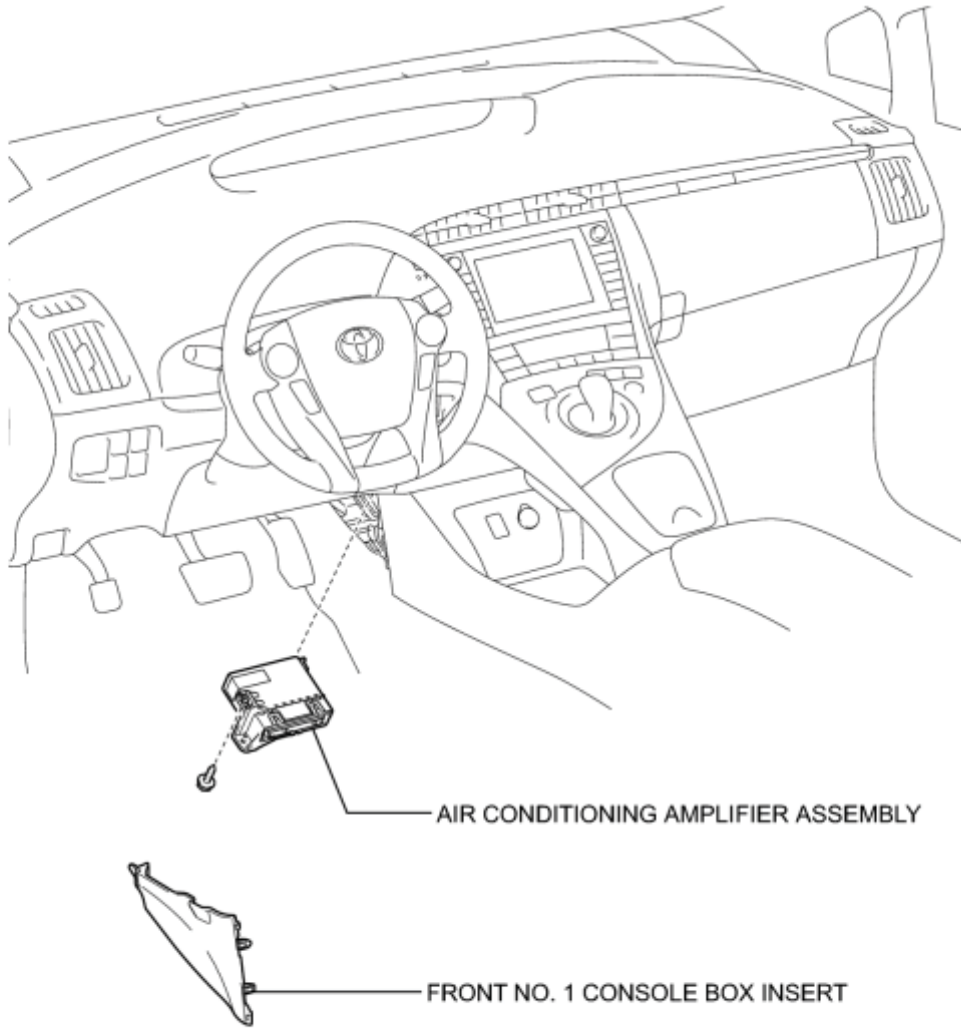

P

REMOVAL

1. REMOVE REAR NO. 2 FLOOR BOARD (for Separate Type) INFO

2. REMOVE REAR DECK FLOOR BOX INFO

3. REMOVE REAR NO. 3 FLOOR BOARD INFO

4. DISCONNECT CABLE FROM NEGATIVE BATTERY TERMINAL

NOTICE:

When disconnecting the cable, some systems need to be initialized after the cable is reconnected INFO.

5. REMOVE FRONT NO. 1 CONSOLE BOX INSERT INFO

6. REMOVE AIR CONDITIONING AMPLIFIER ASSEMBLY

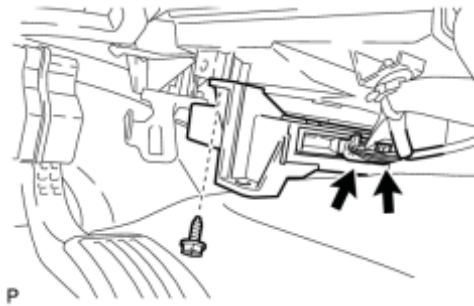

(a) Disconnect each connector and remove the screw.



(b) Disengage the guide as shown in the illustration.

(c) Disengage the guide and remove the air conditioning amplifier assembly as shown in the illustration.

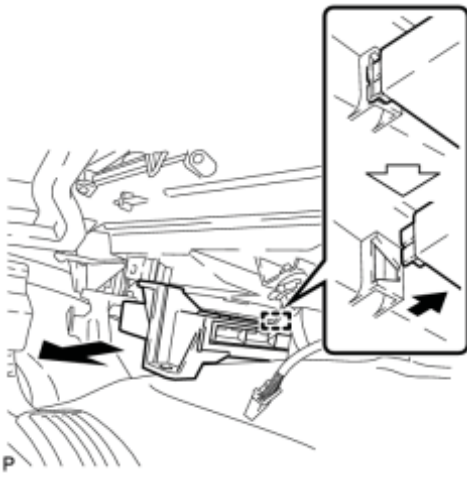

INSTALLATION

1. INSTALL AIR CONDITIONING AMPLIFIER ASSEMBLY

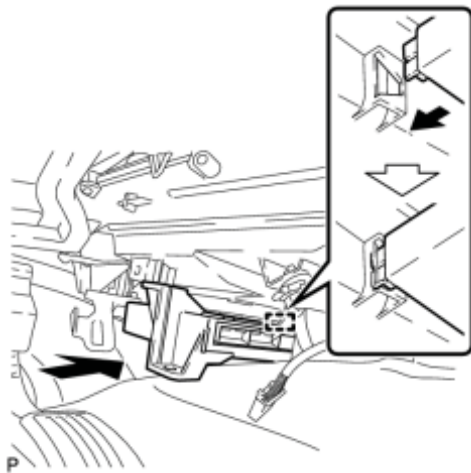

(a) Engage the guide as shown in the illustration.

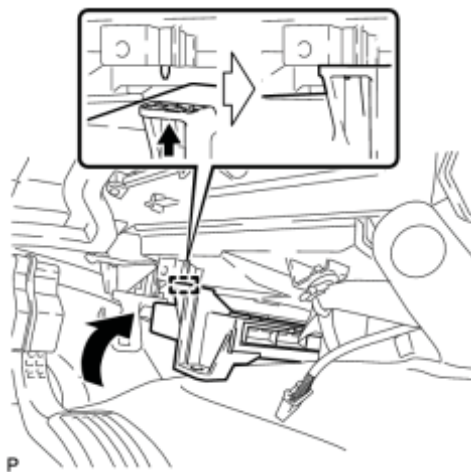

(b) Engage the guide and install the air conditioning amplifier assembly as shown in the illustration.

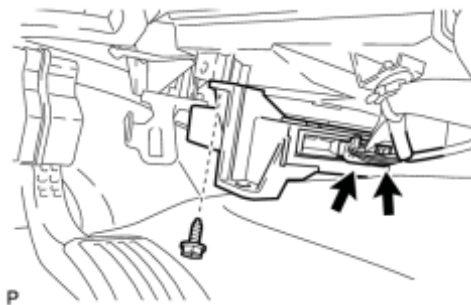

(c) Install the screw and connect each connector.

2. INSTALL FRONT NO. 1 CONSOLE BOX INSERT INFO

3. CONNECT CABLE TO NEGATIVE BATTERY TERMINAL

NOTICE:
2010 Toyota Prius

When disconnecting the cable, some systems need to be initialized after the cable is reconnected INFO.

4. INSTALL REAR NO. 3 FLOOR BOARD_ INFO

5. INSTALL REAR DECK FLOOR BOX_ INFO

6. INSTALL REAR NO. 2 FLOOR BOARD (for Separate Type)_ INFO

COMPONENTS

ILLUSTRATION

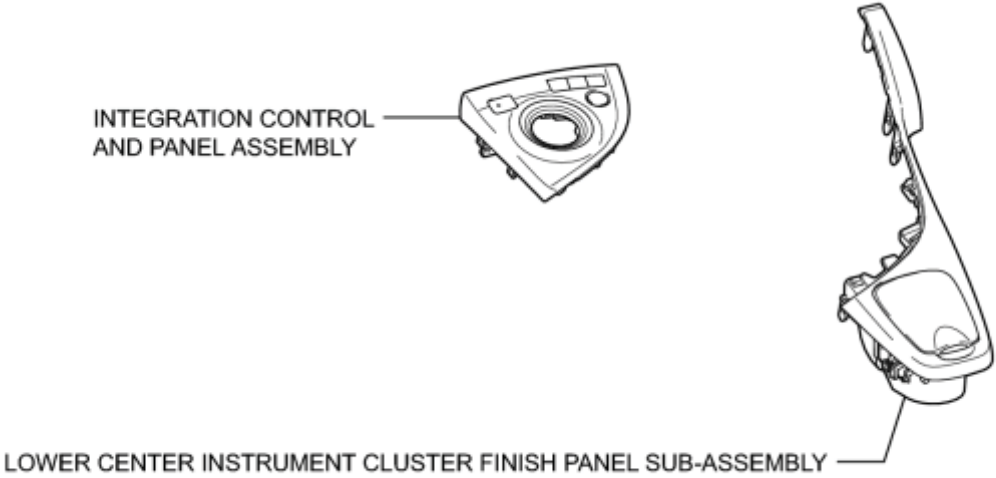
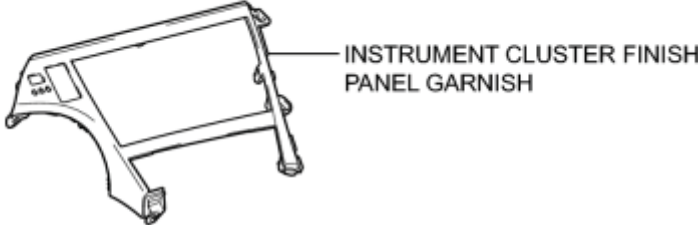

P

REMOVAL

1. REMOVE INTEGRATION CONTROL AND PANEL ASSEMBLY_ INFO

2. REMOVE LOWER CENTER INSTRUMENT CLUSTER FINISH PANEL SUB-ASSEMBLY_ INFO

3. REMOVE INSTRUMENT CLUSTER FINISH PANEL GARNISH_ INFO

4. REMOVE AIR CONDITIONING CONTROL ASSEMBLY

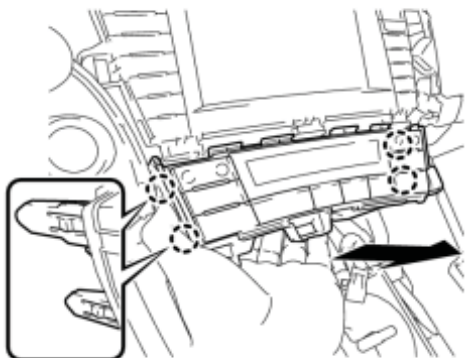

(a) Disengage the 4 claws and remove the air conditioning control assembly as shown in the illustration.

P

(b) Disconnect the connector.

NOTICE:

Since the connectors for the air conditioning control assembly and the integration control and panel sub-assembly are the same shape, mark them so that they will not be reconnected incorrectly.



INSTALLATION

1. INSTALL AIR CONDITIONING CONTROL ASSEMBLY

(a) Connect the connector.

NOTICE:

Since the connectors for the air conditioning control assembly and the integration control and panel sub-assembly are the same shape, take care to connect each connector to the correct component.

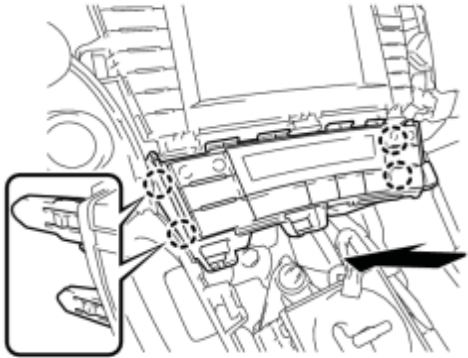

(b) Engage the 4 claws to install the air conditioning control assembly.

P

2. INSTALL INSTRUMENT CLUSTER FINISH PANEL GARNISH_ [INFO](#)

3. INSTALL LOWER CENTER INSTRUMENT CLUSTER FINISH PANEL SUB-ASSEMBLY_ [INFO](#)

4. INSTALL INTEGRATION CONTROL AND PANEL ASSEMBLY_ [INFO](#)

COMPONENTS

ILLUSTRATION

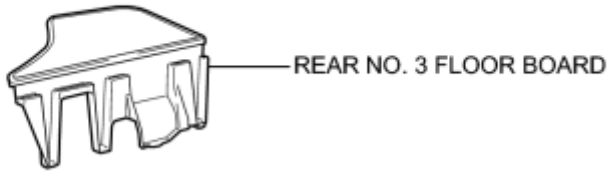

for Integrated Type:

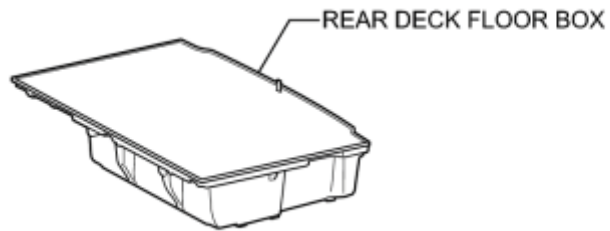

for Separate Type:

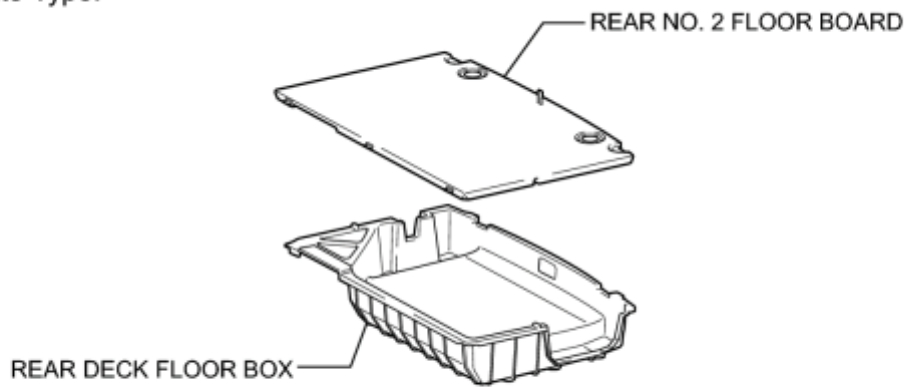

P

ILLUSTRATION

● AIR CONDITIONING PRESSURE SENSOR

11 (110, 8)

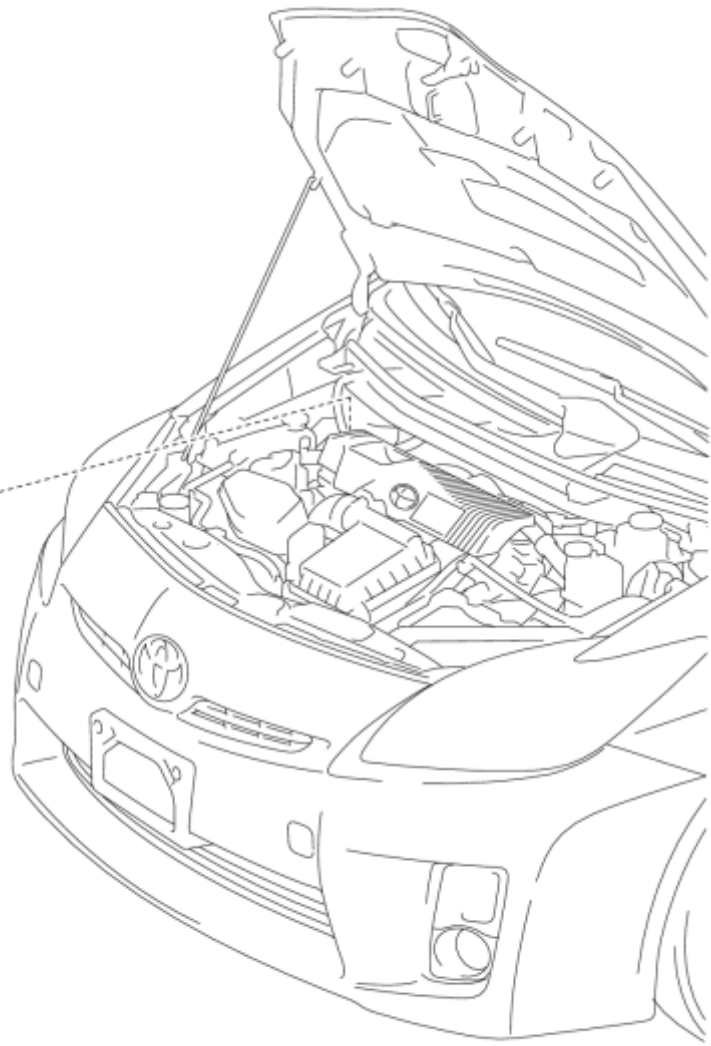

N*m (kgf*cm, ft.*lbf): Specified torque

● Non-reusable part

← Compressor oil ND-OIL 11 or equivalent

P

REMOVAL

1. RECOVER REFRIGERANT FROM REFRIGERATION SYSTEM_ INFO
2. REMOVE REAR NO. 2 FLOOR BOARD (for Separate Type)_ INFO
3. REMOVE REAR DECK FLOOR BOX_ INFO
4. REMOVE REAR NO. 3 FLOOR BOARD_ INFO
5. DISCONNECT CABLE FROM NEGATIVE BATTERY TERMINAL

NOTICE:

When disconnecting the cable, some systems need to be initialized after the cable is reconnected INFO.

6. REMOVE AIR CONDITIONING PRESSURE SENSOR

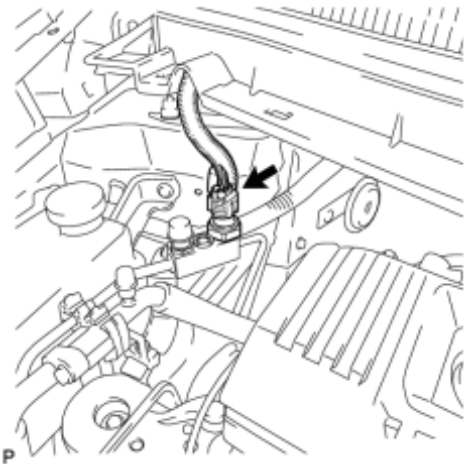

(a) Disconnect the connector.

(b) Remove the air conditioning pressure sensor.

NOTICE:

Do not deform the piping.

INSTALLATION

1. INSTALL AIR CONDITIONING PRESSURE SENSOR

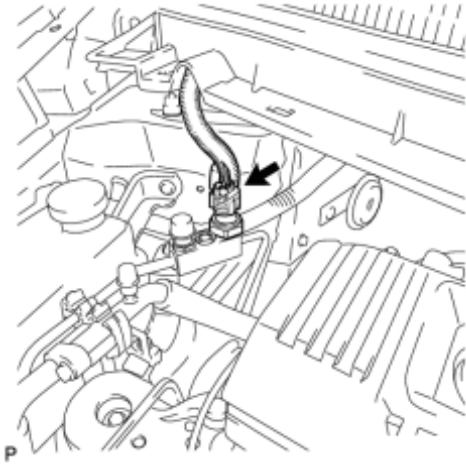

(a) Sufficiently apply compressor oil to a new air conditioning pressure sensor.

Compressor oil:

ND-OIL 11 or equivalent

- Keep the O-ring and O-ring fitting surfaces clean from dirt or any foreign objects.
- Do not use any compressor oil other than ND-OIL 11 or equivalent. If any compressor oil other than ND-OIL 11 or equivalent is used, compressor motor insulation performance may decrease, resulting in a leakage of electric power.

(b) Install the new air conditioning pressure sensor.

Torque: **11 N·m (110 kgf·cm, 8ft·lbf)**

NOTICE:

- Do not deform the piping.
- Make sure to confirm that the piping does not disengage from the plastic clamp.

(c) Connect the connector.

2. CONNECT CABLE TO NEGATIVE BATTERY TERMINAL

NOTICE:

When disconnecting the cable, some systems need to be initialized after the cable is reconnected INFO.

3. INSTALL REAR NO. 3 FLOOR BOARD INFO

4. INSTALL REAR DECK FLOOR BOX INFO

5. INSTALL REAR NO. 2 FLOOR BOARD (for Separate Type) INFO

6. CHARGE WITH REFRIGERANT INFO

7. WARM UP COMPRESSOR INFO

8. INSPECT FOR REFRIGERANT LEAK INFO

PRECAUTION

1. PRECAUTION FOR DISCONNECTING CABLE FROM NEGATIVE BATTERY TERMINAL

NOTICE:

When disconnecting the cable from the negative (-) battery terminal, initialize the following system after the terminal is reconnected.

System Name	See Procedure
Advanced Parking Guidance System	INFO

2. GENERAL PRECAUTION

(a) While using the battery during inspection, do not bring the positive (+) and negative (-) tester probes too close to each other as a short circuit may occur.

3. PRECAUTIONS WHEN USING TECHSTREAM

(a) When using the Techstream with the power switch off to troubleshoot:

Connect the Techstream to the vehicle, and turn a courtesy light switch on and off at 1.5-second intervals until communication between the Techstream and vehicle begins.

(b) After all DTCs are cleared, check if the trouble occurs again 6 seconds after the power switch is turned on (IG).

4. DO NOT HANDLE REFRIGERANT IN ENCLOSED AREA OR NEAR OPEN FLAME

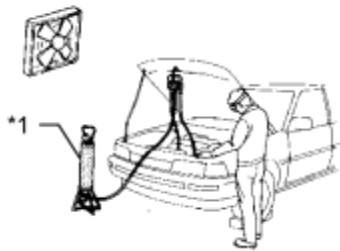

Text in Illustration

*1	Charging Cylinder
----	-------------------

5. ALWAYS WEAR EYE PROTECTION

6. BE CAREFUL NOT TO GET LIQUID REFRIGERANT IN YOUR EYES OR ON YOUR SKIN

If liquid refrigerant gets in your eyes or on your skin:

(a) Wash the area with lots of cold water.

CAUTION:

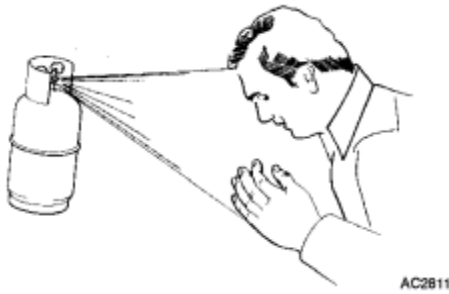

Do not rub your eyes or skin.

(b) Apply clean petroleum jelly to the skin.

(c) Go immediately to a hospital or see a physician for professional treatment.

7. NEVER HEAT CONTAINER OR EXPOSE THE CONTAINER TO AN OPEN FLAME

8. BE CAREFUL NOT TO DROP CONTAINER OR APPLY PHYSICAL SHOCKS TO IT

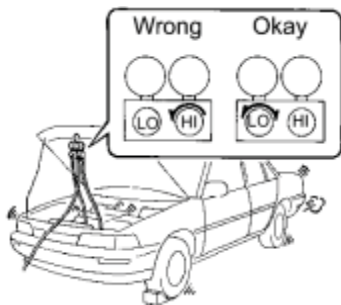

9. DO NOT OPERATE COMPRESSOR WITHOUT ENOUGH REFRIGERANT IN AIR CONDITIONING SYSTEM

If there is not enough refrigerant in the A/C system, oil lubrication will be insufficient and the compressor may be damaged.

Necessary care should be taken to avoid this.

10. DO NOT OPEN HIGH PRESSURE MANIFOLD VALVE WHILE COMPRESSOR IS OPERATING

(a) Open and close only the low pressure valve.

If the high pressure valve is opened, refrigerant flows in the reverse direction causing the charging cylinder to rupture.

11. BE CAREFUL NOT TO OVERCHARGE SYSTEM WITH REFRIGERANT

If refrigerant is overcharged, it causes problems such as insufficient cooling, poor fuel economy, engine overheating, etc.

12. DO NOT OPERATE COMPRESSOR WITHOUT REFRIGERANT

CAUTION:

Doing so may damage inside the compressor because the compressor parts always move regardless of whether the A/C system is turned on or off.

13. PRECAUTIONS TO BE OBSERVED WHILE SERVICING

CAUTION:

Always use electric insulating gloves and remove the service plug grip before beginning inspection, as inspection of the A/C system requires disconnecting high voltage connectors.

NOTICE:

- Only use ND-OIL11 for the electric inverter compressor of the air conditioning system. Using other compressor oils may be dangerous, as they may conduct electricity.
- Electrical insulation performance may decrease significantly if even a small amount of oil other than ND-OIL11 is used (or enters) in the refrigeration cycle, causing a DTC to be output.
- If other oil is accidentally used and a DTC is output, collect the compressor oil in the compressor and replace it with ND-OIL11 to increase the ND-OIL11 ratio amount.
- Replace the main components (evaporator, condenser, and compressor) if a large amount of oil other than ND-OIL11 enters the system. Failing to do so may cause electrical insulation performance to remain low, causing a DTC to be output.

14. SUPPLEMENTAL RESTRAINT SYSTEM (SRS)

(a) This vehicle is equipped with an Supplemental Restraint System (SRS) such as the driver, front passenger, side and curtain shield airbags. Failure to carry out service operations in the correct sequence could cause the SRS to unexpectedly deploy during servicing, possibly leading to a serious accident. Before servicing (including removal or installation of parts, inspection or replacement), be sure to read the precautionary notices

INFO

15. PRECAUTIONS WHEN WORKING (w/ Remote Air Conditioning System and Solar Ventilation System)

(a) Vehicles with the remote air conditioning system have the following risks that it is necessary to be aware of when performing repairs. Therefore, make sure to take care of the key (electrical transmitter) carefully so that the remote air conditioning system is not operated unexpectedly.

Risks

The electrical fan and other items in the engine compartment may operate resulting in various hazards.

The wipers may operate if the wiper switch is in the on position when the remote air conditioning system is activated. If this occurs, there is the potential for damage to the glass, wipers or injury.

When the light control switch is in the tail, head or AUTO position, the headlights may turn on.

Short circuits may occur if electrical inspections are being performed when the remote air conditioning system is turned on, because the IG circuit is powered at this time.

CAUTION:

Failure to take proper care with the key (electrical transmitter) may cause the system to be accidentally operated. This can lead to an accident and damage to parts or a serious injury.

HINT:

Make sure to store the key (electrical transmitter) in a box with the switch side facing up, and place the box where it can be monitored so that no one cannot operate the remote A/C switch.

(b) When performing repairs on vehicles with the solar ventilation system, turn the solar ventilation switch off.

CAUTION:

Depending on the environment around the vehicle, performing repairs with the solar ventilation switch on may cause the blower motor to operate unexpectedly, resulting in various hazards. This can lead to damage to parts or a serious injury.

PARTS LOCATION

ILLUSTRATION

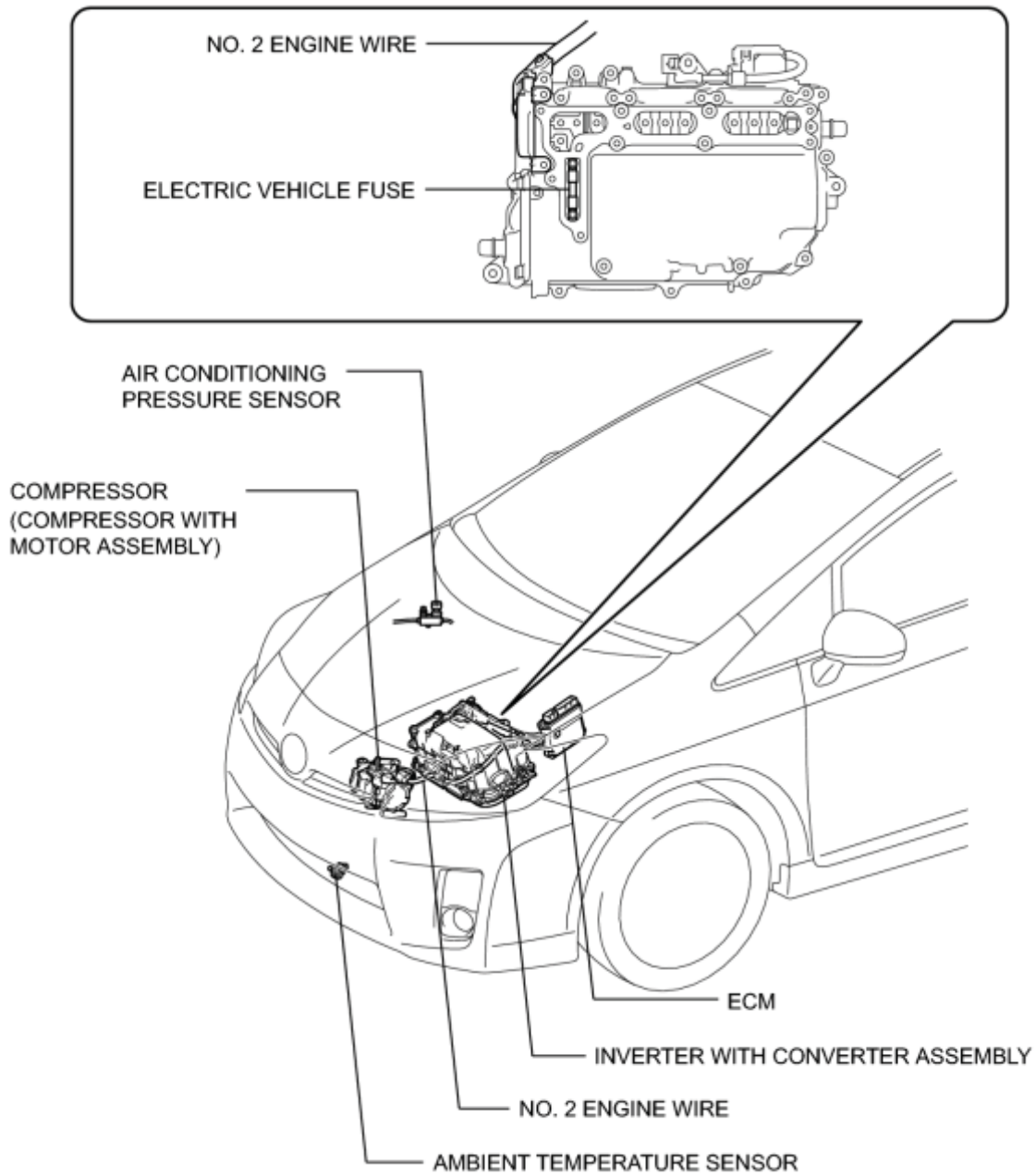

H

ILLUSTRATION

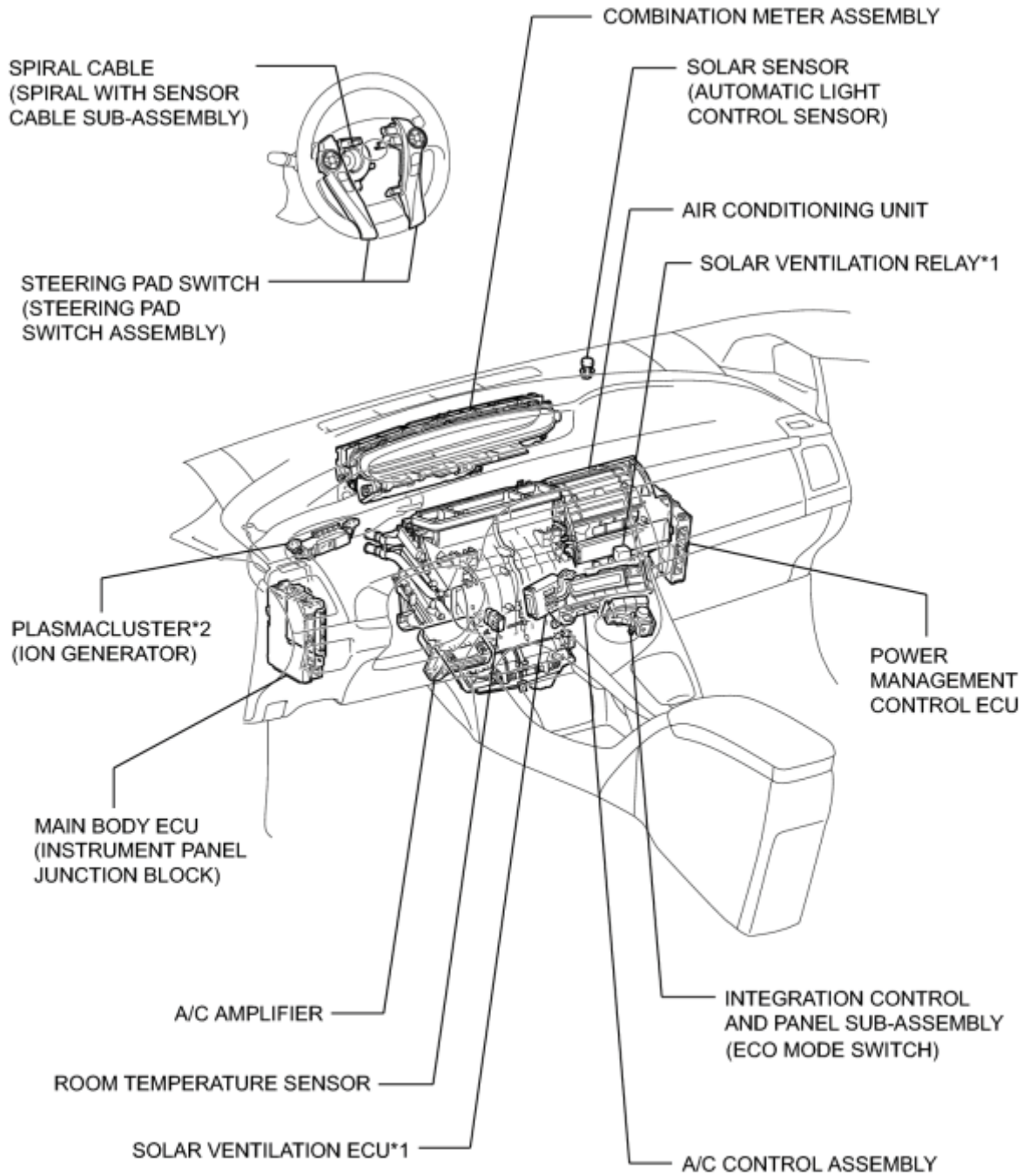

*1: w/ Solar Ventilation System

*2: w/ Plasmacluster (Ion Generator)

H

ILLUSTRATION

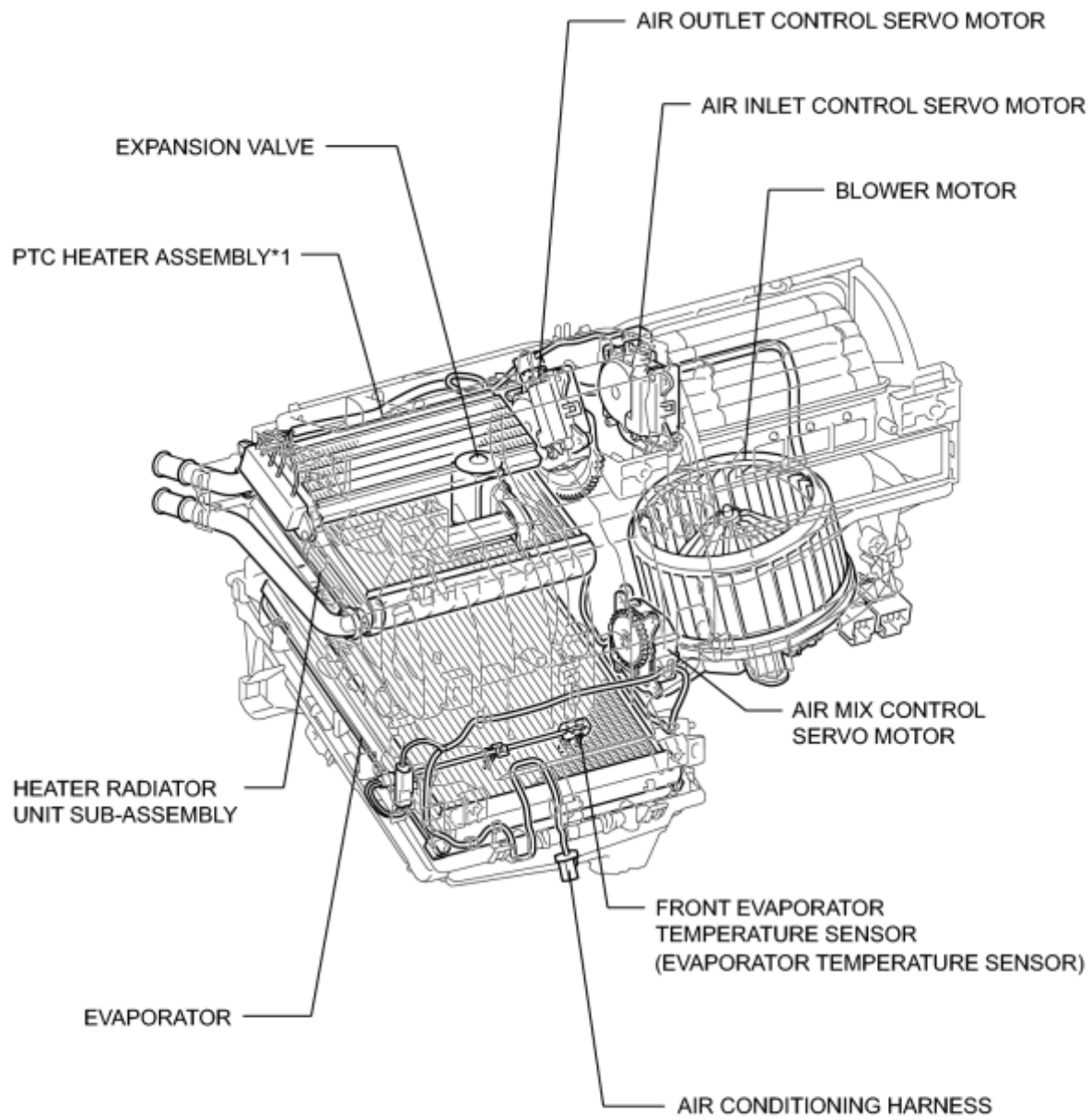

*1: w/ PTC Heater Assembly

H

SYSTEM DIAGRAM

1. Air Conditioning System

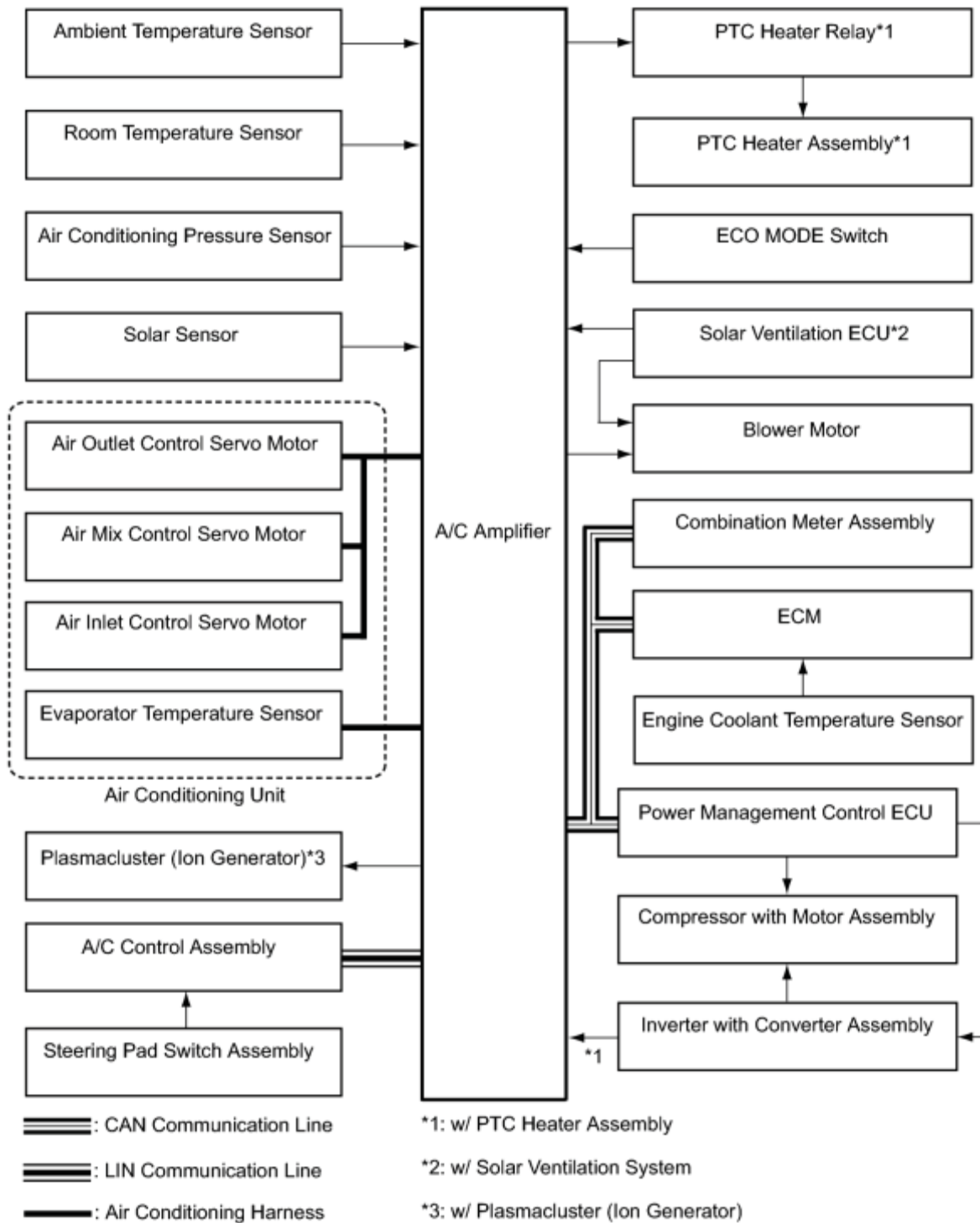

Communication Table

Sender	Receiver	Signal	Communication Line
A/C amplifier	ECM	Heater idle up request signal	CAN
		ECO switch information signal	
		Prior A/C control request signal	
		Cooling fan motor driving request signal	
		Refrigerant gas pressure sensor signal	
		Ambient temperature signal	
A/C amplifier	Power management control ECU	Heater idle up request signal	CAN
		ECO switch information signal	
		Prior A/C control request signal	
		Water pump ON/OFF request signal	
		Inverter STB ON/OFF request signal	
		Electrical compressor start signal	
		Electrical compressor target revolutions signal	
		A/C control state signal	
A/C amplifier	A/C control assembly	Ambient temperature indicator signal	LIN
		MODE indication signal	
		Blower level indication signal	
		Set temperature indication signal	
Combination meter assembly	A/C amplifier	Vehicle speed signal	CAN
ECM	A/C amplifier	Engine revolution speed signal	CAN
		Engine coolant temperature signal	
Power management control ECU	A/C amplifier	A/C inverter main power supply voltage signal	CAN
		A/C inverter output signal	
		A/C inverter internal power source malfunction	
		STB wire short	
		State of STB	
		A/C inverter temperature information	
		Compressor start flag	

Sender	Receiver	Signal	Communication Line	
		Compressor humidity control start flag		
		A/C motor revolution signal		
		A/C motor current request signal		
A/C control assembly	A/C amplifier	AUTO switch signal	LIN	
		A/C switch signal		
		Fr DEF switch signal		
		Rr DEF switch signal		
		MODE switch signal		
		REC/FRS switch signal		
		Micro dust and pollen filter mode switch signal		
		Blower switch signal (FAN+, FAN-, OFF)		
		Set temperature switch signal (UP, DOWN)		

2. Remote Air Conditioning System

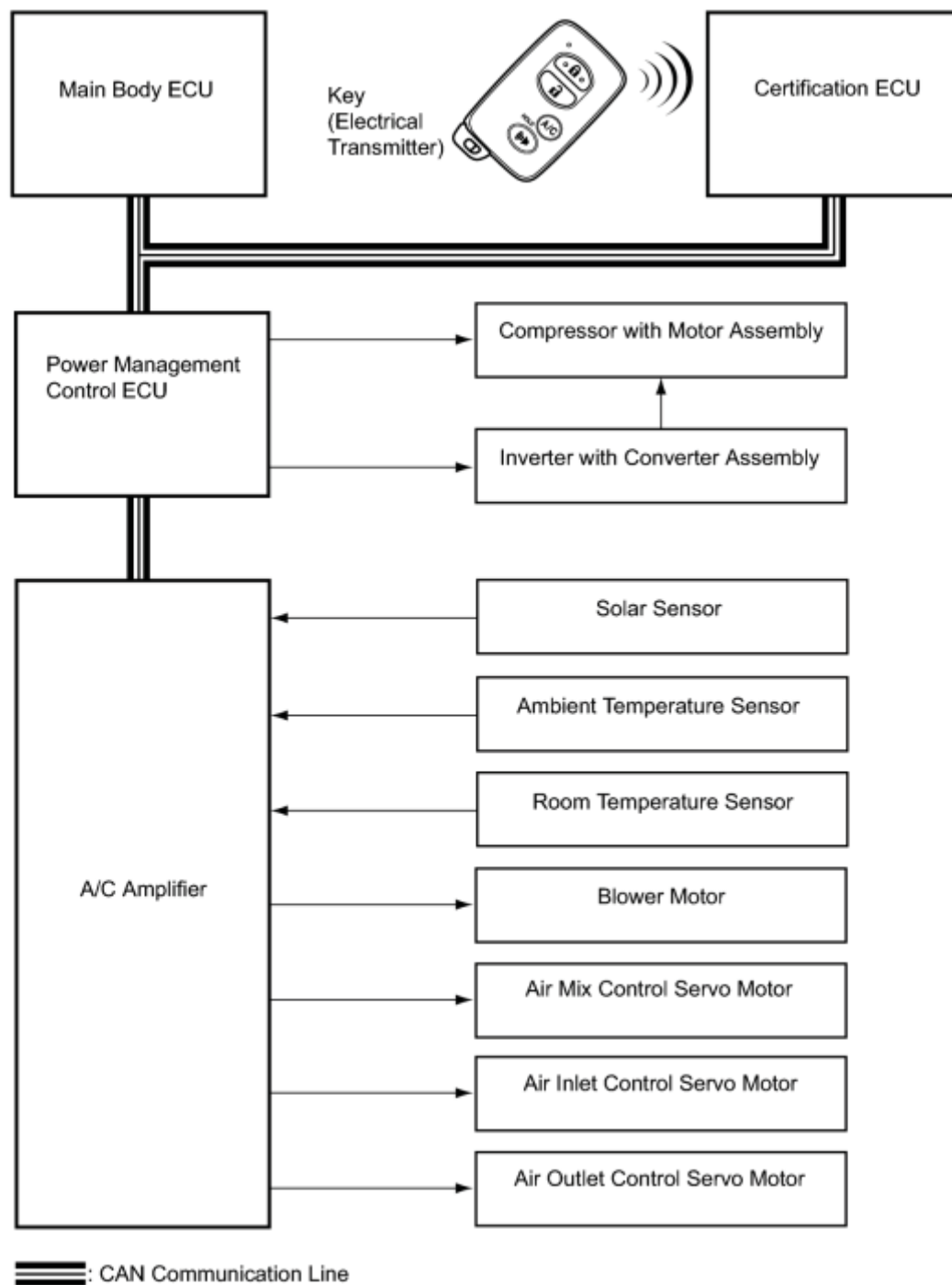

Communication Table

Sender	Receiver	Signal	Communication Line
Key (Electrical Transmitter)	Certification ECU	Remote air conditioning system activation request signal	Radio waves
		Remote air conditioning system stop	

Sender	Receiver	Signal	Communication Line
		request signal	
Certification ECU	Main Body ECU	Remote air conditioning system activation request signal	CAN
		Remote air conditioning system stop request signal	
Main Body ECU	Power Management Control ECU (Power Control Section)	Remote air conditioning system power ON/OFF request signal	CAN
		Remote air conditioning system mode notification signal	
	Power Management Control ECU (HV System Control Section)	HV system ON/OFF request signal	
		Remote air conditioning system mode notification signal	
	A/C amplifier	Remote air conditioning system mode notification signal	
	Certification ECU	Remote air conditioning system mode notification signal	
Power Management Control ECU (Power Control Section)	Main Body ECU	Power mode status signal	CAN
Power Management Control ECU (HV System Control Section)	Main Body ECU	Remote air conditioning system activation permission signal	CAN
		Remote air conditioning system activation prohibition signal	
	A/C Amplifier	Remote air conditioning system activation permission signal	
		Remote air conditioning system activation prohibition signal	
A/C Amplifier	Main Body ECU	Remote air conditioning system OFF request signal	CAN

HINT:

For details of the remote air conditioning system, refer to System Description .

SYSTEM DESCRIPTION

1. GENERAL

(a) The air conditioning system uses the following types of control.

Control		Outline
Neural Network Control		This control is capable of effecting complex control by artificially simulating the information processing method of the nervous system of living organisms in order to establish a complex input or output relationship that is similar to a human brain.
Outlet Air Temperature Control		In compliance with the temperature set at the temperature control switch, the neural network control calculates the outlet temperature based on the input signals from various sensors. In addition, corrections in accordance with the signals from the evaporative temperature sensor and water temperature sensor are added to control the outlet air temperature.
Blower Control		Controls the blower motor in accordance with the airflow volume that has been calculated by the neural network control based on the input signals from various sensors.
Air Outlet Control		Automatically switches the outlets in accordance with the outlet mode ratio that has been calculated by the neural network control based on the input signals from various sensors.
Micro Dust and Pollen Filter Mode Control		<ul style="list-style-type: none"> • Activated by the micro dust and pollen filter mode switch operation. • Switches the air vent to the FACE mode. • Sends air which has passed through the clean air filter to the area around the upper part of the bodies of the driver and front passenger. This air is filtered by the clean air filter in order to remove pollen.
Air Inlet Control		Automatically controls the air inlet control damper in accordance with the outlet temperature that has been calculated by the neural network control.
Electric Inverter Compressor Control	Compressor Speed Control	<p>The A/C amplifier calculates the target speed of the compressor based on the target evaporator temperature (which is calculated by the temperature control switch, room temperature sensor, ambient temperature sensor, and solar sensor) and the actual evaporator temperature that is detected by the evaporator temperature sensor in order to control the compressor speed.</p> <p>The A/C amplifier calculates the target evaporator temperature, which includes corrections based on the temperature control switch, room temperature sensor, ambient temperature sensor, solar sensor, and evaporator temperature sensor. Accordingly, the A/C amplifier controls the compressor speed to an extent that would not inhibit the proper cooling performance or defogging performance.</p>
PTC Heater Control*1		<p>When the hybrid control system is operating (READY), and the blower motor is turned on, the A/C amplifier turns on the PTC heater assembly if the conditions listed below are met:</p> <ul style="list-style-type: none"> • Engine coolant temperature is below specified temperature. • Outside temperature is below specified temperature • Tentative air mix damper opening angle is above the specified value (MAX

Control	Outline
	HOT).
Plasmacluster (Ion Generator) Control*2	The Plasmacluster generator is controlled by the air conditioning amplifier assembly and operates in conjunction with the blower with fan motor sub-assembly.
ECO Mode Control	When the ECO MODE switch is turned on, the A/C amplifier limits the air conditioning system performance.
Remote Air Conditioning System Control*3	When the remote A/C switch on the key (electrical transmitter) is pressed, the air conditioning system is automatically controlled and operated for a maximum of 3 minutes using power from the HV battery.

- *1: w/ PTC heater assembly
- *2: w/ Plasmacluster (ion generator)
- *3: w/ Remote air conditioning system

2. NEURAL NETWORK CONTROL

- In the previous automatic air conditioning systems, the A/C amplifier determined the required outlet air temperature and blower air volume in accordance with the calculation formula that has been obtained based on information received from the sensors.

However, because the senses of a person are rather complex, a given temperature is sensed differently, depending on the environment in which the person is situated. For example, a given amount of sunlight can feel comfortably warm in a cold climate, or extremely uncomfortable in a hot climate. Therefore, as a technique for effecting a higher level of control, a neural network has been adopted in the automatic air conditioning system. With this technique, the data that has been collected under varying environmental conditions is stored in the A/C amplifier. The A/C amplifier can then effect control to provide enhanced air conditioning comfort.

- The neural network control consists of neurons in the input layer, intermediate layer and output layer. The input layer neurons process the input data of the outside temperature, the amount of sunlight and the room temperature based on the outputs of the switches and sensors, and output them to the intermediate layer neurons. Based on this data, the intermediate layer neurons adjust the strength of the links among the neurons. The sum of these is then calculated by the output layer neurons in the form of the required outlet temperature, solar correction, target airflow volume and outlet mode control volume. Accordingly, the A/C amplifier controls the servo motors and blower motor in accordance with the control volumes that have been calculated by the neural network control.

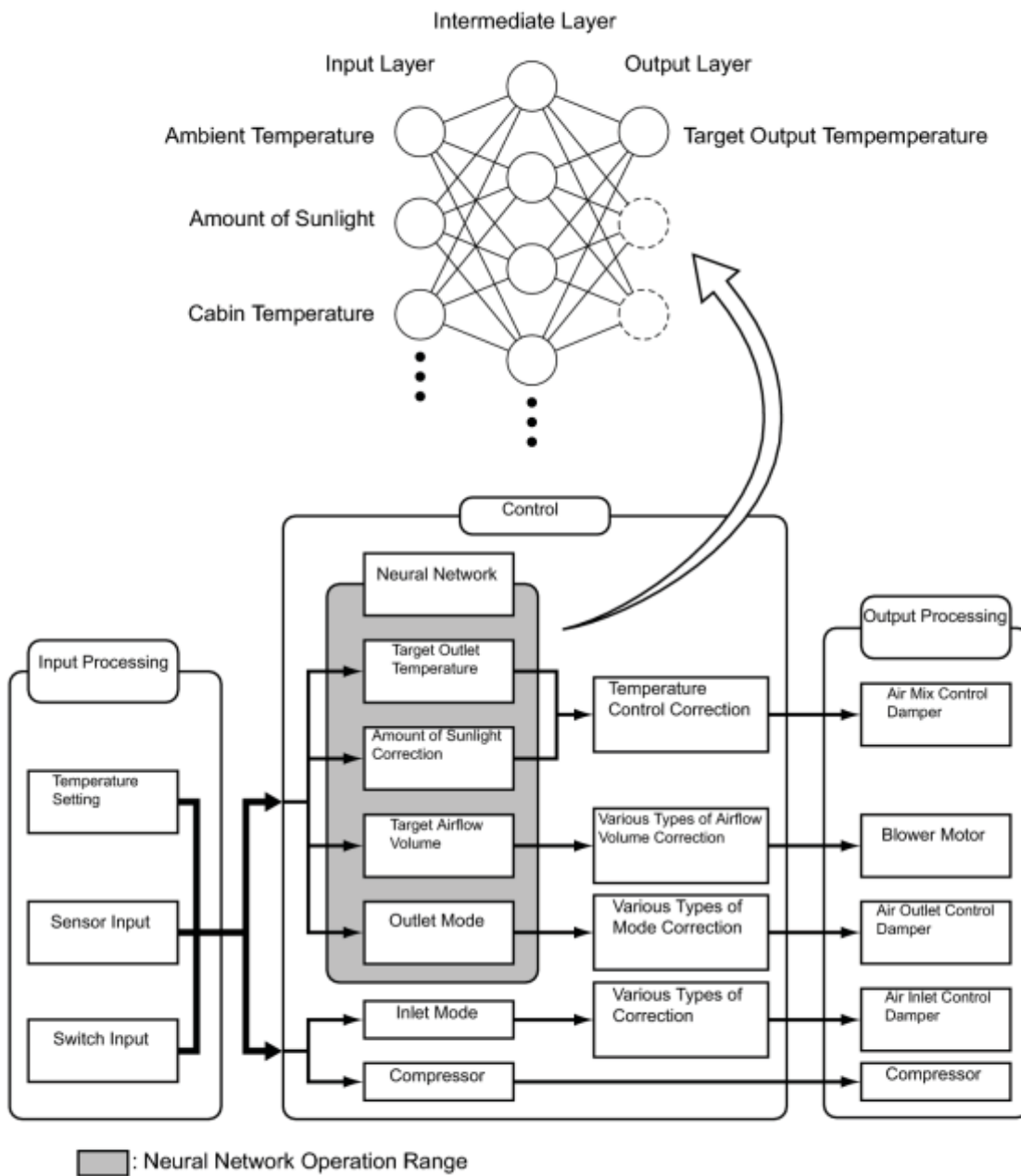

H



3. MODE POSITION AND DAMPER OPERATION

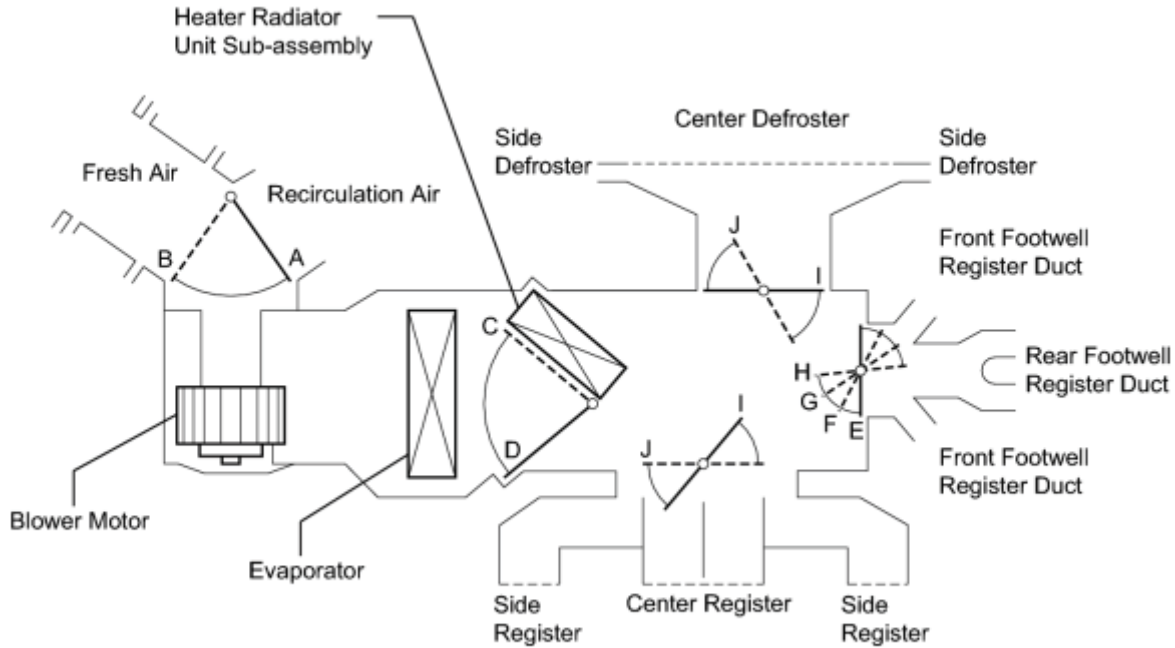

(a) Mode Position and Damper Operation



H

Functions of Main Dampers

Control Damper	Operation Position	Damper Position	Operation
Air Inlet Control Damper	FRESH	A	Allows fresh air to enter.
	RECIRCULATION	B	Causes internal air to recirculate.
Air Mix Control Damper	MAX COLD to MAX HOT Temperature Setting	C - D	Varies the mixture ratio of warm air and cool air in order to regulate the temperature continuously between hot and cold.
Air Outlet Control Damper	DEF 	J, E	Defrosts the windshield through the center defroster, side defroster and side registers.
	FOOT/DEF 	J, F	Defrosts the windshield through the center defroster, side defrosters, side registers while air is also blown out from the front and rear footwell register ducts.
	FOOT 	J, H	Air blows out of the front and rear footwell register ducts, and side registers. In addition, air blows out slightly from the center defroster and side defrosters.

Control Damper	Operation Position	Damper Position	Operation
	BI-LEVEL 	I, G	Air blows out of the front and rear center register, side register and front and rear footwell register ducts.
	FACE 	I, E	Air blows out of the front center register and side register ducts.



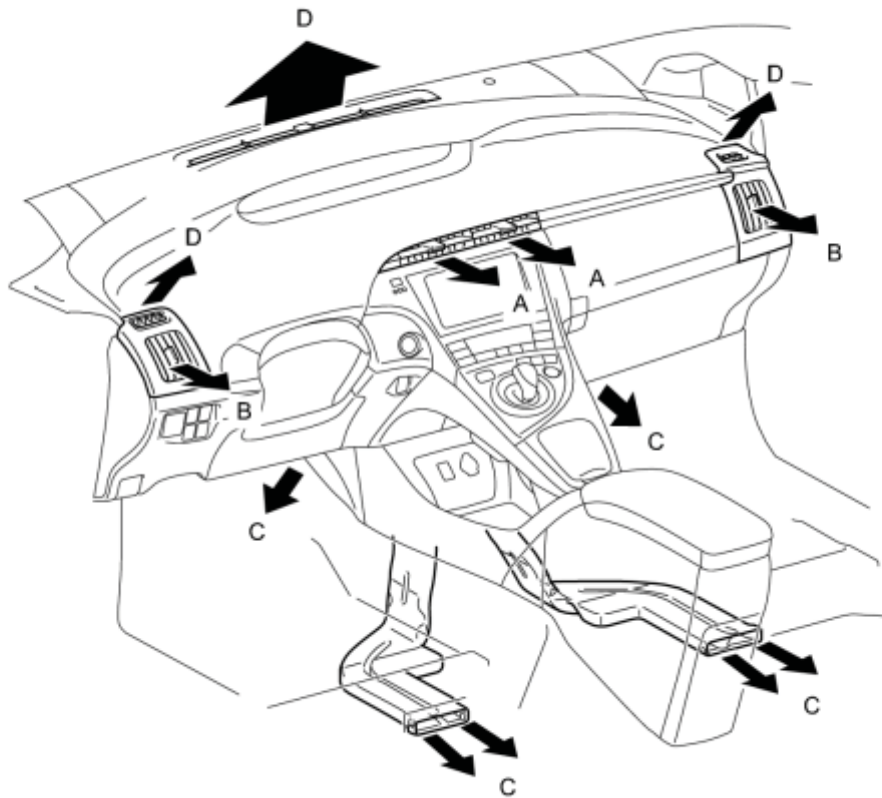

4. AIR OUTLETS AND AIRFLOW VOLUME

(a) Air Outlets and Airflow Volume



H

Indication	Mode	FACE		FOOT	DEF
		CTR	SIDE		
		A	B	C	D

Indication	Mode	FACE		FOOT	DEF
		CTR	SIDE	C	D
		A	B		
	FACE	○	○	—	—
	B/L	○	○	○	—
	FOOT	—	○	○	○
	F/D	—	○	○	○
	DEF	—	○	—	○

The size of each circle ○ indicates the ratio of airflow volume.

5. OUTLINE OF REMOTE AIR CONDITIONING SYSTEM

(a) Outline

(1) When the remote A/C switch on the key (electrical transmitter) is pressed, the air conditioning system is automatically controlled and operated for a maximum of 3 minutes using power from the HV battery.

HINT:

The remote air conditioning system starts operating when all of the following operating conditions are met:

Operating Condition

Item	Condition
Power switch	<ul style="list-style-type: none"> Off Power switch is not pressed
Door Lock	<ul style="list-style-type: none"> All doors are closed and locked. Hood is closed.
Brake Pedal	Not operated (not depressed)
Security	Not in alarm sounding state
Shift Selection	Park (P) is selected.
HV Battery	<p>HV battery state of charge is sufficient.</p> <p>(Reference value: level 3 or higher)</p>

Item	Condition
Cabin Temperature	<ul style="list-style-type: none"> Higher than air conditioning temperature set by user Air conditioning (cooling) is necessary

(b) Function of Main Components

(1) Each component of the remote air conditioning system has the functions described in the table:

Function of Main Components

Component	Outline
Key (electrical transmitter)	Sends remote air conditioning system on/off signals to the certification ECU.
Certification ECU	Receives a signal from the key (electrical transmitter) and sends a signal to the main body ECU.
Main body ECU	<ul style="list-style-type: none"> Locks all of the doors. Checks that all of the doors are closed and locked. Checks that the hood is closed. When the remote air conditioning system starts, the main body ECU operates the wireless door lock system.
Power management control ECU	<ul style="list-style-type: none"> Turns the vehicle power (12 V) on/off. Checks the state of charge of the HV battery. Starts/stops the HV system. Controls the inverter with converter assembly. Checks the power switch condition. Checks if park (P) is selected. Checks the brake pedal condition. Permits/prohibits remote air conditioning system operation.
A/C amplifier	<ul style="list-style-type: none"> Judges whether the cooling function is operating during remote air conditioning system operation. Checks the operation of the air conditioning system based on signals from various sensors. Controls the air conditioning system. Judges when to stop the remote air conditioning system.
Inverter with converter assembly	Supplies DC power from the HV battery to the inverter of the compressor with motor assembly.
Compressor with motor assembly	Compresses refrigerant using power from the HV battery.

6. EJECTOR CYCLE SYSTEM

(a) In the conventional refrigerant cycle, liquid refrigerant gas is sent into the evaporator using the expansion valve, generating cold air. However, a rapid decrease in the refrigerant pressure forms swirls, causing energy loss. In this ejector cycle, the energy loss caused by the cooler expansion valve is utilized by the operation of the ejector that injects and expands a high-pressure refrigerant, thus improving energy consumption efficiency.

(b) The ejector includes nozzle, mixing and diffuser portions.

(c) A high temperature and pressure liquid refrigerant flowing from the condenser is introduced into the mixing section through the nozzle at high speeds as the nozzle is inwardly tapered. This decreases the refrigerant pressure in the vicinity of the nozzle, introducing low temperature and pressure gaseous refrigerant into the nozzle from the evaporator. Thus, both refrigerants are mixed in the mixing section and are introduced into the diffuser section.

(d) As the diffuser section is outwardly flared, the refrigerant flow rate in the diffuser decreases and the refrigerant pressure rises.

(e) Through these operations, the refrigerant pressure in the evaporator on the downwind side can be constantly kept lower than that on the upwind side, creating the lower temperature conditions. Therefore, air cooled by the evaporator on the upwind side can be further cooled by that on the downwind side, thus improving the efficiency of the evaporator.

7. MICRO DUST AND POLLEN FILTER MODE CONTROL

(a) When the micro dust and pollen filter mode switch is pressed, the micro dust and pollen filter mode control is activated.

(b) Then, the air vent is switched to the FACE mode and recirculated pollen-free air flows in the area around the upper part of the bodies of the driver and front passenger.

(c) When the micro dust and pollen filter mode switch signal is input to the A/C amplifier, the A/C amplifier controls the compressor with motor assembly, air inlet control servo motor, air outlet control servo motor and blower motor as shown in the timing chart below.

(d) This control usually operates for approximately 3 minutes. However, when the outside temperature is low (5°C (41°F) maximum), it will operate for approximately 1 minute.

(e) After this control stops operating, the A/C amplifier controls the air conditioning system using AUTO mode.

Timing Chart:
(Sample)

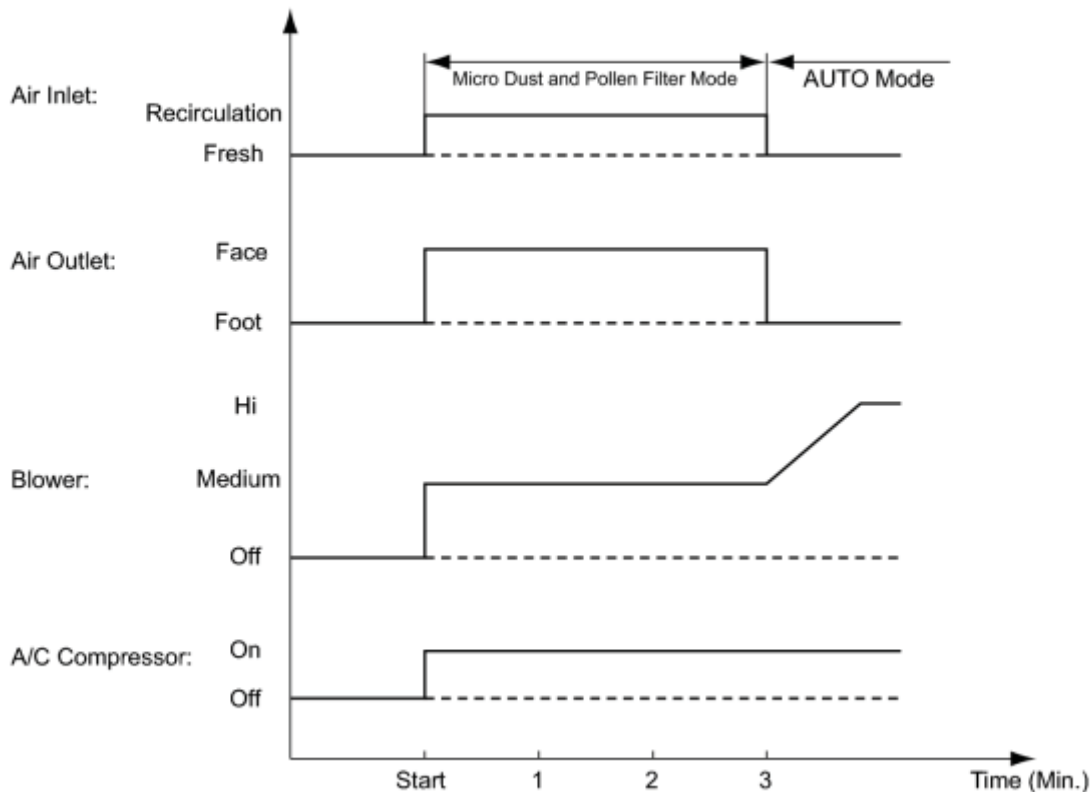

H

8. PLASMACLUSTER (ION GENERATOR) CONTROL (w/ Plasmacluster (Ion Generator))

(a) General:

(1) A Plasmacluster (ion generator) is provided inside the air duct of the side register on the driver seat side to improve the air quality and comfort in the cabin.

(2) This generator is controlled by the A/C amplifier and operates in conjunction with the blower motor.

NOTICE:

- The Plasmacluster (ion generator) uses a high voltage, which is hazardous. Therefore, if the Plasmacluster (ion generator) requires repairs, be sure to have them done at a TOYOTA dealer.
- Do not apply any type of spray (such as a cleaning solvent or hair spray) or stick any foreign matter into the Plasmacluster ion outlet, as this could cause improper operation or a malfunction.
- After use, dust may accumulate around the side register on the driver seat side. If this occurs, press the OFF switch on the A/C control assembly to stop the blower motor before cleaning the area.
- It is normal for the Plasmacluster (ion generator) to emit a slight sound during operation. This sound is created when electrons collide with the electrode while Plasmacluster ions are being generated.

HINT:

Plasmacluster™, plasmacluster, and plasmacluster ions are a trademark of the SHARP Corporation.

(b) Operation:

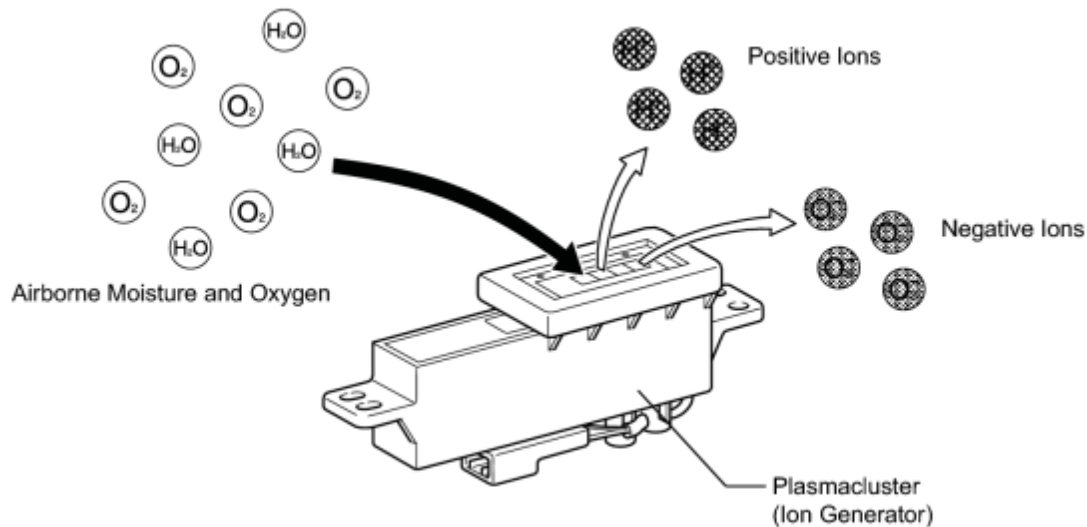

H

(1) The Plasmacluster (ion generator) produces positive and negative ions from the water molecules (H₂O) and oxygen molecules (O₂) in the air, and emits them into the air. These ions reduce airborne germs.

9. ECO MODE CONTROL

(a) Under the control of eco mode, the A/C amplifier restricts the air conditioning system performance under specified conditions, thus improving fuel economy.

(b) Eco mode control is activated when the ECO MODE switch provided inside the integration control and panel sub-assembly is pressed, and then restricts the air conditioning system performance as described below.

Control	Outline
Inside/outside Air Switch Control	Automatically switches the air inlet port to internal air circulation mode when the outside air temperature is equal to or higher than a predetermined temperature and reduces the power consumption.
Blower Level Control	Sets the blower level in AUTO mode lower than normal, and suppresses the power consumption.
PTC Heater Control	Stops the operation of PTC heater assembly and suppresses the power consumption.
Heating Restriction Control	Changes the air outlet temperature by turning the ECO MODE switch on and off during heating and increases the amount of engine-off time when the ECO MODE switch is in the on state, thus improving fuel economy.
Compressor Speed Restriction Control	Restricts the maximum speed during cooling and reduces the power consumption.

10. COMPRESSOR WITH MOTOR ASSEMBLY

(a) Compressor Control

HINT:

In order to ensure the proper insulation of the internal high-voltage portion of the compressor and the compressor housing, this vehicle has adopted compressor oil (ND11) with a high level of insulation performance. Therefore, never use compressor oil other than the ND11 type compressor oil or its equivalent.

(1) The A/C amplifier calculates the target compressor speed based on the target evaporator temperature (calculated from the temperature control switch, room temperature sensor, ambient temperature sensor, and solar sensor) and the actual evaporator temperature detected by the evaporator temperature sensor. Then, the A/C amplifier transmits the target speed to the power management control ECU. The power management control ECU controls the A/C inverter based on the target speed data in order to control the compressor with motor assembly to a speed that suits the operating condition of the air conditioning system.

(2) The A/C amplifier calculates the target evaporator temperature, which includes corrections based on the temperature control switch, room temperature sensor, ambient temperature sensor, automatic light control sensor, and evaporator temperature sensor. Accordingly, the A/C amplifier controls the compressor speed to an extent that does not inhibit the proper cooling performance or defogging performance.

(3) The compressor with motor assembly uses high-voltage alternating current. If a short or open circuit occurs in the compressor with motor assembly wiring harness, the power management control ECU will cut off the A/C inverter circuit in order to stop the power supply to the compressor motor.

11. PTC HEATER (w/ PTC Heater Assembly)

(a) General

(1) The PTC heater assembly is located above the heater core in the air conditioning unit.

(2) The PTC heater assembly consists of a PTC element, aluminum fin, and brass plate. When current is applied to the PTC element, it generates heat to warm the air that passes through the unit.

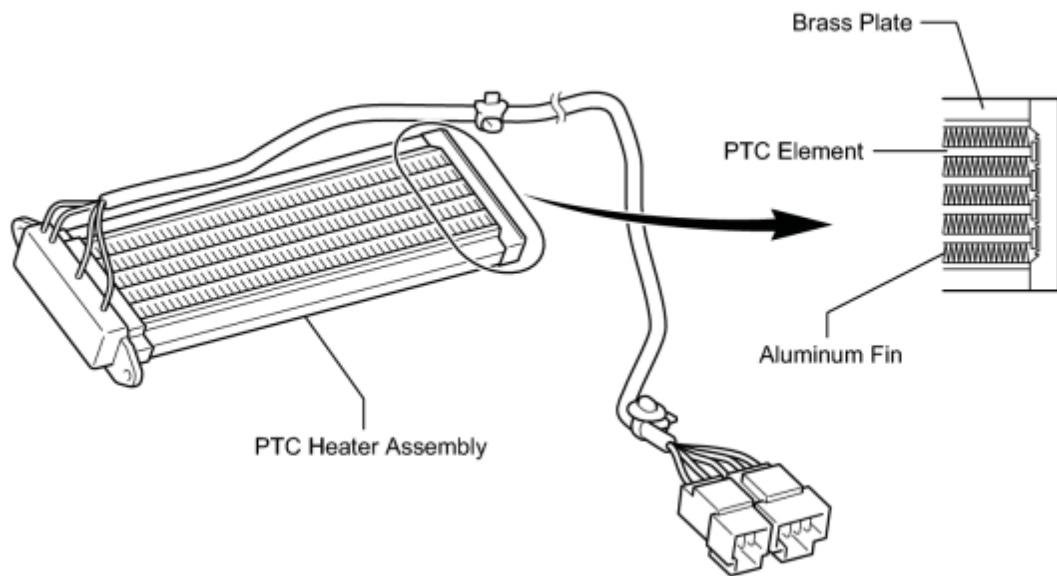

(b) PTC Heater Assembly Operating Conditions

(1) The PTC heater assembly is turned on and off by the A/C amplifier in accordance with the engine coolant temperature, ambient temperature, engine speed, temperature setting, and electrical load (generator power ratio).

12. BLOWER MOTOR

The blower motor has a built-in blower controller, and is controlled using duty control performed by the A/C amplifier.

13. BUS CONNECTOR (AIR CONDITIONING HARNESS)

(a) A Bus connector is used in the wire harness connection that connects the servo motor from the A/C amplifier.

Example:

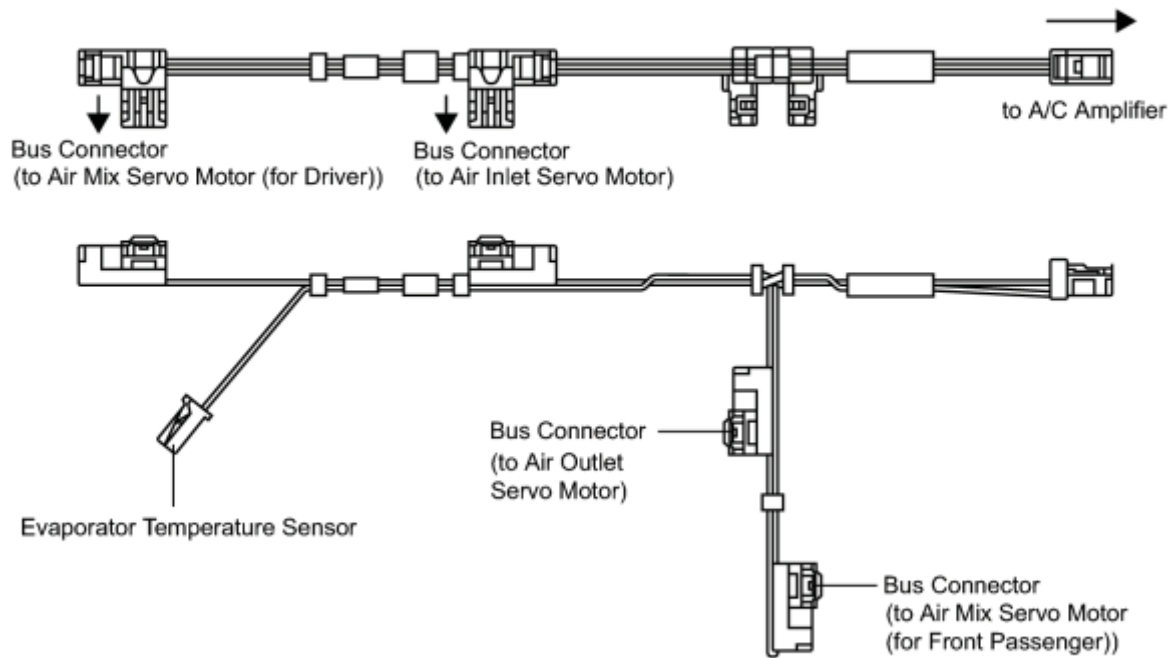

H

(b) Each Bus connector has a built-in communication/driver IC which communicates with each servo motor connector, actuates the servo motor, and has a position detection function. This enables bus communication for the servo motor wire harness, for a more lightweight construction and a reduced number of wires.

w/ Bus Connector:

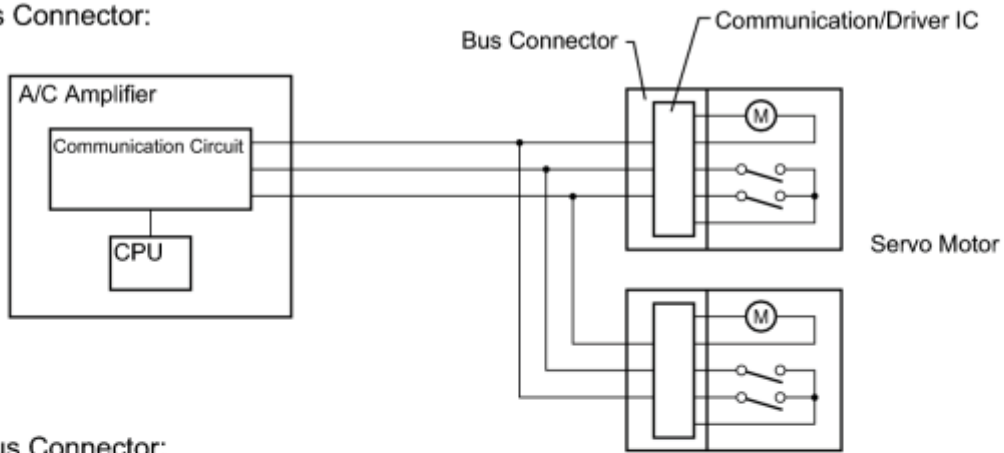

w/o Bus Connector:

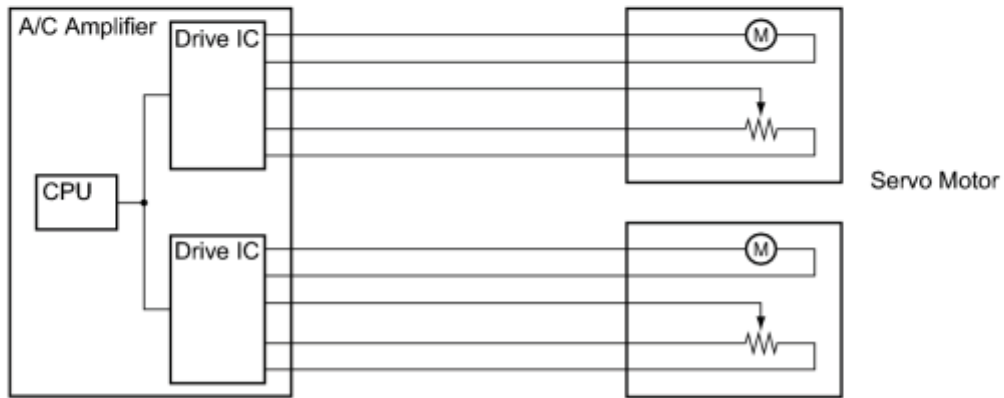

H

14. SERVO MOTOR

The pulse pattern type servo motor consists of a printed circuit board and a servo motor. The printed circuit board has three contact points, and can transmit two ON-OFF signals to the A/C amplifier based on the difference of the pulse phases. The BUS connector can detect the damper position and movement direction with these signals.

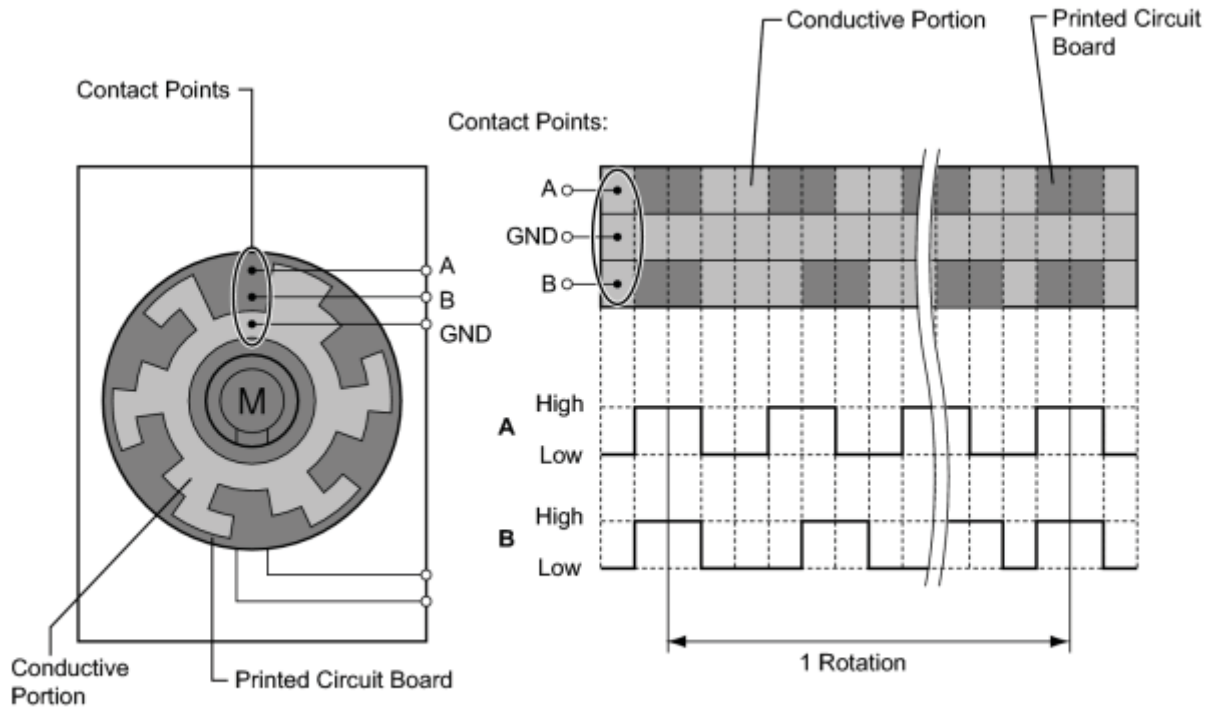

H

15. EVAPORATOR TEMPERATURE SENSOR

The evaporator temperature sensor detects the temperature of the cool air immediately through the evaporator in the form of resistance changes, and outputs it to the A/C amplifier.

16. ROOM TEMPERATURE SENSOR

The room temperature sensor detects the cabin temperature based on changes in the resistance of its built-in thermistor and sends a signal to the A/C amplifier.

17. AMBIENT TEMPERATURE SENSOR

The ambient temperature sensor detects the outside temperature based on changes in the resistance of its built-in thermistor and sends a signal to the A/C amplifier.

18. SOLAR SENSOR (AUTOMATIC LIGHT CONTROL SENSOR)

The solar sensor (automatic light control sensor) detects the changes in the amount of sunlight and outputs it to the A/C amplifier in the form of voltage changes.

19. A/C PRESSURE SENSOR

The A/C pressure sensor detects the refrigerant pressure and outputs it to the A/C amplifier in the form of voltage changes.

HOW TO PROCEED WITH TROUBLESHOOTING

HINT:

- Use the following procedure to troubleshoot the air conditioning system.
- *: Use the Techstream.

1. VEHICLE BROUGHT TO WORKSHOP

NEXT



2. INSPECT BATTERY VOLTAGE

(a) Inspect the battery voltage with the power switch off.

Standard Voltage:

11 to 14 V

If the voltage is below 11 V, recharge or replace the battery before proceeding to the next step.

NEXT



3. CHECK COMMUNICATION FUNCTION OF LIN COMMUNICATION SYSTEM*

(a) Use the Techstream to check if the LIN communication system is functioning normally.

Result:

Result	Proceed to
LIN DTC is not output	A
LIN DTC is output	B

B ▶ GO TO LIN COMMUNICATION SYSTEM

A



4. CHECK COMMUNICATION FUNCTION OF CAN COMMUNICATION SYSTEM*

(a) Use the Techstream to check if the CAN communication system is functioning normally.

Result:

Result	Proceed to
CAN DTC is not output	A

Result	Proceed to
CAN DTC is output	B 

B  GO TO CAN COMMUNICATION SYSTEM

A

5.	CHECK FOR DTC*
----	----------------

(a) Check for DTCs and note any code that is output.

(b) Clear the DTCs.

(c) Recheck for DTCs. Based on the DTCs output above, try to force the A/C system to output DTCs by simulating the conditions indicated by the DTC.

Result:

Result	Proceed to
DTC is output	A
DTC is not output	B

B  Go to step 7

A

6.	DIAGNOSTIC TROUBLE CODE CHART
----	-------------------------------

(a) Find the output code in the diagnostic trouble code chart .

NEXT  Go to step 9

7.	PROBLEM SYMPTOMS TABLE
----	------------------------

(a) Refer to Problem Symptoms Table .

Result:

Result	Proceed to
Fault is not listed in Problem Symptoms Table	A
Fault is listed in Problem Symptoms Table	B

B  Go to step 9

A

8.	OVERALL ANALYSIS AND TROUBLESHOOTING*
----	---------------------------------------

(a) Panel diagnosis (indicator check, sensor check) .

(b) Data List / Active Test 

(c) Terminals of ECU 

(d) Operation Check  (w/ Remote Air Conditioning System))

(e) On-vehicle Inspection

(f) Inspection

NEXT



9.	ADJUST, REPAIR OR REPLACE
----	---------------------------

NEXT  **END**

OPERATION CHECK

1. OPERATION CHECK OF REMOTE AIR CONDITIONING SYSTEM

HINT:

The remote air conditioning system does not operate unless the required operating conditions are met. Therefore, confirm that the operating conditions are met before performing the inspection .

(a) Activation Control Check

(1) Press and hold the remote A/C switch on the key (electrical transmitter) once for 1 seconds or more to start the air conditioning system.

HINT:

The wireless door lock system locks all doors before the remote air conditioning system is activated.

(b) Operation Check

(1) Check that the remote air conditioning system operates for a maximum of 3 minutes.

HINT:

The operating time differs depending on the HV battery state of charge.

(c) Stop Control Check

(1) Press the remote A/C switch on the key (electrical transmitter) twice briefly within 3 seconds to stop the remote air conditioning system.

HINT:

- When any of the operating conditions are not met during remote air conditioning system operation, the remote air conditioning system will stop.
- When 3 minutes have elapsed after the remote air conditioning system was started, the remote air conditioning system will stop. Some operating conditions may result in the remote air conditioning system being stopped before 3 minutes elapses.

(d) Operation Check of the Remote A/C Switch on the Key (Electrical Transmitter)

NOTICE:

- Use 2 keys (electrical transmitters).
- Confirm that the wireless door lock functions operate normally.

(1) Prepare 2 registered keys (electrical transmitters), and label one of them key (electrical transmitter) A, and the other key (electrical transmitter) B.

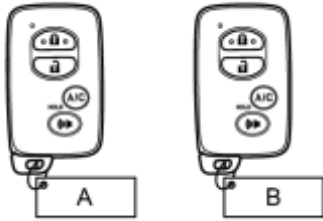

(2) Operate the remote A/C switch on key (electrical transmitter) A and check that the remote air conditioning system can be operated.

(3) Operate the remote A/C switch on key (electrical transmitter) B and check that the remote air conditioning system can be operated.

HINT:

- If the remote air conditioning system is not operated for both keys (electrical transmitters) A and B, the remote air conditioning system may have a malfunction **INFO**.
- If the remote air conditioning system is not operated for one of the keys (electrical transmitter) A or B, the key (electrical transmitter) needs to be replaced because a malfunction of the remote A/C switch on the key (electrical transmitter) is suspected.

CUSTOMIZE PARAMETERS

HINT:

The following items can be customized.

NOTICE:

- When the customer requests a change in a function, first make sure that the function can be customized.
- Be sure to make a note of the current settings before customizing.
- When troubleshooting a function, first make sure that the function is set to the default setting.

Air Conditioner

Display (Item)	Default	Content	Setting
Set Temperature Shift	Normal	Function to control with the shifted temperature against the displayed temperature.	+2 C, +1 C, Normal, -1 C or -2 C
Compressor Mode	Automatic	Function to automatically turn the A/C on by pressing the AUTO button when blower is on and the A/C is off.	Manual or Automatic
Air Inlet Mode	Automatic	Function to shift from INLET mode to RECIRCULATION mode when the A/C is turned on.	Manual or Automatic
Foot/DEF Auto Mode	ON	Function to automatically turn the airflow from FOOT/DEF on when AUTO mode is on.	OFF or ON
Foot/DEF Automatic Blow Up Function	ON	Function to automatically increase the blower level when the defroster is on.	OFF or ON
Ambient Temperature Shift	Normal	Function to control the shifted ambient temperature in relation to the displayed ambient temperature.	+3 C, +2 C, +1 C, Normal, -1 C, -2 C or -3 C
ECO MODE Cancel	OFF	Function to cancel the ECO mode drive when item is on.	OFF or ON
Noise and Vibration Reduction	OFF	Function to change speed of the compressor when item is on.	OFF or ON
Start Pre A/C*1	Long1	Function to set the activation operation method for the remote air conditioning system using the key (electrical transmitter).	1 tim ON, 2 tim ON, Long1 or Long2
Stop Pre A/C*1	2 tim ON	Function to set the stop operation method for the remote air conditioning system using the key (electrical transmitter).	1 tim ON, 2 tim ON, Long1 or Long2

- *1: w/ Remote Air Conditioning System

PROBLEM SYMPTOMS TABLE

HINT:

- Use the table below to help determine the cause of problem symptoms. If multiple suspected areas are listed, the potential causes of the symptoms are listed in order of probability in the "Suspected Area" column of the table. Check each symptom by checking the suspected areas in the order they are listed. Replace parts as necessary.
- Inspect the fuses and relays related to this system before inspecting the suspected areas below.

Air Conditioning System

Symptom	Suspected Area	See page
All functions of the A/C system do not operate	IG power source circuit	INFO
	Back-up power source circuit	INFO
	Air conditioning control panel circuit	INFO
	A/C amplifier	INFO
Air flow control: No blower operation	Blower motor circuit	INFO
	Air conditioning control panel circuit	INFO
	A/C amplifier	INFO
Air flow control: No blower control	Blower motor circuit	INFO
	Air conditioning control panel circuit	INFO
	A/C amplifier	INFO
Air flow control: Insufficient air flow	Blower motor circuit	INFO
	A/C amplifier	INFO
The blower motor operates by itself or the motor speed changes arbitrarily (Speed does not change in accordance with automatic or manual control settings)*1	IG signal circuit	INFO
	Solar ventilation ECU	INFO
Temperature control: No cool air comes out	Refrigerant volume	INFO
	Refrigerant pressure	INFO
	Air conditioning pressure sensor circuit	INFO
	Air mix damper control servo motor circuit	INFO
	Evaporator temperature sensor circuit	INFO
	Room temperature sensor circuit	INFO
	Ambient temperature sensor circuit	INFO

Symptom	Suspected Area	See page
	Air conditioning control panel circuit	INFO
	Expansion valve	INFO
	CAN communication system	INFO
	A/C amplifier	INFO
	No. 2 engine wire	INFO
	Compressor with motor assembly	INFO
	Power management control ECU	INFO
Temperature control: No warm air comes out	Air mix damper control servo motor circuit	INFO
	Engine coolant temperature sensor circuit	INFO
	Evaporator temperature sensor circuit	INFO
	Room temperature sensor circuit	INFO
	Ambient temperature sensor circuit	INFO
	Air conditioning control panel circuit	INFO
	PTC heater circuit*2	INFO
	CAN communication system	INFO
	Radiator unit sub-assembly	INFO
	A/C amplifier	INFO
ECM	INFO	
Temperature control: Output air is warmer or cooler than the set temperature or response is slow	Refrigerant volume	INFO
	Refrigerant pressure	INFO
	Solar sensor circuit	INFO
	Room temperature sensor circuit	INFO
	Ambient temperature sensor circuit	INFO
	Evaporator temperature sensor circuit	INFO
	Air mix damper control servo motor circuit	INFO

Symptom	Suspected Area	See page
	Air inlet damper control servo motor circuit	INFO
	PTC heater circuit*2	INFO
	Air conditioning control panel circuit	INFO
	Radiator unit sub-assembly	INFO
	Expansion valve	INFO
	CAN communication system	INFO
	A/C amplifier	INFO
	No. 2 engine wire	INFO
	Compressor with motor assembly	INFO
	ECM	INFO
	Power management control ECU	INFO
Temperature control: No temperature control (only Max. cool or Max. warm)	Air mix damper control servo motor circuit	INFO
	Room temperature sensor circuit	INFO
	Ambient temperature sensor circuit	INFO
	Evaporator temperature sensor circuit	INFO
	Solar sensor circuit	INFO
	Air conditioning control panel circuit	INFO
	A/C amplifier	INFO
No air inlet control	Air inlet damper control servo motor circuit	INFO
	Air conditioning control panel circuit	INFO
	A/C amplifier	INFO
No air flow mode control	Air outlet damper control servo motor circuit	INFO
	Air conditioning control panel circuit	INFO
	A/C amplifier	INFO
Heater performance is low (engine is stopped)*2	PTC heater circuit	INFO
	A/C amplifier	INFO

Symptom	Suspected Area	See page
Plasmacluster does not operate*3	Blower motor circuit	INFO
	Plasmacluster circuit	INFO
	A/C amplifier	INFO
ECO MODE switch indicator does not come on (ECO MODE switch does not operate)	ECO switch circuit	INFO
	A/C amplifier	INFO
Micro dust and pollen filter mode does not operate (A/C system is operating normally)	Air inlet damper control servo motor circuit	INFO
	Air outlet damper control servo motor circuit	INFO
	Blower motor circuit	INFO
	Air conditioning control panel circuit	INFO
	A/C amplifier	INFO
Unable to control A/C with the steering pad switch	Steering pad switch circuit	INFO
	Air conditioning control panel circuit	INFO
	A/C amplifier	INFO
Diagnostic trouble codes (DTCs) are not recorded. Set mode is cleared when power switch is off.	Back-up power source circuit	INFO
	A/C amplifier	INFO

Remote Air Conditioning System*4

Symptom	Suspected Area	See page
The remote air conditioning system does not operate when the remote A/C switch on the key (electrical transmitter) is pressed. (air conditioning system is normal)	Wireless door lock control system	INFO
	Data List (FL Door Courtesy, FR Door Courtesy, RL Door Courtesy SW, RR Door Courtesy SW, Back Door Courtesy SW)	INFO
	Data List (Hood Courtesy SW)	INFO
	Data List (Start Switch1, Start Switch2)	INFO
	Data List (IG SW, ACC SW)	INFO
	Data List (FL Door Lock Pos, FR Door Lock Pos, RL-Door Lock Pos SW, RR-Door Lock Pos SW)	INFO
	Operation check (key (electrical transmitter))	INFO
	Use simulation method to check	INFO
The remote air conditioning system does not operate even though a wireless door lock is performed when the remote A/C switch on the key (electrical transmitter) is pressed. (air	Data List (FL Door Courtesy, FR Door Courtesy, RL Door Courtesy SW, RR Door Courtesy SW, Back Door Courtesy	INFO

Symptom	Suspected Area	See page
conditioning system is normal)	SW)	
	Data List (Hood Courtesy SW)	INFO
	Data List (Start Switch1, Start Switch2)	INFO
	Data List (IG SW, ACC SW)	INFO
	Data List (Stop Light Switch)	INFO
	Data List (Shift Position)	INFO
	Use simulation method to check	INFO
The remote air conditioning system stops operating shortly after the system starts.	Operation check	INFO
	Use simulation method to check	INFO
The remote air conditioning system starts operating by itself.	Use simulation method to check	INFO
	Operation check (activation control, stop control, key (electrical transmitter))	INFO
	Certification ECU	INFO
	A/C amplifier	INFO
	Power management control ECU	INFO
The remote air conditioning system cannot be stopped using the remote A/C switch on the key (electrical transmitter).	Customize (Stop Pre A/C)	INFO
	Operation check (stop control, key (electrical transmitter))	INFO
	A/C amplifier	INFO
	Power management control ECU	INFO
	Certification ECU	INFO

- *1: w/ Solar Ventilation System
- *2: w/ PTC Heater Assembly
- *3: w/ Plasmacluster (Ion Generator)
- *4: w/ Remote Air Conditioning System

TERMINALS OF ECU

1. A/C AMPLIFIER

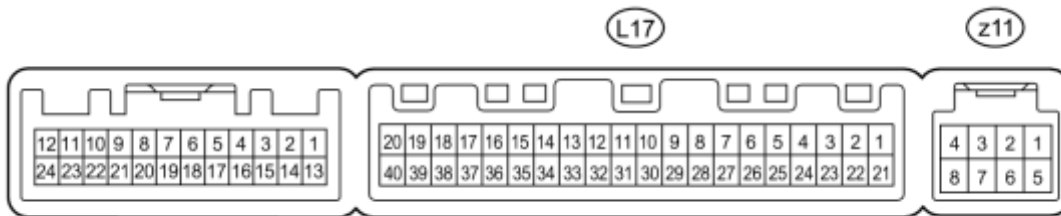

H

HINT:

Check from the rear of the connector while it is connected to the A/C amplifier.

Terminal No. (Symbol)	Wiring Color	Terminal Description	Condition	Specified Condition
L17-1 (IG+) - L17-14 (GND)	B - W-B	Power source (IG)	Power switch on (IG)	11 to 14 V
L17-1 (IG+) - L17-14 (GND)	B - W-B	Power source (IG)	Power switch off	Below 1 V
L17-5 (TAM) - L17-13 (SG- 2)	BE - G	Ambient temperature sensor signal	Power switch on (IG) Ambient temperature: 25°C (77°F)	1.35 to 1.75 V
L17-5 (TAM) - L17-13 (SG- 2)	BE - G	Ambient temperature sensor signal	Power switch on (IG) Ambient temperature: 40°C (104°F)	0.9 to 1.2 V
L17-9 (PRE) - L17-13 (SG-2)	L - G	A/C pressure sensor signal	Engine started, A/C system operating, Refrigerant pressure: Abnormal pressure (more than 3140 kPa (32.0 kgf/cm ² , 455 psi))	4.84 V or higher
L17-9 (PRE) - L17-13 (SG-2)	L - G	A/C pressure sensor signal	Engine started, A/C system operating, Refrigerant pressure: Abnormal pressure (less than 196 kPa (2.0 kgf/cm ² , 28 psi))	Below 0.73 V
L17-9 (PRE) - L17-13 (SG-2)	L - G	A/C pressure sensor signal	Engine started, A/C system operating, Refrigerant pressure: Normal pressure (less than 3140 kPa (32.0 kgf/cm ² , 455 psi) and more than 196 kPa (2.0 kgf/cm ² , 28 psi))	0.73 to 4.84 V
L17-10 (S5-3) - L17-13 (SG- 2)	B - G	Power supply for A/C pressure sensor	Power switch on (IG) A/C switch on	4.75 to 5.25 V

Terminal No. (Symbol)	Wiring Color	Terminal Description	Condition	Specified Condition
L17-10 (S5-3) - L17-13 (SG-2)	B - G	Power supply for A/C pressure sensor	Power switch on (IG) A/C switch off	Below 1 V
L17-11 (CANH)	Y	CAN communication system	-	-
L17-12 (CANL)	BR	CAN communication system	-	-
L17-13 (SG-2) - Body ground	G - Body ground	Ground for A/C pressure sensor, A/C ambient temperature sensor	Always	Below 1 V
L17-14 (GND) - Body ground	W-B - Body ground	Ground for main power supply	Always	Below 1 V
L17-15 (ECOS) - L17-14 (GND)	G - W-B	ECO MODE switch signal	Power switch on (IG) ECO MODE switch off	11 to 14 V
L17-15 (ECOS) - L17-14 (GND)	G - W-B	ECO MODE switch signal	Power switch on (IG) ECO MODE switch on	Below 1 V
L17-16 (PTC3) - L17-14 (GND)*1	BR - W-B	PTC heater operation signal	Engine is running (1250 rpm or higher) Temperature setting: MAX. HOT Ambient temperature: 10°C (50°F) or lower Engine coolant temperature: 65°C (149°F) or lower Light control switch off Blower switch on	11 to 14 V
L17-17 (PCD1) - L17-14 (GND)*3	LG - W-B	Plasmacluster operation signal	Power switch on (IG) Blower switch off (plasmacluster not operating)	11 to 14 V
L17-17 (PCD1) - L17-14 (GND)*3	LG - W-B	Plasmacluster operation signal	Power switch on (IG) Blower switch on (plasmacluster operating)	Below 1 V
L17-18 (PTC1) - L17-14 (GND)*1	W - W-B	PTC heater operation signal	Engine is running (1250 rpm or higher)	11 to 14 V

Terminal No. (Symbol)	Wiring Color	Terminal Description	Condition	Specified Condition
			Temperature setting: MAX. HOT Ambient temperature: 10°C (50°F) or lower Engine coolant temperature: 75°C (167°F) or lower Light control switch off Blower switch on	
L17-21 (B) - L17-14 (GND)	Y - W-B	Power source (Back-up)	Power switch off	11 to 14 V
L17-23 (BLW) - L17-14 (GND)	W - W-B	Blower motor speed control signal	Power switch on (IG) Blower switch LO	Pulse generation (See waveform 1)
L17-25 (PVSW) - L17-14 (GND)*2	P - W-B	Solar ventilation switch signal	Solar ventilation switch off	4.5 to 5.5 V
L17-25 (PVSW) - L17-14 (GND)*2	P - W-B	Solar ventilation switch signal	Solar ventilation switch on	Below 1 V
L17-26 (SSLR) - L17- 14 (GND)*2	L - W-B	Solar ventilation ECU status signal	Power switch on (IG) SBI terminal: 7 V or higher Solar ventilation system: off	Pulse generation (See waveform 2)
L17-27 (IDH) - L17-14 (GND)*1	L - W-B	Inverter with converter assembly current over signal	Power switch on (IG)	Pulse generation
L17-29 (TR) - L17-34 (SG-1)	B - W	Room temperature sensor signal	Power switch on (IG) Cabin temperature: 25°C (77°F)	1.8 to 2.2 V
L17-29 (TR) - L17-34 (SG-1)	B - W	Room temperature sensor signal	Power switch on (IG) Cabin temperature: 40°C (104°F)	1.2 to 1.6 V
L17-33 (TS) - L17-14 (GND)	BR - W- B	Solar sensor signal	Power switch on (IG) Solar sensor subjected to electric light	0.8 to 4.3 V

Terminal No. (Symbol)	Wiring Color	Terminal Description	Condition	Specified Condition
L17-33 (TS) - L17-14 (GND)	BR - W- B	Solar sensor signal	Power switch on (IG) Solar sensor covered with a cloth	Below 0.8 V
L17-34 (SG-1) - Body ground	W - Body ground	Ground for room temperature sensor	Always	Below 1 V
L17-36 (PCSW) - L17-14 (GND)*3	P - W-B	Plasmacluster switch signal	Power switch on (IG) Blower switch off (plasmacluster not operating)	11 to 14 V
L17-36 (PCSW) - L17-14 (GND)*3	P - W-B	Plasmacluster switch signal	Power switch on (IG) Blower switch on (plasmacluster operating)	Below 1 V
L17-37 (LIN1) - L17-14 (GND)	V - W-B	LIN communication signal	Power switch on (IG)	Pulse generation
L17-38 (PTC2) - L17- 14 (GND)*1	B - W-B	PTC heater operation signal	Engine is running (1250 rpm or higher) Temperature setting: MAX. HOT Ambient temperature: 10°C (50°F) or lower Engine coolant temperature: 65°C (149°F) to 70°C (158°F) Light control switch off Blower switch on	11 to 14 V
z11-2 (BUS G) - Body ground	-	Ground for BUS IC	Always	Below 1 V
z11-3 (BUS) - z11-2 (BUS G)	-	BUS IC control signal	Power switch on (IG)	Pulse generation
z11-4 (B BUS) - z11-2 (BUS G)	-	Power supply for BUS IC	Power switch off	Below 1 V
z11-4 (B BUS) - z11-2 (BUS G)	-	Power supply for BUS IC	Power switch on (IG)	11 to 14 V
z11-5 (SGA) - Body ground	-	Ground for evaporator temperature sensor	Always	Below 1 V

Terminal No. (Symbol)	Wiring Color	Terminal Description	Condition	Specified Condition
z11-6 (TEA) - z11-5 (SGA)	-	A/C evaporator temperature sensor signal	Power switch on (IG) Evaporator temperature: 0°C (32°F)	1.7 to 2.1 V
z11-6 (TEA) - z11-5 (SGA)	-	A/C evaporator temperature sensor signal	Power switch on (IG) Evaporator temperature: 15°C (59°F)	0.9 to 1.3 V

- *1: w/ PTC Heater Assembly
- *2: w/ Solar Ventilation System
- *3: w/ Plasmacluster (Ion Generator)

(a) Waveform 1:

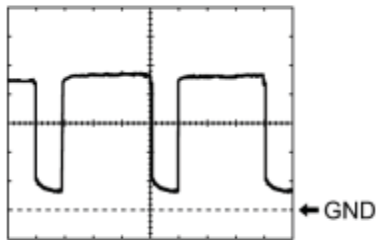

H

Item	Content
Terminal No.	L17-23 (BLW) - L17-14 (GND)
Tool Setting	1 V/DIV., 500 μs/DIV.
Vehicle Condition	Power switch on (IG) Blower switch LO

HINT:

The waveform varies with the blower speed.

(b) Waveform 2:

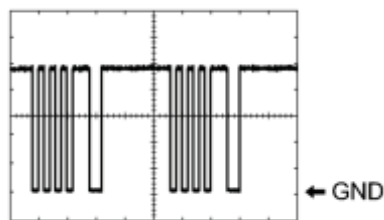

H

Item	Content
Terminal No.	L17-26 (SSLR) - L17-14 (GND)
Tool Setting	1 V/DIV., 100 ms/DIV.
Vehicle Condition	Power switch on (IG) SBI terminal: 7 V or higher Solar ventilation system: off

HINT:

The waveform varies with the communication content.

2. A/C CONTROL ASSEMBLY

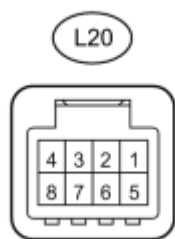

HINT:

Check from the rear of the connector while it is connected to the A/C control assembly.

Terminal No. (Symbol)	Wiring Color	Terminal Description	Condition	Specified Condition
L20-2 (TX+) - L20-8 (GND)	V - W-B	LIN communication signal	Power switch on (IG)	Pulse generation
L20-3 (SWO) - L20-8 (GND)	L - W-B	Steering pad switch assembly signal	No switch pushed → R/F switch pushed → TEMP+ switch pushed → TEMP- switch pushed	4.44 to 5.43 V → 1.19 to 1.49 V → 2.09 to 2.54 V → 3.2 to 3.88 V
L20-5 (IG+) - L20-8 (GND)	B - W-B	Power source (IG)	Power switch off	Below 1 V
L20-5 (IG+) - L20-8 (GND)	B - W-B	Power source (IG)	Power switch on (IG)	11 to 14 V
L20-6 (ILL+) - L20-7 (ILL-)	G - W-B	Light control switch signal	Light control switch off	Below 1 V
L20-6 (ILL+) - L20-7 (ILL-)	G - W-B	Light control switch signal	Light control switch tail or head	11 to 14 V
L20-8 (GND) - Body ground	W-B - Body ground	Ground for front A/C control assembly	Always	Below 1 V

DIAGNOSIS SYSTEM

1. DESCRIPTION

(a) Air conditioning system data and the Diagnostic Trouble Codes (DTCs) can be read through the Data Link Connector 3 (DLC3) of the vehicle. When the system seems to be malfunctioning, use the Techstream to check for malfunctions and perform troubleshooting.

2. CHECK DLC3

(a) Check the DLC3 .

3. LIST OF OPERATION METHODS

(a) By operating each of the air conditioning control switches as shown in the diagram below, it is possible to enter diagnostic check mode.

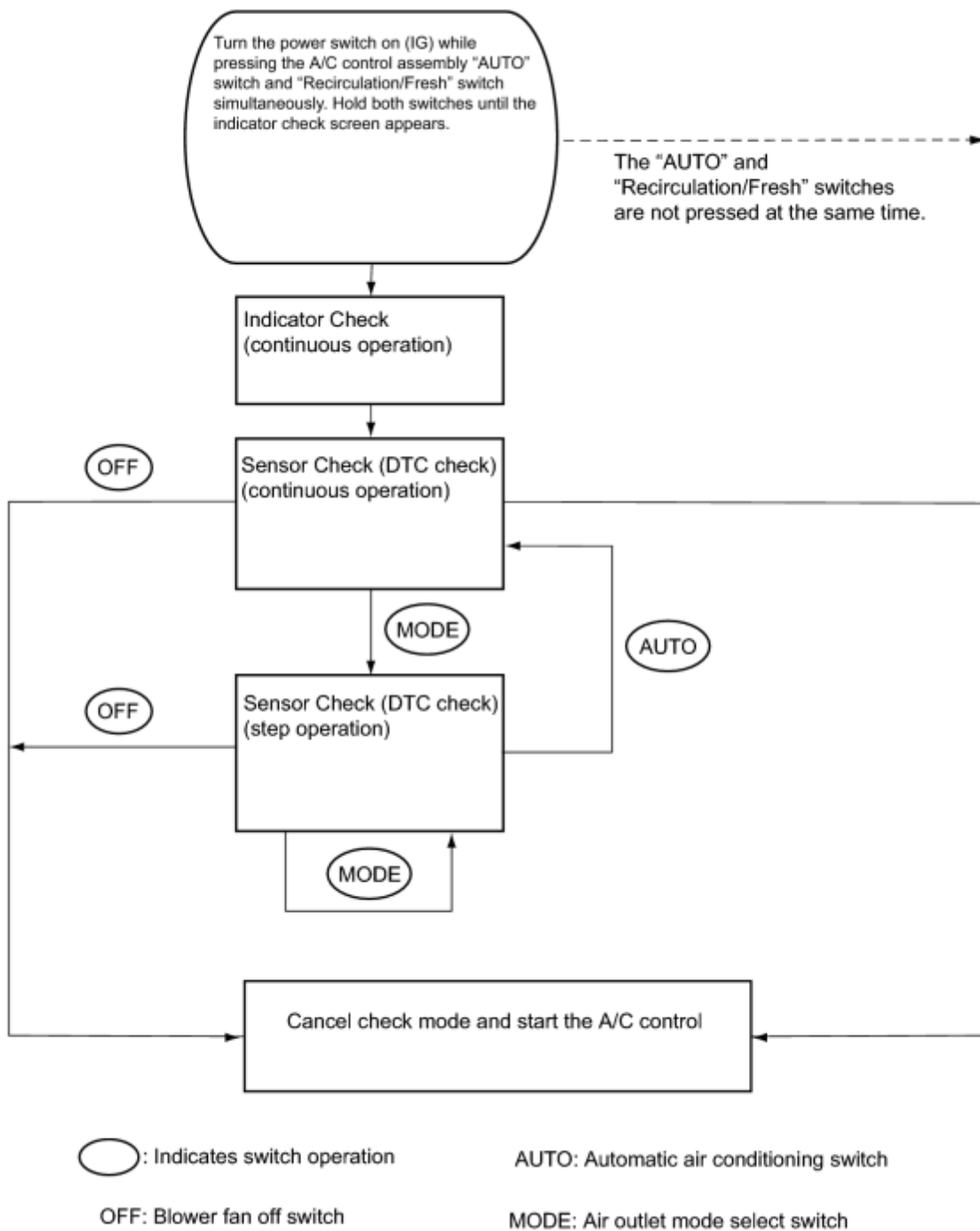

4. INDICATOR CHECK

- (a) Turn the power switch off.
- (b) Turn the power switch on (ACC) and wait for at least 5 seconds.
- (c) Turn the power switch on (IG) while pressing the A/C control

*1

assembly "AUTO" switch and "Recirculation/Fresh" switch simultaneously. Hold both switches until the indicator check screen appears.

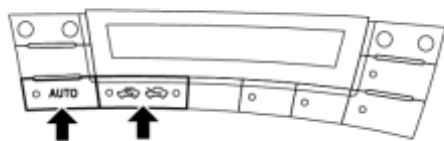

Text in Illustration

*1	A/C Control Assembly
----	----------------------

H

*1

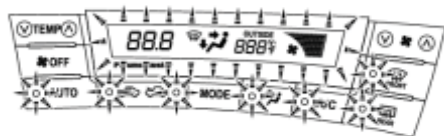

(d) The indicator check is automatically performed when panel diagnosis is activated. Check that the indicators light up and go off 4 times at 1-second intervals continuously.

- The sensor check automatically starts when the indicator check is completed.
- Press the "OFF" switch to cancel the check mode.

Indicator Blinking Pattern:

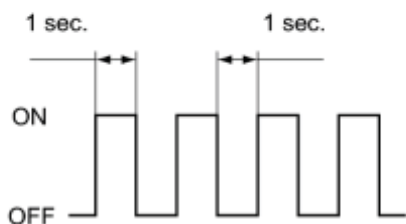

Text in Illustration

*1	A/C Control Assembly
----	----------------------

H

5. SENSOR CHECK (DTC CHECK)

- Start the engine and warm it up.
- Perform the indicator check.

HINT:

After the indicator check is completed, the system enters DTC check mode automatically.

- Read the DTC displayed on the A/C control assembly.

NOTICE:

In sensor check mode, which is automatically entered after indicator check mode, troubleshooting may be partially performed. Be sure to perform the sensor check again.

*1

HINT:

Refer to Diagnostic Trouble Code Chart for details of the codes INFO.

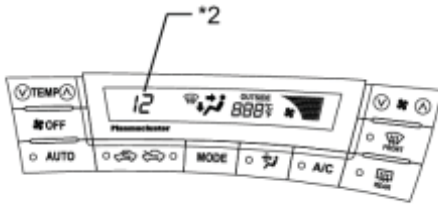

- When there are no problems, DTC 00 is output.
- As an example, the illustration shows that display DTC 12 is output.

Text in Illustration

*1	A/C Control Assembly
*2	Diagnostic Trouble Code (DTC)

H

*1

(d) If the steps are difficult to read because they change automatically, press the "MODE" switch to display the steps one at a time so that they can be read easily. The items are displayed step by step each time the "MODE" switch is pressed.

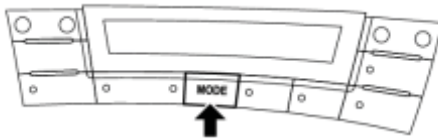

HINT:

Press the "OFF" switch to finish panel diagnosis.

Text in Illustration

*1	A/C Control Assembly
----	----------------------

H

(e) Clear the DTC

*1

(1) During the sensor check, press the "FRONT DEF" switch and "MODE" switch simultaneously.

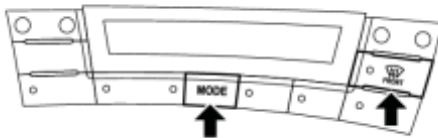

Text in Illustration

*1	A/C Control Assembly
----	----------------------

H

DTC CHECK / CLEAR

1. DTC CHECK USING TECHSTREAM

- (a) Connect the Techstream to the DLC3.
- (b) Turn the power switch on (IG).
- (c) Turn the Techstream on.
- (d) Enter the following menus: Body Electrical / Air Conditioner / Trouble Codes.
- (e) Check for DTCs.

2. DTC CLEAR USING TECHSTREAM

- (a) Connect the Techstream to the DLC3.
- (b) Turn the power switch on (IG).
- (c) Turn the Techstream on.
- (d) Enter the following menus: Body Electrical / Air Conditioner / Trouble Codes.
- (e) Clear the DTCs by pressing the YES button on the Techstream display.

DATA LIST / ACTIVE TEST

1. DATA LIST

Using the Techstream to read the Data List allows the values or states of switches, sensors, actuators and other items to be read without removing any parts. This non-intrusive inspection can be very useful because intermittent conditions or signals may be discovered before parts or wiring is disturbed. Reading the Data List information early in troubleshooting is one way to save diagnostic time.

NOTICE:

In the table below, the values listed under "Normal Condition" are reference values. Do not depend solely on these reference values when deciding whether a part is faulty or not.

- (a) Connect the Techstream to the DLC3.
- (b) Turn the power switch on (IG).
- (c) Turn the Techstream on.
- (d) Enter the following menus: Body Electrical / Air Conditioner / Data List.
- (e) Check the value(s) by referring to the table below.

Air Conditioner

Tester Display	Measurement Item/Range	Normal Condition	Diagnostic Note
Room Temperature Sensor	Room temperature sensor / Min.: -6.5°C (20.3°F) Max.: 57.25°C (135.05°F)	Actual cabin temperature displayed	-
Ambient Temp Sensor	Ambient temperature sensor / Min.: -23.3°C (-9.94°F) Max.: 65.95°C (150.71°F)	Actual ambient temperature displayed	-
Adjusted Ambient Temp	Adjusted ambient temperature / Min.: -30.8°C (-23.44°F) Max.: 50.8°C (123.44°F)	-	-
Evaporator Fin Thermistor	Evaporator temperature sensor / Min.: -29.7°C (-21.46°F) Max.: 59.55°C (139.19°F)	Actual evaporator temperature displayed	-

Tester Display	Measurement Item/Range	Normal Condition	Diagnostic Note
Evaporator Target Temp	Evaporator target temperature / Min.: -327.68°C (-557.82°F) Max.: 327.67°C (621.81°F)	Evaporator target temperature displayed	-
Solar Sensor (D side)	Solar sensor / Min.: 0 Max.: 255	Solar sensor value increases as brightness increases	-
Engine Coolant Temp	Engine coolant temperature sensor / Min.: 1.3°C (34.34°F) Max.: 90.55°C (194.99°F)	Actual engine coolant temperature displayed	-
Set Temperature (D side)	Set temperature / Min.: 65°F (18°C) Max.: 85°F (32°C)	Actual set temperature displayed	-
Blower Motor Speed Level	Blower motor speed level / Min.: 0 Max.: 31	Displayed speed level increases in range between 0 and 31 as blower motor speed increases	-
Regulator Pressure Sensor	Air conditioning pressure sensor / Min.: -0.45668 MPaG Max.: 3.29437 MPaG	Actual regulator pressure displayed	-
Air Mix Servo Targ Pulse (D)	Air mix servo motor target pulse / Min.: 0 Max.: 255	MAX. COLD: 6 (pulse) MAX. HOT: 93 (pulse)	-
Air Mix Servo Actual Pulse (D)	Air mix servo motor actual pulse / Min.: 0 Max.: 255	MAX. COLD: 6 (pulse) MAX. HOT: 93 (pulse)	-
Air Outlet Servo Pulse (D)	Air outlet servo motor target	FACE: 47 (pulse)	-

Tester Display	Measurement Item/Range	Normal Condition	Diagnostic Note
	pulse / Min.: 0 Max.: 255	B/L: 37 (pulse) FOOT: 17(pulse) FOOT/DEF: 9 (pulse) DEF: 5 (pulse)	
Air Outlet Servo Actu Pulse (D)	Air outlet servo motor actual pulse / Min.: 0 Max.: 255	FACE: 47 (pulse) B/L: 37 (pulse) FOOT: 17 (pulse) FOOT/DEF: 9 (pulse) DEF: 5 (pulse)	-
Air Inlet Damper Targ Pulse	Air inlet servo motor target pulse / Min.: 0 Max.: 255	RECIRCULATION: 19 (pulse) FRESH: 7 (pulse)	-
Air Inlet Damper Actual Pulse	Air inlet servo motor actual pulse / Min.: 0 Max.: 255	RECIRCULATION: 19 (pulse) FRESH: 7 (pulse)	-
Compressor Speed	Compressor speed / Min.: 0 rpm Max.: 65535 rpm	Displays actual rotation speed in the range between 0 rpm and 10000 rpm	-
Compressor Target Speed	Compressor target speed / Min.: 0 rpm Max.: 65535 rpm	Displays actual rotation speed in the range between 0 rpm and 10000 rpm	-
Electric Heater Active Level*1	Heater active level / Min.: 0 Max.: 3	Actual electric heater active level displayed	-
ECO Switch	ECO MODE switch / OFF or ON	OFF: ECO MODE switch off ON: ECO MODE switch on	-

Tester Display	Measurement Item/Range	Normal Condition	Diagnostic Note
Solar Ventilation Switch*2	Solar ventilation switch (Switch recognition value at A/C amplifier side) / OFF or ON	OFF: solar ventilation switch off ON: solar ventilation switch on	-
Number of Trouble Codes	Number of trouble codes / Min.: 0 Max.: 255	Number of DTCs displayed	-

- *1: w/ PTC Heater Assembly

- *2: w/ Solar Ventilation System

(f) Connect the Techstream to the DLC3.

(g) Turn the power switch on (IG).

(h) Turn the Techstream on.

(i) Enter the following menus: Body Electrical / Main Body / Data List.

(j) Check the value(s) by referring to the table below.

Main Body

Tester Display	Measurement Item/Range	Normal Condition	Diagnostic Note
Hood Courtesy SW*3	Engine hood courtesy signal / OFF or ON	ON: Engine hood open OFF: Engine hood closed	-

- *3: w/ Remote Air Conditioning System

2. ACTIVE TEST

Using the Techstream to perform Active Tests allows relays, VSVs, actuators and other items to be operated without removing any parts. This non-intrusive functional inspection can be very useful because intermittent operation may be discovered before parts or wiring is disturbed. Performing Active Tests early in troubleshooting is one way to save diagnostic time. Data List information can be displayed while performing Active Tests.

(a) Connect the Techstream to the DLC3.

(b) Turn the power switch on (IG).

(c) Turn the Techstream on.

(d) Enter the following menus: Body Electrical / Air Conditioner / Active Test.

(e) Check the operation by referring to the table below.

Air Conditioner

Tester Display	Test Part	Control Range	Diagnostic Note
Blower Motor	Blower motor	Min.: 0, Max.: 31	-
Compressor Target Speed	Compressor with motor assembly	Min.: 0, Max.: 10000	-
Water Pump	Water pump relay	OFF or ON	-
Electrical Fan	Electrical fan	OFF or ON	-
Heater Active Level*1	Heater active level	Min.: 0, Max.: 3	-
Defogger Relay (Rear)	Defogger relay (Rear)	OFF or ON	-
Mirror Heater Relay (Front)	Mirror heater relay (Front)	OFF or ON	-
Air Mix Servo Targ Pulse (D)	Air mix servo motor pulse	Min.: 0, Max.: 255	-
Air Outlet Servo Pulse (D)	Air outlet servo motor pulse	Min.: 0, Max.: 255	-
Air Inlet Damper Targ Pulse	Air inlet damper target pulse	Min.: 0, Max.: 255	-
Air Purifier Mode*2	Plasmacluster (ion generator)	Stop, Ion, Clean	-





- *1: w/ PTC Heater Assembly
- *2: w/ Plasmacluster (Ion Generator)







DIAGNOSTIC TROUBLE CODE CHART





HINT:

When the air conditioning system functions properly, DTC 00 is output.

Air Conditioning System

DTC Code	Detection Item	Trouble Area	Memory*4	See page
B1411/11*1	Room Temperature Sensor Circuit	<ol style="list-style-type: none"> 1. Room temperature sensor 2. Harness or connector between room temperature sensor and A/C amplifier 3. A/C amplifier 	Memorized (4 sec. or more)	
B1412/12*2	Ambient Temperature Sensor Circuit	<ol style="list-style-type: none"> 1. Ambient temperature sensor 2. Harness or connector between ambient temperature sensor and A/C amplifier 3. A/C amplifier 	Memorized (4 sec. or more)	
B1413/13	Evaporator Temperature Sensor Circuit	<ol style="list-style-type: none"> 1. Evaporator temperature sensor 2. Air conditioning harness 3. A/C amplifier 	Memorized (4 sec. or more)	
B1423/23	Pressure Sensor Circuit	<ol style="list-style-type: none"> 1. A/C pressure sensor 2. Harness or connector between A/C pressure sensor and A/C amplifier 3. A/C amplifier 4. Expansion valve (blocked, stuck) 5. Condenser (blocked, deterioration of cooling capacity due to dirt) 6. Cooler dryer (moisture in the refrigerant cycle cannot be absorbed) 7. Cooling fan system (condenser cannot be cooled down) 8. A/C system (leaks, blocked) 	-	
B1441/41	Air Mix Damper Control Servo Motor Circuit (Passenger Side)	<ol style="list-style-type: none"> 1. Air mix control servo motor 	Memorized (30 sec. or	

DTC Code	Detection Item	Trouble Area	Memory*4	See page
		2. Air conditioning harness 3. A/C amplifier	more)	
B1442/42	Air Inlet Damper Control Servo Motor Circuit	1. Air inlet control servo motor 2. Air conditioning harness 3. A/C amplifier	Memorized (30 sec. or more)	
B1443/43	Air Outlet Damper Control Servo Motor Circuit	1. Air outlet control servo motor 2. Air conditioning harness 3. A/C amplifier	Memorized (30 sec. or more)	
B1471/71	A/C Inverter High Voltage Power Resource System Malfunction	1. Electric vehicle fuse 2. No. 2 engine wire (harness or connector between compressor with motor assembly and inverter with converter assembly) 3. Compressor with motor assembly 4. Hybrid control system 5. CAN communication system	Memorized	
B1472/72	A/C Inverter High Voltage Output System Malfunction	1. Compressor with motor assembly 2. CAN communication system	Memorized	
B1473/73	A/C Inverter Start-up Signal System Malfunction	1. Harness or connector between power management control ECU and compressor with motor assembly 2. Compressor with motor assembly 3. Power management control ECU 4. Hybrid control system 5. CAN communication system	-	
B1474/74	A/C Inverter Malfunction	1. Compressor with motor assembly 2. CAN communication system	Memorized	
B1475/75	A/C Inverter Cooling / Heating System Malfunction	1. Cooling fan system 2. Refrigerant volume	Memorized	

DTC Code	Detection Item	Trouble Area	Memory*4	See page
		3. Compressor with motor assembly 4. CAN communication system		
B1476/76	A/C Inverter Load System Malfunction	1. Refrigerant volume 2. Compressor with motor assembly 3. Cooling fan system 4. CAN communication system	Memorized	
B1477/77	A/C Inverter Low Voltage Power Resource System Malfunction	1. Compressor with motor assembly 2. CAN communication system	Memorized	
B1497/97	BUS IC Communication Malfunction	1. Air conditioning harness 2. A/C amplifier	Memorized (10 sec. or more)	
B1498/98	Communication Malfunction (A/C Inverter Local)	1. Harness or connector between power management control ECU, compressor with motor assembly and body ground 2. Power management control ECU 3. Compressor with motor assembly 4. No. 2 engine wire (harness or connector between compressor with motor assembly and inverter with converter assembly) 5. Electric vehicle fuse 6. CAN communication system 7. Hybrid control system	Memorized	
B14A1*3	Air Purifier Open Circuit	1. Plasmacluster (ion generator) 2. Harness or connector between plasmacluster (ion generator) and A/C amplifier 3. Harness or connector between plasmacluster (ion generator) and battery 4. Harness or connector between plasmacluster (ion generator) and body ground	Memorized (4 sec. or more)	

DTC Code	Detection Item	Trouble Area	Memory*4	See page
		5. A/C amplifier		
B14A2	Driver Side Solar Sensor Short Circuit	1. Solar sensor (automatic light control sensor) 2. Harness or connector between solar sensor (automatic light control sensor) and A/C amplifier 3. Harness or connector between solar sensor (automatic light control sensor) and main body ECU 4. Main body ECU 5. A/C amplifier	Memorized (4 sec. or more)	INFO
U0100	Lost Communication with ECM	1. CAN communication system 2. ECM	-	INFO
U0101	Lost Communication with TCM	1. CAN communication system 2. TCM	-	INFO
U0131	Lost Communication with Electric Power Steering ECU	1. CAN communication system 2. Electric power steering ECU	-	INFO
U0142	Lost Communication with Main Body ECU	1. CAN communication system 2. Main body ECU	-	INFO
U0155	Lost Communication with Combination Meter	1. CAN communication system 2. Combination meter	-	INFO
U0293	Lost Communication with HV ECU	1. CAN communication system 2. Power management control ECU	-	INFO

Hybrid Control System

DTC Code	Detection Item	Trouble Area	Memory	See page
P0AA6-611	Hybrid Battery Voltage System Isolation Fault	1. Compressor oil 2. Refrigerant pipe line 3. Compressor with motor assembly 4. CAN communication system	-	INFO

- *1: If the cabin temperature is approximately -18.6°C (-1.48°F) or lower, DTC B1411/11 may be output even though the system is normal.
- *2: If the ambient temperature is approximately -52.9°C (-63.22°F) or lower, DTC B1412/12 may be output even though the system is normal.
- *3: w/ Plasmacluster (Ion Generator)
- *4: The A/C amplifier stores the DTC of the respective malfunction if it has occurred for the period of time indicated in the brackets.

DESCRIPTION

The room temperature sensor is installed in the instrument panel. It detects the cabin temperature to control the air conditioning AUTO mode. The resistance of the room temperature sensor changes in accordance with the cabin temperature. As the temperature decreases, the resistance increases. As the temperature increases, the resistance decreases.

The A/C amplifier applies voltage (5 V) to the room temperature sensor and reads voltage changes as the resistance of the room temperature sensor changes. This sensor also sends appropriate signals to the A/C amplifier. The room temperature sensor is integrated with the room humidity sensor.

DTC No.	DTC Detection Condition	Trouble Area
B1411/11	Open or short in room temperature sensor circuit	<ul style="list-style-type: none"> Room temperature sensor Harness or connector between room temperature sensor and A/C amplifier A/C amplifier

WIRING DIAGRAM

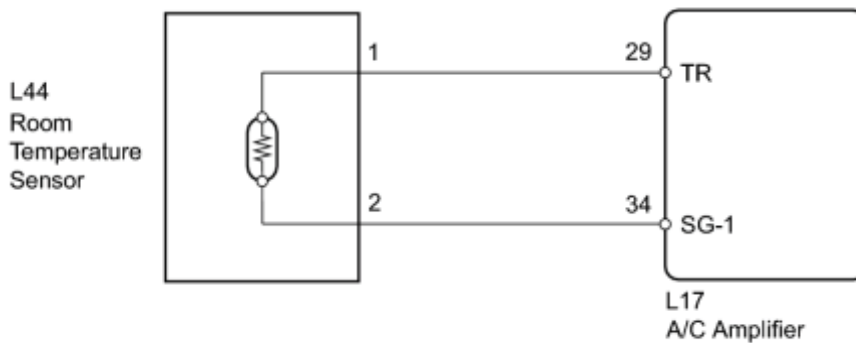

INSPECTION PROCEDURE

PROCEDURE

1. READ VALUE USING TECHSTREAM

- (a) Connect the Techstream to the DLC3.
- (b) Turn the power switch on (IG).

(c) Turn the Techstream on.

(d) Enter the following menus: Body Electrical / Air Conditioner / Data List.

(e) Check the value(s) by referring to the table below.

Air Conditioner

Tester Display	Measurement Item/Range	Normal Condition	Diagnostic Note
Room Temperature Sensor	Room temperature sensor / Min.: -6.5°C (20.3°F) Max.: 57.25°C (135.05°F)	Actual cabin temperature displayed	-

OK:

The display is as specified in the Normal Condition column.

Result:

Result	Proceed to
NG	A
OK (When troubleshooting according to Problem Symptoms Table)	B
OK (When troubleshooting according to the DTC)	C

C ▶ REPLACE A/C AMPLIFIER

B ▶ PROCEED TO NEXT SUSPECTED AREA SHOWN IN PROBLEM SYMPTOMS TABLE

A



2.	INSPECT ROOM TEMPERATURE SENSOR
----	---------------------------------

(a) Remove the room temperature sensor.

(b) Disconnect the room temperature sensor connector.

*1

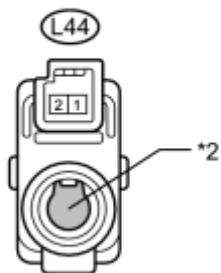

Resistance (kΩ)

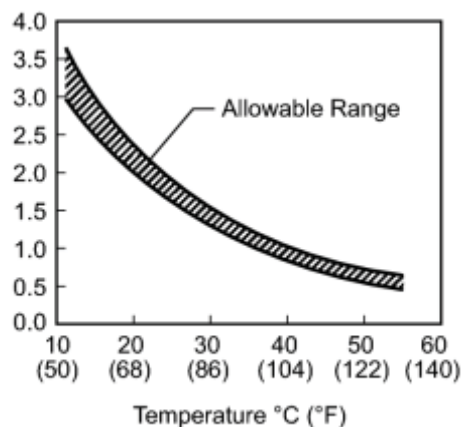

(c) Measure the resistance according to the value(s) in the table below.

Standard Resistance:

Tester Connection	Condition	Specified Condition
L44-1 - L44-2	10°C (50°F)	3.00 to 3.73 kΩ
L44-1 - L44-2	15°C (59°F)	2.45 to 2.88 kΩ
L44-1 - L44-2	20°C (68°F)	1.95 to 2.30 kΩ
L44-1 - L44-2	25°C (77°F)	1.60 to 1.80 kΩ
L44-1 - L44-2	30°C (86°F)	1.28 to 1.47 kΩ
L44-1 - L44-2	35°C (95°F)	1.00 to 1.22 kΩ
L44-1 - L44-2	40°C (104°F)	0.80 to 1.00 kΩ
L44-1 - L44-2	45°C (113°F)	0.65 to 0.85 kΩ
L44-1 - L44-2	50°C (122°F)	0.50 to 0.70 kΩ
L44-1 - L44-2	55°C (131°F)	0.44 to 0.60 kΩ
L44-1 - L44-2	60°C (140°F)	0.36 to 0.50 kΩ

NOTICE:

- Hold the sensor only by its connector. Touching the sensor may change the resistance value.
- When measuring, the sensor temperature must be the same as the ambient temperature.

HINT:

As the temperature increases, the resistance decreases (see the graph).

Text in Illustration

*1	Component without harness connected (Room Temperature Sensor)
*2	Sensing Portion

NG ▶ REPLACE ROOM TEMPERATURE SENSOR

OK



3.	CHECK HARNESS AND CONNECTOR (ROOM TEMPERATURE SENSOR - A/C AMPLIFIER)
----	---

*1

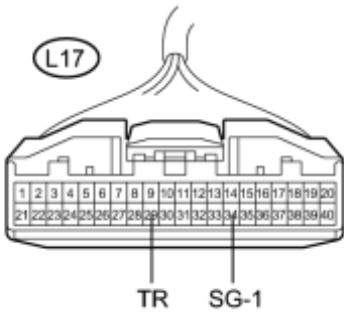

H

(a) Disconnect the A/C amplifier connector.

*2

(b) Measure the resistance according to the value(s) in the table below.

Standard Resistance:

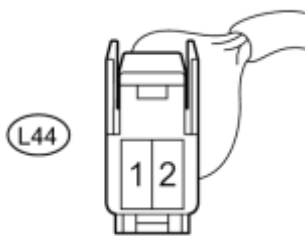

H

Tester Connection	Condition	Specified Condition
L17-29 (TR) - L44-1	Always	Below 1 Ω
L17-34 (SG-1) - L44-2	Always	Below 1 Ω
L17-29 (TR) - Body ground	Always	10 kΩ or higher
L17-34 (SG-1) - Body ground	Always	10 kΩ or higher

Text in Illustration

*1	Front view of wire harness connector (to A/C Amplifier)
*2	Front view of wire harness connector (to Room Temperature Sensor)

NG ► REPAIR OR REPLACE HARNESS OR CONNECTOR

OK ► REPLACE A/C AMPLIFIER

DESCRIPTION

The ambient temperature sensor is installed in front of the condenser. It detects the ambient temperature to control air conditioning AUTO mode. This sensor is connected to the A/C amplifier and detects fluctuations in the ambient temperature. This data is used for controlling the cabin temperature. The sensor sends a signal to the A/C amplifier. The resistance of the ambient temperature sensor changes in accordance with the ambient temperature. As the temperature decreases, the resistance increases. As the temperature increases, the resistance decreases.

The A/C amplifier applies voltage (5 V) to the ambient temperature sensor and reads voltage changes as the resistance of the ambient temperature sensor changes.

DTC No.	DTC Detection Condition	Trouble Area
B1412/12	Open or short in ambient temperature sensor circuit	<ul style="list-style-type: none"> • Ambient temperature sensor • Harness or connector between ambient temperature sensor and A/C amplifier • A/C amplifier

WIRING DIAGRAM

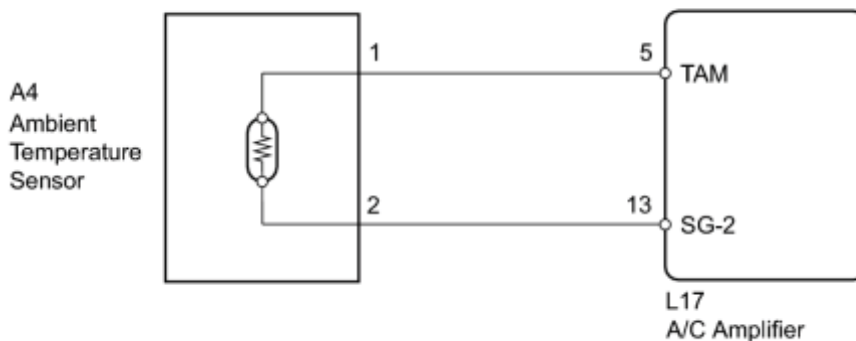

INSPECTION PROCEDURE

PROCEDURE

1.	READ VALUE USING TECHSTREAM
----	-----------------------------

(a) Connect the Techstream to the DLC3.

- (b) Turn the power switch on (IG).
- (c) Turn the Techstream on.
- (d) Enter the following menus: Body Electrical / Air Conditioner / Data List.
- (e) Check the value(s) by referring to the table below.

Air Conditioner

Tester Display	Measurement Item/Range	Normal Condition	Diagnostic Note
Ambient Temp Sensor	Ambient temperature sensor / Min: -23.3°C (-9.94°F) Max: 65.95°C (150.71°F)	Actual ambient temperature displayed	-

OK:

The display is as specified in the Normal Condition column.

Result:

Result	Proceed to
NG	A
OK (When troubleshooting according to Problem Symptoms Table)	B
OK (When troubleshooting according to the DTC)	C

C ▶ REPLACE A/C AMPLIFIER

B ▶ PROCEED TO NEXT SUSPECTED AREA SHOWN IN PROBLEM SYMPTOMS TABLE

A



2.	INSPECT AMBIENT TEMPERATURE SENSOR
----	------------------------------------

(a) Remove the ambient temperature sensor.

(b) Disconnect the ambient temperature sensor connector.

*1

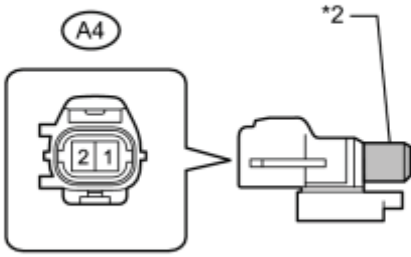

Resistance (kΩ)

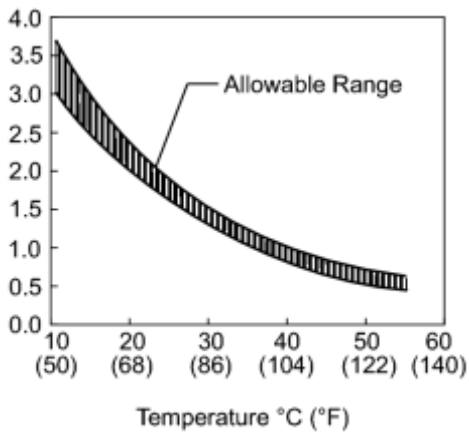

(c) Measure the resistance according to the value(s) in the table below.

Standard Resistance:

Tester Connection	Condition	Specified Condition
A4-1 - A4-2	10°C (50°F)	3.00 to 3.73 kΩ
A4-1 - A4-2	15°C (59°F)	2.45 to 2.88 kΩ
A4-1 - A4-2	20°C (68°F)	1.95 to 2.30 kΩ
A4-1 - A4-2	25°C (77°F)	1.60 to 1.80 kΩ
A4-1 - A4-2	30°C (86°F)	1.28 to 1.47 kΩ
A4-1 - A4-2	35°C (95°F)	1.00 to 1.22 kΩ
A4-1 - A4-2	40°C (104°F)	0.80 to 1.00 kΩ
A4-1 - A4-2	45°C (113°F)	0.65 to 0.85 kΩ
A4-1 - A4-2	50°C (122°F)	0.50 to 0.70 kΩ
A4-1 - A4-2	55°C (131°F)	0.44 to 0.60 kΩ
A4-1 - A4-2	60°C (140°F)	0.36 to 0.50 kΩ

NOTICE:

- Hold the sensor only by its connector. Touching the sensor may change the resistance value.
- When measuring, the sensor temperature must be the same as the ambient temperature.

HINT:

As the temperature increases, the resistance decreases (see the graph).

Text in Illustration

*1	Component without harness connected (Ambient Temperature Sensor)
*2	Sensing Portion

NG REPLACE AMBIENT TEMPERATURE SENSOR

OK



3.	CHECK HARNESS AND CONNECTOR (AMBIENT TEMPERATURE SENSOR - A/C AMPLIFIER)
----	--

*1

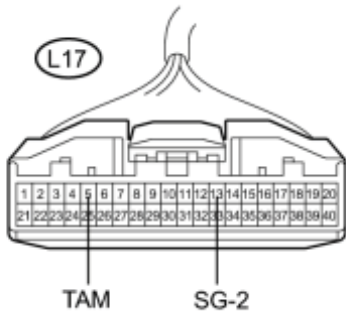

(a) Disconnect the A/C amplifier connector.

H

(b) Measure the resistance according to the value(s) in the table below.

*2

Standard Resistance:



Tester Connection	Condition	Specified Condition
L17-5 (TAM) - A4-1	Always	Below 1 Ω
L17-13 (SG-2) - A4-2	Always	Below 1 Ω
L17-5 (TAM) - Body ground	Always	10 kΩ or higher
L17-13 (SG-2) - Body ground	Always	10 kΩ or higher

Text in Illustration

*1	Front view of wire harness connector (to A/C Amplifier)
*2	Front view of wire harness connector (to Ambient Temperature Sensor)

NG ► REPAIR OR REPLACE HARNESS OR CONNECTOR

OK ► REPLACE A/C AMPLIFIER

DESCRIPTION

The evaporator temperature sensor is installed on the evaporator in the air conditioning unit to detect the cooled air temperature that has passed through the evaporator and to control the air conditioning. It sends appropriate signals to the A/C amplifier. The resistance of the evaporator temperature sensor changes in accordance with the cooled air temperature that has passed through the evaporator. As the temperature decreases, the resistance increases. As the temperature increases, the resistance decreases.

The A/C amplifier applies voltage (5 V) to the evaporator temperature sensor and reads voltage changes as the resistance of the evaporator temperature sensor changes. This sensor is used for frost prevention.

DTC No.	DTC Detection Condition	Trouble Area
B1413/13	Open or short in evaporator temperature sensor circuit	<ul style="list-style-type: none"> Evaporator temperature sensor Air conditioning harness A/C amplifier

WIRING DIAGRAM

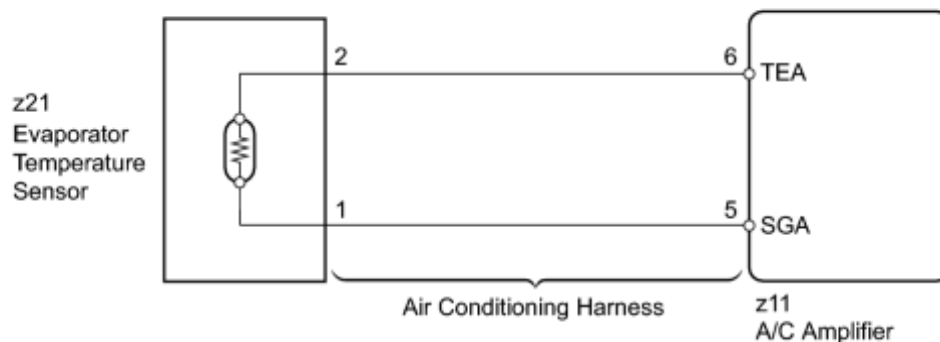

INSPECTION PROCEDURE

PROCEDURE

1.	READ VALUE USING TECHSTREAM
----	-----------------------------

(a) Connect the Techstream to the DLC3.

(b) Turn the power switch on (IG).

(c) Turn the Techstream on.

(d) Enter the following menus: Body Electrical / Air Conditioner / Data List.

(e) Check the value(s) by referring to the table below.

Air Conditioner

Tester Display	Measurement Item/Range	Normal Condition	Diagnostic Note
Evaporator Fin Thermistor	Evaporator temperature sensor / Min.: -29.7°C (-21.46°F) Max.: 59.55°C (139.19°F)	Actual evaporator temperature displayed	-

OK:

The display is as specified in the Normal Condition column.

Result:

Result	Proceed to
NG	A
OK (When troubleshooting according to Problem Symptoms Table)	B
OK (When troubleshooting according to the DTC)	C

C ▶ REPLACE A/C AMPLIFIER

B ▶ PROCEED TO NEXT SUSPECTED AREA SHOWN IN PROBLEM SYMPTOMS TABLE

A



2.	INSPECT EVAPORATOR TEMPERATURE SENSOR
----	---------------------------------------

(a) Remove the evaporator temperature sensor.

(b) Disconnect the evaporator temperature sensor connector.

*1

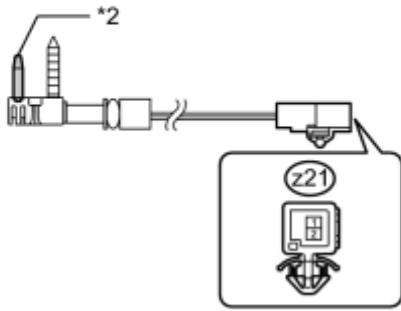

Resistance (kΩ)

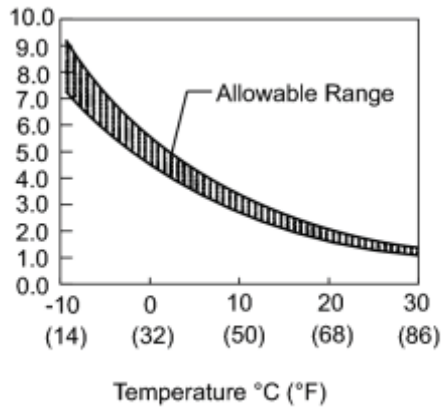

H

(c) Measure the resistance according to the value(s) in the table below.

Standard Resistance:

Tester Connection	Condition	Specified Condition
z21-1 - z21-2	-10°C (14°F)	7.30 to 9.10 kΩ
z21-1 - z21-2	-5°C (23°F)	5.65 to 6.95 kΩ
z21-1 - z21-2	0°C (32°F)	4.40 to 5.35 kΩ
z21-1 - z21-2	5°C (41°F)	3.40 to 4.15 kΩ
z21-1 - z21-2	10°C (50°F)	2.70 to 3.25 kΩ
z21-1 - z21-2	15°C (59°F)	2.14 to 2.58 kΩ
z21-1 - z21-2	20°C (68°F)	1.71 to 2.05 kΩ
z21-1 - z21-2	25°C (77°F)	1.38 to 1.64 kΩ
z21-1 - z21-2	30°C (86°F)	1.11 to 1.32 kΩ

NOTICE:

- Hold the sensor only by its connector. Touching the sensor may change the resistance value.
- When measuring, the sensor temperature must be the same as the ambient temperature.

HINT:

As the temperature increases, the resistance decreases (see the graph).

Text in Illustration

*1	Component without harness connected (Evaporator Temperature Sensor)
*2	Sensing Portion

NG REPLACE EVAPORATOR TEMPERATURE SENSOR

OK



3.	INSPECT AIR CONDITIONING HARNESS (A/C AMPLIFIER - EVAPORATOR TEMPERATURE SENSOR)
----	--

*1

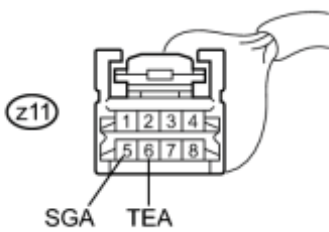

(a) Remove the air conditioning harness.

(b) Measure the resistance according to the value(s) in the table below.

Standard Resistance:

*2

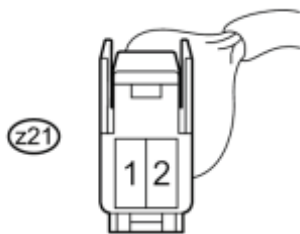

Tester Connection	Condition	Specified Condition
z11-6 (TEA) - z21-2	Always	Below 1 Ω
z11-5 (SGA) - z21-1	Always	Below 1 Ω
z11-6 (TEA) - Body ground	Always	10 kΩ or higher
z11-5 (SGA) - Body ground	Always	10 kΩ or higher

Text in Illustration

H

*1	Front view of wire harness connector (to A/C Amplifier)
----	--

*2

Front view of wire harness connector
(to Evaporator Temperature Sensor)

NG  REPLACE AIR CONDITIONING HARNESS

OK  REPLACE A/C AMPLIFIER

DESCRIPTION

This DTC is stored when refrigerant pressure on the high pressure side is extremely low (0.19 MPa (2.0 kgf/cm², 28 psi) or less) or extremely high (3.14 MPa (32.0 kgf/cm², 455 psi) or more). The A/C pressure sensor is installed on the high pressure line. It detects refrigerant pressure to output a refrigerant pressure signal to the A/C amplifier. The A/C amplifier converts this signal to a pressure value according to the sensor characteristics to control the compressor.

DTC No.	DTC Detection Condition	Trouble Area
B1423/23	<ul style="list-style-type: none"> • Open or short in pressure sensor circuit • Refrigerant pressure on the high pressure line is extremely low (0.19 MPa (2.0 kgf/cm², 28 psi) or less) or extremely high (3.14 MPa (32.0 kgf/cm², 455 psi) or more). 	<ul style="list-style-type: none"> • A/C pressure sensor • Harness or connector between A/C pressure sensor and A/C amplifier • A/C amplifier • Expansion valve (blocked, stuck) • Condenser (blocked, deterioration of cooling capacity due to dirt) • Cooler dryer (moisture in the refrigerant cycle cannot be absorbed) • Cooling fan system (condenser cannot be cooled down) • A/C system (leaks, blocked)

WIRING DIAGRAM

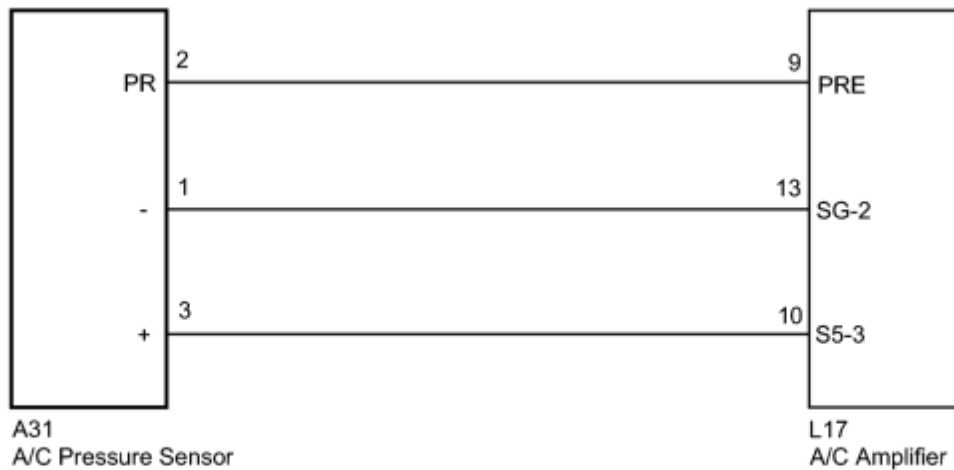

INSPECTION PROCEDURE

PROCEDURE

- CHECK HARNESS AND CONNECTOR (POWER SOURCE CIRCUIT)

*1

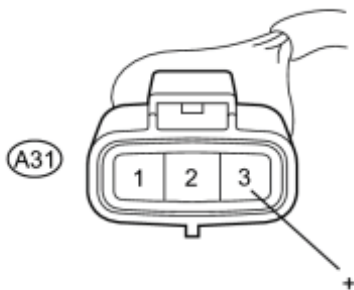

- Disconnect the A/C pressure sensor connector.

H

- Measure the voltage according to the value(s) in the table below.

Standard Voltage:

Tester Connection	Switch Condition	Specified Condition
A31-3 (+) - Body ground	Power switch on (IG)	4.75 to 5.25 V

Text in Illustration

*1	Front view of wire harness connector (to A/C Pressure Sensor)
----	--

NG ► [CHECK HARNESS AND CONNECTOR \(A/C AMPLIFIER - A/C PRESSURE SENSOR\)](#)

OK



2.	CHECK HARNESS AND CONNECTOR (GROUND CIRCUIT)
----	--

*1

(a) Measure the resistance according to the value(s) in the table below.

Standard Resistance:

Tester Connection	Condition	Specified Condition
A31-1 (-) - Body ground	Always	Below 1 Ω

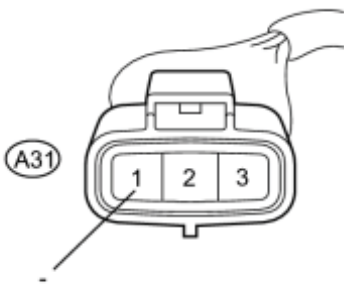

Text in Illustration

H

*1	Front view of wire harness connector (to A/C Pressure Sensor)
----	--

NG ► [CHECK HARNESS AND CONNECTOR \(A/C AMPLIFIER - A/C PRESSURE SENSOR\)](#)

OK



3.	INSPECT A/C PRESSURE SENSOR (SENSOR SIGNAL CIRCUIT)
----	---

(a) Reconnect the A/C pressure sensor connector.

(b) Remove the A/C amplifier with the connectors still connected.

*1

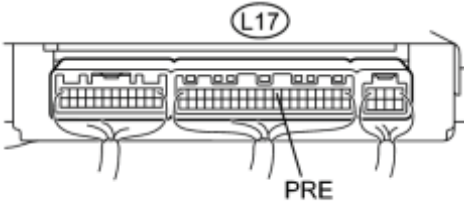

H

(c) Measure the voltage according to the value(s) in the table below.

Standard Voltage:

Tester Connection	Condition	Specified Condition
L17-9 (PRE) - Body ground	Power switch on (IG) (A/C: off)	0.73 to 4.84 V

HINT:

If the voltage is not as specified, there may be a malfunction in the A/C amplifier, A/C pressure sensor or wire harness. It is also possible that the amount of refrigerant may not be appropriate.

Text in Illustration

*1	Component with harness connected (A/C Amplifier)
----	---

NG [CHECK HARNESS AND CONNECTOR \(A/C AMPLIFIER - A/C PRESSURE SENSOR\)](#)

OK



4.	INSPECT A/C PRESSURE SENSOR (SENSOR SIGNAL CIRCUIT)
----	---

(a) Measure the voltage when the following conditions are satisfied.

Item	Condition
Vehicle Doors	Fully open
Temperature Setting	MAX COLD
Blower Speed	HI
A/C Switch	on

Item	Condition
R/F Switch	RECIRCULATION
Interior Temperature	25 to 35°C (77 to 95°F)

NOTICE:

- If refrigerant pressure on the high pressure line becomes extremely high during the inspection (if the voltage exceeds 4.84 V), the fail-safe function stops compressor operation. Therefore, measure the voltage before the fail-safe function operates.
- It is necessary to measure the voltage over a period of time (approximately 10 minutes) because the problem symptom may recur after a while.

HINT:

When the outside air temperature is low (below -1.5°C (29.3°F)), the compressor stops due to signals from the ambient temperature sensor and evaporator temperature sensor to prevent the evaporator from freezing. In this case, perform the inspection in a warm indoor environment.

(1) Measure the voltage according to the value(s) in the table below.

Standard Voltage:

Tester Connection	Condition	Specified Condition
L17-9 (PRE) - Body ground	Power switch on (IG) (A/C: on)	0.73 to 4.84 V

*1

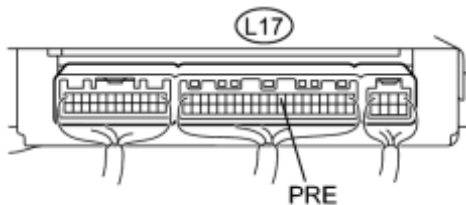

Result:

Result	Proceed to
OK (When troubleshooting according to the DTC)	A
OK (When troubleshooting according to Problem Symptoms Table)	B
NG	C

H

Text in Illustration

*1	Component with harness connected (A/C Amplifier)
----	---

C [INSPECT COOLING FAN SYSTEM](#)

B [PROCEED TO NEXT SUSPECTED AREA SHOWN IN PROBLEM SYMPTOMS TABLE](#)

A [REPLACE A/C AMPLIFIER](#)

5. CHECK HARNESS AND CONNECTOR (A/C AMPLIFIER - A/C PRESSURE SENSOR)

*1

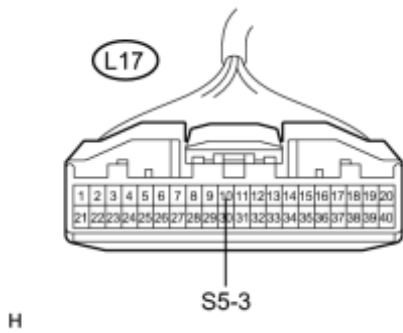

(a) Disconnect the A/C amplifier connector.

(b) Measure the resistance according to the value(s) in the table below.

Standard Resistance:

*2

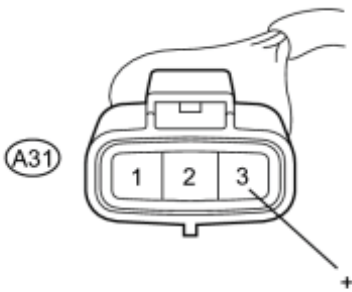

Tester Connection	Condition	Specified Condition
A31-3 (+) - L17-10 (S5-3)	Always	Below 1 Ω
L17-10 (S5-3) - Body ground	Always	10 k Ω or higher

Text in Illustration

*1	Front view of wire harness connector (to A/C Amplifier)
*2	Front view of wire harness connector (to A/C Pressure Sensor)

NG REPAIR OR REPLACE HARNESS OR CONNECTOR

OK REPLACE A/C AMPLIFIER

6. CHECK HARNESS AND CONNECTOR (A/C AMPLIFIER - A/C PRESSURE SENSOR)

(a) Disconnect the A/C amplifier connector.

*1

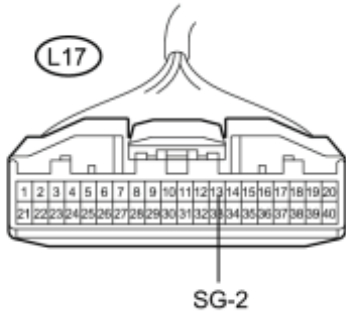

H

(b) Measure the resistance according to the value(s) in the table below.

Standard Resistance:

*2

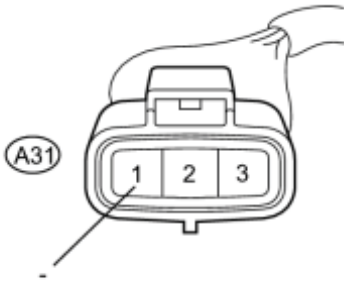

H

Tester Connection	Condition	Specified Condition
A31-1 (-) - L17-13 (SG-2)	Always	Below 1 Ω
L17-13 (SG-2) - Body ground	Always	10 k Ω or higher

Text in Illustration

*1	Front view of wire harness connector (to A/C Amplifier)
*2	Front view of wire harness connector (to A/C Pressure Sensor)

NG ► REPAIR OR REPLACE HARNESS OR CONNECTOR

OK ► REPLACE A/C AMPLIFIER

7.	CHECK HARNESS AND CONNECTOR (A/C AMPLIFIER - A/C PRESSURE SENSOR)
----	---

(a) Disconnect the A/C amplifier connector.

*1

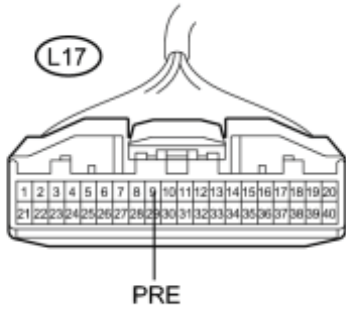

H

(b) Measure the resistance according to the value(s) in the table below.

Standard Resistance:

*2

Tester Connection	Condition	Specified Condition
A31-2 (PR) - L17-9 (PRE)	Always	Below 1 Ω
L17-9 (PRE) - Body ground	Always	10 kΩ or higher

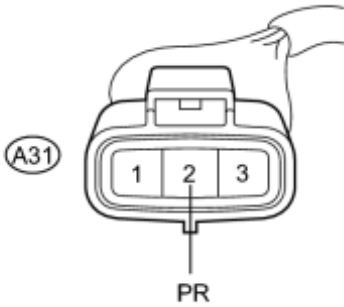

H

Text in Illustration

*1	Front view of wire harness connector (to A/C Amplifier)
*2	Front view of wire harness connector (to A/C Pressure Sensor)

NG REPAIR OR REPLACE HARNESS OR CONNECTOR

OK

8. CHECK FOR A/C SYSTEM LEAK

- Install the manifold gauge set.
- Recover the refrigerant from the A/C system using a refrigerant recovery unit.
- Evacuate the A/C system and check that vacuum can be maintained.

OK:

Vacuum can be maintained in the A/C system.

HINT:

If vacuum cannot be maintained in the A/C system, there may be a refrigerant leak. In this case, it is necessary to repair or replace the leaking part of the A/C system.

NG  [REPAIR A/C SYSTEM LEAK](#)

OK



9. CHARGE REFRIGERANT

(a) Add an appropriate amount of refrigerant .

NEXT



10. RECHECK FOR DTC

(a) Recheck for the DTC when the following conditions are satisfied.

Item	Condition
Vehicle Doors	Fully open
Temperature Setting	MAX COLD
Blower Speed	HI
A/C Switch	on
R/F Switch	RECIRCULATION
Interior Temperature	25 to 35°C (77 to 95°F)

NOTICE:

If refrigerant pressure on the high pressure line is excessive, this DTC will be set. Therefore, it is necessary to measure the voltage over a period of time (approximately 10 minutes) because this DTC may be set after the A/C has been operating for a while.

HINT:

When the outside air temperature is low (below -1.5°C (29.3°F)), the compressor stops due to signals from the ambient temperature sensor and the evaporator temperature sensor to prevent the evaporator from freezing. In this case, perform the inspection in a warm indoor environment.

Result:

Result	Proceed to
DTC B1423/23 is output	A

Result	Proceed to
DTC B1423/23 is not output	B

NOTICE:

If the DTC was set due to an insufficient or excessive amount of refrigerant, the problem may have been solved after performing the previous step. However, the root cause of insufficient refrigerant may be refrigerant leaks. The root cause of excessive refrigerant may be adding refrigerant when the level was insufficient. Therefore, identify and repair any refrigerant leaks as necessary.

B▶ END

A



11.	INSPECT A/C PRESSURE SENSOR
-----	-----------------------------

- (a) Install the manifold gauge set.
- (b) Reconnect the A/C pressure sensor connector.
- (c) Turn the power switch on (IG).

*1

(d) Measure the voltage according to the value(s) in the table below.

Standard Voltage:

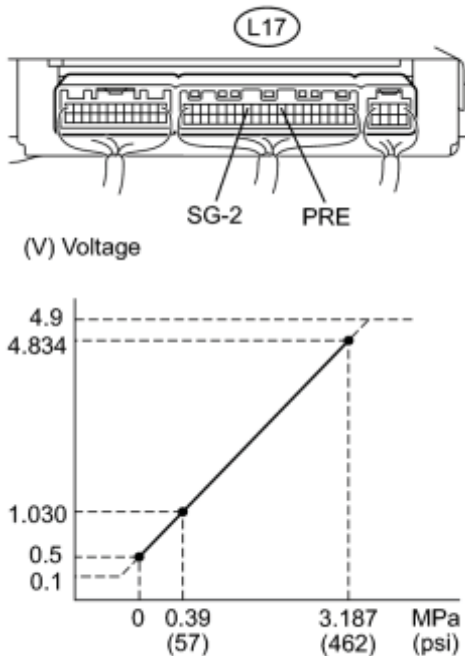

Tester Connection	Condition	Specified Condition
L17-9 (PRE) - L17-13 (SG-2)	Refrigerant pressure: Normal pressure (less than 3.187 MPa [462 psi] and more than 0.39 MPa [57 psi])	1.0 to 4.912 V

Text in Illustration

*1	Component with harness connected (A/C Amplifier)
----	---

NG▶ [REPLACE A/C PRESSURE SENSOR](#)

OK  **REPLACE A/C AMPLIFIER**

12. REPAIR A/C SYSTEM LEAK

- (a) Identify the area where refrigerant leaks from .
- (b) Repair the identified area of the A/C system.
- (c) Evacuate the A/C system.

NEXT  **CHARGE REFRIGERANT**

13. INSPECT COOLING FAN SYSTEM

- (a) Check that the cooling fan(s) operates normally.

HINT:

Refer to Cooling Fan Circuit .

NG  **REPAIR COOLING FAN SYSTEM**

OK



14. CHARGE REFRIGERANT

- (a) Use a refrigerant recovery unit to recover refrigerant.
- (b) Evacuate the A/C system.
- (c) Add an appropriate amount of refrigerant .

HINT:

If refrigerant is added and the system has not been properly evacuated (insufficient vacuum time), moisture in the air remaining in the system will freeze in the expansion valve, blocking the flow on the high pressure side. Therefore, recover the refrigerant and properly evacuate the system. Add an appropriate amount of refrigerant, and check for DTCs.

NEXT



15. RECHECK FOR DTC

- (a) Recheck for the DTC when the following conditions are satisfied.

Item	Condition
Vehicle Doors	Fully open
Temperature Setting	MAX COLD
Blower Speed	HI
A/C Switch	on
R/F Switch	RECIRCULATION
Interior Temperature	25 to 35°C (77 to 95°F)

NOTICE:

If refrigerant pressure on the high pressure line is excessive, this DTC will be set. Therefore, it is necessary to measure the voltage over a period of time (approximately 10 minutes) because DTC may be set after the A/C has been operating for a while.

HINT:

- When the outside air temperature is low (below -1.5°C (29.3°F)), the compressor stops due to signals from the ambient temperature sensor and the evaporator temperature sensor to prevent the evaporator from freezing. In this case, perform the inspection in a warm indoor environment.
- If refrigerant is added and the system has not been properly evacuated (insufficient vacuum time), moisture in the air remaining in the system will freeze in the expansion valve, blocking the flow on the high pressure side. Therefore, recover the refrigerant and properly evacuate the system. Add an appropriate amount of refrigerant, and check for the DTC. If the DTC is not output, it indicates that the cooler dryer in the condenser is not able to absorb moisture in the refrigerant. In this case, to complete the repair, it is necessary to replace the cooler dryer.

Result:

Result	Proceed to
DTC B1423/23 is output	A
DTC B1423/23 is not output	B

B ▶ REPLACE COOLER DRYER

A



16.	REPLACE EXPANSION VALVE
-----	-------------------------

(a) Replace the expansion valve with a new or a known good one .

HINT:

Replace the expansion valve with a new or a known good one because the expansion valve is either stuck or clogged.

NEXT



17. CHARGE REFRIGERANT

(a) Add an appropriate amount of refrigerant .

NEXT



18. RECHECK FOR DTC

(a) Recheck for the DTC when the following conditions are satisfied.

Item	Condition
Vehicle Doors	Fully open
Temperature Setting	MAX COLD
Blower Speed	HI
A/C Switch	on
R/F Switch	RECIRCULATION
Interior Temperature	25 to 35°C (77 to 95°F)

NOTICE:

If refrigerant pressure on the high pressure line is excessive, this DTC will be set. Therefore, it is necessary to measure the voltage over a period of time (approximately 10 minutes) because this DTC may be set after the A/C has been operating for a while.

HINT:

- When the outside air temperature is low (below -1.5°C (29.3°F)), the compressor stops due to signals from the ambient temperature sensor and evaporator temperature sensor to prevent the evaporator from freezing. In this case, perform the inspection in a warm indoor environment.
- If refrigerant pressure is not normal after replacing the expansion valve with a new or a known good one, the condenser or pipes may be clogged with dirt, dust or other contaminants. In this case, clean or replace the condenser or pipes.

Result:

Result	Proceed to
DTC B1423/23 is not output	A
DTC B1423/23 is output	B

 REPLACE CONDENSER

A END

19. REPLACE A/C PRESSURE SENSOR

(a) Replace the A/C pressure sensor **NFC**.

HINT:

Since the A/C pressure sensor cannot be inspected while it is removed from the vehicle, replace the A/C pressure sensor with a new or a known good one and check that the condition returns to normal.

NEXT



20. RECHECK FOR DTC

(a) Recheck for the DTC when the following conditions are satisfied.

Item	Condition
Vehicle Doors	Fully open
Temperature Setting	MAX COLD
Blower Speed	HI
A/C Switch	on
R/F Switch	RECIRCULATION
Interior Temperature	25 to 35°C (77 to 95°F)

NOTICE:

If refrigerant pressure on the high pressure line is excessive, this DTC will be set. Therefore, it is necessary to measure the voltage over a period of time (approximately 10 minutes) because this DTC may be set after the A/C has been operating for a while.

HINT:

When the outside air temperature is low (below -1.5°C (29.3°F)), the compressor stops due to signals from the ambient temperature sensor and evaporator temperature sensor to prevent the evaporator from freezing. In this case, perform the inspection in a warm indoor environment.

Result:

Result	Proceed to
DTC B1423/23 is not output	A
DTC B1423/23 is output	B

B REPLACE A/C AMPLIFIER

A  END

DESCRIPTION

The air mix control servo motor sends pulse signals to indicate the damper position to the A/C amplifier. The A/C amplifier activates the motor (normal or reverse) based on these signals to move the air mix damper to any position. As a result, the amount of air passing through the heater core after passing through the evaporator is adjusted, and the temperature of the air blowing toward the passenger side is controlled.

The A/C amplifier communicates with the servo through a communication/driver IC and wiring assembly called the air conditioning harness.

HINT:

Confirm that no mechanical problem is present because this DTC can be stored when either a damper link or the damper is mechanically locked.

DTC No.	DTC Detection Condition	Trouble Area
B1441/41	Air mix damper position sensor value does not change even if A/C amplifier operates air mix control servo motor	<ul style="list-style-type: none"> Air mix control servo motor Air conditioning harness A/C amplifier

WIRING DIAGRAM

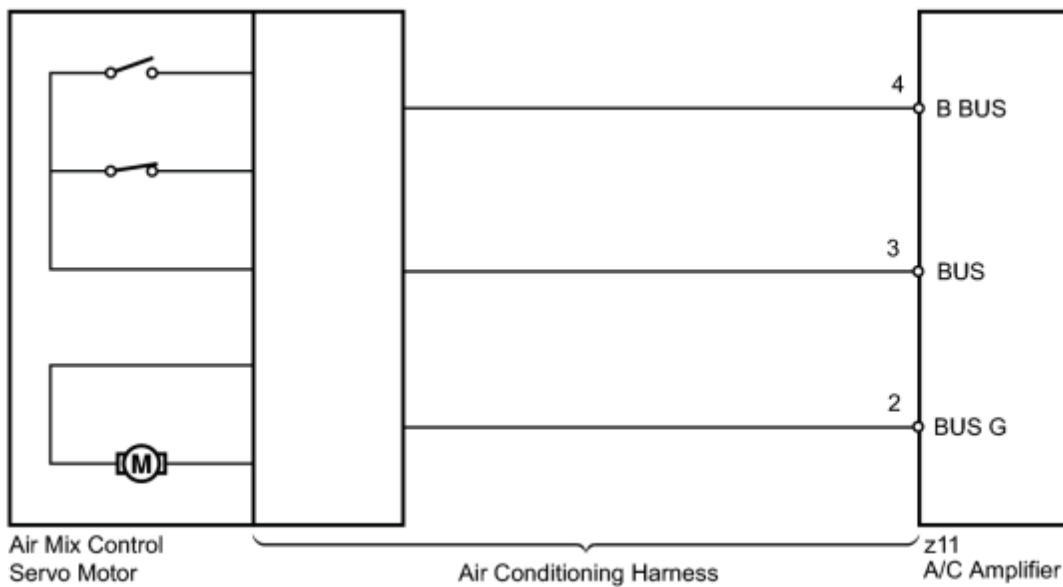

INSPECTION PROCEDURE

PROCEDURE

1.	READ VALUE USING TECHSTREAM
----	-----------------------------

- (a) Connect the Techstream to the DLC3.
- (b) Turn the power switch on (IG).
- (c) Turn the Techstream on.
- (d) Operate the temperature adjustment switch.
- (e) Enter the following menus: Body Electrical / Air Conditioner / Data List.
- (f) Check the value(s) by referring to the table below.

Air Conditioner

Tester Display	Measurement Item/Range	Normal Condition	Diagnostic Note
Air Mix Servo Targ Pulse (D)	Air mix servo motor target pulse / Min.: 0, Max.: 255	MAX. COLD: 6 (pulse) MAX. HOT: 93 (pulse)	-
Air Mix Servo Actual Pulse (D)	Air mix servo motor actual pulse / Min.: 0, Max.: 255	MAX. COLD: 6 (pulse) MAX. HOT: 93 (pulse)	-

OK:

The display is as specified in the Normal Condition column.

Result:

Result	Proceed to
NG	A
OK (When troubleshooting according to Problem Symptoms Table)	B
OK (When troubleshooting according to the DTC)	C

C ▶ REPLACE A/C AMPLIFIER

B ▶ PROCEED TO NEXT SUSPECTED AREA SHOWN IN PROBLEM SYMPTOMS TABLE

A



2. PERFORM ACTIVE TEST USING TECHSTREAM

- (a) Connect the Techstream to the DLC3.
- (b) Turn the power switch on (IG).
- (c) Turn the Techstream on.
- (d) Enter the following menus: Body Electrical / Air Conditioner / Active Test.
- (e) Check the operation by referring to the table below.

Air Conditioner

Tester Display	Test Part	Control Range	Diagnostic Note
Air Mix Servo Targ Pulse (D)	Air mix servo motor pulse	Min.: 0, Max.: 255	-

OK:

Air temperature changes in accordance with each control range.

NG  [INSPECT AIR MIX CONTROL SERVO MOTOR](#)

OK  **REPLACE A/C AMPLIFIER**

3. INSPECT AIR MIX CONTROL SERVO MOTOR

- (a) Replace the air mix control servo motor .

HINT:

Since the servo motor cannot be inspected while it is removed from the vehicle, replace the servo motor with a new or a known good one and check that the condition returns to normal.

- (b) Check for the DTC.

Result:

Result	Proceed to
DTC B1441/41 is output	A
DTC B1441/41 is not output	B

B  END (AIR MIX CONTROL SERVO MOTOR WAS DEFECTIVE)

A



4. INSPECT AIR CONDITIONING HARNESS

(a) Replace the air conditioning harness .

HINT:

Since the air conditioning harness cannot be inspected while it is removed from the vehicle, replace the air conditioning harness with a new or a known good one and check that the condition returns to normal.

(b) Check for the DTC.

Result:

Result	Proceed to
DTC B1441/41 is output	A
DTC B1441/41 is not output	B

B ▶ END (AIR CONDITIONING HARNESS WAS DEFECTIVE)

A ▶ REPLACE A/C AMPLIFIER

DESCRIPTION

The air inlet control servo motor sends pulse signals to indicate the damper position to the A/C amplifier. The A/C amplifier activates the motor (normal or reverse) based on these signals to move the air inlet mode selection air inlet control damper to any position, which controls the intake air settings (FRESH, FRESH/RECIRCULATION and RECIRCULATION).

The A/C amplifier communicates with the servo through a communication/driver IC and wiring assembly called the air conditioning harness.

HINT:

Confirm that no mechanical problem is present because this DTC can be stored when either a damper link or the damper is mechanically locked.

DTC No.	DTC Detection Condition	Trouble Area
B1442/42	Air inlet damper position sensor value does not change even if A/C amplifier operates air inlet control servo motor	<ul style="list-style-type: none"> • Air inlet control servo motor • Air conditioning harness • A/C amplifier

WIRING DIAGRAM

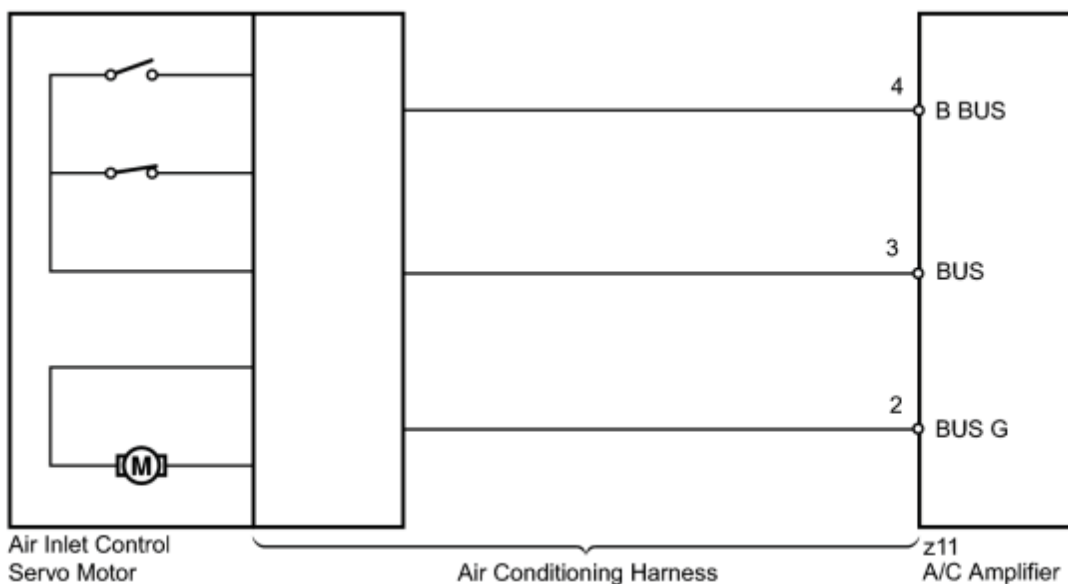

INSPECTION PROCEDURE

PROCEDURE

1. READ VALUE USING TECHSTREAM

- (a) Connect the Techstream to the DLC3.
- (b) Turn the power switch on (IG).
- (c) Turn the Techstream on.
- (d) Operate the R/F (Recirculation/Fresh) switch.
- (e) Enter the following menus: Body Electrical / Air Conditioner / Data List.
- (f) Check the value(s) by referring to the table below.

Air Conditioner

Tester Display	Measurement Item/Range	Normal Condition	Diagnostic Note
Air Inlet Damper Targ Pulse	Air inlet servo motor target pulse / Min.: 0, Max.: 255	RECIRCULATION: 19 (pulse) FRESH: 7 (pulse)	-
Air Inlet Damper Actual Pulse	Air inlet servo motor actual pulse / Min.: 0, Max.: 255	RECIRCULATION: 19 (pulse) FRESH: 7 (pulse)	-

OK:

The display is as specified in the Normal Condition column.

Result:

Result	Proceed to
NG	A
OK (When troubleshooting according to Problem Symptoms Table)	B
OK (When troubleshooting according to the DTC)	C

C ▶ REPLACE A/C AMPLIFIER

B ▶ PROCEED TO NEXT SUSPECTED AREA SHOWN IN PROBLEM SYMPTOMS TABLE

A



2. PERFORM ACTIVE TEST USING TECHSTREAM

- (a) Connect the Techstream to the DLC3.
- (b) Turn the power switch on (IG).
- (c) Turn the Techstream on.
- (d) Enter the following menus: Body Electrical / Air Conditioner / Active Test.
- (e) Check the operation by referring to the table below.

Air Conditioner

Tester Display	Test Part	Control Range	Diagnostic Note
Air Inlet Damper Targ Pulse	Air inlet damper target pulse	Min.: 0, Max.: 255	-

OK:

Recirculation damper position changes in accordance with each control range.

NG  INSPECT AIR INLET CONTROL SERVO MOTOR

OK  **REPLACE A/C AMPLIFIER**

3.	INSPECT AIR INLET CONTROL SERVO MOTOR
----	---------------------------------------

- (a) Replace the air inlet control servo motor .

HINT:

Since the servo motor cannot be inspected while it is removed from the vehicle, replace the servo motor with a new or a known good one and check that the condition returns to normal.

- (b) Check for the DTC.

Result:

Result	Proceed to
DTC B1442/42 is output	A
DTC B1442/42 is not output	B

B  END (AIR INLET CONTROL SERVO MOTOR WAS DEFECTIVE)

A



4.	INSPECT AIR CONDITIONING HARNESS
----	----------------------------------

- (a) Replace the air conditioning harness .

HINT:

Since the air conditioning harness cannot be inspected while it is removed from the vehicle, replace the air conditioning harness with a new or a known good one and check that the condition returns to normal.

(b) Check for the DTC.

Result:

Result	Proceed to
DTC B1442/42 is output	A
DTC B1442/42 is not output	B

B ▶ **END (AIR CONDITIONING HARNESS WAS DEFECTIVE)**

A ▶ **REPLACE A/C AMPLIFIER**

DESCRIPTION

The air outlet control servo motor sends pulse signals to indicate the damper position to the A/C amplifier. The A/C amplifier activates the motor (normal or reverse) based on these signals to move the mode damper to any position, which controls the air outlet switching.

The A/C amplifier communicates with the servo through a communication/driver IC and wiring assembly called the air conditioning harness.

HINT:

Confirm that no mechanical problem is present because this DTC can be stored when either a damper link or the damper is mechanically locked.

DTC No.	DTC Detection Condition	Trouble Area
B1443/43	Air outlet damper position sensor value does not change even if A/C amplifier operates air outlet control servo motor	<ul style="list-style-type: none"> • Air outlet control servo motor • Air conditioning harness • A/C amplifier

WIRING DIAGRAM

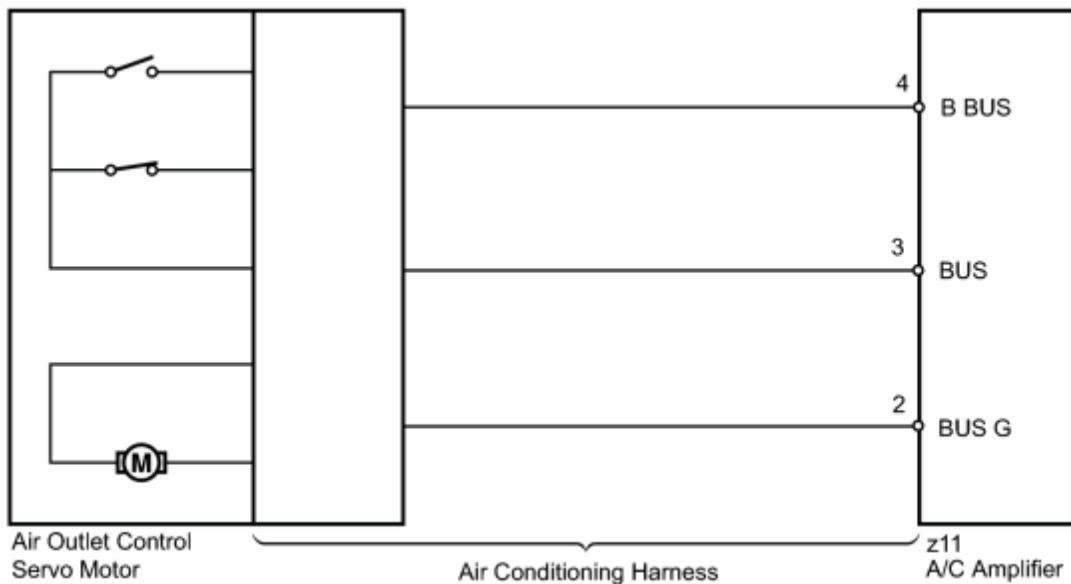

INSPECTION PROCEDURE

PROCEDURE

1.	READ VALUE USING TECHSTREAM
----	-----------------------------

- (a) Connect the Techstream to the DLC3.
- (b) Turn the power switch on (IG).
- (c) Turn the Techstream on.
- (d) Operate the MODE switch.
- (e) Enter the following menus: Body Electrical / Air Conditioner / Data List.
- (f) Check the value(s) by referring to the table below.

Air Conditioner

Tester Display	Measurement Item/Range	Normal Condition	Diagnostic Note
Air Outlet Servo Pulse (D)	Air outlet servo motor target pulse / Min.: 0, Max.: 255	FACE: 47 (pulse) B/L: 37 (pulse) FOOT: 17 (pulse) FOOT/DEF: 9 (pulse) DEF: 5 (pulse)	-
Air Outlet Servo Actu Pulse (D)	Air outlet servo motor actual pulse / Min.: 0, Max.: 255	FACE: 47 (pulse) B/L: 37 (pulse) FOOT: 17 (pulse) FOOT/DEF: 9 (pulse) DEF: 5 (pulse)	-

OK:

The display is as specified in the Normal Condition column.

Result:

Result	Proceed to
NG	A

Result	Proceed to
OK (When troubleshooting according to Problem Symptoms Table)	B
OK (When troubleshooting according to the DTC)	C

C ▶ REPLACE A/C AMPLIFIER

B ▶ PROCEED TO NEXT SUSPECTED AREA SHOWN IN PROBLEM SYMPTOMS TABLE

A



2.	PERFORM ACTIVE TEST USING TECHSTREAM
----	--------------------------------------

(a) Connect the Techstream to the DLC3.

(b) Turn the power switch on (IG).

(c) Turn the Techstream on.

(d) Enter the following menus: Body Electrical / Air Conditioner / Active Test.

(e) Check the operation by referring to the table below.

Air Conditioner

Tester Display	Test Part	Control Range	Diagnostic Note
Air Outlet Servo Pulse (D)	Air outlet servo motor pulse	Min.: 0, Max.: 255	-

OK:

Air flow position changes in accordance with each control range.

NG ▶ INSPECT AIR OUTLET CONTROL SERVO MOTOR

OK ▶ REPLACE A/C AMPLIFIER

3.	INSPECT AIR OUTLET CONTROL SERVO MOTOR
----	--

(a) Replace the air outlet control servo motor .

HINT:

Since the servo motor cannot be inspected while it is removed from the vehicle, replace the servo motor with a new or a known good one and check that the condition returns to normal.

(b) Check for the DTC.

Result:

Result	Proceed to
DTC B1443/43 is output	A
DTC B1443/43 is not output	B

B ▶ END (AIR OUTLET CONTROL SERVO MOTOR WAS DEFECTIVE)

A



4.	INSPECT AIR CONDITIONING HARNESS
----	----------------------------------

(a) Replace the air conditioning harness  .

HINT:

Since the air conditioning harness cannot be inspected while it is removed from the vehicle, replace the air conditioning harness with a new or a known good one and check that the condition returns to normal.

(b) Check for the DTC.

Result:

Result	Proceed to
DTC B1443/43 is output	A
DTC B1443/43 is not output	B

B ▶ END (AIR CONDITIONING HARNESS WAS DEFECTIVE)

A ▶ **REPLACE A/C AMPLIFIER**

DESCRIPTION

The A/C inverter assembly monitors power voltage from the main battery in the circuit. It stops compressor control and stores the DTC when the monitored voltage is outside the specified range.

The output DTC is memorized as previous trouble. Compressor control may not resume unless the power switch is turned off.

DTC No.	DTC Detection Condition	Trouble Area
B1471/71	<ul style="list-style-type: none"> • Open or short in A/C inverter high voltage power resource system. • The boost pressure system is broken or malfunctioning. 	<ul style="list-style-type: none"> • Electric vehicle fuse • No. 2 engine wire (harness or connector between compressor with motor assembly and inverter with converter assembly) • Compressor with motor assembly • Hybrid control system • CAN communication system

WIRING DIAGRAM

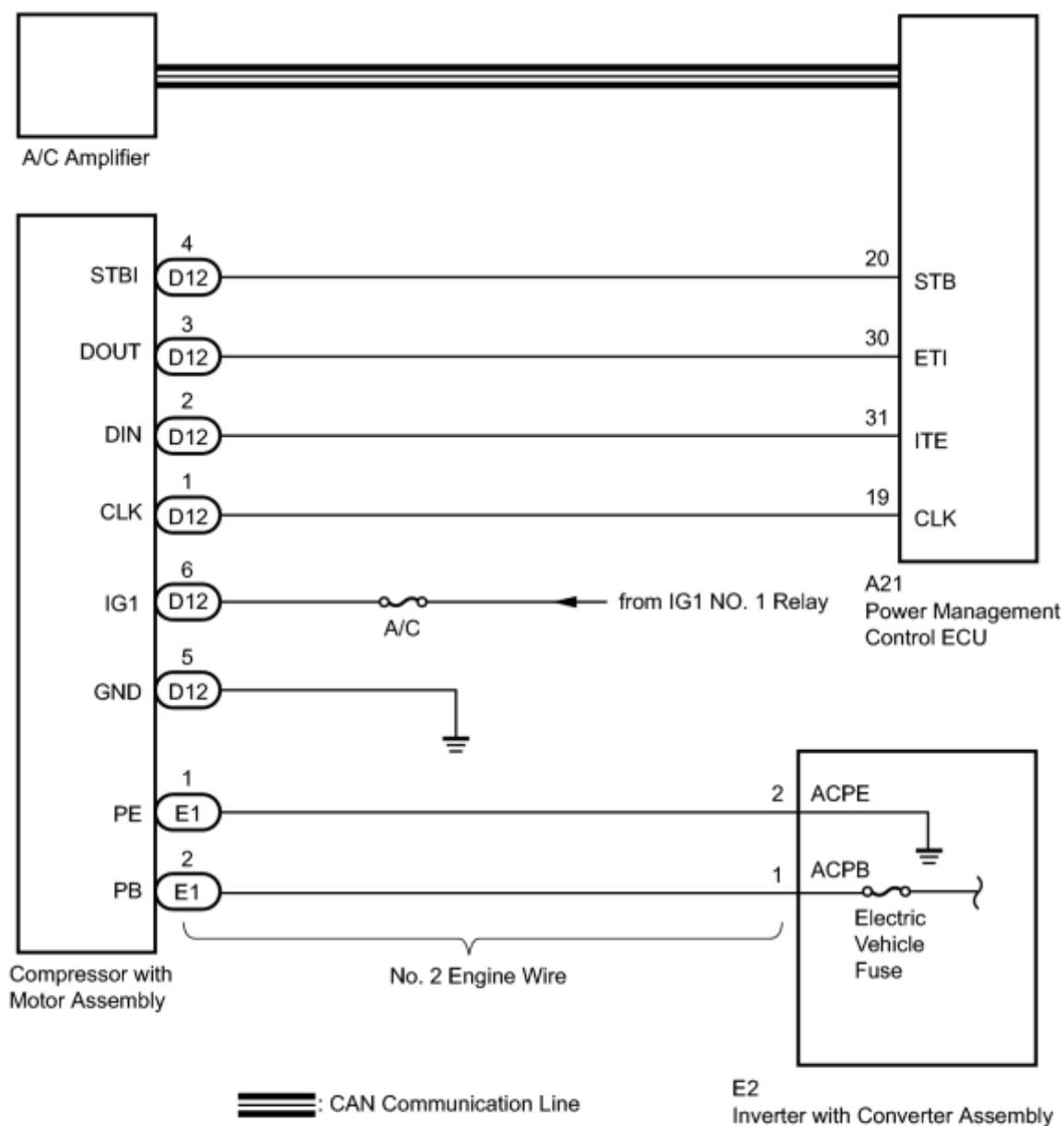

INSPECTION PROCEDURE

CAUTION:

- Wear electrically insulated gloves and pull out the service plug grip before inspection as procedures may require disconnecting high-voltage connectors. Be sure to carry the removed service plug grip because other workers may install it by mistake.
- Do not touch the high-voltage connectors or terminals for 10 minutes after the service plug grip is removed.

NOTICE:

The hybrid control system and air conditioning system output DTCs separately. Inspect DTCs following the flow chart for the hybrid control system first if any DTCs from those systems are output simultaneously.

PROCEDURE

1. CHECK CAN COMMUNICATION SYSTEM

(a) Using the Techstream to check if the CAN communication system is functioning normally.

Result:

Result	Proceed to
CAN DTC is not output	A
CAN DTC is output	B

B ▶ GO TO CAN COMMUNICATION SYSTEM

A



2. CHECK DIAGNOSTIC TROUBLE CODE (HYBRID CONTROL SYSTEM)

(a) Check if DTCs for the hybrid control system are output using the Techstream.

OK:

Hybrid control system DTCs are not output.

NG ▶ GO TO HYBRID CONTROL SYSTEM

OK



3. INSPECT ELECTRIC VEHICLE FUSE

CAUTION:

Be sure to wear insulated gloves.

(a) Turn the power switch off.

(b) Remove the service plug grip.

CAUTION:

Do not touch the high-voltage connectors or terminals for 10 minutes after the service plug grip is removed.

NOTICE:

2010 Toyota Prius

Repair Manual

Do not start the engine with the service plug grip removed because it may cause a malfunction.

(c) Remove the inverter terminal cover.

NOTICE:

Be sure to prevent foreign objects or water from entering the inverter with converter assembly.

*1

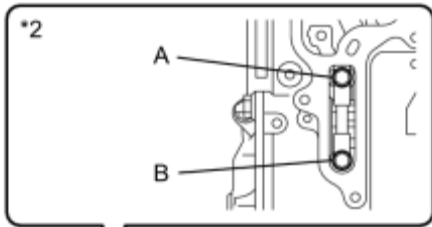

(d) Check that bolts A and B are tightened securely.

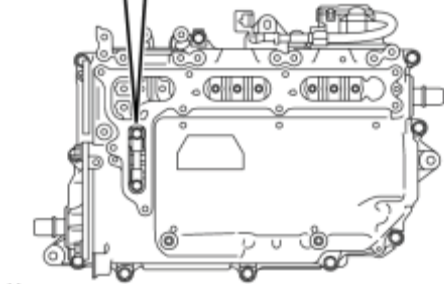

H

(e) Measure the resistance according to the value(s) in the table below.

Standard Resistance:

Tester Item (Tester Connection)	Condition	Specified Condition
ELECTRIC VEHICLE fuse (A - B)	Always	Below 1 Ω

Text in Illustration

*1	Inverter with Converter Assembly
*2	Electric Vehicle Fuse

NG REPLACE ELECTRIC VEHICLE FUSE

OK



4.	INSPECT NO. 2 ENGINE WIRE
----	---------------------------

CAUTION:

Be sure to wear insulated gloves.

*1

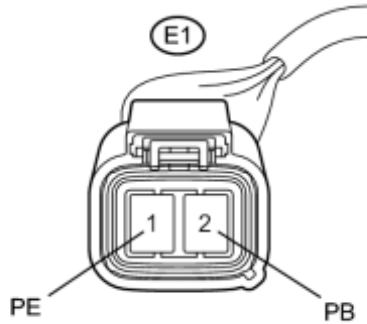

(a) Disconnect the No. 2 engine wire connector.

(b) Measure the resistance according to the value(s) in the table below.

Standard Resistance:

*2

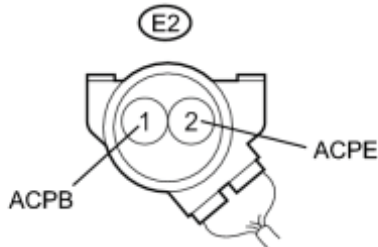

Tester Connection	Condition	Specified Condition
E1-1 (PE) - E2-2 (ACPE)	Always	Below 1 Ω
E1-2 (PB) - E2-1 (ACPB)	Always	Below 1 Ω
E1-1 (PE) - Body ground	Always	10 k Ω or higher
E1-2 (PB) - Body ground	Always	10 k Ω or higher

Text in Illustration

H

*1	Front view of wire harness connector (to Compressor with Motor Assembly)
*2	Front view of wire harness connector (to Inverter with Converter Assembly)

NG REPLACE NO. 2 ENGINE WIRE

OK REPLACE COMPRESSOR WITH MOTOR ASSEMBLY

DESCRIPTION

The inverter in the compressor with motor assembly outputs high-voltage to operate the motor. If there is an open or short in the output circuit, the ECU will stop compressor operation and output the DTC. The output DTC will be memorized as a history DTC. The compressor operation remains stopped until both the history and current DTCs are cleared.

DTC No.	DTC Detection Condition	Trouble Area
B1472/72	Open or short in A/C inverter high voltage output system.	<ul style="list-style-type: none"> Compressor with motor assembly CAN communication system

INSPECTION PROCEDURE

CAUTION:

- Wear electrically insulated gloves and pull out the service plug grip before inspection as procedures may require disconnecting high-voltage connectors. Be sure to carry the removed service plug grip because other workers may install it by mistake.
- Do not touch the high-voltage connectors or terminals for 10 minutes after the service plug grip is removed.

NOTICE:

The hybrid control system and air conditioning system output DTCs separately. Inspect DTCs following the flow chart for the hybrid control system first if any DTCs from those systems are output simultaneously.

PROCEDURE

1.	CHECK CAN COMMUNICATION SYSTEM
----	--------------------------------

(a) Using the Techstream to check if the CAN communication system is functioning normally.

Result:

Result	Proceed to
CAN DTC is not output	A
CAN DTC is output	B

B ▶ GO TO CAN COMMUNICATION SYSTEM

A ▶ REPLACE COMPRESSOR WITH MOTOR ASSEMBLY

DESCRIPTION

The inverter activation signal is sent to the compressor with motor assembly from the power management control ECU. Compressor control is stopped and the DTC is stored if there is an open or short in the signal circuit.

DTC No.	DTC Detection Condition	Trouble Area
B1473/73	Open or short in A/C inverter start-up signal system.	<ul style="list-style-type: none">• Harness or connector between power management control ECU and compressor with motor assembly• Compressor with motor assembly• Power management control ECU• Hybrid control system• CAN communication system

WIRING DIAGRAM

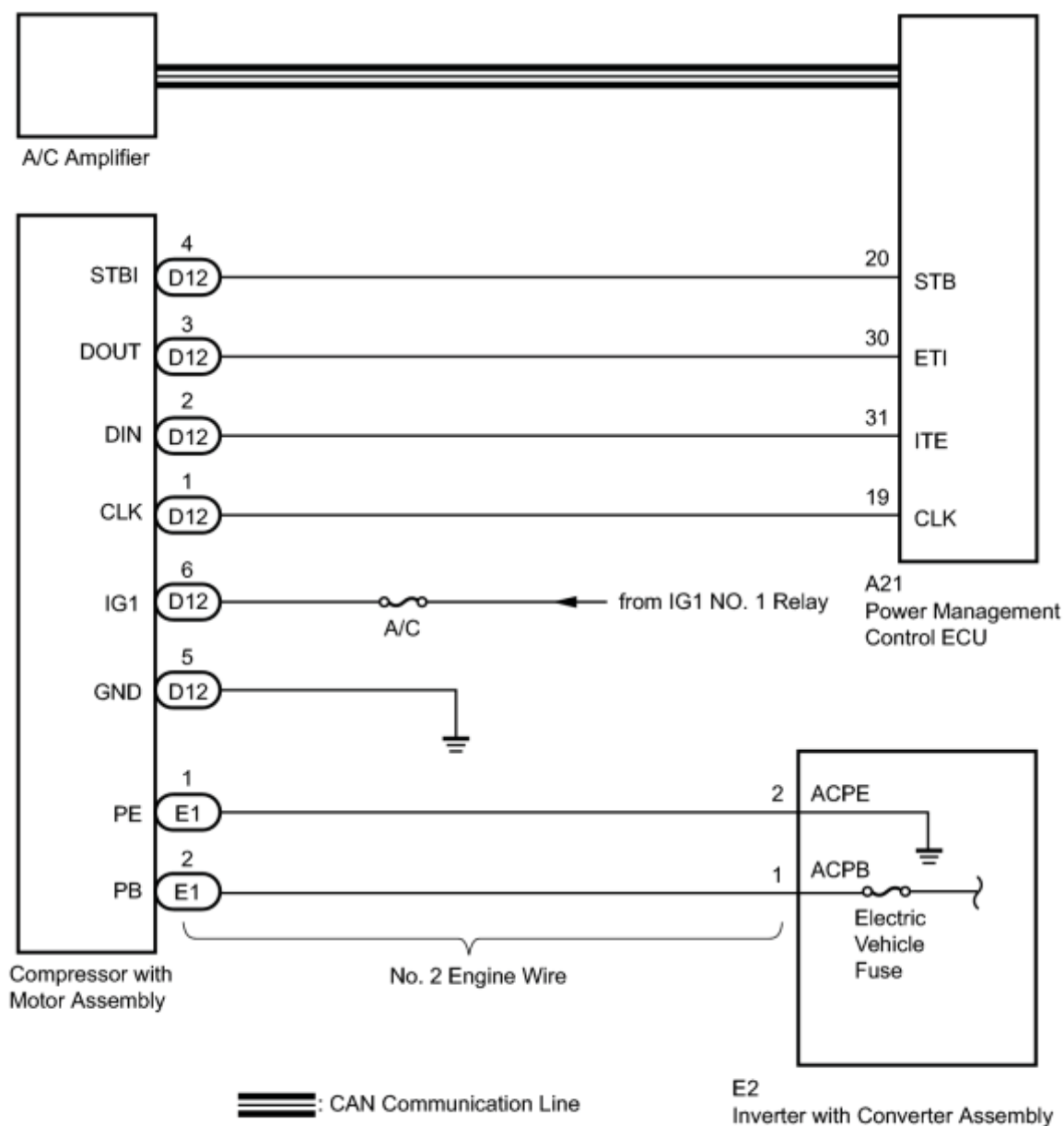

INSPECTION PROCEDURE

CAUTION:

- Wear electrically insulated gloves and pull out the service plug grip before inspection as procedures may require disconnecting high-voltage connectors. Be sure to carry the removed service plug grip because other workers may install it by mistake.
- Do not touch the high-voltage connectors or terminals for 10 minutes after the service plug grip is removed.

NOTICE:

The hybrid control system and air conditioning system output DTCs separately. Inspect DTCs following the flow chart for the hybrid control system first if any DTCs from those systems are output simultaneously.

PROCEDURE

1.	CHECK CAN COMMUNICATION SYSTEM
----	--------------------------------

(a) Using the Techstream to check if the CAN communication system is functioning normally.

Result:

Result	Proceed to
CAN DTC is not output	A
CAN DTC is output	B

 GO TO CAN COMMUNICATION SYSTEM

A



2.	CHECK DIAGNOSTIC TROUBLE CODE
----	-------------------------------

(a) Check if DTCs for the air conditioning system and the hybrid control system are output using the Techstream.

Result:

Result	Proceed to
Only DTC B1473 is output	A
DTCs B1473 and P3108 are output simultaneously (B1498 is not output)	
DTCs B1473 and B1498 are output simultaneously (P3108 is not output)	B
DTCs B1473, B1498 and P3108 are output simultaneously	
DTCs other than P3108 are output for hybrid control system	C

 GO TO HYBRID CONTROL SYSTEM

 GO TO DTC B1498/98

A



3.	CHECK HARNESS AND CONNECTOR (POWER MANAGEMENT CONTROL ECU - COMPRESSOR WITH MOTOR)
----	--

CAUTION:

Do not disconnect the connector on the high-voltage side.

*1



(a) Disconnect the connector from the power management control ECU.

*2

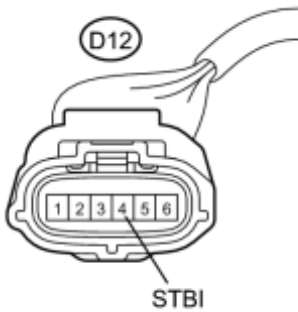

(b) Disconnect the connector from the compressor with motor assembly.

H

(c) Measure the resistance according to the value(s) in the table below.

Standard Resistance:

Tester Connection	Condition	Specified Condition
A21-20 (STB) - D12-4 (STBI)	Always	Below 1 Ω
A21-20 (STB) - Body ground	Always	10 k Ω or higher

Text in Illustration

*1	Front view of wire harness connector (to Power Management Control ECU)
*2	Front view of wire harness connector (to Compressor with Motor Assembly)

NG REPAIR OR REPLACE HARNESS OR CONNECTOR

OK



4. INSPECT COMPRESSOR WITH MOTOR ASSEMBLY

(a) Reconnect the connector to the compressor with motor assembly.

(b) Measure the voltage according to the value(s) in the table below.

Standard Voltage:

*1



Tester Connection	Condition	Specified Condition
A21-20 (STB) - Body ground	Power switch on (IG)	11 to 14 V
A21-20 (STB) - Body ground	Power switch off	Below 1 V

Text in Illustration

*1	Front view of wire harness connector (to Power Management Control ECU)
----	---

NG ▶ REPLACE COMPRESSOR WITH MOTOR ASSEMBLY

OK ▶ REPLACE POWER MANAGEMENT CONTROL ECU

DESCRIPTION

DTC No.	DTC Detecting Condition	Trouble Area
B1474/74	A/C inverter malfunction	<ul style="list-style-type: none"> Compressor with motor assembly CAN communication system

INSPECTION PROCEDURE

CAUTION:

- Wear electrically insulated gloves and pull out the service plug grip before inspection as procedures may require disconnecting high-voltage connectors. Be sure to carry the removed service plug grip because other workers may install it by mistake.
- Do not touch the high-voltage connectors or terminals for 10 minutes after the service plug grip is removed.

NOTICE:

The hybrid control system and air conditioning system output DTCs separately. Inspect DTCs following the flow chart for the hybrid control system first if any DTCs from those systems are output simultaneously.

PROCEDURE

1.	CHECK CAN COMMUNICATION SYSTEM
----	--------------------------------

(a) Using the Techstream to check if the CAN communication system is functioning normally.

Result:

Result	Proceed to
CAN DTC is not output	A
CAN DTC is output	B

B ▶ GO TO CAN COMMUNICATION SYSTEM

A ▶ REPLACE COMPRESSOR WITH MOTOR ASSEMBLY

DESCRIPTION

The temperature sensor of the compressor with motor assembly detects inverter temperature.

If the temperature exceeds the maximum, the compressor with motor assembly stops compressor operation, and this DTC will be stored.

DTC No.	DTC Detection Condition	Trouble Area
B1475/75	Cooling water temperature in the inverter is outside the specified range (temperature is too high), or there is an open or short to ground in the temperature sensor circuit.	<ul style="list-style-type: none"> • Cooling fan system • Refrigerant volume • Compressor with motor assembly • CAN communication system

INSPECTION PROCEDURE

CAUTION:

- Wear electrically insulated gloves and pull out the service plug grip before inspection as procedures may require disconnecting high-voltage connectors. Be sure to carry the removed service plug grip because other workers may install it by mistake.
- Do not touch the high-voltage connectors or terminals for 10 minutes after the service plug grip is removed.

NOTICE:

The hybrid control system and air conditioning system output DTCs separately. Inspect DTCs following the flow chart for the hybrid control system first if any DTCs from those systems are output simultaneously.

PROCEDURE

1.	CHECK CAN COMMUNICATION SYSTEM
----	--------------------------------

(a) Using the Techstream to check if the CAN communication system is functioning normally.

Result:

Result	Proceed to
CAN DTC is not output	A
CAN DTC is output	B

 GO TO CAN COMMUNICATION SYSTEM

A



2. PERFORM ACTIVE TEST USING TECHSTREAM

- (a) Connect the Techstream to the DLC3.
- (b) Turn the power switch on (IG).
- (c) Turn the Techstream on.
- (d) Enter the following menus: Body Electrical / Air Conditioner / Active Test.
- (e) Check the operation by referring to the table below.

Air Conditioner

Tester Display	Test Part	Control Range	Diagnostic Note
Electrical Fan	Electrical fan	OFF or ON	-

OK:

Electrical fan operates smoothly.

NG ► GO TO COOLING FAN SYSTEM

OK



3. CHECK REFRIGERANT PRESSURE

- (a) Install the manifold gauge set .
- (b) Read the manifold gauge pressure when the following conditions are established.
 - (1) Prepare the vehicle according to the chart below.

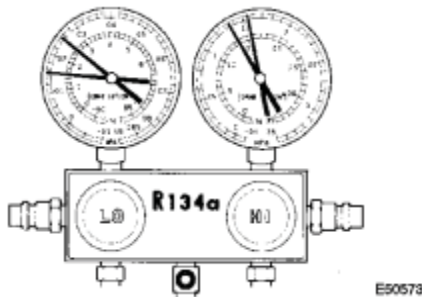

Item	Condition
Vehicle Doors	All fully open
Temperature Setting	MAX COLD
Blower Speed	HI
A/C switch	ON
R/F Switch	RECIRCULATION (30 to 35°C (86 to 95°F))

Standard Pressure:

Low pressure side

0.15 to 0.25 MPa (1.5 to 2.5 kgf/cm², 21.3 to 35.6 psi)

High pressure side

1.37 to 1.57 MPa (14 to 16 kgf/cm², 199 to 228 psi)

NG  CHARGE REFRIGERANT

OK



4. READ OUTPUT DTC (DTC B1475/75)

(a) Clear the DTCs .

(b) Prepare the vehicle according to the table below.

Item	Condition
Engine speed	Engine idling
Blower speed	HI
A/C switch	ON
Temperature setting	MAX. COLD

(c) Check for DTCs .

Result:

Result	Proceed to
DTC B1475/75 is not output (normal)	A
DTC B1475/75 is output	B

NOTICE:

If the engine keeps idling when ambient temperature is high, the compressor may automatically stop to protect the inverter circuit, and DTC B1475/75 may be stored.

B  REPLACE COMPRESSOR WITH MOTOR ASSEMBLY

A  SYSTEM IS OK

DESCRIPTION

The compressor with motor assembly stops compressor control and outputs this DTC if the rotation load is too large or too small while controlling motor rotation in the compressor with motor assembly.

Possible causes are refrigerant gas leakage, overcharged refrigerant gas, insufficient cooling because of a condenser fan circuit malfunction, or compressor lock.

DTC No.	DTC Detection Condition	Trouble Area
B1476/76	Motor rotation load while the compressor is operating is too large or too small.	<ul style="list-style-type: none"> • Refrigerant volume • Compressor with motor assembly • Cooling fan system • CAN communication system

INSPECTION PROCEDURE

CAUTION:

- Wear electrically insulated gloves and pull out the service plug grip before inspection as procedures may require disconnecting high-voltage connectors. Be sure to carry the removed service plug grip because other workers may install it by mistake.
- Do not touch the high-voltage connectors or terminals for 10 minutes after the service plug grip is removed.

NOTICE:

The hybrid control system and air conditioning system output DTCs separately. Inspect DTCs following the flow chart for the hybrid control system first if any DTCs from those systems are output simultaneously.

PROCEDURE

1.	CHECK CAN COMMUNICATION SYSTEM
----	--------------------------------

(a) Using the Techstream to check if the CAN communication system is functioning normally.

Result:

Result	Proceed to
CAN DTC is not output	A
CAN DTC is output	B

B  GO TO CAN COMMUNICATION SYSTEM

A



2. PERFORM ACTIVE TEST USING TECHSTREAM

- (a) Connect the Techstream to the DLC3.
- (b) Turn the power switch on (IG).
- (c) Turn the Techstream on.
- (d) Enter the following menus: Body Electrical / Air Conditioner / Active Test.
- (e) Check the operation by referring to the table below.

Air Conditioner

Tester Display	Test Part	Control Range	Diagnostic Note
Electrical Fan	Electrical fan	OFF or ON	-

NG ► GO TO COOLING FAN SYSTEM

OK



3. CHECK REFRIGERANT PRESSURE

- (a) Install the manifold gauge set INFO.
- (b) Read the manifold gauge pressure when the following conditions are established.
 - (1) Prepare the vehicle according to the chart below.

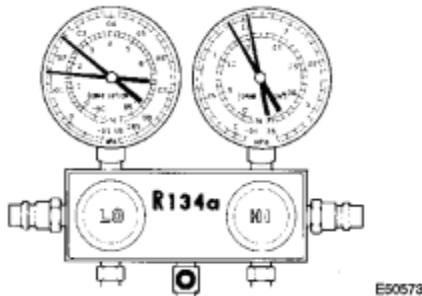

Item	Condition
Vehicle Doors	All fully open
Temperature Setting	MAX COLD
Blower Speed	HI
A/C switch	ON
R/F Switch	RECIRCULATION (30 to 35°C (86 to 95°F))

Standard Pressure:

Low pressure side

0.15 to 0.25 MPa (1.5 to 2.5 kgf/cm², 21.3 to 35.6 psi)

High pressure side

1.37 to 1.57 MPa (14 to 16 kgf/cm², 199 to 228 psi)

NG ► CHARGE REFRIGERANT

OK ► **REPLACE COMPRESSOR WITH MOTOR ASSEMBLY**

DESCRIPTION

The compressor with motor assembly monitors the controlling power voltage in the circuit. It stops the compressor circuit and stores the DTC when the monitored voltage is outside the specified range.

The output DTC is memorized as previous trouble. The compressor control may not resume unless the power switch is turned off.

DTC No.	DTC Detection Condition	Trouble Area
B1477/77	An open or short to ground in the inverter controlling power voltage circuit.	<ul style="list-style-type: none"> Compressor with motor assembly CAN communication system

INSPECTION PROCEDURE

CAUTION:

- Wear electrically insulated gloves and pull out the service plug grip before inspection as procedures may require disconnecting high-voltage connectors. Be sure to carry the removed service plug grip because other workers may install it by mistake.
- Do not touch the high-voltage connectors or terminals for 10 minutes after the service plug grip is removed.

NOTICE:

The hybrid control system and air conditioning system output DTCs separately. Inspect DTCs following the flow chart for the hybrid control system first if any DTCs from those systems are output simultaneously.

PROCEDURE

1.	CHECK CAN COMMUNICATION SYSTEM
----	--------------------------------

(a) Using the Techstream to check if the CAN communication system is functioning normally.

Result:

Result	Proceed to
CAN DTC is not output	A
CAN DTC is output	B

B ▶ GO TO CAN COMMUNICATION SYSTEM

A ▶ REPLACE COMPRESSOR WITH MOTOR ASSEMBLY

DESCRIPTION

The air conditioning harness connects the A/C amplifier and each servo. The A/C amplifier supplies power and sends operation instructions to each servo through the air conditioning harness. Each servo sends the damper position information to the A/C amplifier.

DTC No.	DTC Detection Condition	Trouble Area
B1497/97	Communication line error or open	<ul style="list-style-type: none"> Air conditioning harness A/C amplifier

WIRING DIAGRAM

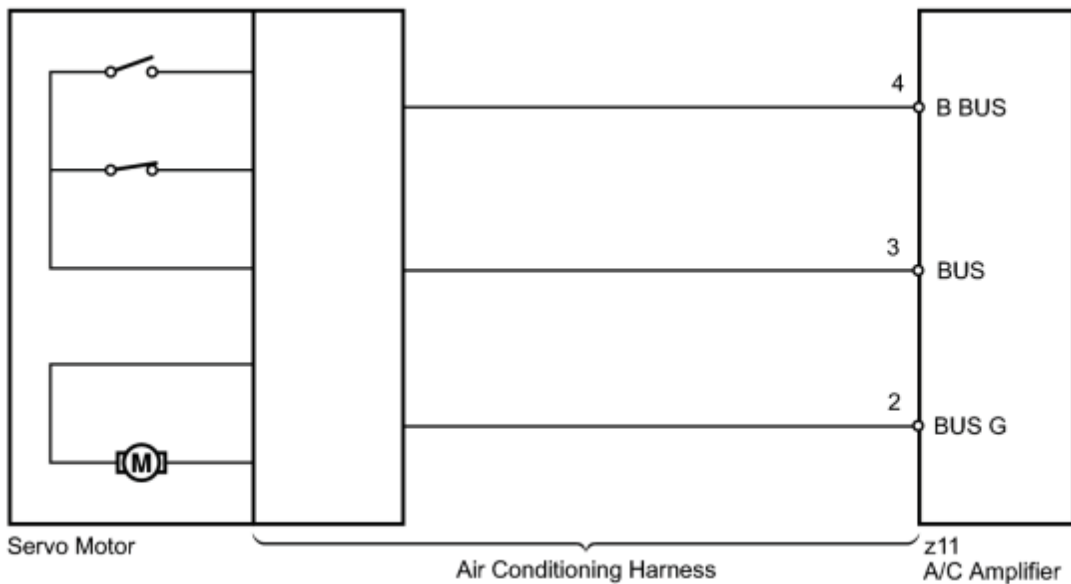

INSPECTION PROCEDURE

PROCEDURE

1. INSPECT A/C AMPLIFIER

(a) Remove the A/C amplifier with the connectors still connected.

*1

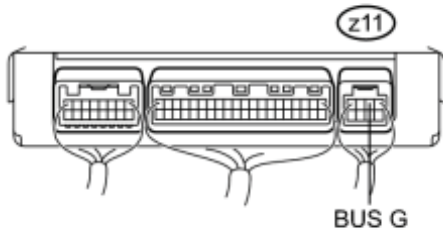

(b) Measure the resistance according to the value(s) in the table below.

Standard Resistance:

Tester Connection	Condition	Specified Condition
z11-2 (BUS G) - Body ground	Always	Below 1 Ω

Text in Illustration

*1	Component with harness connected (A/C Amplifier)
----	---

NG ▶ REPLACE A/C AMPLIFIER

OK



2.	INSPECT A/C AMPLIFIER
----	-----------------------

(a) Measure the voltage according to the value(s) in the table below.

Standard Voltage:

*1

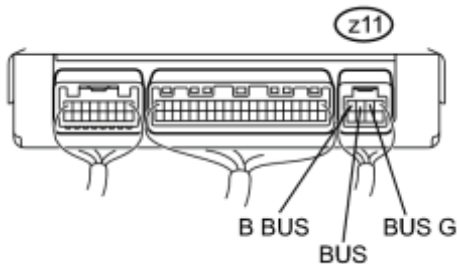

Tester Connection	Condition	Specified Condition
z11-4 (B BUS) - z11-2 (BUS G)	Power switch off	Below 1 V
z11-4 (B BUS) - z11-2 (BUS G)	Power switch on (IG)	11 to 14 V
z11-3 (BUS) - z11-2 (BUS G)	Power switch on (IG)	Pulse generation

Text in Illustration

*1	Component with harness connected (A/C Amplifier)
----	---

NG  REPLACE A/C AMPLIFIER

OK  REPLACE AIR CONDITIONING HARNESS

DESCRIPTION

The power management control ECU and compressor with motor assembly transmit information to one another via a communication line. Compressor control is stopped and the DTC is stored if communication information is cut off or abnormal information occurs.

The DTC is also detected if high-voltage power supplied from the inverter with converter assembly to the compressor control circuit is shut off.

The output DTC is memorized as previous trouble.

DTC No.	DTC Detection Condition	Trouble Area
B1498/98	<ul style="list-style-type: none"> • Communication line error or open between the power management control ECU and compressor with motor assembly. • High-voltage power source is shut off. 	<ul style="list-style-type: none"> • Harness or connector between power management control ECU, compressor with motor assembly and body ground • Power management control ECU • Compressor with motor assembly • No. 2 engine wire (harness or connector between compressor with motor assembly and inverter with converter assembly) • Electric vehicle fuse • CAN communication system • Hybrid control system

WIRING DIAGRAM

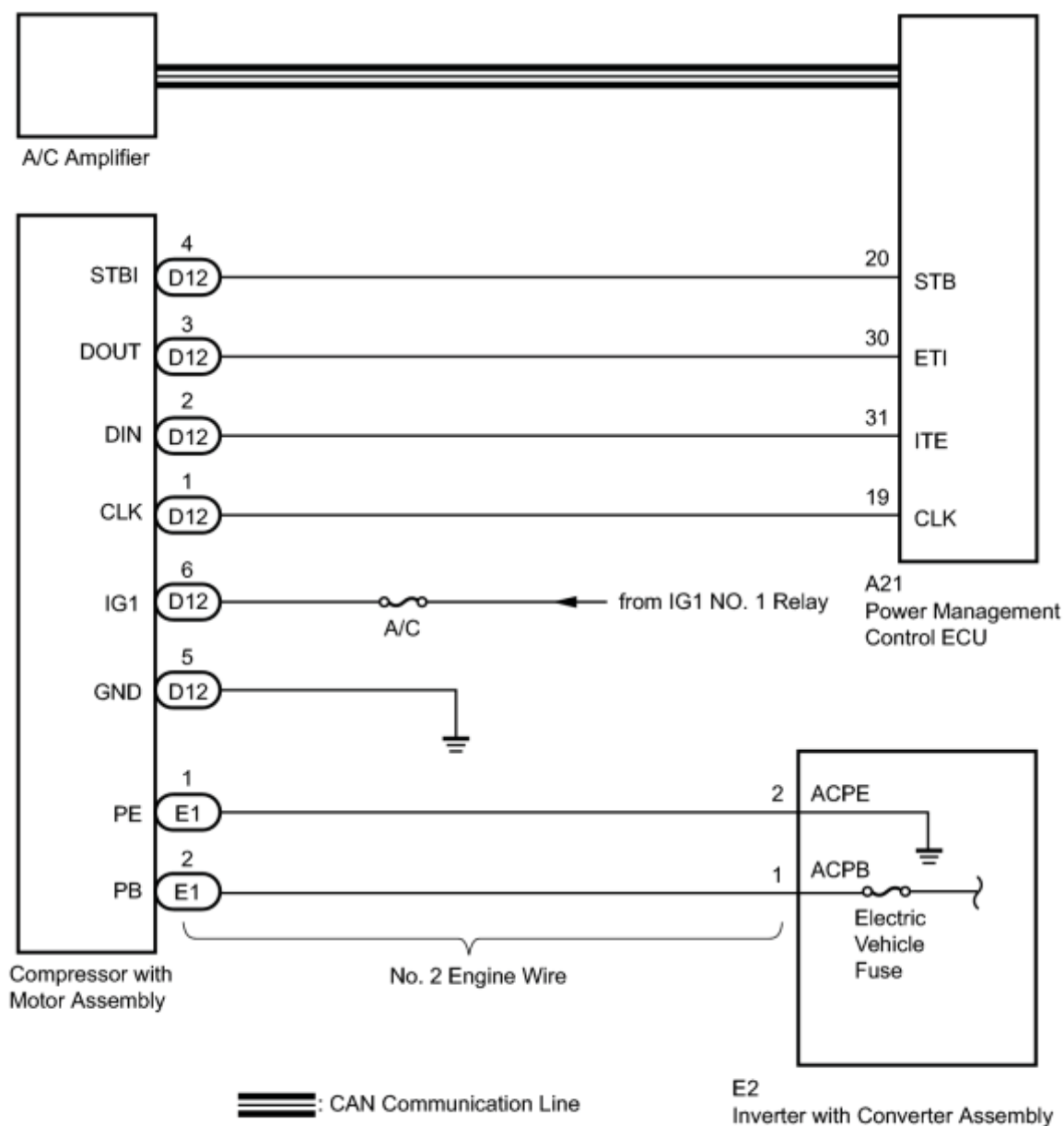

INSPECTION PROCEDURE

CAUTION:

- Wear electrically insulated gloves and pull out the service plug grip before inspection as procedures may require disconnecting high-voltage connectors. Be sure to carry the removed service plug grip because other workers may install it by mistake.
- Do not touch the high-voltage connectors or terminals for 10 minutes after the service plug grip is removed.

NOTICE:

- The hybrid control system and air conditioning system output DTCs separately. Inspect DTCs following the flow chart for the hybrid control system first if any DTCs from those systems are output simultaneously.
- Depending on the timing of the power supply to the 12 V power supply circuit and high-voltage circuit when the power switch is turned on (READY), an abnormal information signal may be output, causing this DTC to be stored. If the output DTC is a code that was memorized in the past, check the fuses and wire harnesses. If there is no malfunction, clear the DTC.
- Inspect the fuses for circuits related to this system before performing the following inspection procedure.

PROCEDURE

1. CHECK CAN COMMUNICATION SYSTEM

(a) Using the Techstream to check if the CAN communication system is functioning normally.

Result:

Result	Proceed to
CAN DTC is not output	A
CAN DTC is output	B

 GO TO CAN COMMUNICATION SYSTEM

A



2. CHECK DIAGNOSTIC TROUBLE CODE

(a) Check if DTCs for the hybrid control system are output using the Techstream.

Result:

Result	Proceed to
DTC is not output	A
Only DTC P3108 is output	A
DTCs other than P3108 are output	B

 GO TO HYBRID CONTROL SYSTEM

A



3. CHECK HARNESS AND CONNECTOR (COMPRESSOR WITH MOTOR ASSEMBLY - BODY GROUND)

CAUTION:

Do not disconnect the connector on the high-voltage side.

*1

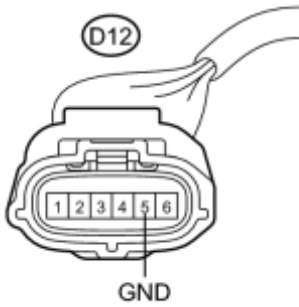

H

(a) Disconnect the connector from the compressor with motor assembly.

(b) Measure the resistance according to the value(s) in the table below.

Standard Resistance:

Tester Connection	Condition	Specified Condition
D12-5 (GND) - Body ground	Always	Below 1 Ω

Text in Illustration

*1	Front view of wire harness connector (to Compressor with Motor Assembly)
----	---

NG ► REPAIR OR REPLACE HARNESS OR CONNECTOR

OK



4.	CHECK HARNESS AND CONNECTOR (COMPRESSOR WITH MOTOR ASSEMBLY - BATTERY, GROUND)
----	--

(a) Turn the power switch on (IG).

*1

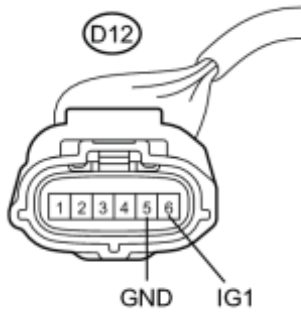

H

(b) Measure the voltage according to the value(s) in the table below.

Standard Voltage:

Tester Connection	Condition	Specified Condition
D12-6 (IG1) - D12-5 (GND)	Power switch on (IG)	11 to 14 V
D12-6 (IG1) - D12-5 (GND)	Power switch off	Below 1 V

Text in Illustration

*1	Front view of wire harness connector (to Compressor with Motor Assembly)
----	---

NG ► REPAIR OR REPLACE HARNESS OR CONNECTOR

OK



5.	CHECK HARNESS AND CONNECTOR (POWER MANAGEMENT CONTROL ECU - COMPRESSOR WITH MOTOR)
----	--

(a) Disconnect the connector from the power management control ECU.

*1



(b) Measure the resistance according to the value(s) in the table below.

Standard Resistance:

Tester Connection	Condition	Specified Condition
D12-1 (CLK) - A21-19 (CLK)	Always	Below 1 Ω
D12-2 (DIN) - A21-31 (ITE)	Always	Below 1 Ω
D12-3 (DOUT) - A21-30 (ETI)	Always	Below 1 Ω
D12-1 (CLK) - Body ground	Always	10 k Ω or higher
D12-2 (DIN) - Body ground	Always	10 k Ω or higher
D12-3 (DOUT) - Body ground	Always	10 k Ω or higher

*2

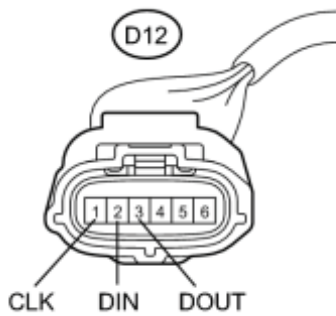

H

Text in Illustration

*1	Front view of wire harness connector (to Power Management Control ECU)
*2	Front view of wire harness connector (to Compressor with Motor Assembly)

NG REPAIR OR REPLACE HARNESS OR CONNECTOR

OK



6. INSPECT ELECTRIC VEHICLE FUSE

CAUTION:

Be sure to wear insulated gloves.

(a) Turn the power switch off.

(b) Remove the service plug grip.

CAUTION:

Do not touch the high-voltage connectors or terminals for 10 minutes after the service plug grip is removed.

NOTICE:

Do not start the engine with the service plug grip removed because it may cause a malfunction.

(c) Remove the inverter terminal cover.

NOTICE:

Be sure to prevent foreign objects or water from entering the inverter with converter assembly.

*1

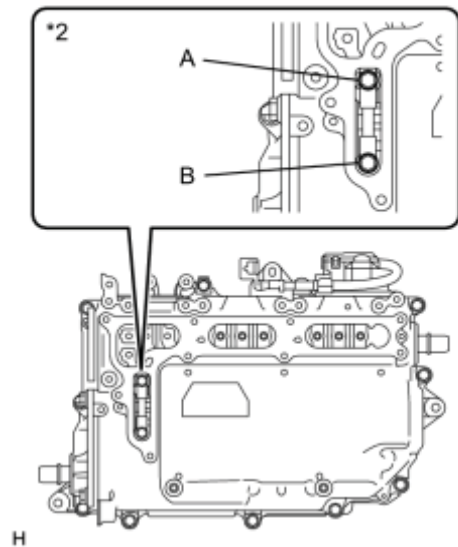

(d) Check that bolts A and B are tightened securely.

(e) Measure the resistance according to the value(s) in the table below.

Standard Resistance:

Tester Item (Tester Connection)	Condition	Specified Condition
ELECTRIC VEHICLE fuse (A - B)	Always	Below 1 Ω

Text in Illustration

*1 Inverter with Converter Assembly

NG▶ REPLACE ELECTRIC VEHICLE FUSE

OK



7.	INSPECT NO. 2 ENGINE WIRE
----	---------------------------

CAUTION:

Be sure to wear insulated gloves.

*1

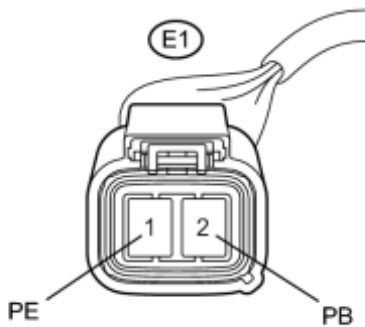

(a) Disconnect the No. 2 engine wire connector.

(b) Measure the resistance according to the value(s) in the table below.

Standard Resistance:

*2

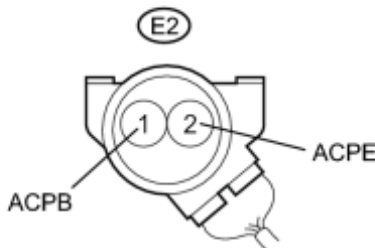

Tester Connection	Condition	Specified Condition
E1-1 (PE) - E2-2 (ACPE)	Always	Below 1 Ω
E1-2 (PB) - E2-1 (ACPB)	Always	Below 1 Ω
E1-1 (PE) - Body ground	Always	10 kΩ or higher
E1-2 (PB) - Body ground	Always	10 kΩ or higher

Text in Illustration

H

*1	Front view of wire harness connector (to Compressor with Motor Assembly)
*2	Front view of wire harness connector (to Inverter with Converter Assembly)

NG ▶ REPLACE NO. 2 ENGINE WIRE

OK



8.	REPLACE COMPRESSOR WITH MOTOR ASSEMBLY
----	--

(a) Replace the compressor with motor assembly NFC.

HINT:

Since the compressor with motor assembly cannot be inspected while it is removed from the vehicle, replace the compressor with motor assembly with a new or a known good one and check that the condition returns to normal.

(b) Check for the DTC.

Result:

Result	Proceed to
DTC B1498/98 is not output	A
DTC B1498/98 is output	B

B ▶ REPLACE POWER MANAGEMENT CONTROL ECU

A ▶ **END (COMPRESSOR WITH MOTOR ASSEMBLY WAS DEFECTIVE)**

DESCRIPTION

The plasmacluster (ion generator) operates in conjunction with blower switch operation.

DTC No.	DTC Detection Condition	Trouble Area
B14A1	Open in plasmacluster (ion generator) circuit	<ul style="list-style-type: none"> • Plasmacluster (ion generator) • Harness or connector between plasmacluster (ion generator) and A/C amplifier • Harness or connector between plasmacluster (ion generator) and battery • Harness or connector between plasmacluster (ion generator) and body ground • A/C amplifier

WIRING DIAGRAM

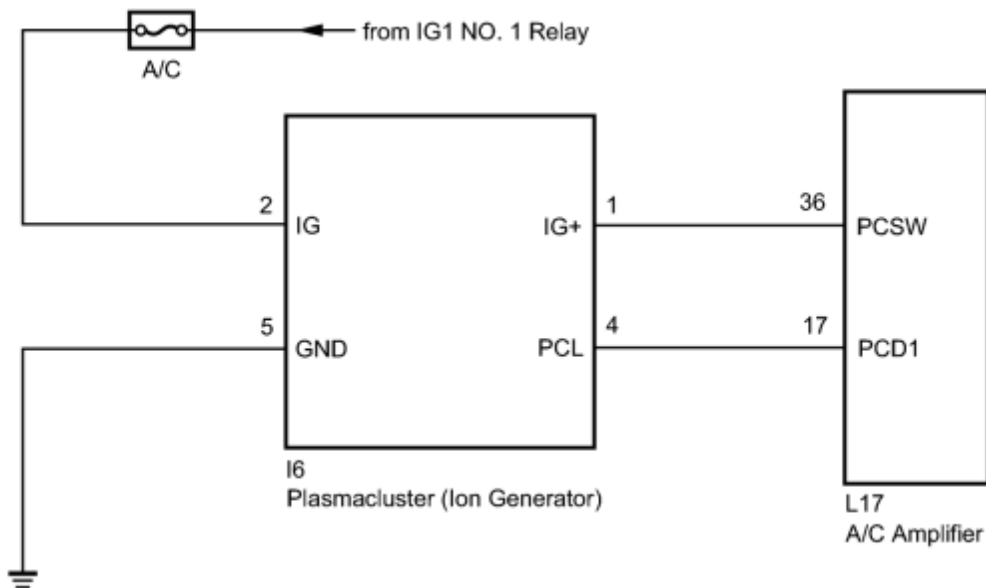

INSPECTION PROCEDURE

PROCEDURE

1. PERFORM ACTIVE TEST USING TECHSTREAM

(a) Connector the Techstream to the DLC3.

- (b) Turn the power switch on (IG).
- (c) Turn the Techstream on.
- (d) Enter the following menus: Body Electrical / Air Conditioner / Active Test.
- (e) Check the operation by referring to the table below.

Air Conditioner

Tester Display	Test Part	Control Range	Diagnostic Note
Air Purifier Mode	Plasmacluster (ion generator)	Stop, Ion, Clean	-

OK:

Plasmacluster (ion generator) operates and mode changes.

Result:

Result	Proceed to
NG	A
OK (When troubleshooting according to Problem Symptoms Table)	B
OK (When troubleshooting according to the DTC)	C

C ▶ REPLACE A/C AMPLIFIER

B ▶ PROCEED TO NEXT SUSPECTED AREA SHOWN IN PROBLEM SYMPTOMS TABLE

A



2.	CHECK HARNESS AND CONNECTOR (PLASMACLUSTER (ION GENERATOR) - BODY GROUND)
----	---

*1

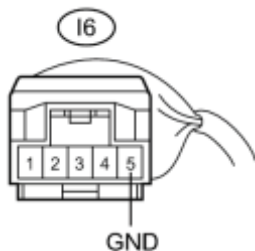

(a) Disconnect the plasmacluster (ion generator) connector.

H

(b) Measure the resistance according to the value(s) in the table below.

Standard Resistance:

Tester Connection	Condition	Specified Condition
I6-5 (GND) - Body ground	Always	Below 1 Ω

Text in Illustration

*1	Front view of wire harness connector (to Plasmacluster (Ion Generator))
----	--

NG ► REPAIR OR REPLACE HARNESS OR CONNECTOR

OK



3. CHECK HARNESS AND CONNECTOR (PLASMACLUSTER (ION GENERATOR) - BATTERY)

(a) Measure the voltage according to the value(s) in the table below.

*1

Standard Voltage:

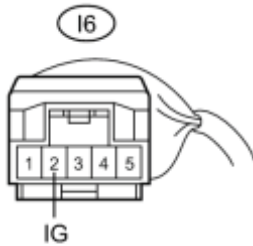

Tester Connection	Condition	Specified Condition
I6-2 (IG) - Body ground	Power switch off	Below 1 V
I6-2 (IG) - Body ground	Power switch on (IG)	11 to 14 V

Text in Illustration

*1	Front view of wire harness connector (to Plasmacluster (Ion Generator))
----	--

H

NG ► REPAIR OR REPLACE HARNESS OR CONNECTOR

OK



4. CHECK HARNESS AND CONNECTOR (PLASMACLUSTER (ION GENERATOR) - A/C AMPLIFIER)

(a) Disconnect the A/C amplifier connector.

*1

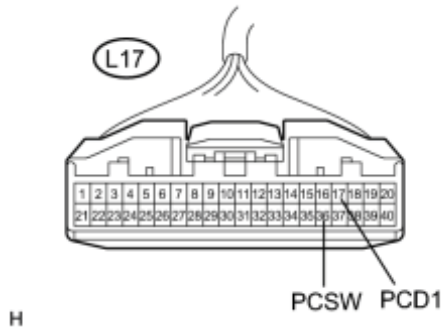

H

(b) Measure the resistance according to the value(s) in the table below.

Standard Resistance:

*2

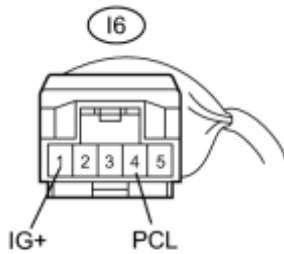

H

Tester Connection	Condition	Specified Condition
L17-17 (PCD1) - I6-4 (PCL)	Always	Below 1 Ω
L17-36 (PCSW) - I6-1 (IG+)	Always	Below 1 Ω
L17-17 (PCD1) - Body ground	Always	10 k Ω or higher
L17-36 (PCSW) - Body ground	Always	10 k Ω or higher

Text in Illustration

*1	Front view of wire harness connector (to A/C Amplifier)
*2	Front view of wire harness connector (to Plasmacluster (Ion Generator))

NG REPAIR OR REPLACE HARNESS OR CONNECTOR

OK

5. INSPECT PLASMACLUSTER (ION GENERATOR)

(a) Replace the plasmacluster (ion generator) INFO.

HINT:

Since the plasmacluster (ion generator) cannot be inspected while it is removed from the vehicle, replace the plasmacluster (ion generator) with a new or a known good one and check that the condition returns to normal.

(b) Check for the DTC.

Result:

Result	Proceed to
DTC B14A1 is output	A
DTC B14A1 is not output	B

B ▶ REPLACE PLASMACLUSTER (ION GENERATOR)

A ▶ REPLACE A/C AMPLIFIER

DESCRIPTION

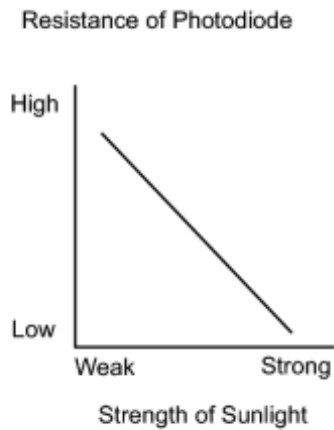

The solar sensor (automatic light control sensor) is installed on the upper side of the instrument panel. It detects sunlight to control air conditioning AUTO mode. The output voltage from the solar sensor (automatic light control sensor) varies in accordance with the amount of sunlight. When the amount of sunlight increases, the output voltage increases. As the sunlight decreases, the output voltage decreases. The A/C amplifier detects changes in the output voltage from the solar sensor (automatic light control sensor).

DTC No.	DTC Detection Condition	Trouble Area
B14A2	Short in driver side solar sensor circuit	<ul style="list-style-type: none"> • Solar sensor (automatic light control sensor) • Harness or connector between solar sensor (automatic light control sensor) and A/C amplifier • Harness or connector between solar sensor (automatic light control sensor) and main body ECU • Main body ECU • A/C amplifier

WIRING DIAGRAM

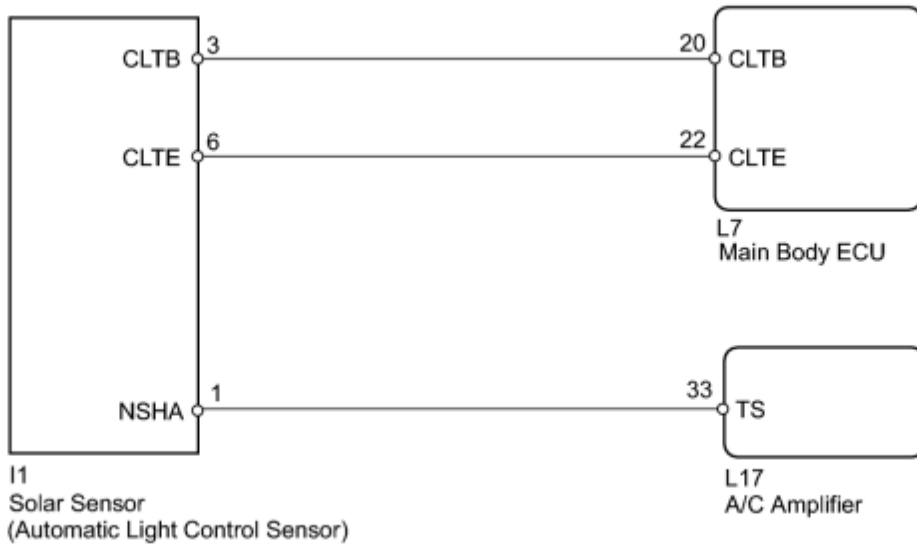

INSPECTION PROCEDURE

HINT:

If DTC B1244 is output together with other DTCs, troubleshoot DTC B1244 first INFO.

PROCEDURE

1. READ VALUE USING TECHSTREAM

- (a) Connect the Techstream to the DLC3.
- (b) Turn the power switch on (IG).
- (c) Turn the Techstream on.
- (d) Enter the following menus: Body Electrical / Air Conditioner / Data List.
- (e) Check the value(s) by referring to the table below.

Air Conditioner

Tester Display	Measurement Item/Range	Normal Condition	Diagnostic Note
Solar Sensor (D side)	Solar sensor / Min.: 0 Max.: 255	Solar sensor value increases as brightness increases	-

OK:

The display is as specified in the Normal Condition column.

Result:

Result	Proceed to
NG	A
OK (When troubleshooting according to Problem Symptoms Table)	B
OK (When troubleshooting according to the DTC)	C

C ▶ REPLACE A/C AMPLIFIER

B ▶ PROCEED TO NEXT SUSPECTED AREA SHOWN IN PROBLEM SYMPTOMS TABLE

A



2.	CHECK HARNESS AND CONNECTOR (POWER SOURCE CIRCUIT)
----	--

*1

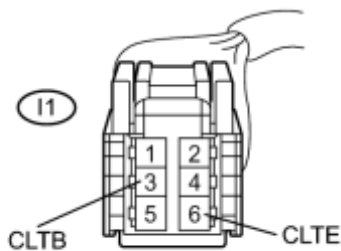

(a) Disconnect the solar sensor (automatic light control sensor) connector.

(b) Measure the voltage according to the value(s) in the table below.

Standard Voltage:

Tester Connection	Condition	Specified Condition
I1-3 (CLTB) - I1-6 (CLTE)	Power switch off	Below 1 V
I1-3 (CLTB) - I1-6 (CLTE)	Power switch on (IG)	11 to 14 V

Text in Illustration

*1	Front view of wire harness connector (to Solar Sensor (Automatic Light Control Sensor))
----	--

NG **CHECK HARNESS AND CONNECTOR (MAIN BODY ECU - SOLAR SENSOR)**

OK



3. **CHECK HARNESS AND CONNECTOR (SOLAR SENSOR - A/C AMPLIFIER)**

*1

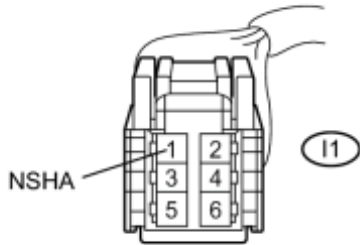

(a) Disconnect the solar sensor (automatic light control sensor) connector.

*2

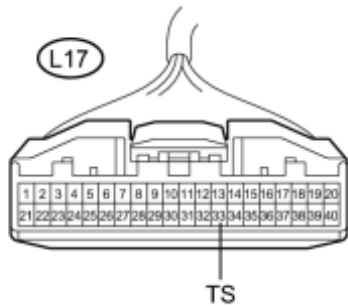

(b) Disconnect the A/C amplifier connector.

(c) Measure the resistance according to the value(s) in the table below.

Standard Resistance:

Tester Connection	Condition	Specified Condition
L17-33 (TS) - I1-1 (NSHA)	Always	Below 1 Ω
L17-33 (TS) - Body ground	Always	10 k Ω or higher

Text in Illustration

*1	Front view of wire harness connector
----	--------------------------------------

	(to Solar Sensor (Automatic Light Control Sensor))
*2	Front view of wire harness connector (to A/C Amplifier)

NG REPAIR OR REPLACE HARNESS OR CONNECTOR

OK



4.	INSPECT SOLAR SENSOR (AUTOMATIC LIGHT CONTROL SENSOR)
----	---

*1

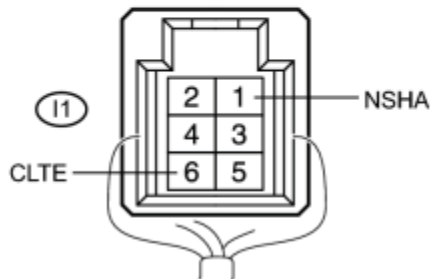

(a) Remove the solar sensor (automatic light control sensor).

(b) Reconnect the solar sensor (automatic light control sensor) connector.

(c) Turn the power switch on (IG).

(d) Measure the voltage according to the value(s) in the table below.

Standard Voltage:

Tester Connection	Condition	Specified Condition
I1-1 (NSHA) - I1-6 (CLTE)	Sensor is exposed to electric light	0.8 to 4.3 V
I1-1 (NSHA) - I1-6 (CLTE)	Sensor is covered with a cloth	Below 0.8 V

NOTICE:

- The connection procedure for using a digital tester such as a TOYOTA electrical tester is shown above. When using an analog tester, connect the negative (-) lead to terminal 3 and the positive (+) lead to terminal 6 of the solar sensor (automatic light control sensor).
- While using the battery during inspection, do not bring the positive and negative tester probes too close to each other as a short circuit may occur.

HINT:

- Use an incandescent light for inspection. Bring it within about 30 cm (11.8 in.) of the solar sensor (automatic light control sensor).
- As the inspection light is moved away from the sensor, the voltage decreases.

Text in Illustration

*1	Component with harness connected (Solar Sensor (Automatic Light Control Sensor))
----	---

NG ▶ REPLACE SOLAR SENSOR (AUTOMATIC LIGHT CONTROL SENSOR)

OK ▶ REPLACE A/C AMPLIFIER

5.	CHECK HARNESS AND CONNECTOR (MAIN BODY ECU - SOLAR SENSOR)
----	--

*1

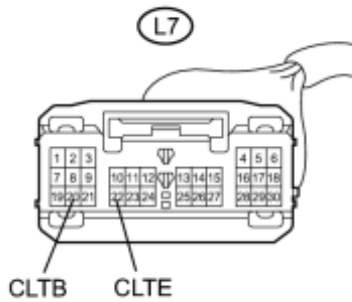

(a) Disconnect the main body ECU connector.

(b) Measure the resistance according to the value(s) in the table below.

Standard Resistance:

Tester Connection	Condition	Specified Condition
L7-20 (CLTB) - I1-3 (CLTB)	Always	Below 1 Ω
L7-22 (CLTE) - I1-6 (CLTE)	Always	Below 1 Ω
L7-20 (CLTB) - Body ground	Always	10 kΩ or higher
L7-22 (CLTE) - Body ground	Always	10 kΩ or higher

*2

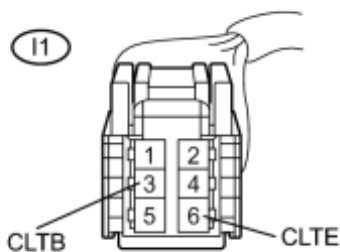

Text in Illustration

*1	Front view of wire harness connector (to Main Body ECU)
*2	Front view of wire harness connector (to Solar Sensor (Automatic Light Control Sensor))

NG  REPAIR OR REPLACE HARNESS OR CONNECTOR

OK  REPLACE MAIN BODY ECU

DTC	P0AA6-611	Hybrid Battery Voltage System Isolation Fault
-----	-----------	---

DESCRIPTION

The DTC is stored if there is insulation trouble with the high-voltage circuits in the air conditioning system. Possible causes are poor insulation in the compressor with motor assembly, or mixing of any oil other than ND-OIL 11 in the refrigerant cycle.

The motor driven with high-voltage is built into the electrical compressor and is cooled directly with refrigerant. Compressor oil (ND-OIL 11) with high insulation performance is used because a leakage of electrical power may occur if regular compressor oil (ND-OIL 8) is used.

CAUTION:

- Wear insulated gloves and pull out the service plug grip before inspection as procedures may require disconnecting high-voltage connectors.
- Be sure to carry the removed service plug grip because other workers may install it by mistake.
- Do not touch the high-voltage connectors or terminals for 10 minutes after the service plug grip is removed.

DTC No.	DTC Detection Condition	Trouble Area
P0AA6-611	High voltage system insulation malfunction	<ul style="list-style-type: none"> • Compressor oil • Refrigerant pipe line • Compressor with motor assembly • CAN communication system

WIRING DIAGRAM

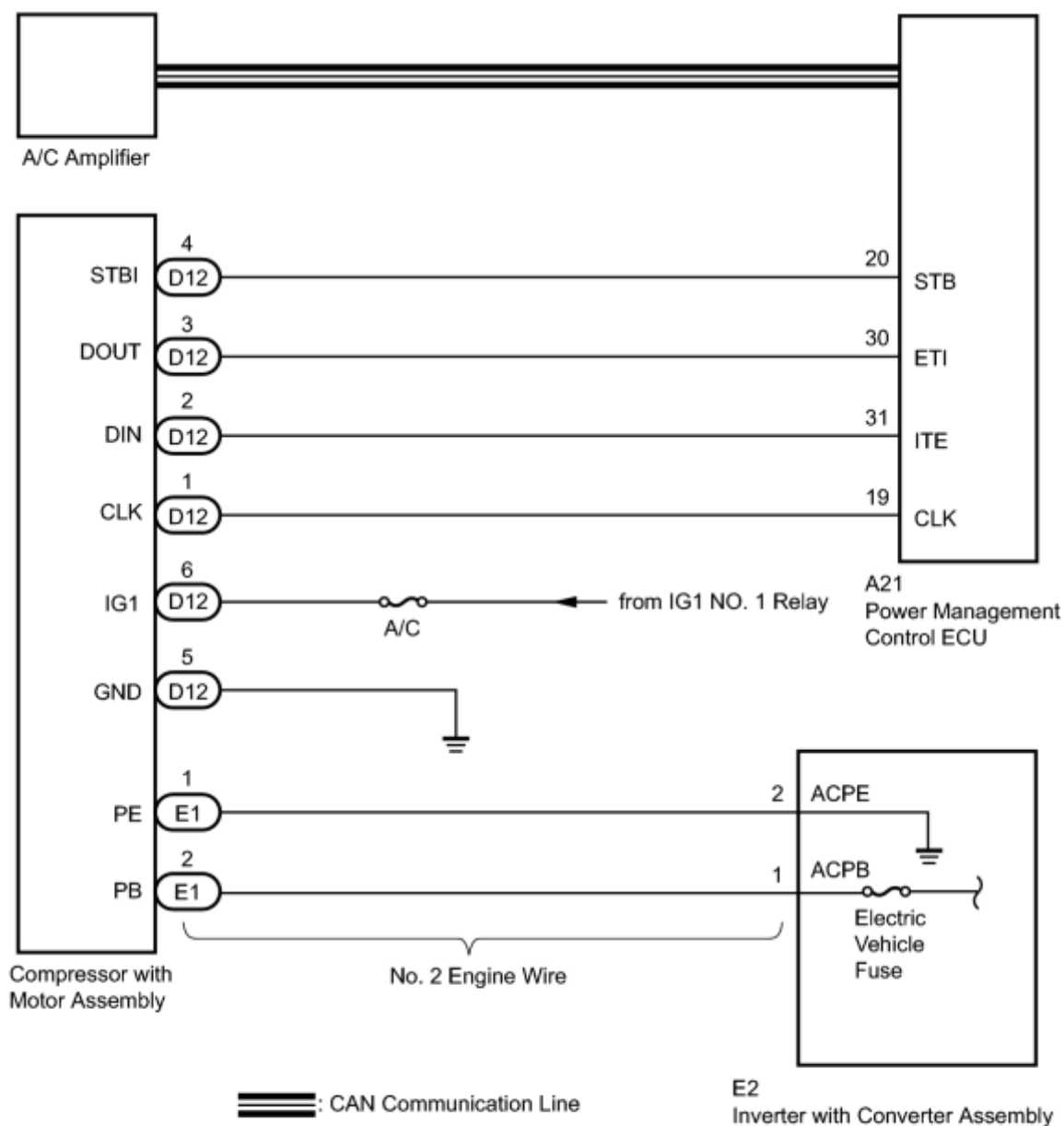

INSPECTION PROCEDURE

CAUTION:

- Wear insulated gloves and pull out the service plug grip before inspection as procedures may require disconnecting high-voltage connectors.
- Be sure to carry the removed service plug grip because other workers may install it by mistake.
- Do not touch the high-voltage connectors or terminals for 10 minutes after the service plug grip is removed.

NOTICE:

- Electrical insulation performance may decrease significantly if even a small amount of oil other than ND-OIL 11 is used (or enters) in the refrigerant cycle, causing the DTC to be output.
- If other oil is accidentally used and a DTC is output, collect the oil in the refrigerant cycle into the compressor and replace it with ND-OIL 11 to increase the ND-OIL 11 ratio amount.
- Replace the main components (evaporator, condenser, and compressor) if a large amount of oil other than ND-OIL 11 enters the system. Failing to do so may cause electrical insulation performance to remain low, causing the DTC to be output.
- The hybrid control system and air conditioning system output DTCs separately. Inspect DTCs following the flow chart for the hybrid control system first if any DTCs from those systems are output simultaneously.

HINT:

If it can be confirmed that any compressor oil other than ND-OIL 11 has been used in the vehicle, replace the air conditioning cycle.

PROCEDURE

1.	CHECK CAN COMMUNICATION SYSTEM
----	--------------------------------

(a) Using the Techstream to check if the CAN communication system is functioning normally.

Result:

Result	Proceed to
CAN DTC is not output	A
CAN DTC is output	B

B ▶ GO TO CAN COMMUNICATION SYSTEM

A



2.	INSPECT COMPRESSOR WITH MOTOR ASSEMBLY
----	--

CAUTION:

Because the compressor has a high-voltage circuit, wear insulated gloves and pull out the service plug grip to cut off the high-voltage circuit before inspection.

- (a) Clear the DTCs INFO.
- (b) Turn the power switch on (IG).
- (c) Prepare the vehicle according to the table below for 3 minutes.

Item	Condition
Blower speed	HI
Temperature setting	MAX COLD

Item	Condition
A/C	ON

(d) Turn the power switch off.

(e) Remove the service plug grip.

CAUTION:

Do not touch the high-voltage connectors or terminals for 10 minutes after the service plug grip is removed.

NOTICE:

Do not start the engine with the service plug grip removed because it may cause a malfunction.

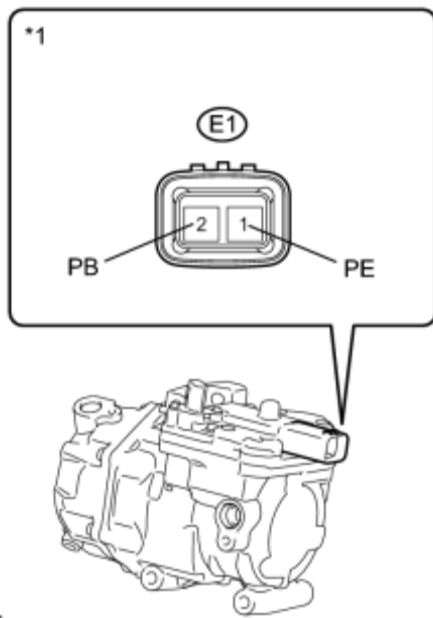

(f) Disconnect the connector from the compressor with motor assembly.

(g) Using a megohmmeter, measure the resistance according to the value(s) in the table below.

Standard Resistance:

Tester Connection	Condition	Specified Condition
E1-1 (PE) - Body ground	Always	2 MΩ or higher
E1-2 (PB) - Body ground	Always	2 MΩ or higher

Text in Illustration

*1	Component without harness connected (Compressor with Motor Assembly)
----	---

NG  REPLACE COMPRESSOR WITH MOTOR ASSEMBLY

OK



3.	INSPECT AIR CONDITIONING CYCLE
----	--------------------------------

CAUTION:

Because the compressor has a high-voltage circuit, wear insulated gloves and pull out the service plug grip to cut off the high-voltage circuit before inspection.

- (a) Reconnect the connector to the compressor with motor assembly.
- (b) Install the service plug grip.
- (c) Turn the power switch on (IG).
- (d) Set the A/C setting temperature to 25°C (77°F) and the blower switch LO and then operate the compressor for 10 minutes to circulate the refrigerant cycle with refrigerant and collect as much compressor oil as possible.
- (e) Turn the power switch off.
- (f) Using a spot cooler or other tools, cool down the compressor with motor assembly for 30 minutes, or leave the vehicle overnight before inspection.

NOTICE:

Do not operate the compressor before inspection.

- (g) Remove the service plug grip.

CAUTION:

Do not touch the high-voltage connectors or terminals for 10 minutes after the service plug grip is removed.

NOTICE:

Do not start the engine with the service plug grip removed because it may cause a malfunction.

- (h) Disconnect the connector from the compressor with motor assembly.

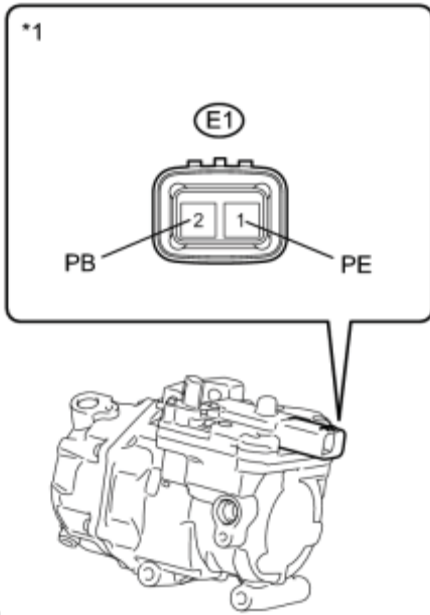

H

(i) Using a megohmmeter, measure the resistance according to the value(s) in the table below.

Standard Resistance:

Tester Connection	Condition	Specified Condition
E1-1 (PE) - Body ground	Always	3 MΩ or higher
E1-2 (PB) - Body ground	Always	3 MΩ or higher

NOTICE:

If the results are out of the specified range, replace the compressor without operating.

Text in Illustration

*1	Component without harness connected (Compressor with Motor Assembly)
----	---

NG ► REPLACE AIR CONDITIONING CYCLE

OK ► REPLACE COMPRESSOR WITH MOTOR ASSEMBLY

DTC	U0100	Lost Communication with ECM
DTC	U0101	Lost Communication with TCM
DTC	U0131	Lost Communication with Electric Power Steering ECU
DTC	U0142	Lost Communication with Main Body ECU
DTC	U0155	Lost Communication with Combination Meter
DTC	U0293	Lost Communication with HV ECU

DESCRIPTION

DTC No.	DTC Detecting Condition	Trouble Area
U0100	No communication with ECM	<ul style="list-style-type: none"> CAN communication system ECM
U0101	No communication with TCM	<ul style="list-style-type: none"> CAN communication system TCM
U0131	No communication with electric power steering ECU	<ul style="list-style-type: none"> CAN communication system Electric power steering ECU
U0142	No communication with main body ECU	<ul style="list-style-type: none"> CAN communication system Main body ECU
U0155	No communication with combination meter	<ul style="list-style-type: none"> CAN communication system Combination meter
U0293	No communication with HV ECU	<ul style="list-style-type: none"> CAN communication system Power management control ECU

INSPECTION PROCEDURE

PROCEDURE

1.	GO TO CAN COMMUNICATION SYSTEM
----	--------------------------------

HINT:

Refer to CAN Communication System .

NEXT  END

DESCRIPTION

This circuit consists of the A/C control assembly and A/C amplifier. When the A/C control assembly is operated, signals are transmitted to the A/C amplifier through the LIN communication system.

If the LIN communication system malfunctions, the A/C amplifier does not operate even if the A/C control assembly is operated.

WIRING DIAGRAM

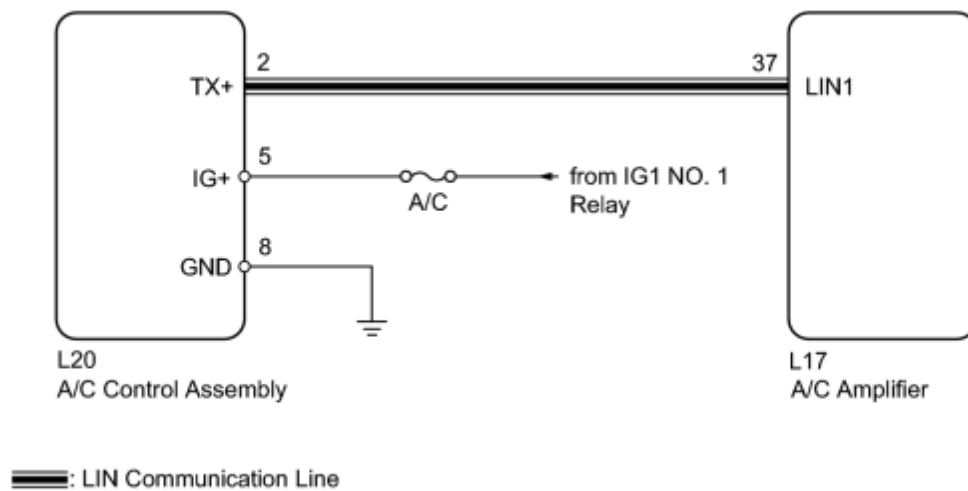

INSPECTION PROCEDURE

NOTICE:

Inspect the fuses for circuits related to this system before performing the following inspection procedure.

PROCEDURE

1. CHECK HARNESS AND CONNECTOR (A/C CONTROL ASSEMBLY - BODY GROUND)

- (a) Disconnect the A/C control assembly connector.
- (b) Measure the resistance according to the value(s) in the table below.

Standard Resistance:

*1

Tester Connection	Condition	Specified Condition
L20-8 (GND) - Body ground	Always	Below 1 Ω

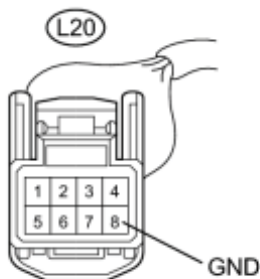

Text in Illustration

*1	Front view of wire harness connector (to A/C Control Assembly)
----	---

NG ► REPAIR OR REPLACE HARNESS OR CONNECTOR

OK



2. CHECK HARNESS AND CONNECTOR (A/C CONTROL ASSEMBLY - BATTERY)

(a) Measure the voltage according to the value(s) in the table below.

*1

Standard Voltage:

Tester Connection	Condition	Specified Condition
L20-5 (IG+) - L20-8 (GND)	Power switch on (IG)	11 to 14 V

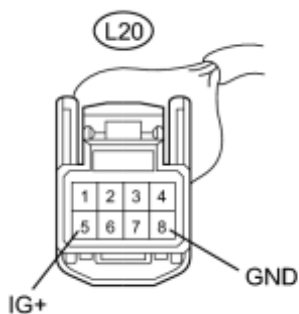

Text in Illustration

*1	Front view of wire harness connector (to A/C Control Assembly)
----	---

NG ► REPAIR OR REPLACE HARNESS OR CONNECTOR

OK



3. CHECK HARNESS AND CONNECTOR (A/C AMPLIFIER - A/C CONTROL ASSEMBLY)

(a) Disconnect the A/C amplifier connector.

*1

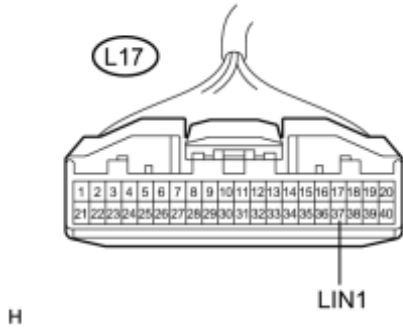

(b) Measure the resistance according to the value(s) in the table below.

Standard Resistance:

*2

Tester Connection	Condition	Specified Condition
L17-37 (LIN1) - L20-2 (TX+)	Always	Below 1 Ω
L17-37 (LIN1) - Body ground	Always	10 k Ω or higher

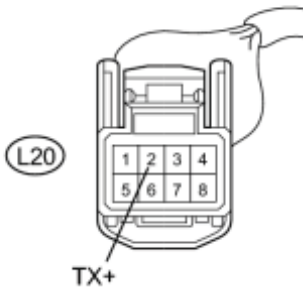

Text in Illustration

*1	Front view of wire harness connector (to A/C Amplifier)
*2	Front view of wire harness connector (to A/C Control Assembly)

NG ► REPAIR OR REPLACE HARNESS OR CONNECTOR

OK



4. REPLACE A/C CONTROL ASSEMBLY

(a) Replace the A/C control assembly with a known good one and check if the same problem occurs again INFO

OK:

Same problem does not occur.

NG ► PROCEED TO NEXT SUSPECTED AREA SHOWN IN PROBLEM SYMPTOMS TABLE

OK  **END (A/C CONTROL ASSEMBLY WAS DEFECTIVE)**

DESCRIPTION

The blower motor is operated by signals from the A/C amplifier. Blower motor speed signals are transmitted in accordance with changes in the duty ratio.

WIRING DIAGRAM

1. w/o Solar Ventilation System

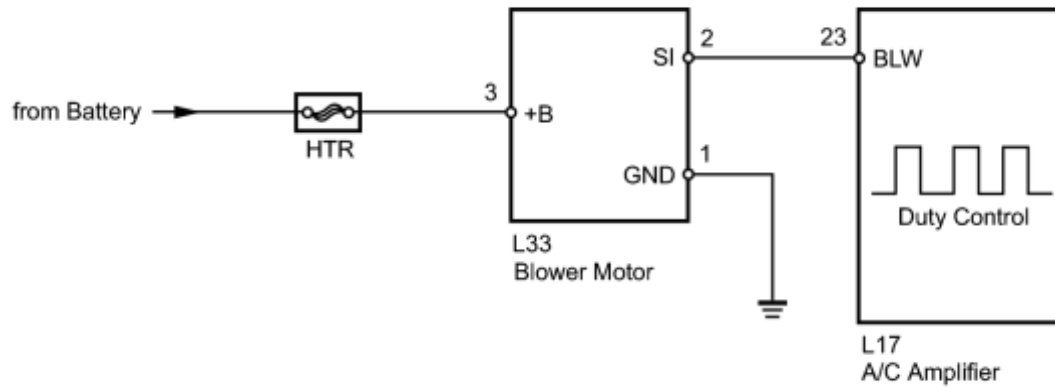

2. w/ Solar Ventilation System

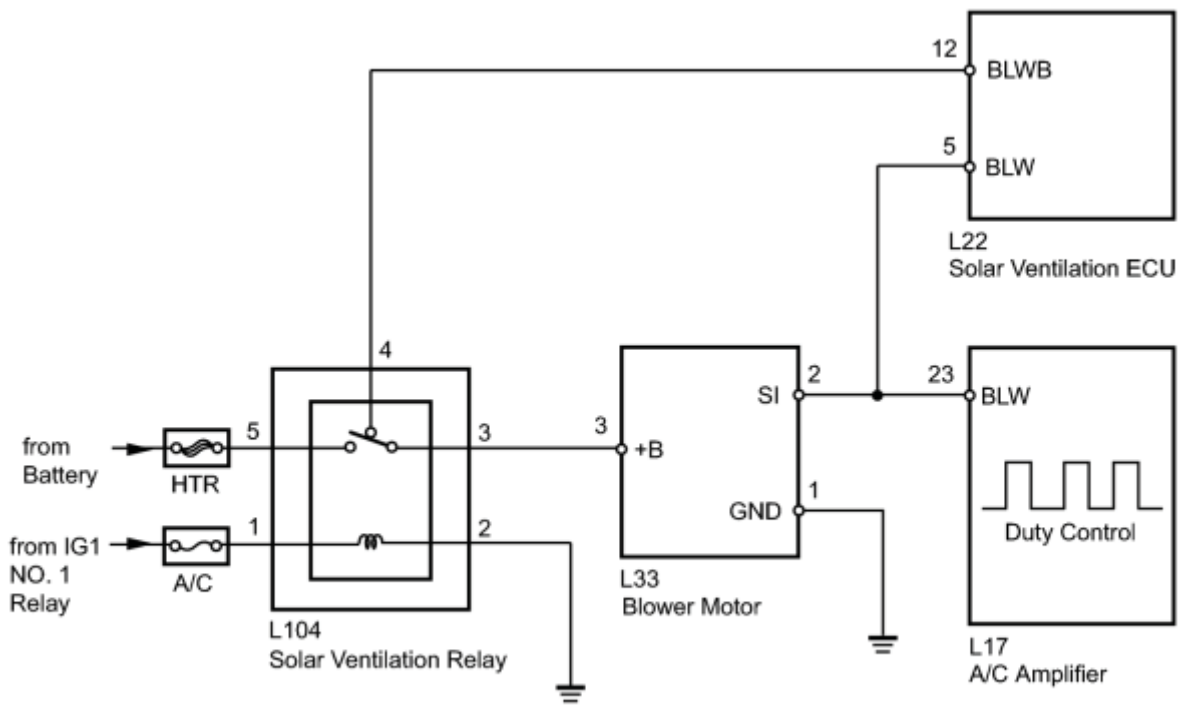

INSPECTION PROCEDURE

NOTICE:

Inspect the fuses for circuits related to this system before performing the following inspection procedure.

PROCEDURE

1. PERFORM ACTIVE TEST USING TECHSTREAM

- Connect the Techstream to the DLC3.
- Turn the power switch on (IG).
- Turn the Techstream on.
- Enter the following menus: Body Electrical / Air Conditioner / Active Test.
- Check the operation by referring to the table below.

Air Conditioner

Tester Display	Test Part	Control Range	Diagnostic Note
Blower Motor	Blower motor	Min.: 0, Max.: 31	-

OK:

Blower motor operates and blower motor speed level changes.

Result:

Result	Proceed to
OK	A
NG (Blower motor does not operate) (w/o Solar ventilation system)	B
NG (Blower motor does not operate) (w/ Solar ventilation system)	C
NG (Blower motor operates but does not change speed) (w/o Solar ventilation system)	D
NG (Blower motor operates but does not change speed) (w/ Solar ventilation system)	E

E ▶ [CHECK HARNESS AND CONNECTOR \(BLOWER MOTOR - A/C AMPLIFIER, SOLAR VENTILATION ECU\)](#)

D ▶ [INSPECT A/C AMPLIFIER](#)

C ▶ [INSPECT SOLAR VENTILATION RELAY](#)

B ▶ [CHECK HARNESS AND CONNECTOR \(BLOWER MOTOR - BODY GROUND\)](#)

A ▶ **PROCEED TO NEXT SUSPECTED AREA SHOWN IN PROBLEM SYMPTOMS TABLE**

2.	CHECK HARNESS AND CONNECTOR (BLOWER MOTOR - BODY GROUND)
----	--

*1

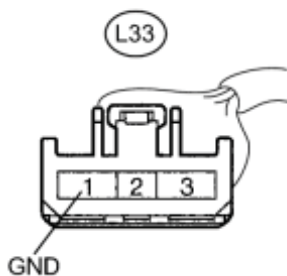

(a) Disconnect the blower motor connector.

(b) Measure the resistance according to the value(s) in the table below.

Standard Resistance:

Tester Connection	Condition	Specified Condition
L33-1 (GND) - Body ground	Always	Below 1 Ω

Text in Illustration

*1	Front view of wire harness connector (to Blower Motor)
----	---

NG REPAIR OR REPLACE HARNESS OR CONNECTOR

OK



3.	CHECK HARNESS AND CONNECTOR (BLOWER MOTOR - BATTERY)
----	--

(a) Measure the voltage according to the value(s) in the table below.

*1

Standard Voltage:

Tester Connection	Condition	Specified Condition
L33-3 (+B) - Body ground	Power switch off	11 to 14 V

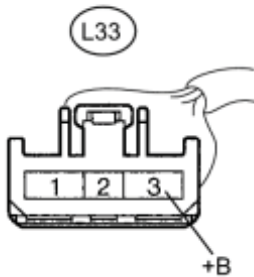

Text in Illustration

*1	Front view of wire harness connector (to Blower Motor)
----	---

NG REPAIR OR REPLACE HARNESS OR CONNECTOR

OK



4.	CHECK HARNESS AND CONNECTOR (BLOWER MOTOR - A/C AMPLIFIER)
----	--

(a) Disconnect the A/C amplifier connector.

*1

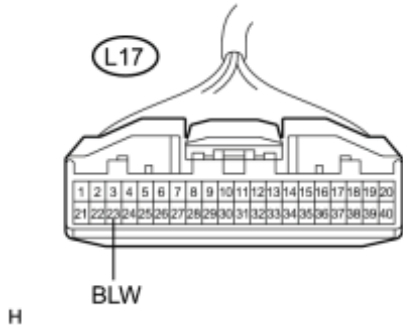

(b) Measure the resistance according to the value(s) in the table below.

Standard Resistance:

*3

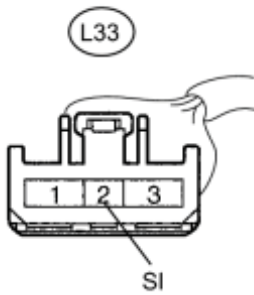

Tester Connection	Condition	Specified Condition
L17-23 (BLW) - L33-2 (SI)	Always	Below 1 Ω
L17-23 (BLW) - Body ground	Always	10 kΩ or higher

Text in Illustration

*1	Front view of wire harness connector (to A/C Amplifier)
*2	Front view of wire harness connector (to Blower Motor)

NG REPAIR OR REPLACE HARNESS OR CONNECTOR

OK

5. INSPECT BLOWER MOTOR

(a) Reconnect the blower motor connector.

(b) Measure the voltage according to the value(s) in the table below.

Standard Voltage:

Tester Connection	Condition	Specified Condition
L17-23 (BLW) - Body ground	Power switch off	4.5 to 5.5 V

*1

Text in Illustration

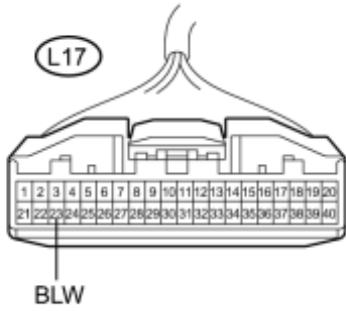

*1	Front view of wire harness connector (to A/C Amplifier)
----	--

NG ▶ REPLACE BLOWER MOTOR

OK



6.	INSPECT A/C AMPLIFIER
----	-----------------------

*1

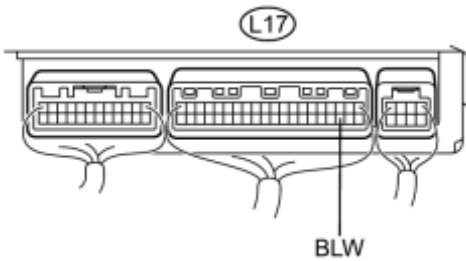

(a) Remove the A/C amplifier.

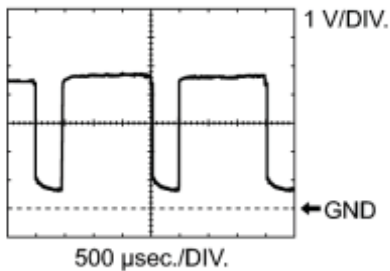

(b) Reconnect the A/C amplifier connector.

(c) Turn the power switch on (IG).

(d) Set the blower speed to LO.

(e) Measure the waveform between terminal L17-23 (BLW) of the A/C amplifier and body ground.

Item	Content
Tool setting	1 V/DIV., 500 μ s/DIV.
Vehicle condition	Power switch on (IG) Blower set to LO

OK:

Waveform is as shown in the illustration.

HINT:

The waveform varies with the blower speed.

Text in Illustration

*1	Component with harness connected (A/C Amplifier)
----	---

NG ► REPLACE A/C AMPLIFIER

OK ► REPLACE BLOWER MOTOR

7.	INSPECT SOLAR VENTILATION RELAY
----	---------------------------------

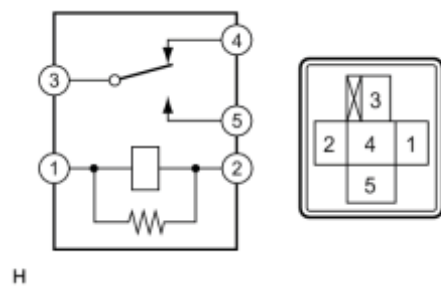

(a) Remove the solar ventilation relay from the relay block No. 2-1.

(b) Measure the resistance according to the value(s) in the table below.

Standard Resistance:

Tester Connection	Specified Condition
3 - 5	10 k Ω or higher
3 - 4	Below 1 Ω
3 - 5	Below 1 Ω (when battery voltage is applied to terminals 1 and 2)

Tester Connection	Specified Condition
3 - 4	10 kΩ or higher (when battery voltage is applied to terminals 1 and 2)

NG ▶ REPLACE SOLAR VENTILATION RELAY

OK



8.	CHECK HARNESS AND CONNECTOR (SOLAR VENTILATION RELAY - BATTERY)
----	---

*1

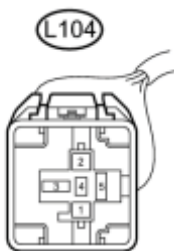

(a) Disconnect the solar ventilation relay connector.

H

(b) Measure the voltage according to the value(s) in the table below.

Standard Voltage:

Tester Connection	Condition	Specified Condition
L104-1 - Body ground	Power switch off	Below 1 V
L104-1 - Body ground	Power switch on (IG)	11 to 14 V
L104-5 - Body ground	Always	11 to 14 V

Text in Illustration

*1	Front view of wire harness connector (to Solar Ventilation Relay)
----	--

NG ▶ REPAIR OR REPLACE HARNESS OR CONNECTOR

OK



9.	CHECK HARNESS AND CONNECTOR (SOLAR VENTILATION RELAY - BODY GROUND)
----	---

*1

(a) Measure the resistance according to the value(s) in the table below.

Standard Resistance:

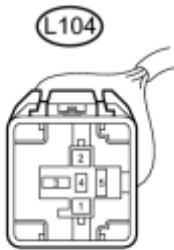

Tester Connection	Condition	Specified Condition
L104-2 - Body ground	Always	Below 1 Ω

Text in Illustration

*1	Front view of wire harness connector (to Solar Ventilation Relay)
----	--

H

NG REPAIR OR REPLACE HARNESS OR CONNECTOR

OK



10.	CHECK HARNESS AND CONNECTOR (BLOWER MOTOR - BODY GROUND)
-----	--

*1

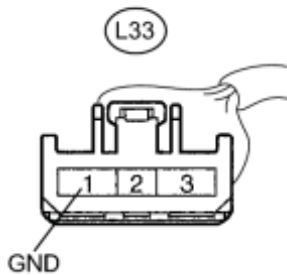

(a) Disconnect the blower motor connector.

(b) Measure the resistance according to the value(s) in the table below.

Standard Resistance:

Tester Connection	Condition	Specified Condition
L33-1 (GND) - Body ground	Always	Below 1 Ω

Text in Illustration

*1	Front view of wire harness connector (to Blower Motor)
----	---

NG REPAIR OR REPLACE HARNESS OR CONNECTOR

OK



11. CHECK HARNESS AND CONNECTOR (BLOWER MOTOR - BATTERY)

(a) Reinstall the solar ventilation relay.

(b) Reconnect the solar ventilation relay connector.

(c) Measure the voltage according to the value(s) in the table below.

Standard Voltage:

*1

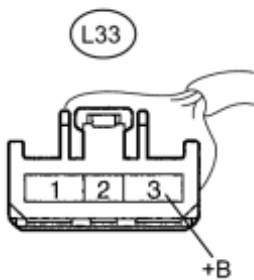

Tester Connection	Condition	Specified Condition
L33-3 (+B) - Body ground	Power switch off Solar ventilation switch off	Below 1 V
L33-3 (+B) - Body ground	Power switch on (IG)	11 to 14 V

Text in Illustration

*1	Front view of wire harness connector (to Blower Motor)
----	---

NG REPAIR OR REPLACE HARNESS OR CONNECTOR (BLOWER MOTOR - RELAY BLOCK NO. 2-1)

OK



12. CHECK HARNESS AND CONNECTOR (BLOWER MOTOR - A/C AMPLIFIER, SOLAR VENTILATION ECU)

(a) Disconnect the A/C amplifier connector.

*1

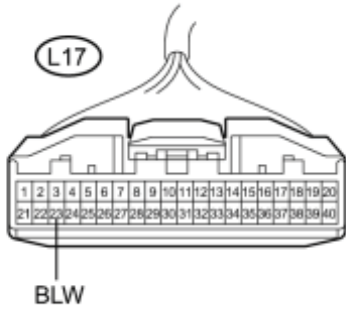

H

*2

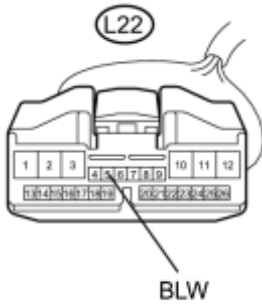

H

(b) Disconnect the solar ventilation ECU connector.

(c) Measure the resistance according to the value(s) in the table below.

Standard Resistance:

Tester Connection	Condition	Specified Condition
L17-23 (BLW) - L33-2 (SI)	Always	Below 1 Ω
L22-5 (BLW) - L33-2 (SI)	Always	Below 1 Ω
L17-23 (BLW) - Body ground	Always	10 k Ω or higher
L22-5 (BLW) - Body ground	Always	10 k Ω or higher

*3

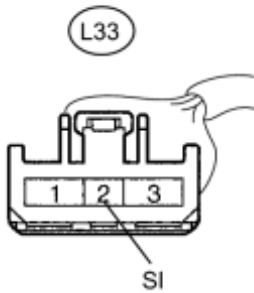

Text in Illustration

*1	Front view of wire harness connector (to A/C Amplifier)
*2	Front view of wire harness connector (to Solar Ventilation ECU)

*3	Front view of wire harness connector (to Blower Motor)
----	---

NG ▶ REPAIR OR REPLACE HARNESS OR CONNECTOR

OK



13.	INSPECT BLOWER MOTOR
-----	----------------------

(a) Reconnect the blower motor connector.

(b) Measure the voltage according to the value(s) in the table below.

Standard Voltage:

*1

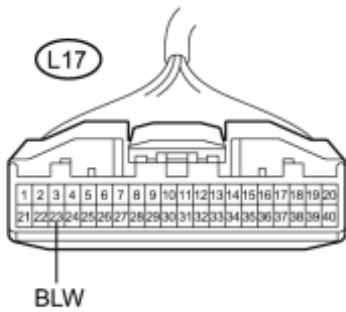

Tester Connection	Condition	Specified Condition
L17-23 (BLW) - Body ground	Power switch off Solar ventilation switch off	Below 1 V
L17-23 (BLW) - Body ground	Power switch on (IG)	4.5 to 5.5 V

Text in Illustration

*1	Front view of wire harness connector (to A/C Amplifier)
----	--

NG ▶ REPLACE BLOWER MOTOR

OK



14.	INSPECT A/C AMPLIFIER
-----	-----------------------

(a) Remove the A/C amplifier.

*1

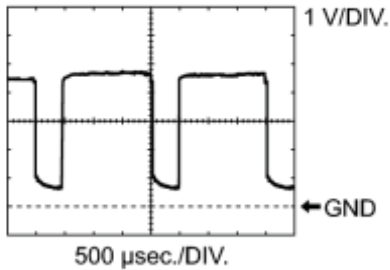
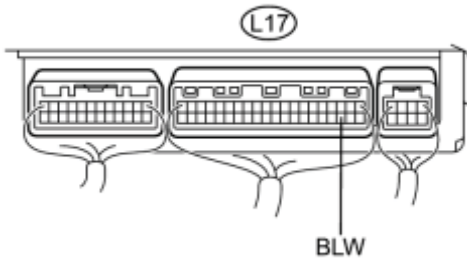

- (b) Reconnect the A/C amplifier connector.
- (c) Turn the power switch on (IG).
- (d) Set the blower speed to LO.
- (e) Measure the waveform between terminal L17-23 (BLW) of the A/C amplifier and body ground.

Item	Content
Tool setting	1 V/DIV., 500 μs/DIV.
Vehicle condition	Power switch on (IG) Blower set to LO

OK:

Waveform is as shown in the illustration.

HINT:

The waveform varies with the blower speed.

Text in Illustration

*1	Component with harness connected
----	----------------------------------

(A/C Amplifier)

NG ▶ REPLACE A/C AMPLIFIER

OK ▶ REPLACE BLOWER MOTOR

DESCRIPTION

The PTC heater assembly is installed in the radiator in the heater unit and operates when engine coolant temperature is low and normal heater effectiveness is insufficient.

The A/C control assembly switches the circuit in the PTC relay and operates the PTC heater assembly when the operating conditions (cooling water temperature is below 65°C (149°F), setting temperature is MAX. HOT, ambient temperature is below 10°C (50°F) and blower switch is not OFF) are met.

The PTC heater assembly controls PTC heater lines by electric load or the amount of inverter with converter assembly (PCU) output. Therefore, troubleshooting should be performed with other electric components off.

WIRING DIAGRAM

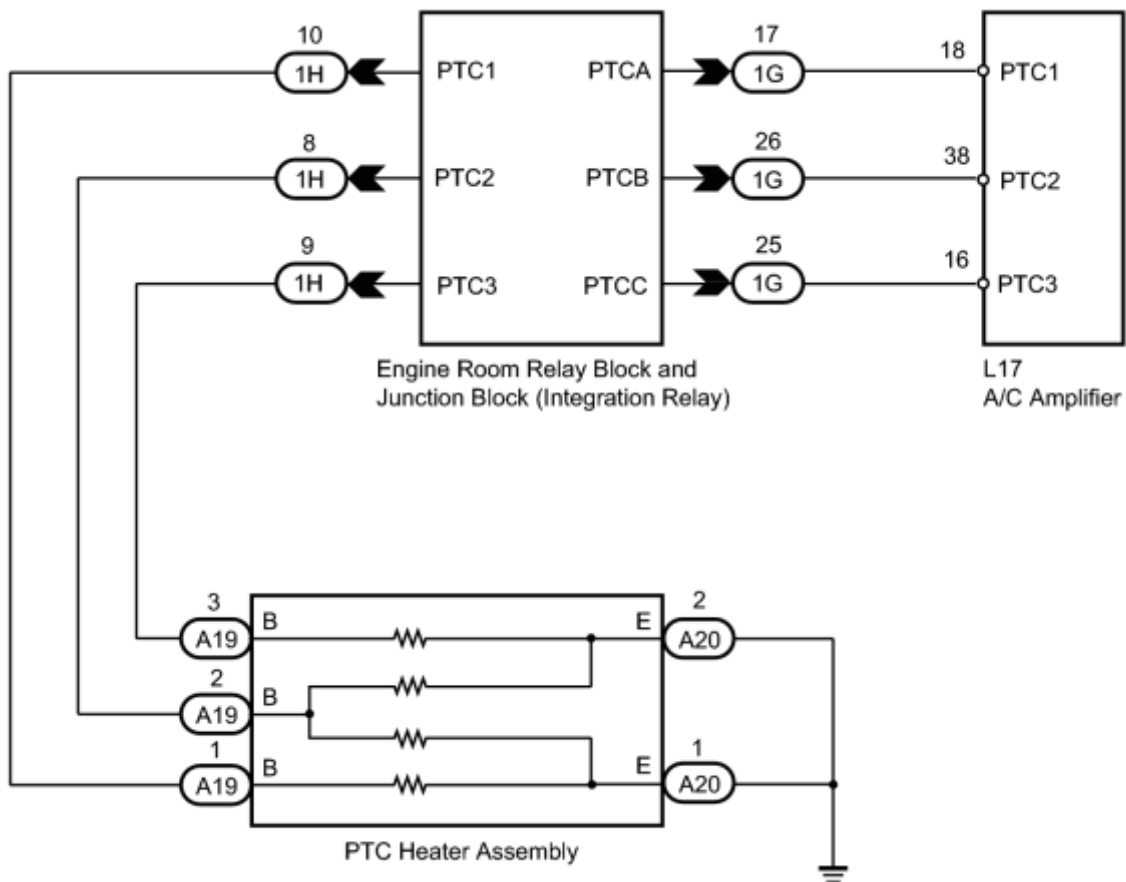

INSPECTION PROCEDURE

PROCEDURE

1. INSPECT PTC HEATER ASSEMBLY

*1



(a) Remove the PTC heater assembly.



(b) Measure the resistance according to the value(s) in the table below.

Standard Resistance:

Tester Connection	Condition	Specified Condition
A19-1 (B) - A20-1 (E)	Always	Below 1 Ω
A19-2 (B) - A20-2 (E)	Always	Below 1 Ω
A19-2 (B) - A20-1 (E)	Always	Below 1 Ω
A19-3 (B) - A20-2 (E)	Always	Below 1 Ω

Text in Illustration

*1	Component without harness connected (PTC Heater Assembly)
----	--

NG REPLACE PTC HEATER ASSEMBLY

OK



2. CHECK HARNESS AND CONNECTOR (PTC HEATER ASSEMBLY - BODY GROUND)

(a) Measure the resistance according to the value(s) in the table below.

Standard Resistance:

Tester Connection	Condition	Specified Condition
-------------------	-----------	---------------------

*1

A20-1 (E) - Body ground	Always	Below 1 Ω
A20-2 (E) - Body ground	Always	Below 1 Ω

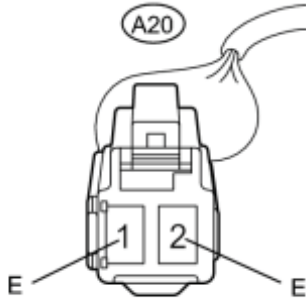

Text in Illustration

*1	Front view of wire harness connector (to PTC Heater Assembly)
----	--

H

NG REPAIR OR REPLACE HARNESS OR CONNECTOR

OK



3. CHECK HARNESS AND CONNECTOR (PTC HEATER ASSEMBLY - INTEGRATION RELAY)

*1

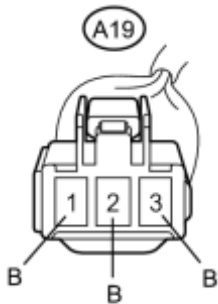

H

(a) Disconnect the PTC heater assembly connector.

(b) Disconnect the engine room relay block and junction block (integration relay) connector.

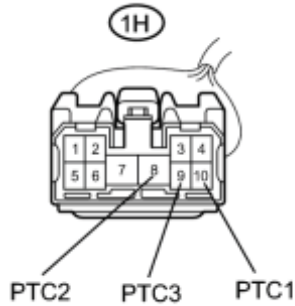

H

(c) Measure the resistance according to the value(s) in the table below.

Standard Resistance:

Tester Connection	Condition	Specified Condition
A19-1 (B) - 1H-10 (PTC1)	Always	Below 1 Ω
A19-2 (B) - 1H-8 (PTC2)	Always	Below 1 Ω
A19-3 (B) - 1H-9 (PTC3)	Always	Below 1 Ω
A19-1 (B) - Body ground	Always	10 k Ω or higher
A19-2 (B) - Body ground	Always	10 k Ω or higher
A19-3 (B) - Body ground	Always	10 k Ω or higher

Text in Illustration

*1	Front view of wire harness connector (to PTC Heater Assembly)
*2	Front view of wire harness connector (to Engine Room Relay Block and Junction Block (Integration Relay))

NG ► REPAIR OR REPLACE HARNESS OR CONNECTOR

OK



4.	CHECK HARNESS AND CONNECTOR (A/C AMPLIFIER - INTEGRATION RELAY)
----	---

(a) Disconnect the A/C amplifier connector.

*1

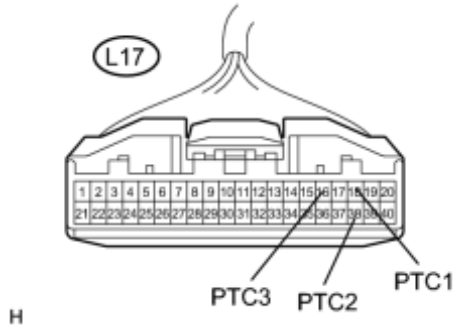

H

*2

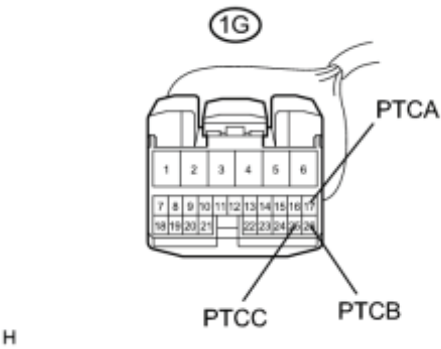

H

(b) Disconnect the engine room relay block and junction block (integration relay) connector.

(c) Measure the resistance according to the value(s) in the table below.

Standard Resistance:

Tester Connection	Condition	Specified Condition
L17-18 (PTC1) - 1G-17 (PTCA)	Always	Below 1 Ω
L17-38 (PTC2) - 1G-26 (PTCB)	Always	Below 1 Ω
L17-16 (PTC3) - 1G-25 (PTCC)	Always	Below 1 Ω
L17-18 (PTC1) - Body ground	Always	10 kΩ or higher
L17-38 (PTC2) - Body ground	Always	10 kΩ or higher
L17-16 (PTC3) - Body ground	Always	10 kΩ or higher

Text in Illustration

*1	Front view of wire harness connector (to A/C Amplifier)
*2	Front view of wire harness connector

(to Engine Room Relay Block and Junction Block (Integration Relay))

NG ▶ REPAIR OR REPLACE HARNESS OR CONNECTOR

OK



5. REPLACE INTEGRATION NO.1 RELAY

(a) Replace the integration relay **INFO**.

HINT:

Since the integration relay cannot be inspected while it is removed from the vehicle, replace the integration relay with a new or a known good one and check that the condition returns to normal.

(b) Check if the same problem occurs again.

OK:

Same problem does not occur.

NG ▶ PROCEED TO NEXT SUSPECTED AREA SHOWN IN PROBLEM SYMPTOMS TABLE

OK ▶ END (INTEGRATION RELAY WAS DEFECTIVE)

DESCRIPTION

The R/F, TEMP UP (+), and TEMP DOWN (-) switches are located on the steering pad switch assembly. The resistance of the steering pad switch assembly changes in accordance with switch operation. The A/C control assembly outputs voltage to the steering pad switch assembly and reads voltage changes due to the resistance changes that result from switch operation.

HINT:

If there is an open in the circuit, the A/C system cannot be operated by the steering pad switch assembly.

If there is a short in the circuit, the resulting condition is the same as if the switch were continuously depressed. Therefore, the A/C control assembly cannot be operated by the steering pad switch assembly, and the A/C control assembly will not be able to function correctly.

WIRING DIAGRAM

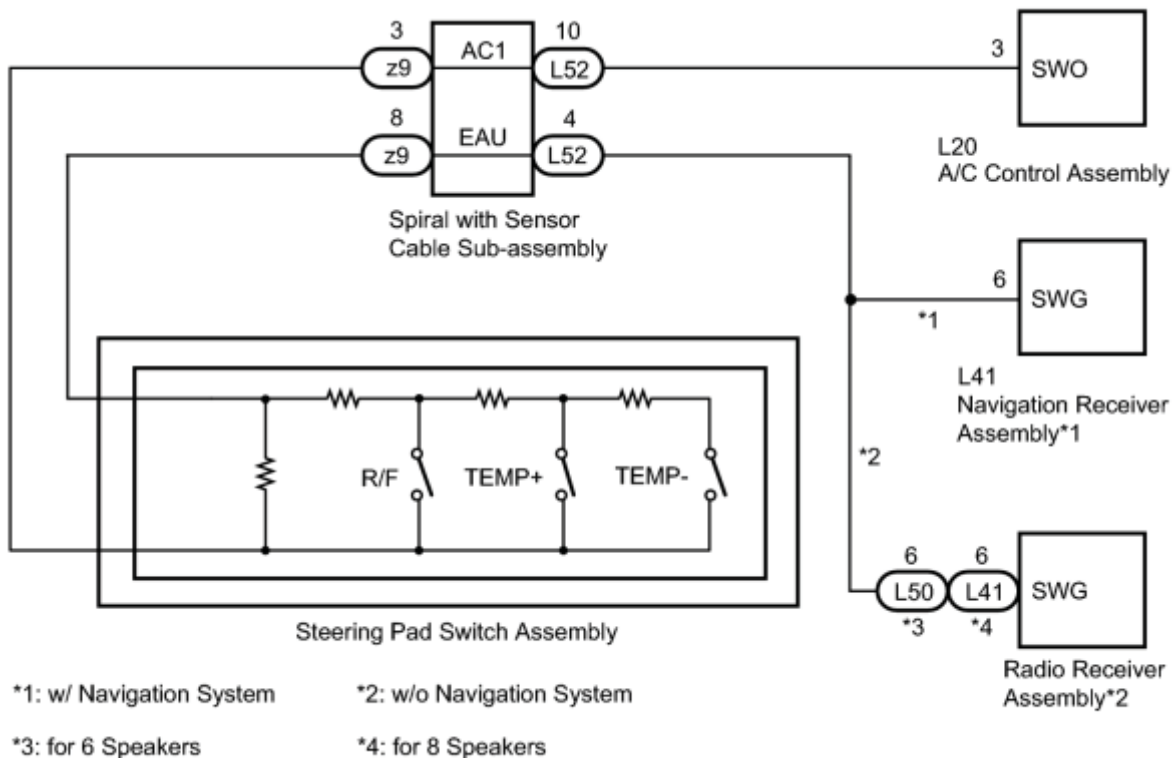

INSPECTION PROCEDURE

NOTICE:

The vehicle is equipped with an SRS (Supplemental Restraint System). Before servicing (including removal or installation of parts), be sure to read the precaution for Supplemental Restraint System INFO.

PROCEDURE

1. INSPECT A/C CONTROL ASSEMBLY

*1



(a) Disconnect the connector from the spiral with sensor cable sub-assembly.

H

(b) Measure the voltage according to the value(s) in the table below.

Standard Voltage:

Tester Connection	Condition	Specified Condition
L52-10 (AC1) - Body ground	Power switch off	Below 1 V
L52-10 (AC1) - Body ground	Power switch on (IG)	4.5 to 5.5 V

Text in Illustration

*1	Front view of wire harness connector (to Spiral with Sensor Cable Sub-assembly)
----	--

NG [▶ CHECK HARNESS AND CONNECTOR \(A/C CONTROL ASSEMBLY - SPIRAL WITH SENSOR CABLE SUB-ASSEMBLY\)](#)

OK



2. CHECK HARNESS AND CONNECTOR

(a) Disconnect the connector from the navigation receiver assembly*4 or radio receiver assembly*5.

*1

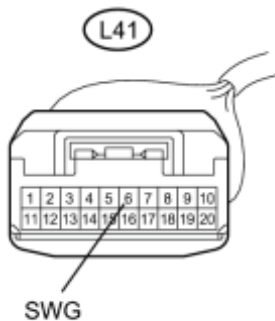

H

*2



H

(b) Disconnect the connector from the radio receiver assembly*6.

(c) Measure the resistance according value(s) in the table below.

Standard Resistance:

*3



H

Tester Connection	Condition	Specified Condition
L41-6 (SWG) - L52-4 (EAU)*4, *5	Always	Below 1 Ω
L50-6 (SWG) - L52-4 (EAU)*6	Always	Below 1 Ω
L41-6 (SWG) - Body ground*4, *5	Always	10 k Ω or higher
L50-6 (SWG) - Body ground*6	Always	10 k Ω or higher

Text in Illustration

*1	Front view of wire harness connector (to Navigation Receiver Assembly*4, Radio Receiver Assembly*5)
*2	Front view of wire harness connector (to Radio Receiver Assembly*6)

*3	Front view of wire harness connector (to Spiral with Sensor Cable Sub-assembly)
----	--

*4: w/ Navigation System

*5: w/o Navigation System (for 8 Speakers)

*6: w/o Navigation System (for 6 Speakers)

NG ► REPAIR OR REPLACE HARNESS OR CONNECTOR

OK



3.	INSPECT STEERING PAD SWITCH ASSEMBLY
----	--------------------------------------

(a) Disconnect the connector from the steering pad switch assembly.

*1

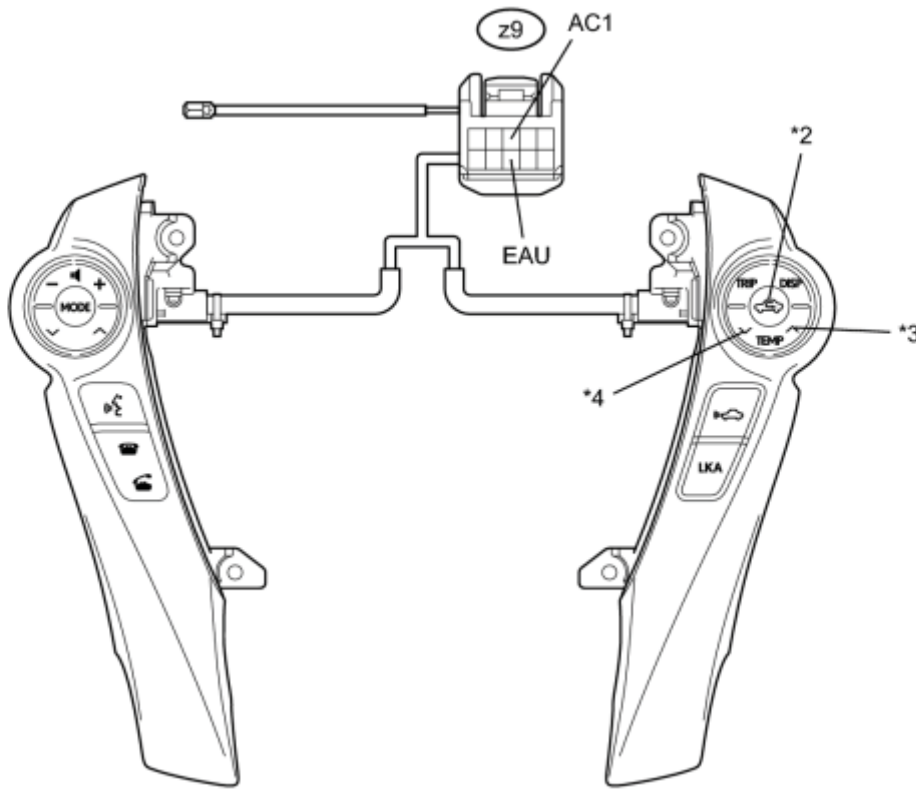

H

(b) Measure the resistance according to the value(s) in the table below.

Standard Resistance:

Tester Connection	Condition	Specified Condition
-------------------	-----------	---------------------

Tester Connection	Condition	Specified Condition
z9-3 (AC1) - z9-8 (EAU)	No switch pushed	95 to 105 k Ω
z9-3 (AC1) - z9-8 (EAU)	R/F switch pushed	323 to 335 Ω
z9-3 (AC1) - z9-8 (EAU)	TEMP+ switch pushed	980 to 1020 Ω
z9-3 (AC1) - z9-8 (EAU)	TEMP- switch pushed	3048 to 3172 Ω

Text in Illustration

*1	Component without harness connected (Steering Pad Switch Assembly)	*2	R/F Switch
*3	TEMP+ Switch	*4	TEMP- Switch

NG  REPLACE STEERING PAD SWITCH ASSEMBLY

OK



4.	INSPECT SPIRAL WITH SENSOR CABLE SUB-ASSEMBLY
----	---

*1

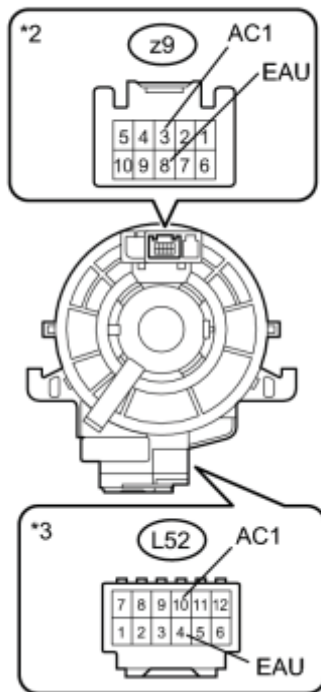

(a) Disconnect the connector from the spiral with sensor cable sub-assembly.

H

(b) Measure the resistance according to the value(s) in the table below.

Standard Resistance:



Tester Connection	Condition	Specified Condition
-------------------	-----------	---------------------

Tester Connection	Condition	Specified Condition
L52-10 (AC1) - z9-3 (AC1)	Center	Below 1 Ω
	2.5 rotations to the left	
	2.5 rotations to the right	
L52-4 (EAU) - z9-8 (EAU)	Center	Below 1 Ω
	2.5 rotations to the left	
	2.5 rotations to the right	

NOTICE:

The spiral with sensor cable sub-assembly is an important part of the SRS airbag system. Incorrect removal or installation of the spiral with sensor cable sub-assembly may prevent the airbag from deploying. Refer to the pages shown in the brackets.

HINT:

- Removal 
- Installation 
- The spiral cable makes a maximum of approximately 5 rotations.

Text in Illustration

*1	Component without harness connected (Spiral with Sensor Cable Sub-assembly)
*2	Steering Pad Switch Side
*3	Vehicle Side

NG  REPLACE SPIRAL WITH SENSOR CABLE SUB-ASSEMBLY

OK



5.	CONFIRM MODEL
----	---------------

Result:

Result	Proceed to
w/ Navigation System	A
w/o Navigation System	B

B  [REPLACE RADIO RECEIVER ASSEMBLY](#)

A



6.	REPLACE NAVIGATION RECEIVER ASSEMBLY
----	--------------------------------------

(a) Re **INFO** the navigation receiver assembly with a known good one and check if the same problem occurs again .

OK:

Same problem does not occur.

NG ► PROCEED TO NEXT SUSPECTED AREA SHOWN IN PROBLEM SYMPTOMS TABLE

OK ► END (NAVIGATION RECEIVER ASSEMBLY WAS DEFECTIVE)

7.	REPLACE RADIO RECEIVER ASSEMBLY
----	---------------------------------

(a) Replace the radio receiver assembly with a known good one and check if the same problem occurs again **INFO** .

OK:

Same problem does not occur.

NG ► PROCEED TO NEXT SUSPECTED AREA SHOWN IN PROBLEM SYMPTOMS TABLE

OK ► END (RADIO RECEIVER ASSEMBLY WAS DEFECTIVE)

8.	CHECK HARNESS AND CONNECTOR (A/C CONTROL ASSEMBLY - SPIRAL WITH SENSOR CABLE SUB-ASSEMBLY)
----	--

*1

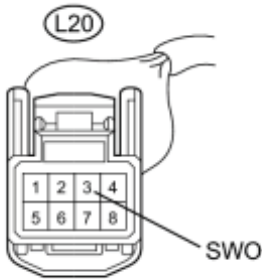

(a) Disconnect the connector from the A/C control assembly.

(b) Measure the resistance according value(s) in the table below.

Standard Resistance:

Tester Connection	Condition	Specified Condition
L20-3 (SWO) - L52-10 (AC1)	Always	Below 1 Ω
L20-3 (SWO) - Body ground	Always	10 kΩ or higher

Text in Illustration



*1	Front view of wire harness connector (to A/C Control Assembly)
*2	Front view of wire harness connector (to Spiral with Sensor Cable Sub-assembly)

H

NG ► REPAIR OR REPLACE HARNESS OR CONNECTOR

OK ► REPLACE A/C CONTROL ASSEMBLY

DESCRIPTION

The integration control and panel sub-assembly (ECO MODE switch) is installed on the instrument panel on the driver side. When the integration control and panel sub-assembly (ECO MODE switch) is turned on, the A/C amplifier receives an integration control and panel sub-assembly (ECO MODE switch) ON signal and controls the air conditioning to enhance fuel efficiency.

When the heater is on, the engine ON request coolant temperature will be set to a lower level. Thus, the length of time that the engine operates to generate the heat necessary to operate the heater will be limited. When the engine coolant temperature drops, the amount of air flow of the blower motor will also decrease. If FOOT/DEF or DEF is selected, or if the temperature is set to MAX HOT, the fuel efficiency control due to the integration control and panel sub-assembly (ECO MODE switch) operation will be canceled.

When the air conditioning is used to cool the vehicle, the power consumption of the compressor will be limited. Initially, the air conditioning will operate normally until the cabin temperature stabilizes. After the cabin temperature stabilizes, the power consumption of the compressor will be limited while stabilizing the cabin temperature. If the temperature is set to MAX COOL, the fuel efficiency control due to the integration control and panel sub-assembly (ECO MODE switch) operation will be canceled.

WIRING DIAGRAM

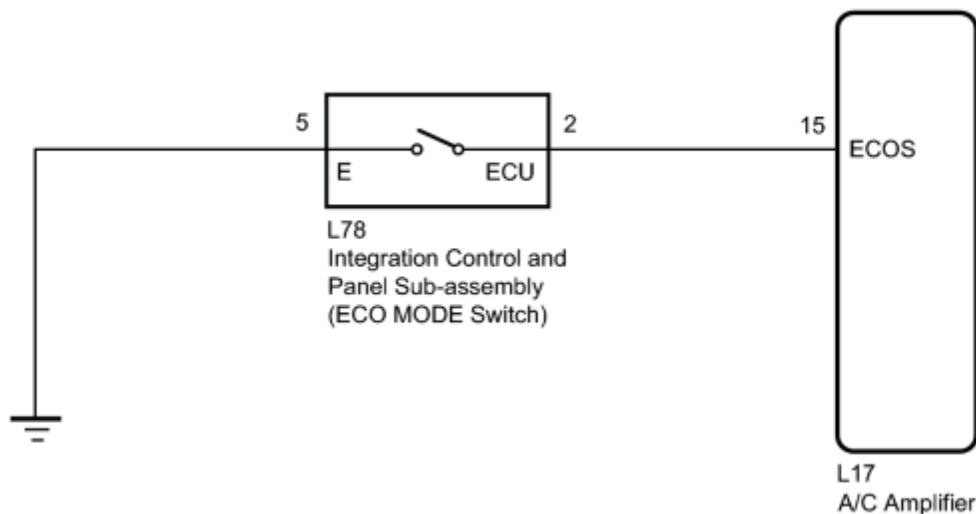

INSPECTION PROCEDURE

PROCEDURE

1. INSPECT AIR CONDITIONING AMPLIFIER

*1

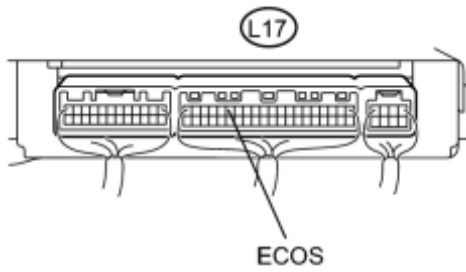

(a) Remove the A/C amplifier with the connectors still connected.

H

(b) Measure the voltage according to the value(s) in the table below.

Standard Voltage:

Tester Connection	Condition	Specified Condition
L17-15 (ECOS) - Body ground	Power switch on (IG) ECO MODE switch off (when switch is not pressed)	11 to 14 V
L17-15 (ECOS) - Body ground	Power switch on (IG) ECO MODE switch on (when switch is pressed)	Below 1 V

Text in Illustration

*1	Component with harness connected (A/C Amplifier)
----	---

NG ► [CHECK HARNESS AND CONNECTOR \(ECO MODE SWITCH - BODY GROUND\)](#)

OK ► **PROCEED TO NEXT SUSPECTED AREA SHOWN IN PROBLEM SYMPTOMS TABLE**

2. CHECK HARNESS AND CONNECTOR (ECO MODE SWITCH - BODY GROUND)

(a) Disconnect the connector from the integration control and panel sub-assembly (ECO MODE switch).

*1

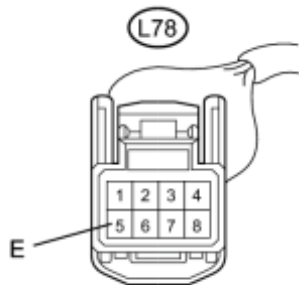

(b) Measure the resistance according to the value(s) in the table below.

Standard Resistance:

Tester Connection	Condition	Specified Condition
L78-5 (E) - Body ground	Always	Below 1 Ω

Text in Illustration

*1	Front view of wire harness connector (to Integration Control and Panel Sub-assembly (ECO MODE Switch))
----	---

NG REPAIR OR REPLACE HARNESS OR CONNECTOR

OK

3. INSPECT INTEGRATION CONTROL AND PANEL SUB-ASSEMBLY (ECO MODE SWITCH)

(a) Measure the resistance according to the value(s) in the table below.

*1

Standard Resistance:

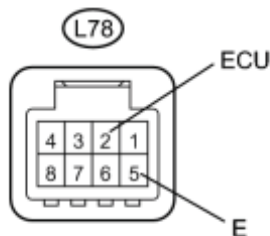

Tester Connection	Condition	Specified Condition
L78-2 (ECU) - L78-5 (E)	ECO MODE switch off (when switch is not pressed)	10 k Ω or higher
L78-2 (ECU) - L78-5 (E)	ECO MODE switch on (when switch is pressed)	Below 1 Ω

Text in Illustration

*1	Component without harness connected (Integration Control and Panel Sub-assembly (ECO MODE Switch))
----	---

NG ▶ REPLACE INTEGRATION CONTROL AND PANEL SUB-ASSEMBLY (ECO MODE SWITCH)

OK



4. CHECK HARNESS AND CONNECTOR (A/C AMPLIFIER - ECO MODE SWITCH)

*1

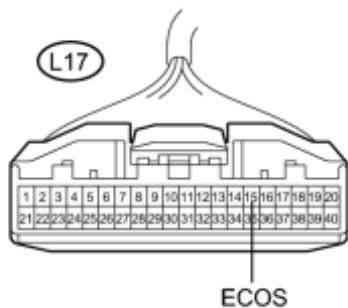

H

(a) Disconnect the connector from the A/C amplifier.

(b) Measure the resistance according to the value(s) in the table below.

Standard Resistance:

*2

Tester Connection	Condition	Specified Condition
L17-15 (ECOS) - L78-2 (ECU)	Always	Below 1 Ω
L17-15 (ECOS) - Body ground	Always	10 k Ω or higher

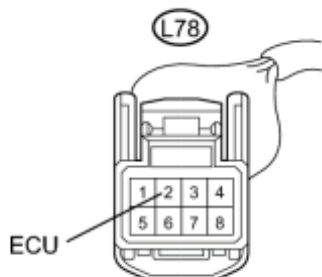

Text in Illustration

*1	Front view of wire harness connector (to A/C Amplifier)
*2	Front view of wire harness connector (to Integration Control and Panel Sub-assembly (ECO MODE Switch))

NG ▶ REPAIR OR REPLACE HARNESS OR CONNECTOR

OK  **REPLACE A/C AMPLIFIER**

DESCRIPTION

The main power source is supplied to the A/C amplifier when the power switch is on (IG).

The power source is used for operating the A/C amplifier and servo motor, etc.

WIRING DIAGRAM

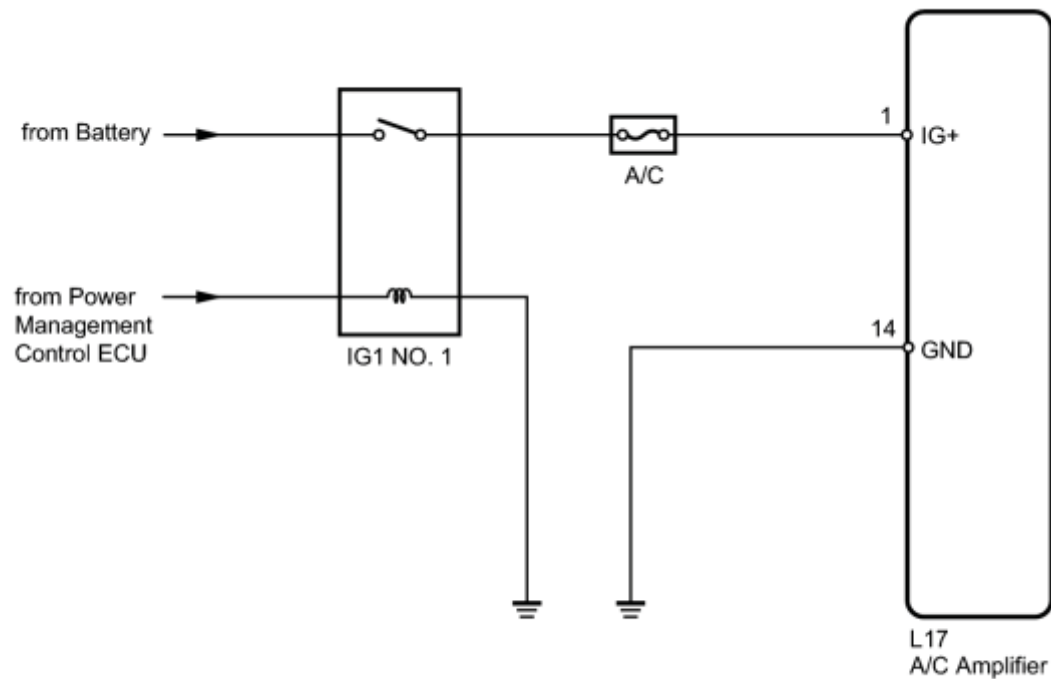

INSPECTION PROCEDURE

NOTICE:

Inspect the fuses for circuits related to this system before performing the following inspection procedure.

HINT:

Turn the power switch on (IG) before inspection. Check the IG1 NO. 1 relay or auxiliary battery if the power source does not change to on (IG).

PROCEDURE

1. INSPECT A/C AMPLIFIER

*1

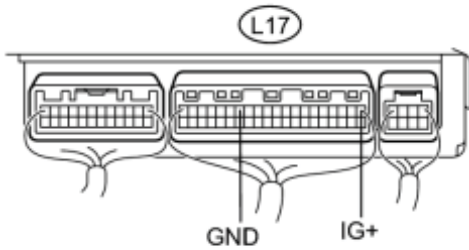

(a) Remove the A/C amplifier with its connectors still connected.

(b) Measure the voltage according to the value(s) in the table below.

Standard Voltage:

Tester Connection	Condition	Specified Condition
L17-1 (IG+) - L17-14 (GND)	Power switch off	Below 1 V
L17-1 (IG+) - L17-14 (GND)	Power switch on (IG)	11 to 14 V

Text in Illustration

*1	Component with harness connected (A/C Amplifier)
----	---

NG **CHECK HARNESS AND CONNECTOR (A/C AMPLIFIER - BATTERY)**

OK **PROCEED TO NEXT SUSPECTED AREA SHOWN IN PROBLEM SYMPTOMS TABLE**

2. CHECK HARNESS AND CONNECTOR (A/C AMPLIFIER - BATTERY)

(a) Disconnect the A/C amplifier connector.

*1

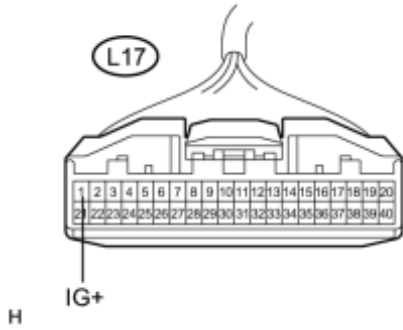

(b) Measure the voltage according to the value(s) in the table below.

Standard Voltage:

Tester Connection	Condition	Specified Condition
L17-1 (IG+) - Body ground	Power switch off	Below 1 V
L17-1 (IG+) - Body ground	Power switch on (IG)	11 to 14 V

Text in Illustration

*1	Front view of wire harness connector (to A/C Amplifier)
----	--

NG ► REPAIR OR REPLACE HARNESS OR CONNECTOR

OK



3.	CHECK HARNESS AND CONNECTOR (A/C AMPLIFIER - BODY GROUND)
----	---

*1

(a) Measure the resistance according to the value(s) in the table below.

Standard Resistance:

Tester Connection	Condition	Specified Condition
L17-14 (GND) - Body ground	Always	Below 1 Ω

Text in Illustration

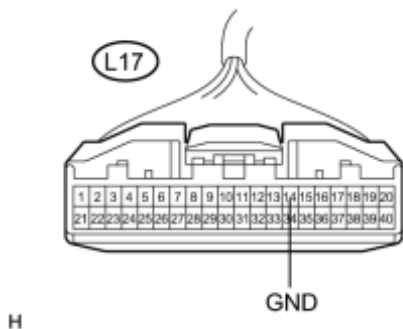

*1	Front view of wire harness connector (to A/C Amplifier)
----	--

NG  REPAIR OR REPLACE HARNESS OR CONNECTOR

OK  **REPLACE A/C AMPLIFIER**

DESCRIPTION

The back-up power source circuit for the A/C amplifier is shown below. Power is supplied even when the power switch is turned off. The power is used for diagnostic trouble code memory etc.

WIRING DIAGRAM

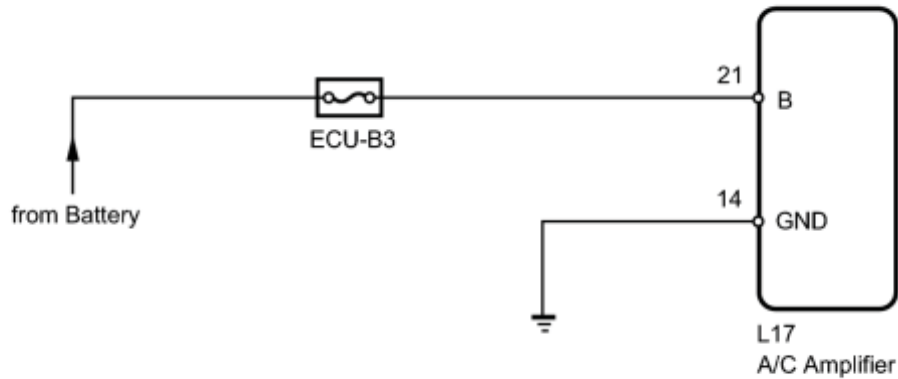

INSPECTION PROCEDURE

NOTICE:

Inspect the fuses for circuits related to this system before performing the following inspection procedure.

PROCEDURE

1. CHECK HARNESS AND CONNECTOR (A/C AMPLIFIER - BATTERY)

(a) Disconnect the A/C amplifier connector.

*1

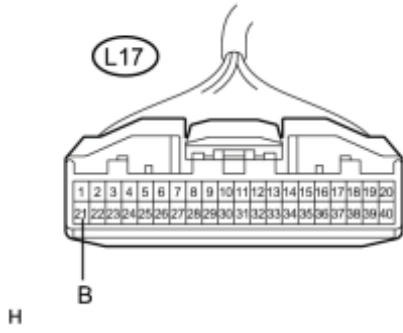

(b) Measure the voltage according to the value(s) in the table below.

Standard Voltage:

Tester Connection	Condition	Specified Condition
L17-21 (B) - Body ground	Power switch off	11 to 14 V

Text in Illustration

*1	Front view of wire harness connector (to A/C Amplifier)
----	--

NG ► REPAIR OR REPLACE HARNESS OR CONNECTOR

OK



2.	CHECK HARNESS AND CONNECTOR (A/C AMPLIFIER - BODY GROUND)
----	---

*1

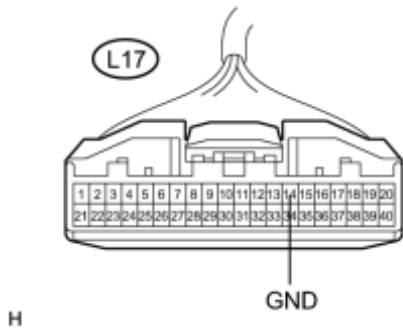

(a) Disconnect the A/C amplifier connector.

(b) Measure the resistance according to the value(s) in the table below.

Standard Resistance:

Tester Connection	Condition	Specified Condition
L17-14 (GND) - Body ground	Always	Below 1 Ω

Text in Illustration

*1	Front view of wire harness connector (to A/C Amplifier)
----	--

NG  REPAIR OR REPLACE HARNESS OR CONNECTOR

OK  PROCEED TO NEXT SUSPECTED AREA SHOWN IN PROBLEM SYMPTOMS TABLE

COMPONENTS

ILLUSTRATION

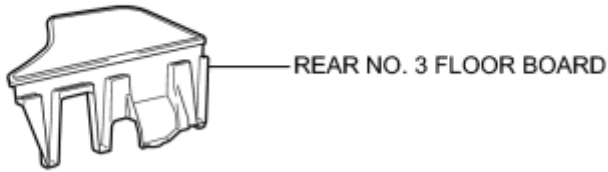

for Integrated Type:

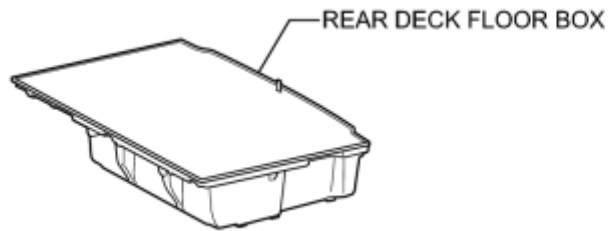

for Separate Type:

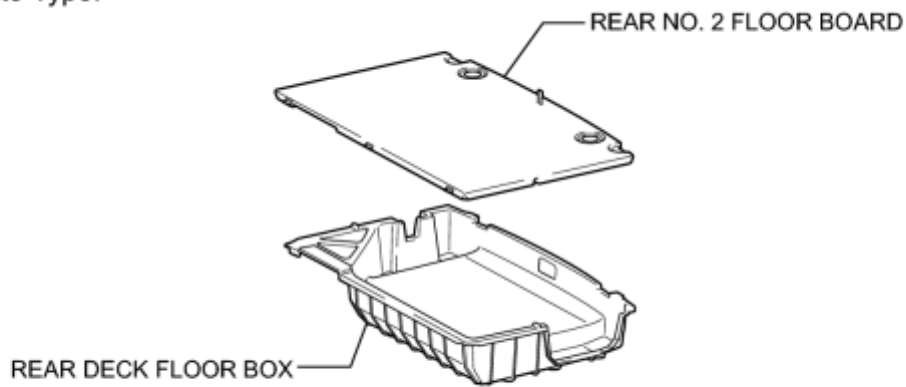

P

ILLUSTRATION

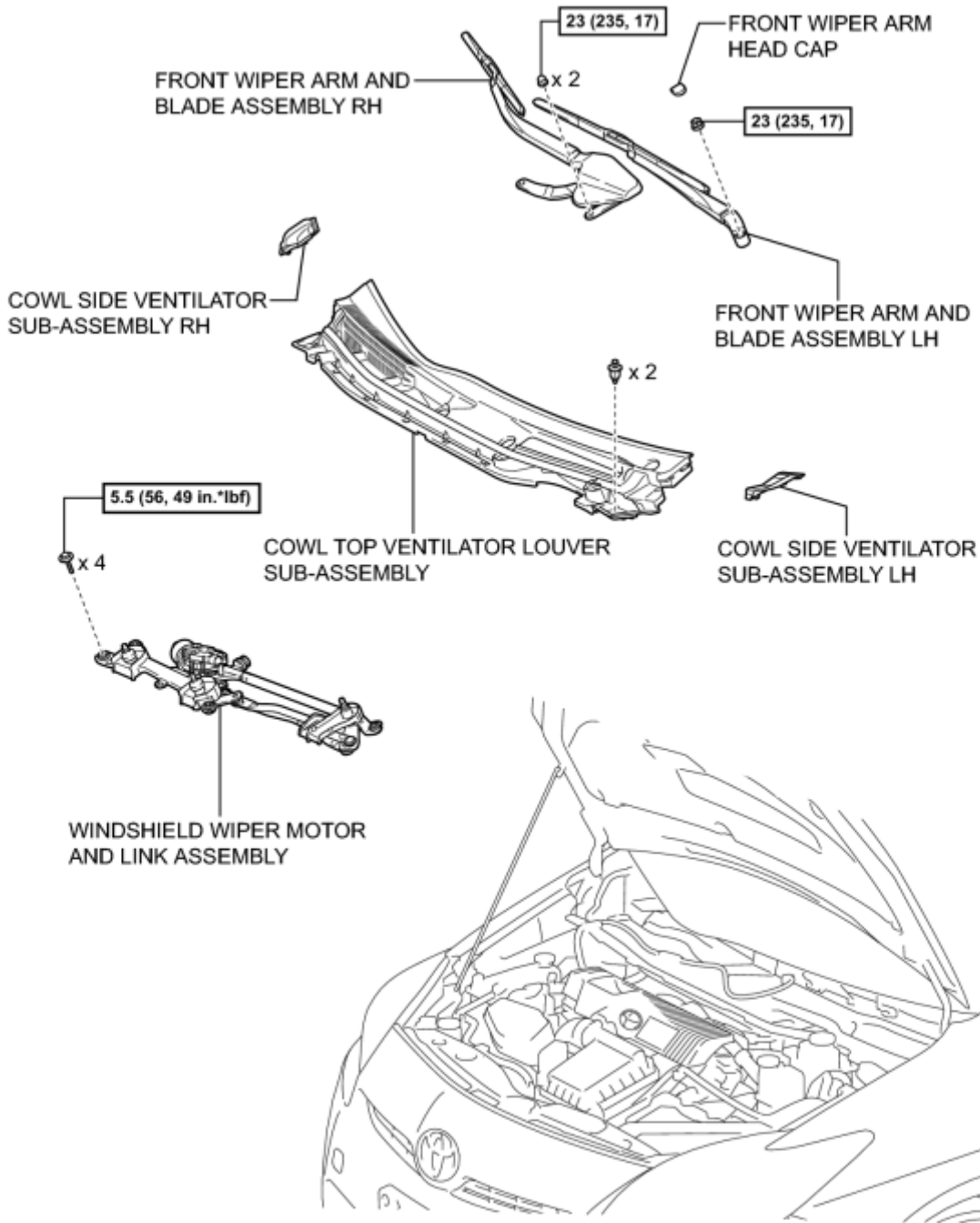

N*m (kgf*cm, ft.*lbf): Specified torque

P

ILLUSTRATION

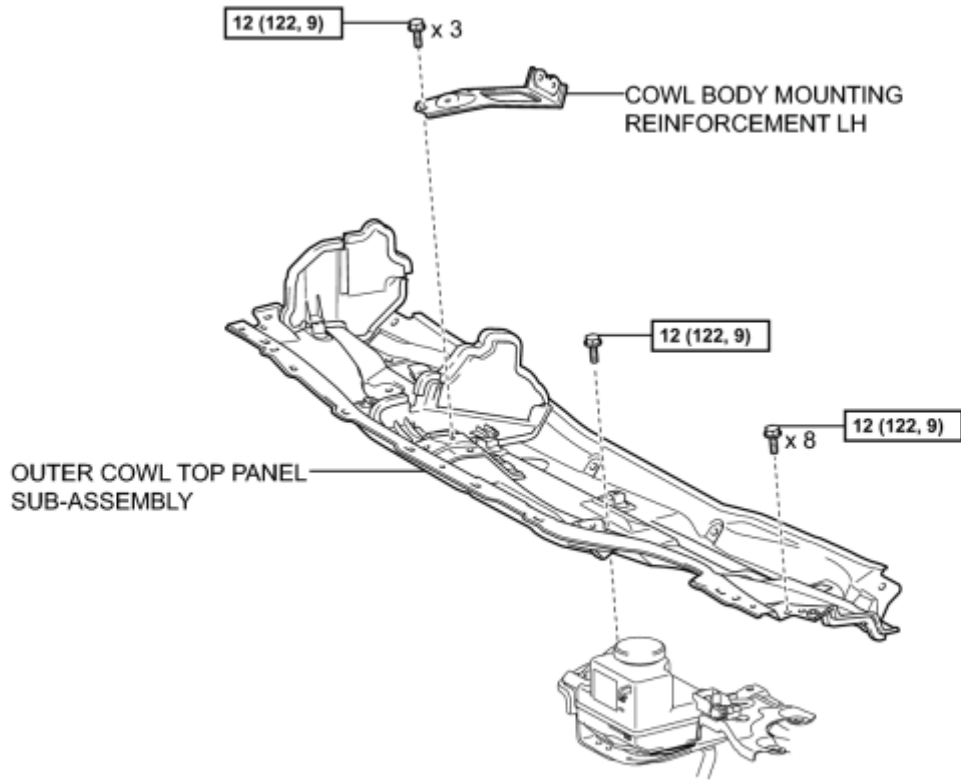

N*m (kgf*cm, ft.*lbf) : Specified torque

P

ILLUSTRATION

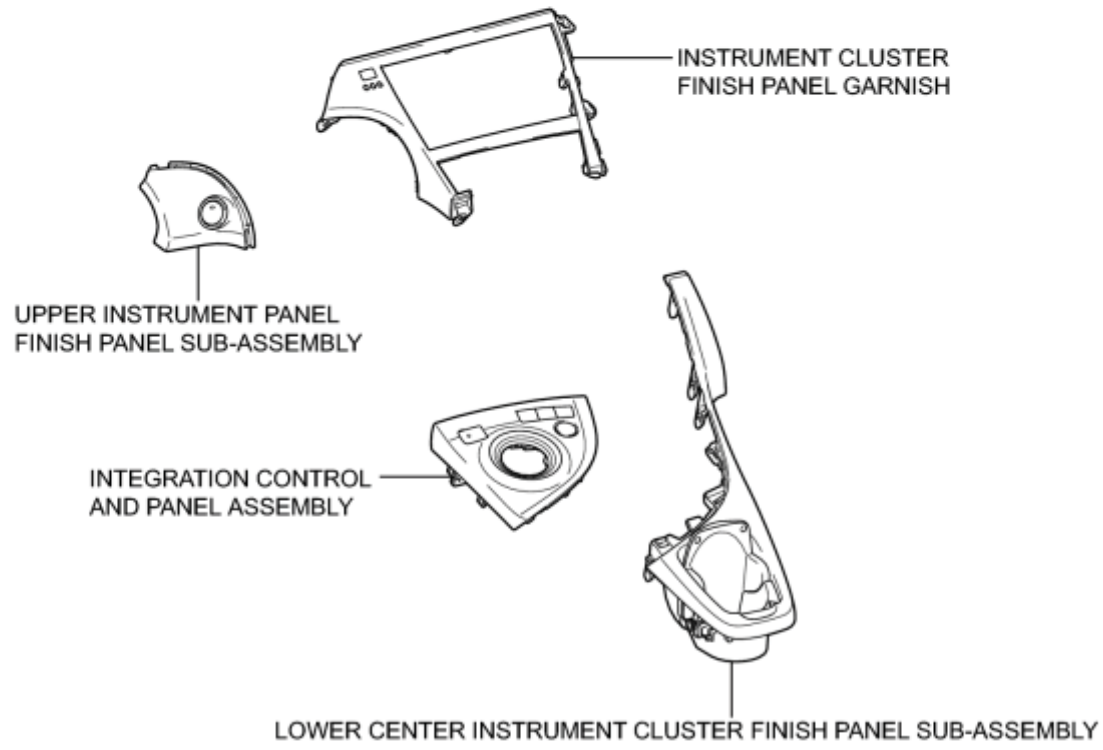
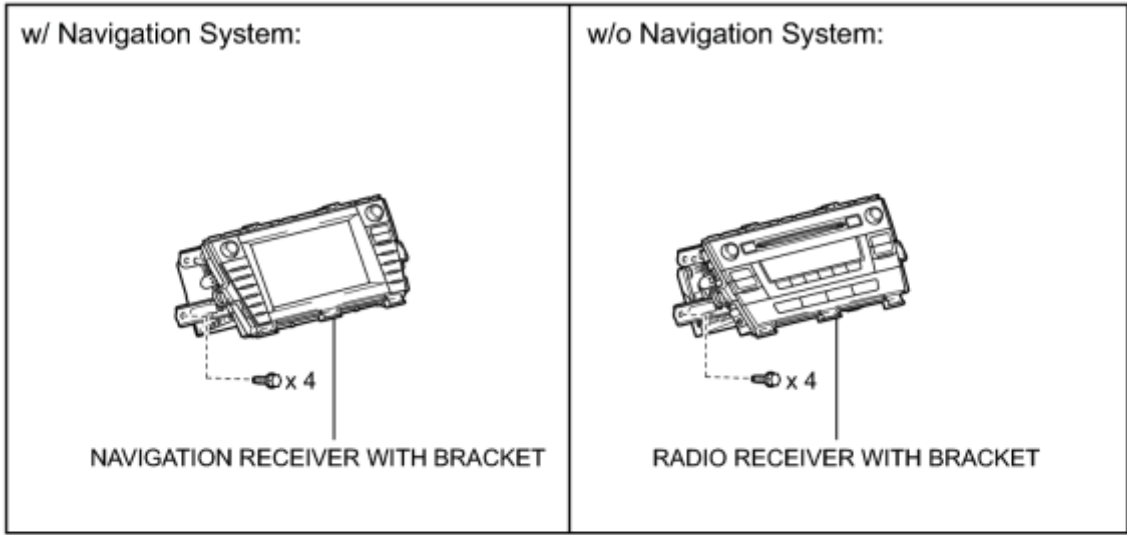

P

ILLUSTRATION

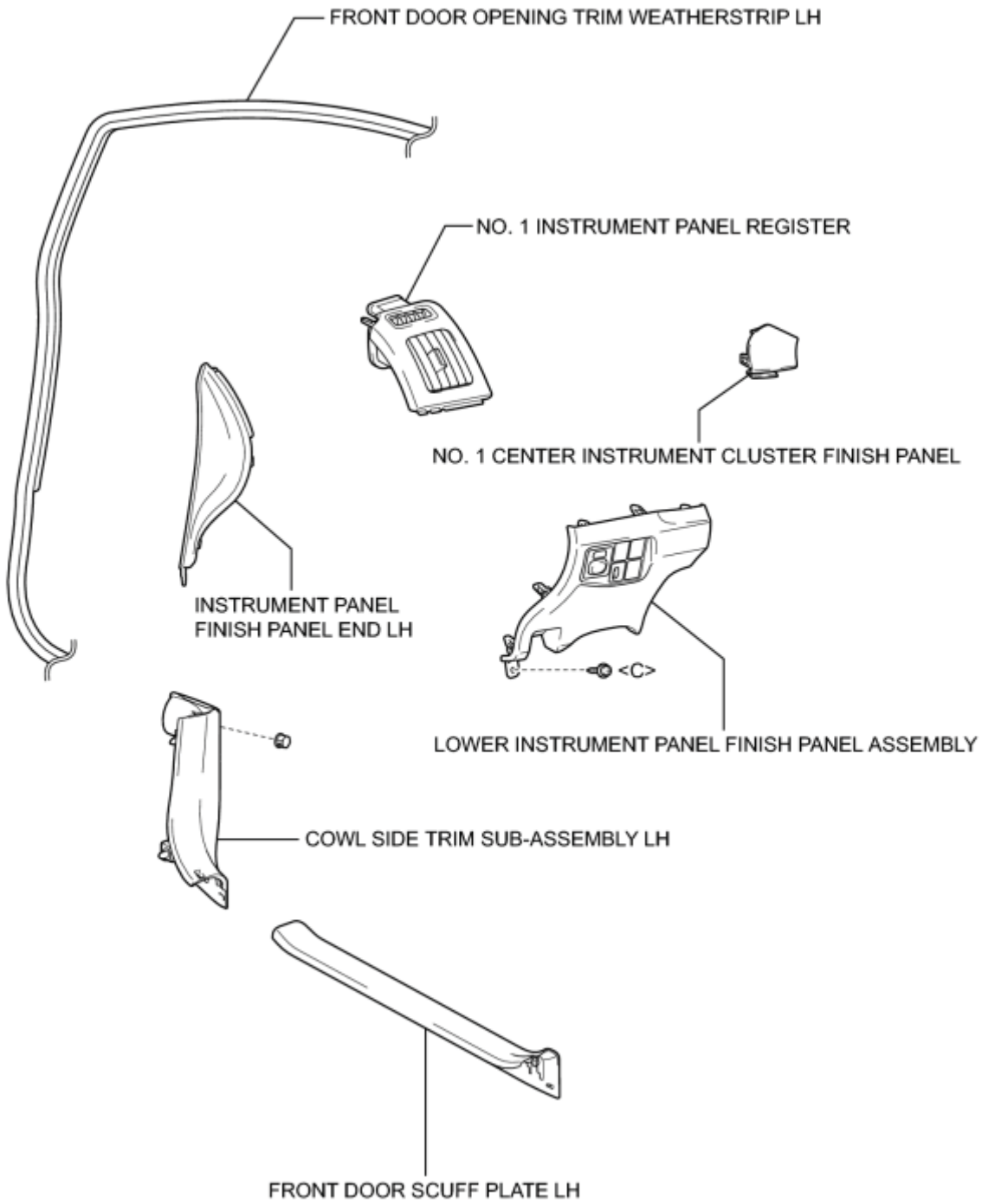

P

ILLUSTRATION

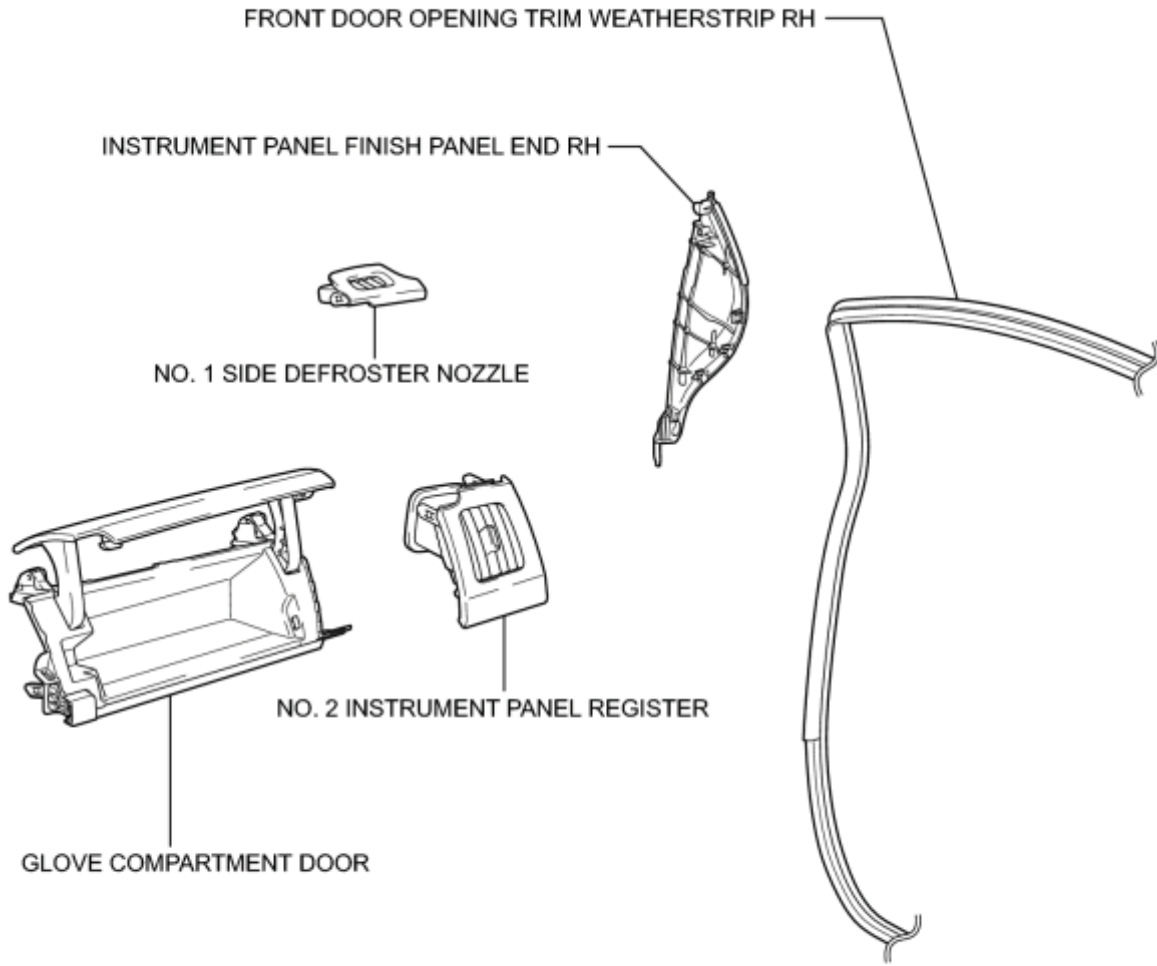

P

ILLUSTRATION

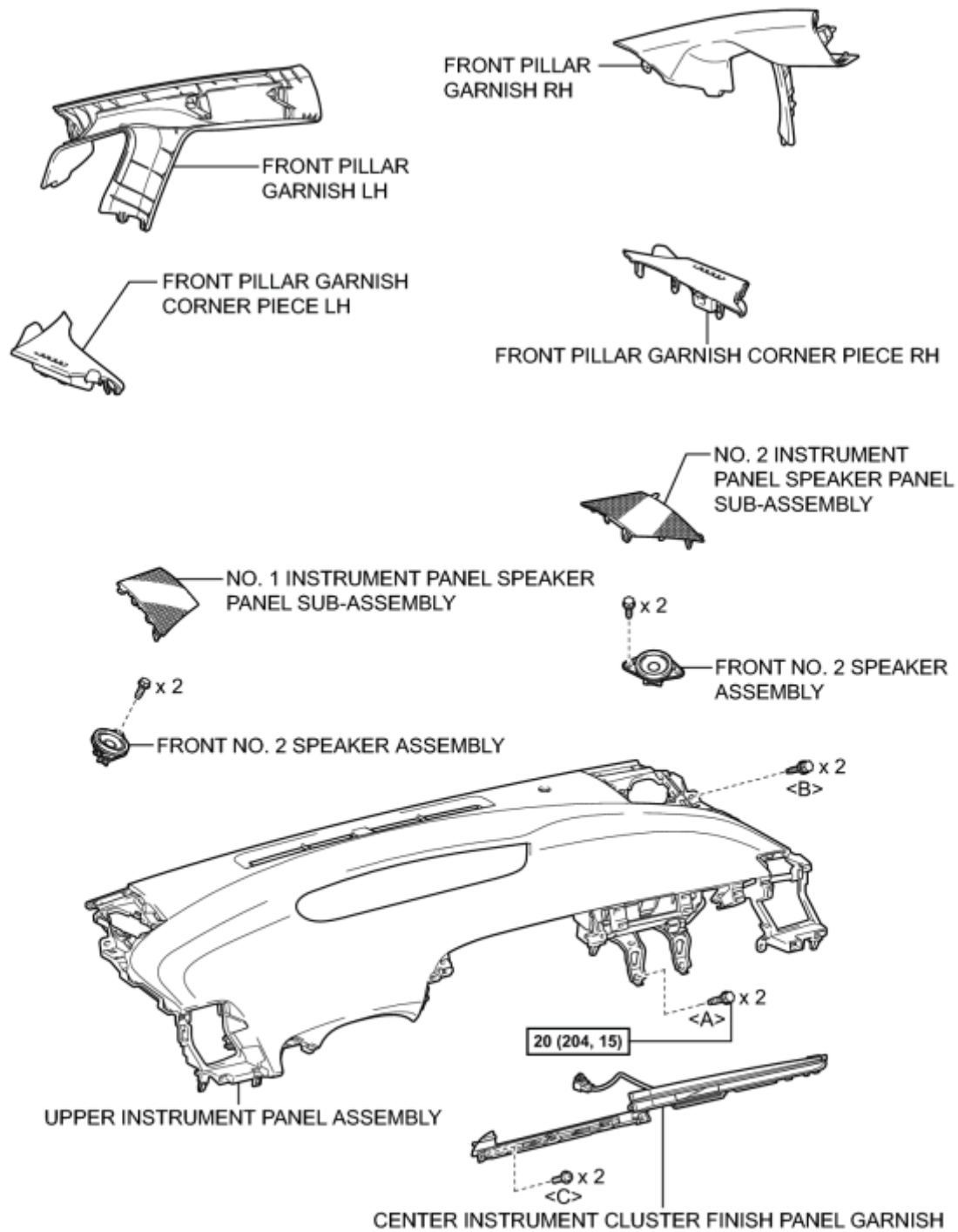

N*m (kgf*cm, ft.*lbf) : Specified torque

P

ILLUSTRATION

w/ Power Outlet Socket:

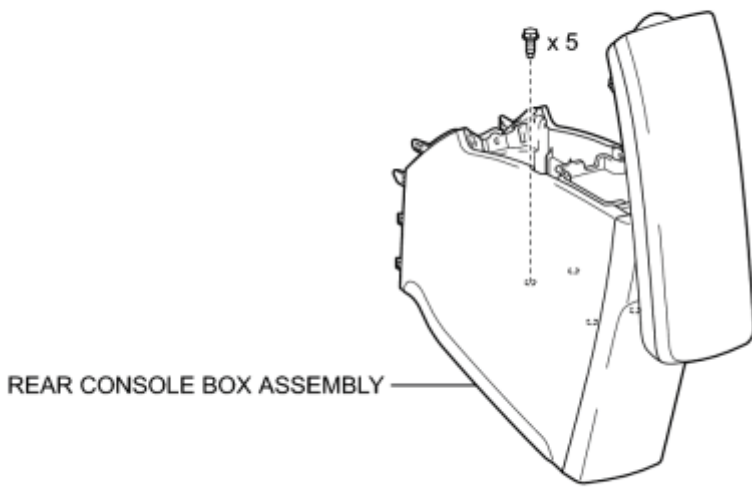
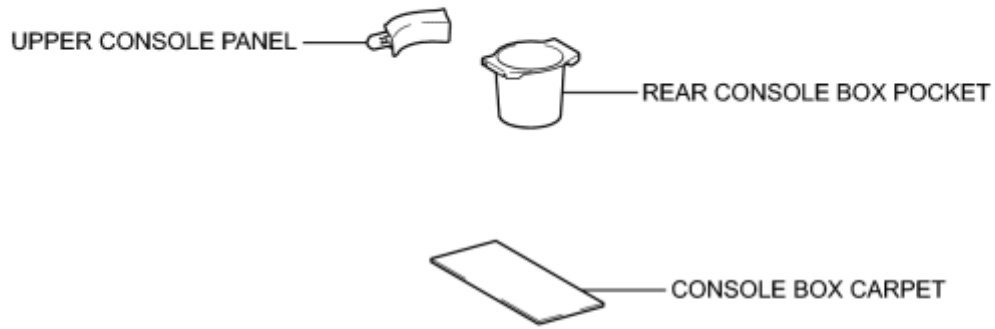

P

ILLUSTRATION

w/o Power Outlet Socket:

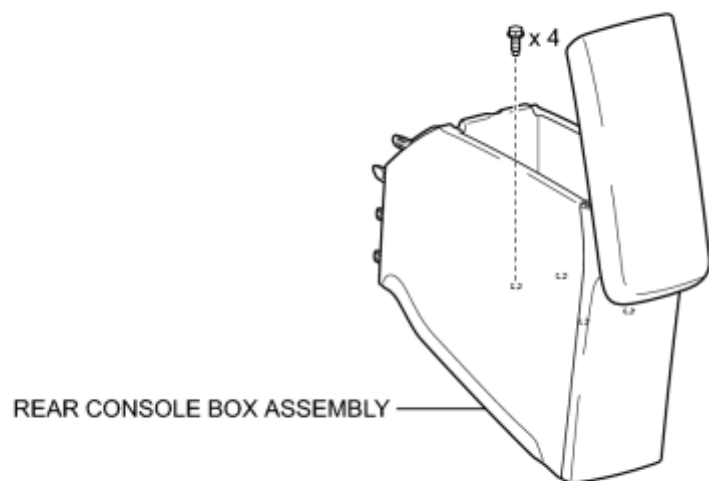

P

ILLUSTRATION

AIR CONDITIONING CONTROL ASSEMBLY



SHIFT LOCK CONTROL UNIT ASSEMBLY

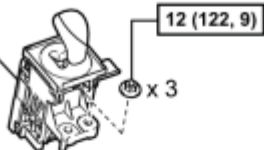

12 (122, 9)

x 3

UPPER INSTRUMENT PANEL FINISH PANEL ASSEMBLY

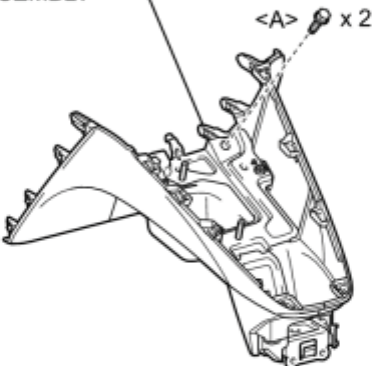

<A> x 2

FRONT NO. 1 CONSOLE BOX INSERT



FRONT NO. 2 CONSOLE BOX INSERT



BOX BOTTOM MAT

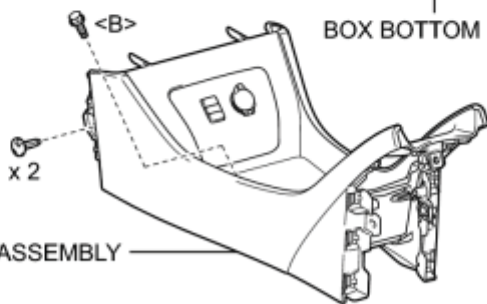

x 2

CONSOLE BOX ASSEMBLY

NO. 2 CONSOLE BOX MOUNTING BRACKET

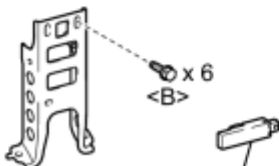

x 6

ELECTRICAL KEY OSCILLATOR



N·m (kgf·cm, ft.*lbf): Specified torque

P

ILLUSTRATION

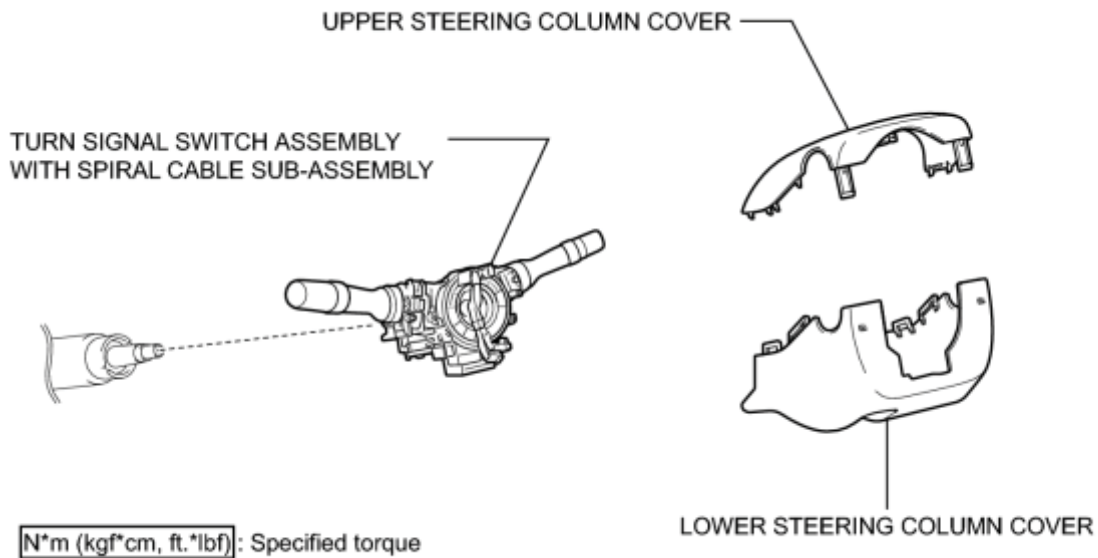
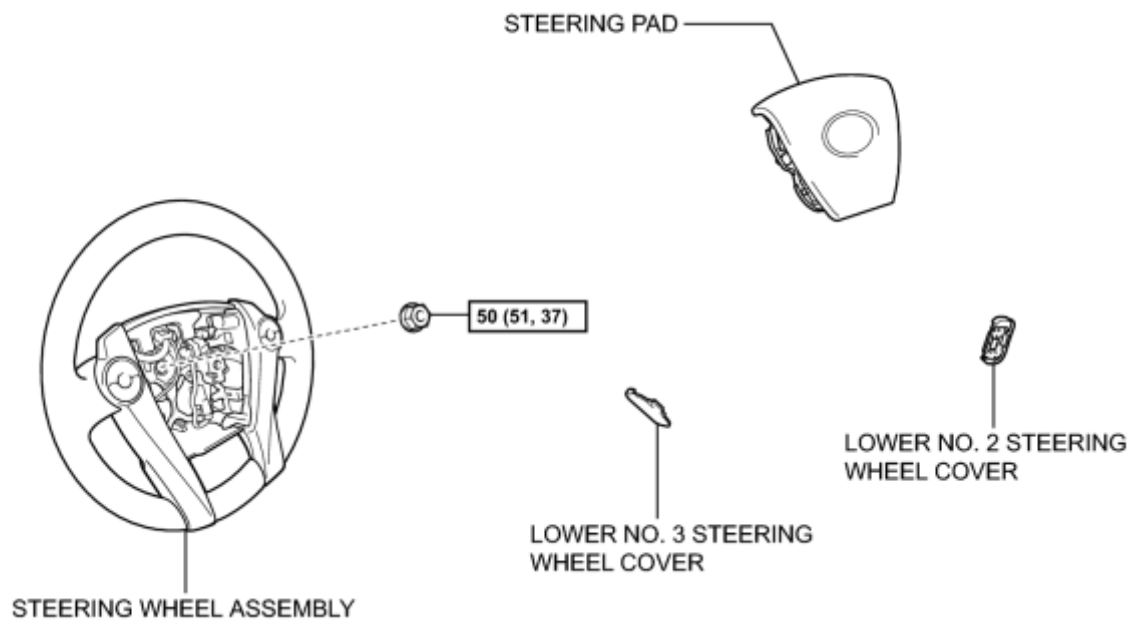

ILLUSTRATION

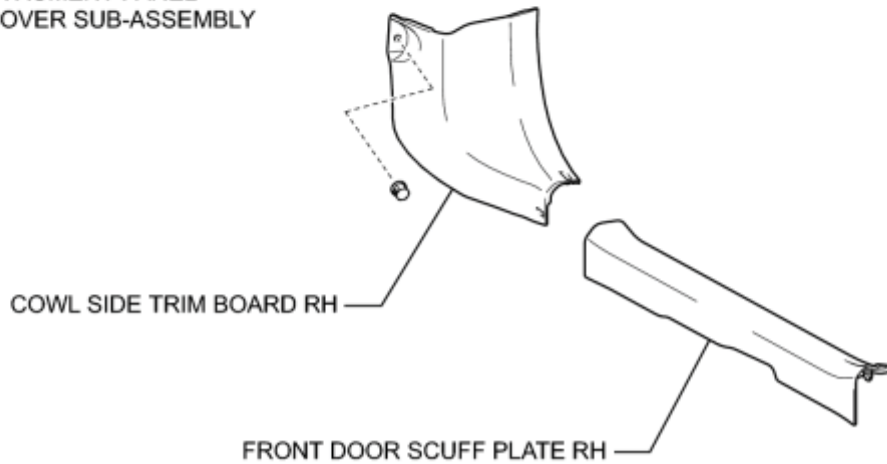
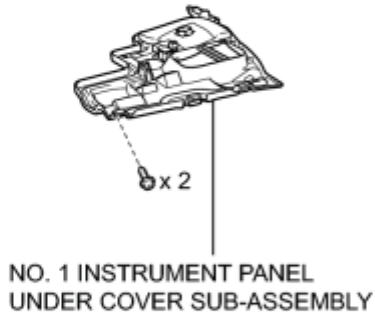
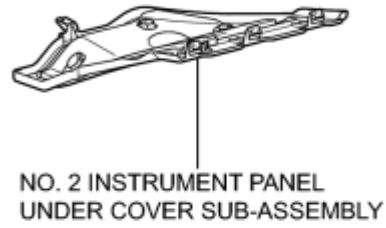
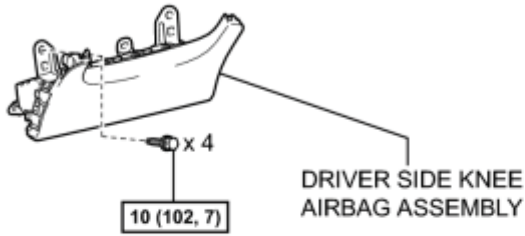
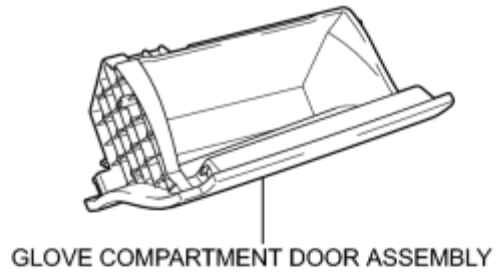
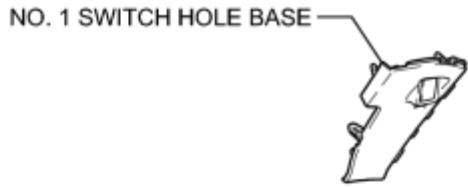

N*m (kgf*cm, ft.*lbf): Specified torque

P

ILLUSTRATION

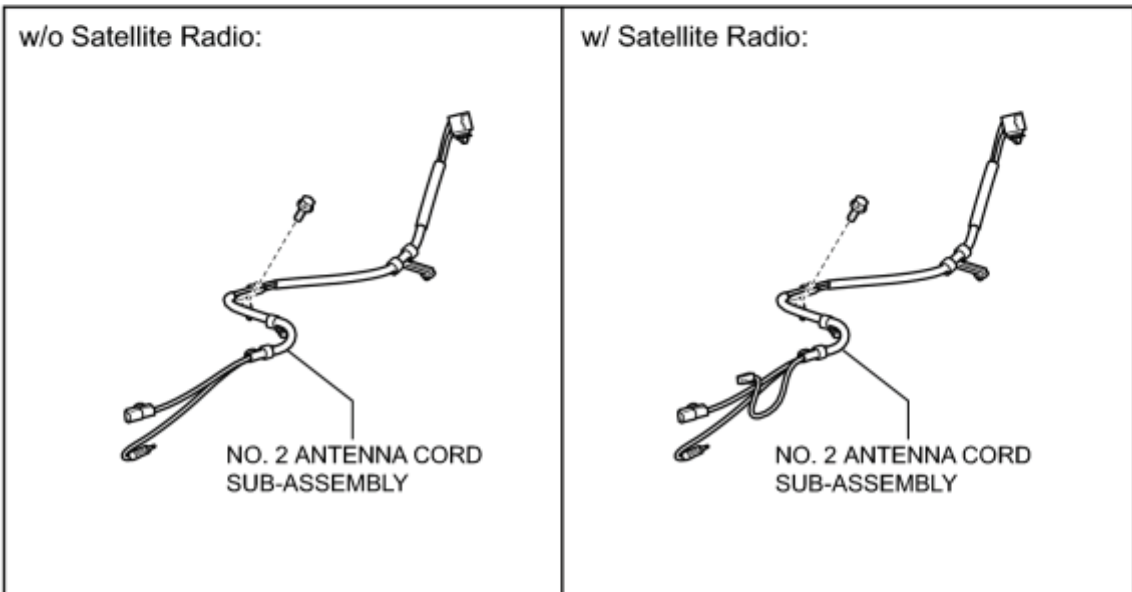
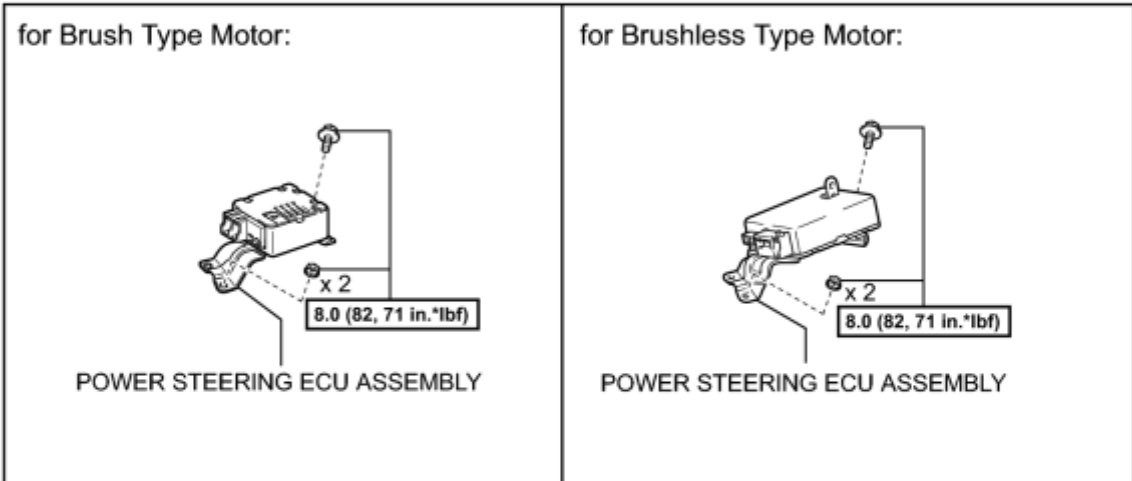
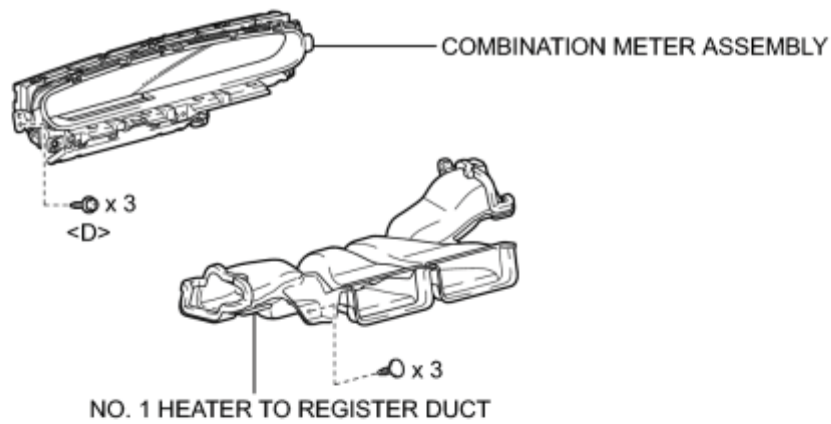

N*m (kgf*cm, ft.*lbf): Specified torque

P

ILLUSTRATION

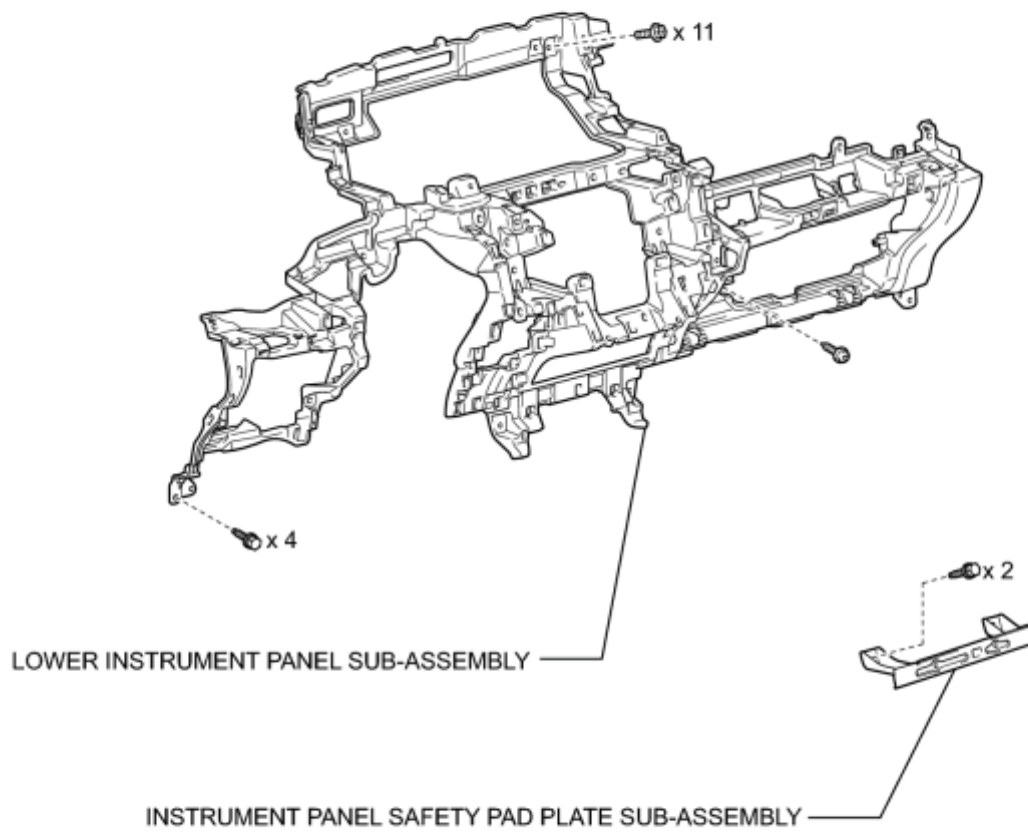

P

ILLUSTRATION

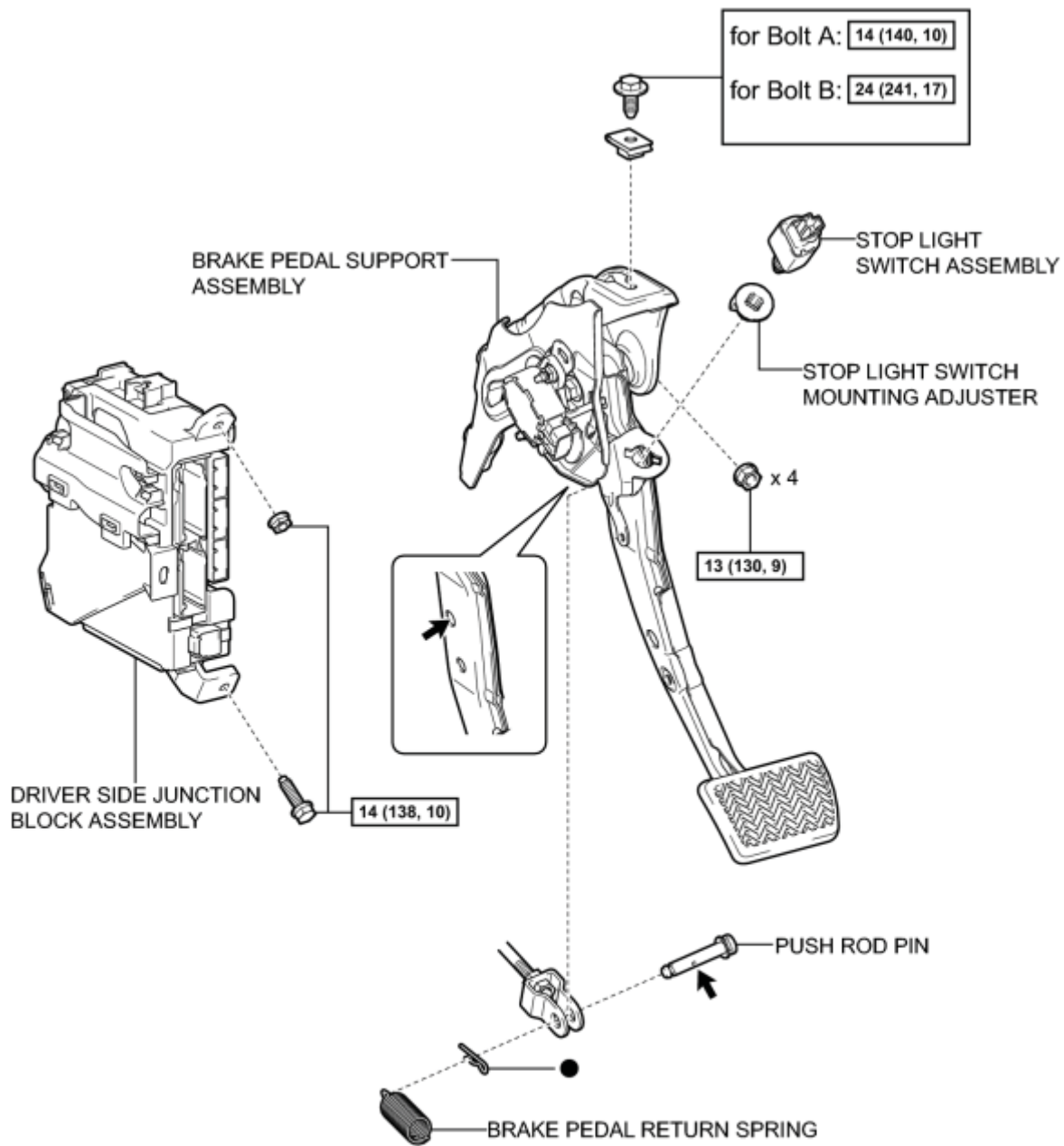

N*m (kgf*cm, ft.*lbf) : Specified torque

● Non-reusable part

← Lithium soap base glycol grease

P

ILLUSTRATION

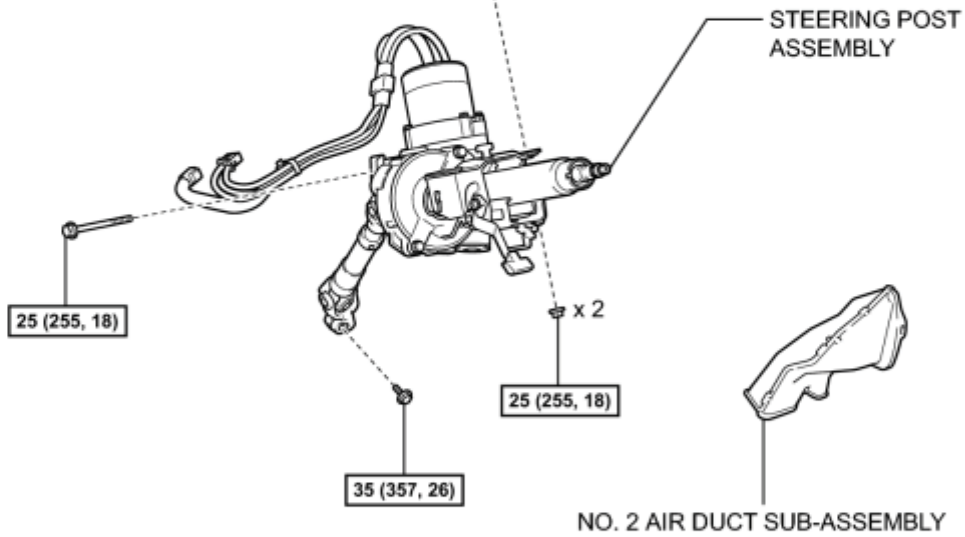
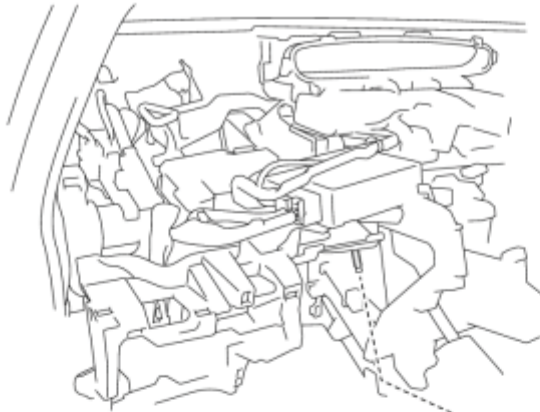

N*m (kgf*cm, ft.*lbf): Specified torque

c

ILLUSTRATION

w/ Rear Air Duct:

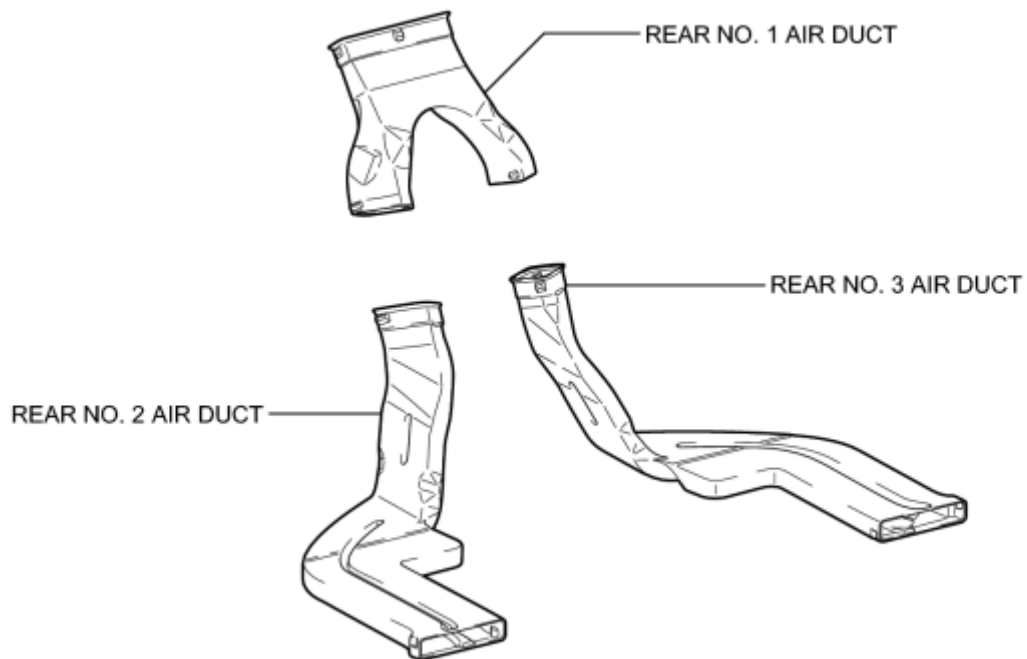

P

ILLUSTRATION

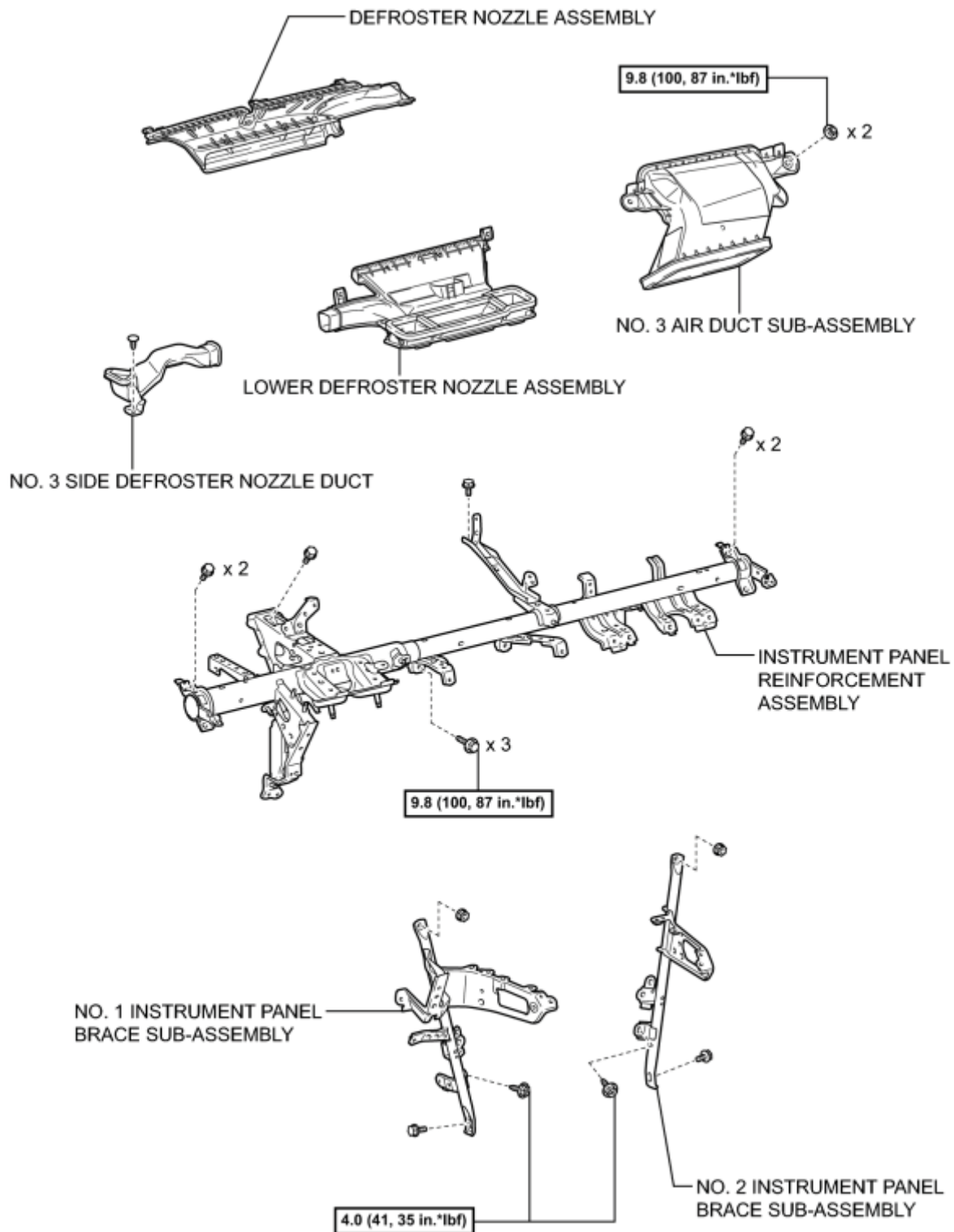

[N*m (kgf*cm, ft.*lbf)]: Specified torque

P

ILLUSTRATION

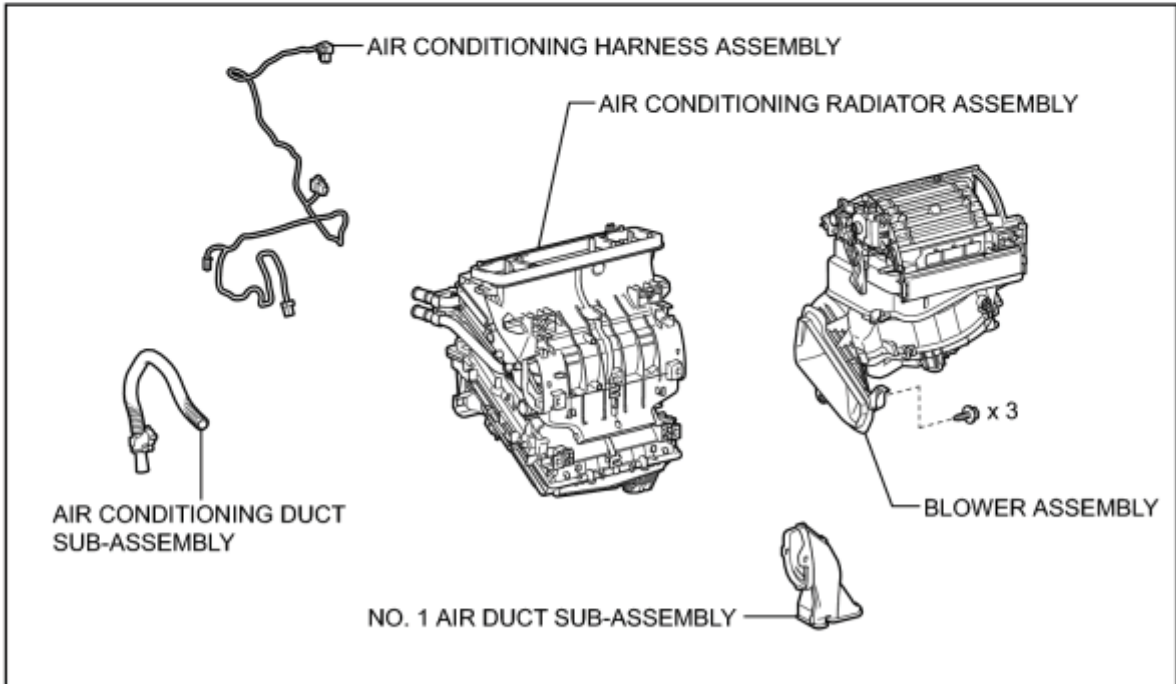
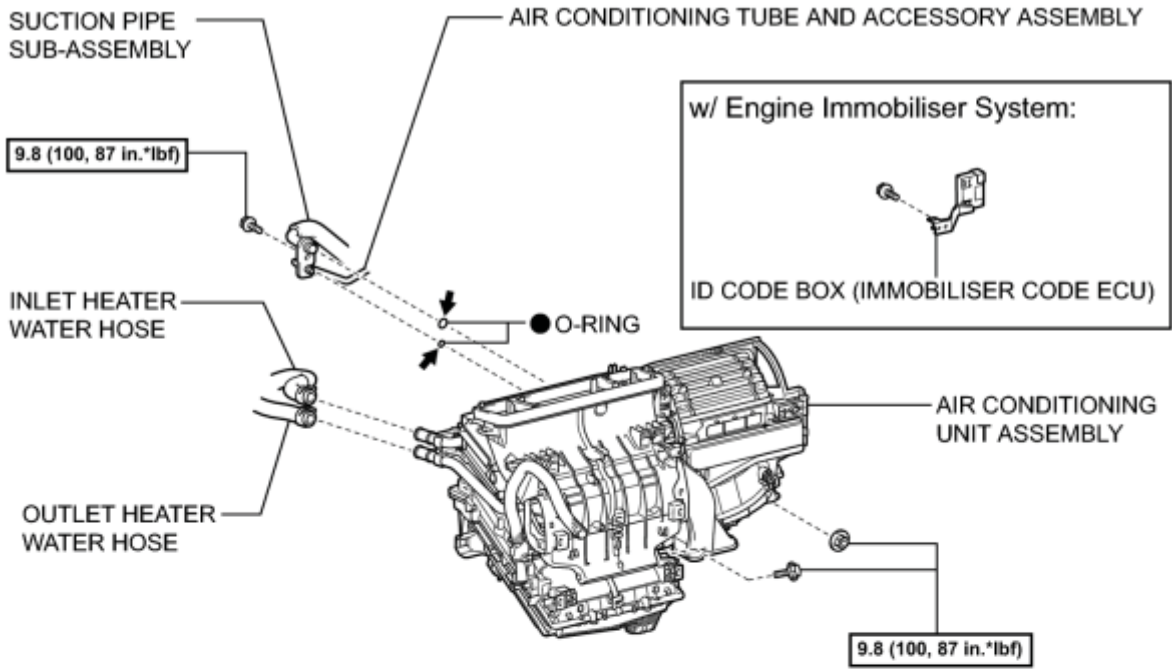

9.8 (100, 87 in.*lbf): Specified torque

● Non-reusable part

← Compressor oil ND-OIL 11 or equivalent

P

ILLUSTRATION

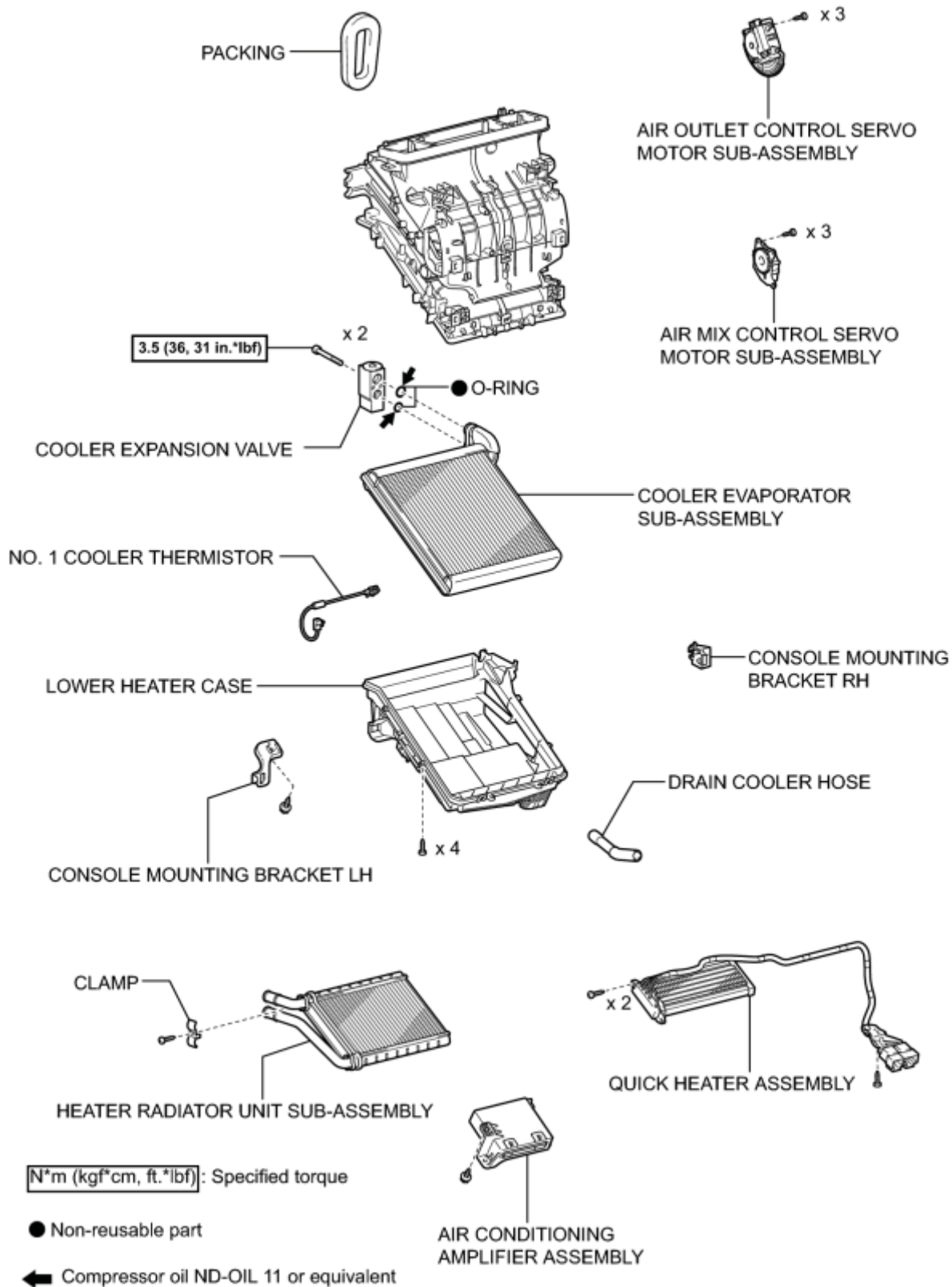

P

REMOVAL

1. PRECAUTION

INFO

HINT:

Before disconnecting the cable, set the air conditioning control switch to DEF-MODE. (for Automatic Air Conditioning System)

2. RECOVER REFRIGERANT FROM REFRIGERATION SYSTEM_

INFO

3. ALIGN FRONT WHEELS STRAIGHT AHEAD

4. REMOVE REAR NO. 2 FLOOR BOARD (for Separate Type)_

INFO

5. REMOVE REAR DECK FLOOR BOX_

INFO

6. REMOVE REAR NO. 3 FLOOR BOARD_

INFO

7. DISCONNECT CABLE FROM NEGATIVE BATTERY TERMINAL

CAUTION:

Wait at least 90 seconds after disconnecting the cable from the negative (-) battery terminal to disable the SRS system.

NOTICE:

When disconnecting the cable, some systems need to be initialized after the cable is reconnected.

INFO

8. REMOVE FRONT WIPER ARM HEAD CAP_

INFO

9. REMOVE FRONT WIPER ARM AND BLADE ASSEMBLY LH_

INFO

10. REMOVE FRONT WIPER ARM AND BLADE ASSEMBLY RH_

INFO

11. REMOVE COWL SIDE VENTILATOR SUB-ASSEMBLY LH_

INFO

12. REMOVE COWL SIDE VENTILATOR SUB-ASSEMBLY RH_

INFO

13. REMOVE COWL TOP VENTILATOR LOUVER SUB-ASSEMBLY_

INFO

14. REMOVE WINDSHIELD WIPER MOTOR AND LINK ASSEMBLY_

INFO

15. REMOVE COWL BODY MOUNTING REINFORCEMENT LH_

INFO

16. REMOVE OUTER COWL TOP PANEL SUB-ASSEMBLY_

INFO

17. DISCONNECT SUCTION PIPE SUB-ASSEMBLY

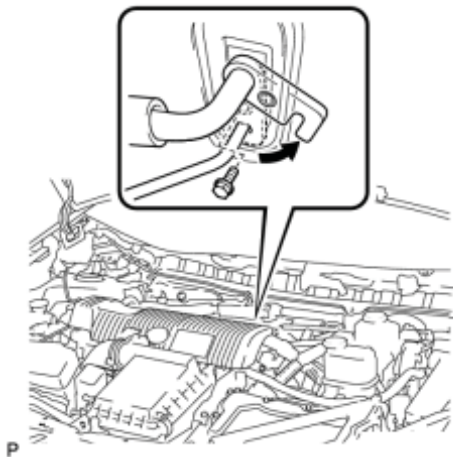

(a) Remove the bolt and slide the hook connector.

(b) Disconnect the suction pipe assembly.

(c) Remove the O-ring from the suction pipe sub-assembly.

NOTICE:

Seal the openings of the disconnected parts using vinyl tape to prevent entry of moisture and foreign matter.

18. DISCONNECT AIR CONDITIONING TUBE AND ACCESSORY ASSEMBLY

(a) Disconnect the air conditioning tube and accessory assembly.

(b) Remove the O-ring from the air conditioning tube and accessory assembly.

NOTICE:

Seal the openings of the disconnected parts using vinyl tape to prevent entry of moisture and foreign matter.

19. DISCONNECT INLET HEATER WATER HOSE

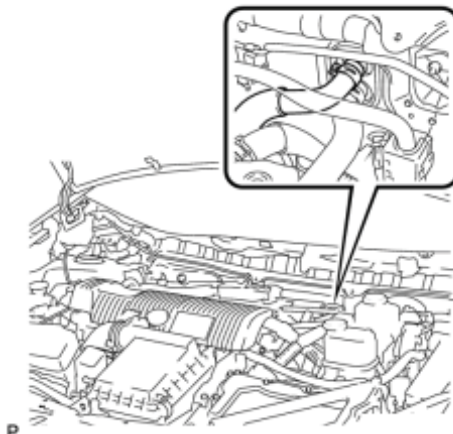

(a) Using pliers, grip the claws of the clip and slide the clip to disconnect the inlet heater water hose.

- Do not apply excessive force to the inlet heater water hose.
- Prepare a drain pan or cloth in case the coolant leaks.

20. DISCONNECT OUTLET HEATER WATER HOSE

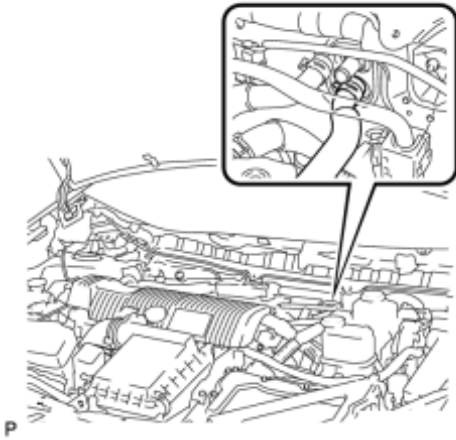

(a) Using pliers, grip the claws of the clip and slide the clip to disconnect the outlet heater water hose.

- Do not apply excessive force to the outlet heater water hose.
- Prepare a drain pan or cloth in case the coolant leaks.

21. REMOVE INTEGRATION CONTROL AND PANEL ASSEMBLY_ [INFO](#)

22. REMOVE LOWER CENTER INSTRUMENT CLUSTER FINISH PANEL SUB-ASSEMBLY_ [INFO](#)

23. REMOVE INSTRUMENT CLUSTER FINISH PANEL GARNISH_ [INFO](#)

24. REMOVE UPPER INSTRUMENT PANEL FINISH PANEL SUB-ASSEMBLY_ [INFO](#)

25. REMOVE RADIO RECEIVER WITH BRACKET (w/o Navigation System)_ [INFO](#)

26. REMOVE NAVIGATION RECEIVER WITH BRACKET (w/ Navigation System)_ [INFO](#)

27. REMOVE FRONT DOOR SCUFF PLATE LH_ [INFO](#)

28. REMOVE COWL SIDE TRIM SUB-ASSEMBLY LH_ [INFO](#)

29. REMOVE LOWER INSTRUMENT PANEL FINISH PANEL ASSEMBLY_ [INFO](#)

30. REMOVE NO. 1 INSTRUMENT PANEL REGISTER_ [INFO](#)

31. REMOVE NO. 1 CENTER INSTRUMENT CLUSTER FINISH PANEL_ [INFO](#)

32. DISCONNECT FRONT DOOR OPENING TRIM WEATHERSTRIP LH_ [INFO](#)

33. REMOVE INSTRUMENT PANEL FINISH PANEL END LH_ [INFO](#)

34. REMOVE NO. 1 SIDE DEFROSTER NOZZLE_ [INFO](#)

35. REMOVE NO. 2 INSTRUMENT PANEL REGISTER_ [INFO](#)

36. REMOVE GLOVE COMPARTMENT DOOR_ [INFO](#)

37. REMOVE FRONT DOOR OPENING TRIM WEATHERSTRIP RH

HINT:

Use the same procedure for the RH side and LH side.

38. REMOVE INSTRUMENT PANEL FINISH PANEL END RH_ [INFO](#)

39. REMOVE FRONT PILLAR GARNISH LH_ [INFO](#)

40. REMOVE FRONT PILLAR GARNISH CORNER PIECE LH_ [INFO](#)

41. REMOVE NO. 1 INSTRUMENT PANEL SPEAKER PANEL SUB-ASSEMBLY_ [INFO](#)

42. REMOVE FRONT NO. 2 SPEAKER ASSEMBLY_ [INFO](#)

43. REMOVE FRONT PILLAR GARNISH RH

HINT:

Use the same procedure for the RH side and LH side.

44. REMOVE FRONT PILLAR GARNISH CORNER PIECE RH_ [INFO](#)

45. REMOVE NO. 2 INSTRUMENT PANEL SPEAKER PANEL SUB-ASSEMBLY_ [INFO](#)

46. REMOVE FRONT NO. 2 SPEAKER ASSEMBLY

HINT:

Use the same procedure for the RH side and LH side.

47. REMOVE CENTER INSTRUMENT CLUSTER FINISH PANEL GARNISH_ [INFO](#)

48. DISCONNECT INSTRUMENT PANEL WIRE_ [INFO](#)

49. REMOVE UPPER INSTRUMENT PANEL ASSEMBLY_ [INFO](#)

50. REMOVE REAR CONSOLE BOX POCKET (w/ Power Outlet Socket)_ [INFO](#)

51. REMOVE UPPER CONSOLE PANEL (w/ Power Outlet Socket)_ [INFO](#)

52. REMOVE CONSOLE BOX CARPET_ [INFO](#)

53. REMOVE REAR CONSOLE BOX ASSEMBLY (w/ Power Outlet Socket)_ [INFO](#)

54. REMOVE REAR CONSOLE BOX ASSEMBLY (w/o Power Outlet Socket)_ [INFO](#)

55. REMOVE ELECTRICAL KEY OSCILLATOR_ [INFO](#)

56. REMOVE NO. 2 CONSOLE BOX MOUNTING BRACKET_ [INFO](#)
57. REMOVE FRONT NO. 1 CONSOLE BOX INSERT_ [INFO](#)
58. REMOVE FRONT NO. 2 CONSOLE BOX INSERT_ [INFO](#)
59. REMOVE BOX BOTTOM MAT_ [INFO](#)
60. SEPARATE CONSOLE BOX ASSEMBLY_ [INFO](#)
61. REMOVE AIR CONDITIONING CONTROL ASSEMBLY_ [INFO](#)
62. REMOVE SHIFT LOCK CONTROL UNIT ASSEMBLY_ [INFO](#)
63. REMOVE UPPER INSTRUMENT PANEL FINISH PANEL ASSEMBLY_ [INFO](#)
64. REMOVE CONSOLE BOX ASSEMBLY_ [INFO](#)
65. REMOVE NO. 1 SWITCH HOLE BASE_ [INFO](#)
66. REMOVE LOWER NO. 3 STEERING WHEEL COVER_ [INFO](#)
67. REMOVE LOWER NO. 2 STEERING WHEEL COVER_ [INFO](#)
68. REMOVE STEERING PAD_ [INFO](#)
69. REMOVE STEERING WHEEL ASSEMBLY_ [INFO](#)
70. REMOVE LOWER STEERING COLUMN COVER_ [INFO](#)
71. REMOVE UPPER STEERING COLUMN COVER_ [INFO](#)
72. REMOVE TURN SIGNAL SWITCH ASSEMBLY WITH SPIRAL CABLE SUB-ASSEMBLY_ [INFO](#)
73. REMOVE NO. 1 INSTRUMENT PANEL UNDER COVER SUB-ASSEMBLY_ [INFO](#)
74. REMOVE DRIVER SIDE KNEE AIRBAG ASSEMBLY_ [INFO](#)
75. REMOVE NO. 2 INSTRUMENT PANEL UNDER COVER SUB-ASSEMBLY_ [INFO](#)
76. REMOVE GLOVE COMPARTMENT DOOR ASSEMBLY_ [INFO](#)
77. REMOVE FRONT DOOR SCUFF PLATE RH

HINT:

Use the same procedure for the RH side and LH side.

78. REMOVE COWL SIDE TRIM BOARD RH

HINT:

Use the same procedure for the RH side and LH side.

79. REMOVE NO. 1 HEATER TO REGISTER DUCT_ [INFO](#)

80. REMOVE COMBINATION METER ASSEMBLY_ [INFO](#)

81. REMOVE POWER STEERING ECU ASSEMBLY (for Brush Type Motor)_ [INFO](#)

82. REMOVE POWER STEERING ECU ASSEMBLY (for Brushless Type Motor)_ [INFO](#)

83. REMOVE INSTRUMENT PANEL SAFETY PAD PLATE SUB-ASSEMBLY (for LHD)_ [INFO](#)

84. REMOVE NO. 2 ANTENNA CORD SUB-ASSEMBLY_ [INFO](#)

85. REMOVE LOWER INSTRUMENT PANEL SUB-ASSEMBLY_ [INFO](#)

86. REMOVE DRIVER SIDE JUNCTION BLOCK ASSEMBLY_ [INFO](#)

87. REMOVE STOP LIGHT SWITCH ASSEMBLY_ [INFO](#)

88. REMOVE STOP LIGHT SWITCH MOUNTING ADJUSTER

89. REMOVE BRAKE PEDAL RETURN SPRING_ [INFO](#)

90. REMOVE PUSH ROD PIN_ [INFO](#)

91. REMOVE BRAKE PEDAL SUPPORT ASSEMBLY_ [INFO](#)

92. REMOVE NO. 2 AIR DUCT SUB-ASSEMBLY_ [INFO](#)

93. REMOVE COLUMN HOLE COVER SILENCER SHEET_ [INFO](#)

94. SEPARATE NO. 2 STEERING INTERMEDIATE SHAFT ASSEMBLY_ [INFO](#)

95. REMOVE STEERING POST ASSEMBLY

for Brush Type Motor: [INFO](#)

for Brushless Type Motor: [INFO](#)

96. REMOVE REAR NO. 2 AIR DUCT (w/ Rear Air Duct)

(a) Disengage each claw to open the 2 door scuff plate clamps as shown in the illustration.

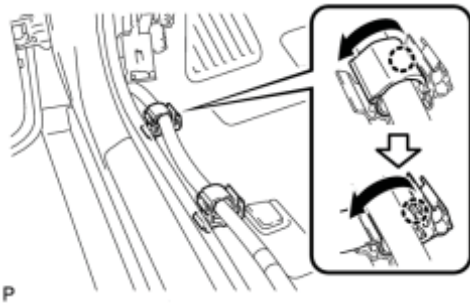

P

(b) Disengage the clip and fastener.

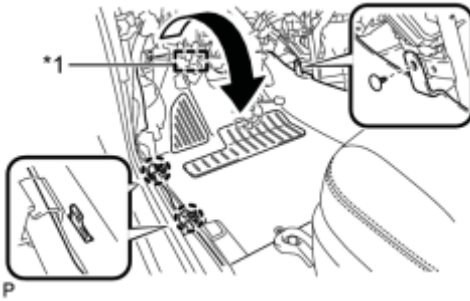

P

(c) Disengage the 2 claws and turn back the floor carpet as shown in the illustration.

Text in Illustration

*1	Fastener
----	----------

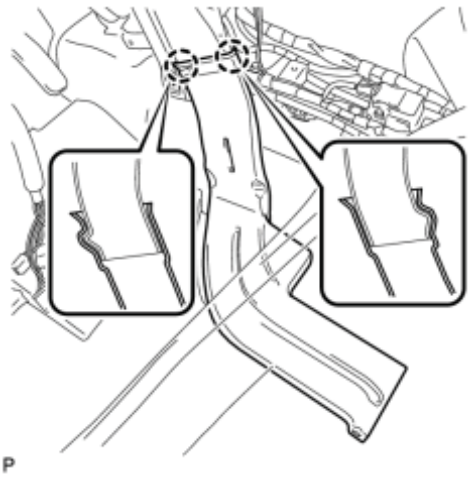

P

(d) Disengage the 2 claws and remove the rear No. 2 air duct.

97. REMOVE REAR NO. 3 AIR DUCT (w/ Rear Air Duct)

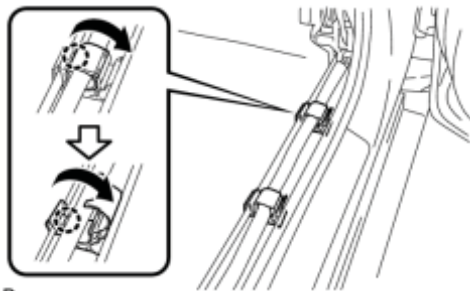

P

(a) Disengage each claw to open the 2 door scuff plate clamps as shown in the illustration.



(b) Disengage the clip and fastener.

(c) Disengage the 2 claws and turn back the floor carpet as shown in the illustration.

Text in Illustration

*1	Fastener
----	----------

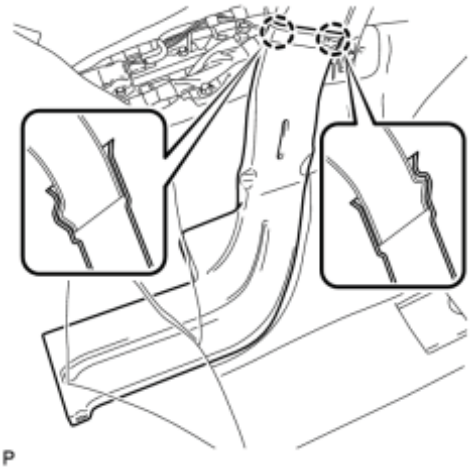

(d) Disengage the 2 claws and remove the rear No. 3 air duct.

98. REMOVE REAR NO. 1 AIR DUCT (w/ Rear Air Duct)

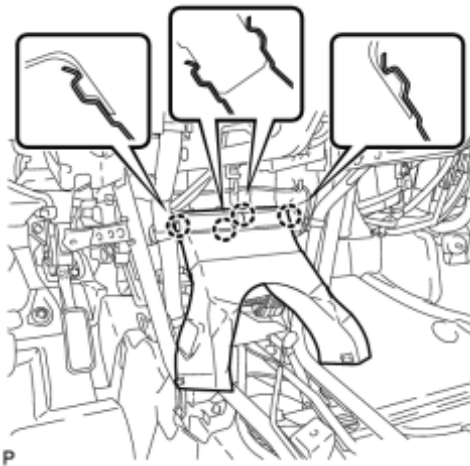

(a) Disengage the 4 claws and remove the rear No. 1 air duct.

99. REMOVE NO. 3 SIDE DEFROSTER NOZZLE DUCT

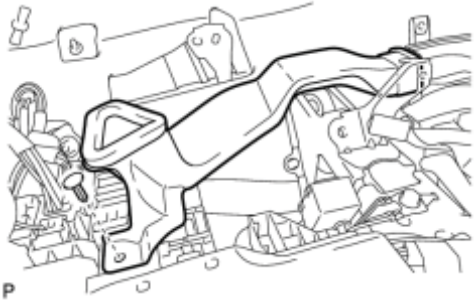

(a) Remove the clip and No. 3 side defroster nozzle duct.

100. REMOVE NO. 1 INSTRUMENT PANEL BRACE SUB-ASSEMBLY

- (a) Check that the power switch is off.
- (b) Check that the cable is disconnected from the negative (-) battery terminal.

CAUTION:

Wait at least 90 seconds after disconnecting the cable from the negative (-) battery terminal to disable the SRS system.

- (c) Disconnect the center airbag sensor connectors from the center airbag sensor assembly as shown in the illustration.

NOTICE:

When disconnecting any airbag connector, take care not to damage the airbag wire harness.

- (d) Remove the screw.
- (e) Remove the 2 bolts and disconnect the 2 earth wires.
- (f) Disconnect each connector.
- (g) Disengage each clamp and claw.

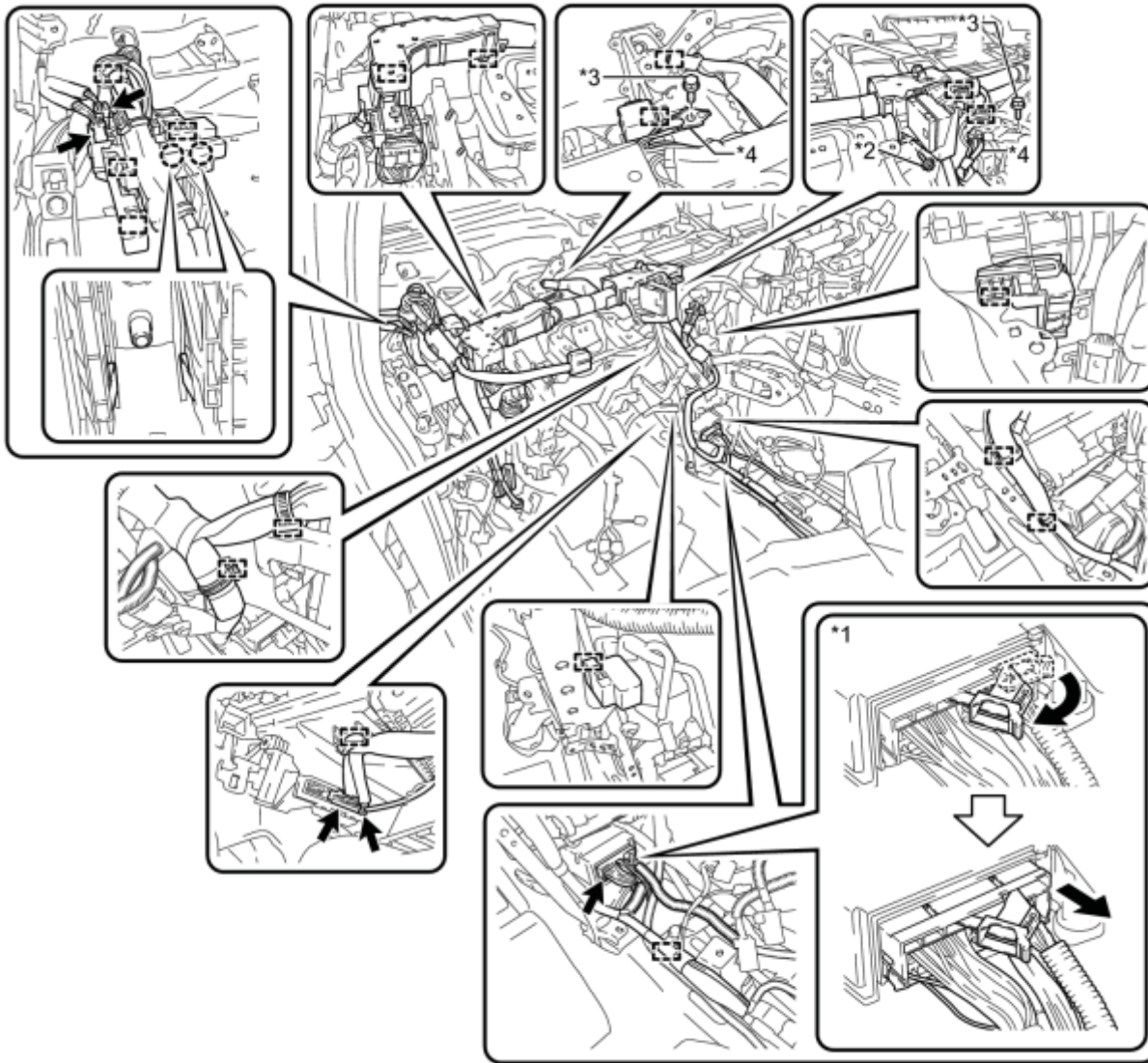

P

Text in Illustration

*1	Center Airbag Sensor Connector	*2	Screw
*3	Bolt	*4	Earth Wire

(h) Remove the screw.

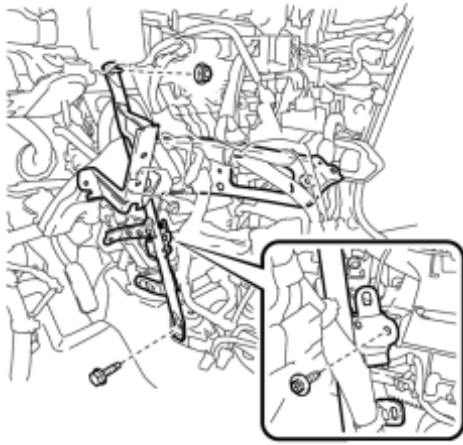

P

(i) Remove the bolt, nut and No. 1 instrument panel brace sub-assembly.

101. REMOVE NO. 2 INSTRUMENT PANEL BRACE SUB-ASSEMBLY

(a) Remove the 3 screws <A>.

(b) Remove the bolt and disconnect the earth wire.

(c) Disconnect each connector.

(d) Disengage each clamp.

(e) Remove the screw and 2 nuts from the computer integration box RH.

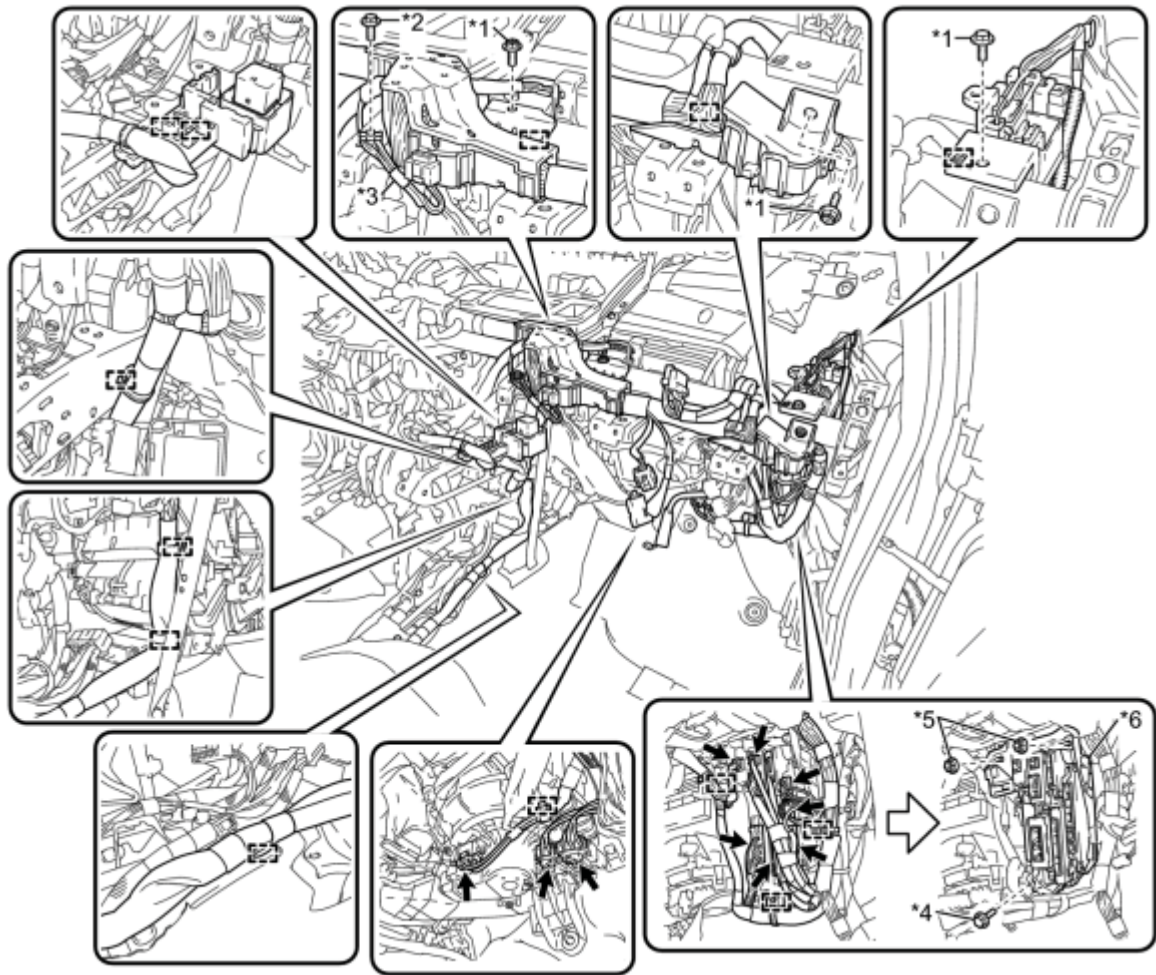

P

Text in Illustration

*1	Screw <A>	*2	Bolt
*3	Earth Wire	*4	Screw
*5	Nut	*6	Computer Integration Box RH

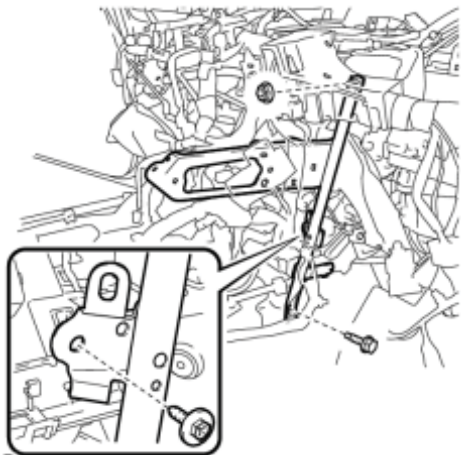

P

(f) Remove the screw.

(g) Remove the bolt, nut and No. 2 instrument panel brace sub-assembly.

102. REMOVE DEFROSTER NOZZLE ASSEMBLY

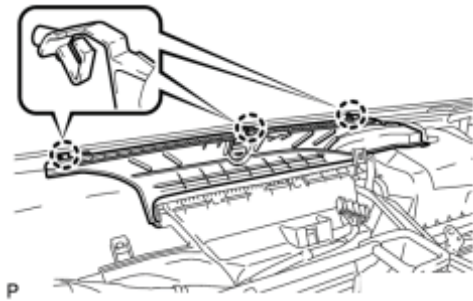

(a) Disengage the 3 claws.

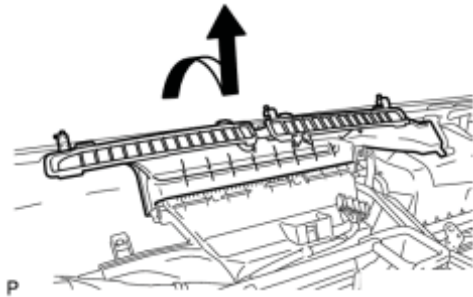

(b) Remove the defroster nozzle assembly as shown in the illustration.

103. REMOVE LOWER DEFROSTER NOZZLE ASSEMBLY

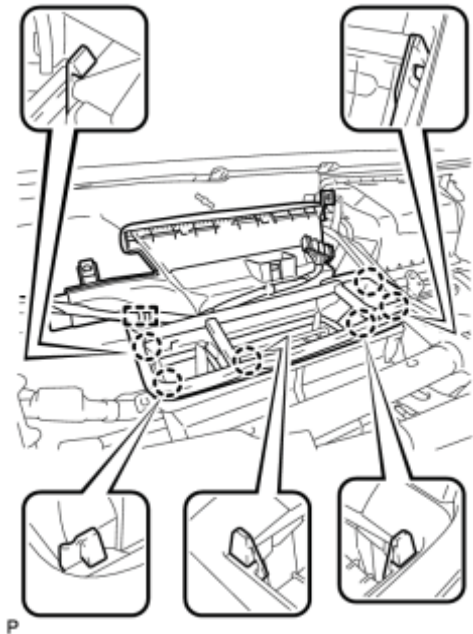

(a) Disengage the clamp.

(b) Disengage the 6 claws and remove the lower defroster nozzle assembly.

104. REMOVE NO. 3 AIR DUCT SUB-ASSEMBLY

(a) Remove the 2 nuts and No. 3 air duct sub-assembly.

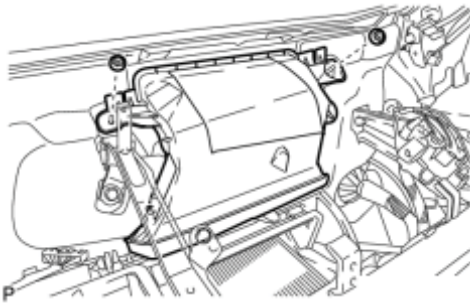

105. REMOVE INSTRUMENT PANEL REINFORCEMENT ASSEMBLY

(a) Disengage each clamp.

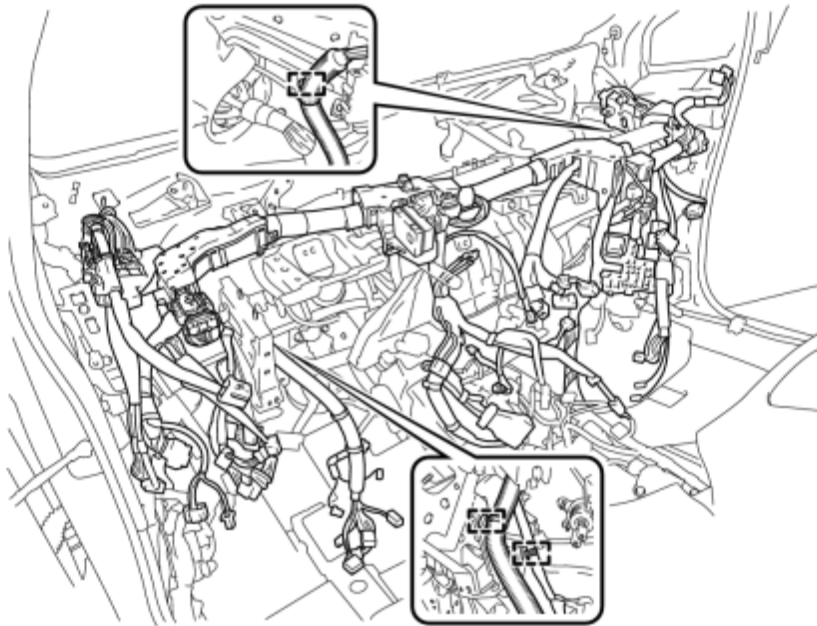

(b) Remove the 9 bolts and instrument panel reinforcement assembly.

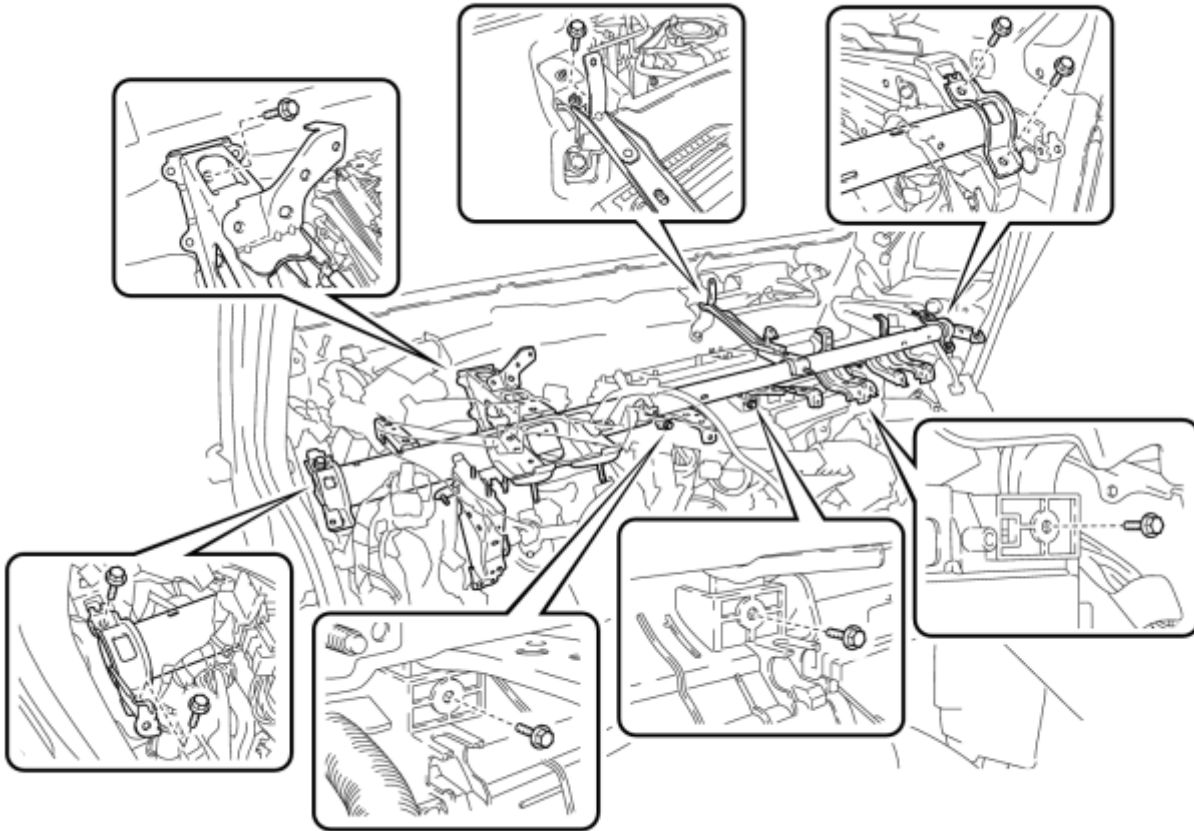

P

106. REMOVE AIR CONDITIONING UNIT ASSEMBLY

NOTICE:

- Be sure to support the air conditioning unit assembly when removing it because failure to do so may cause the bracket of the air conditioning unit assembly to break.
- When disassembling the air conditioning unit, eliminate static electricity by touching the vehicle body to prevent the components from being damaged.

(a) Disengage the cooler drain hose.

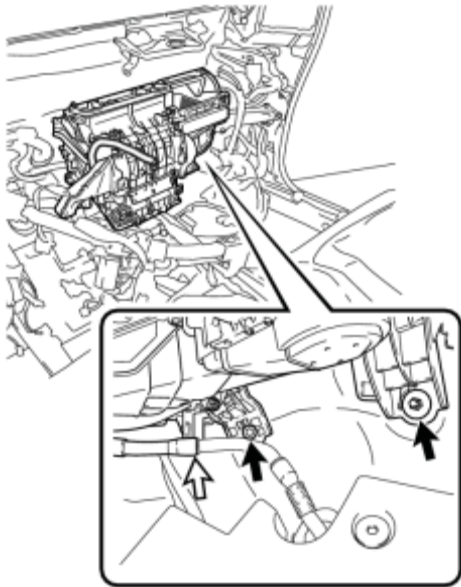

P

(b) Remove the bolt, nut and air conditioning unit assembly.

DISASSEMBLY

1. REMOVE ID CODE BOX (IMMOBILISER CODE ECU) (w/ Engine Immobiliser System) INFO

2. REMOVE BLOWER ASSEMBLY INFO

3. REMOVE NO. 1 AIR DUCT SUB-ASSEMBLY

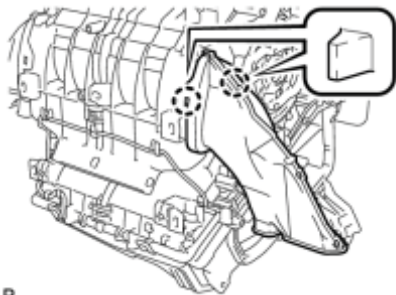

(a) Disengage the 2 claws and remove the No. 1 air duct sub-assembly.

P

4. REMOVE AIR CONDITIONING DUCT SUB-ASSEMBLY

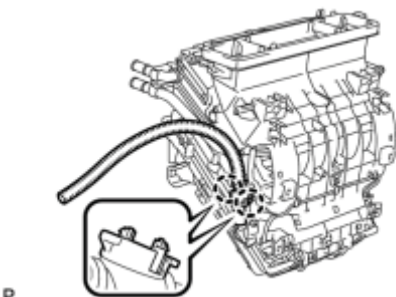

(a) Disengage the 2 claws and remove the air conditioning duct sub-assembly.

P

5. REMOVE AIR CONDITIONING HARNESS ASSEMBLY

(a) Disconnect each connector.

(b) Disengage each clamp and remove the air conditioning harness assembly.

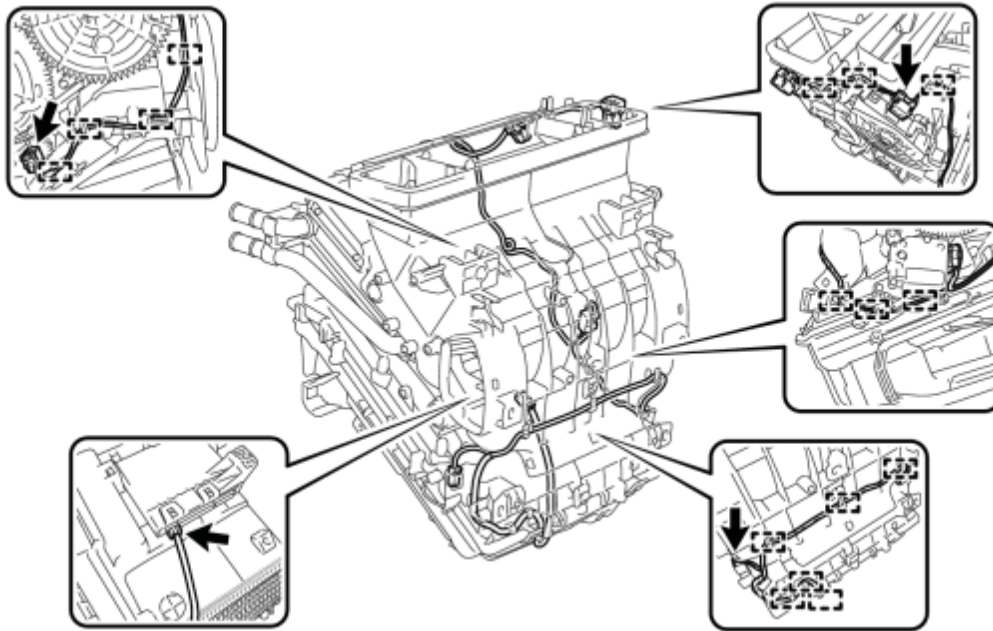

6. REMOVE AIR OUTLET CONTROL SERVO MOTOR SUB-ASSEMBLY

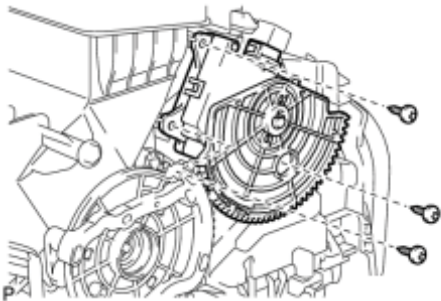

(a) Remove the 3 screws and air outlet control servo motor sub-assembly.

7. REMOVE AIR MIX CONTROL SERVO MOTOR SUB-ASSEMBLY

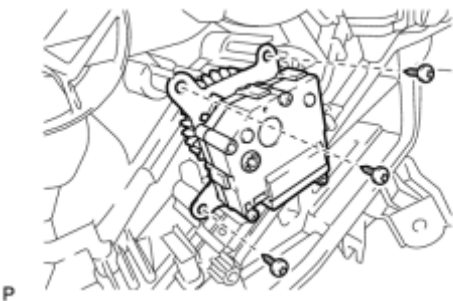

(a) Remove the 3 screws and air mix control servo motor sub-assembly.

8. REMOVE QUICK HEATER ASSEMBLY

(a) Disengage each clamp.

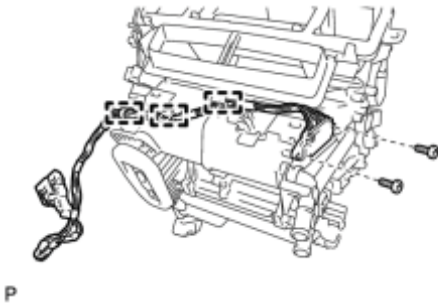

(b) Remove the 2 screws.

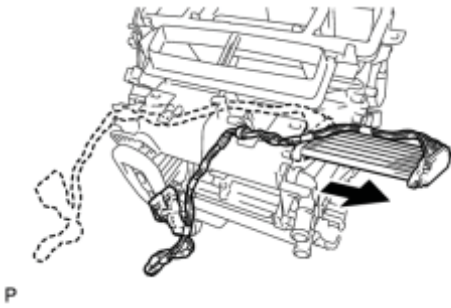

(c) Remove the quick heater assembly as shown in the illustration.

9. REMOVE HEATER RADIATOR UNIT SUB-ASSEMBLY

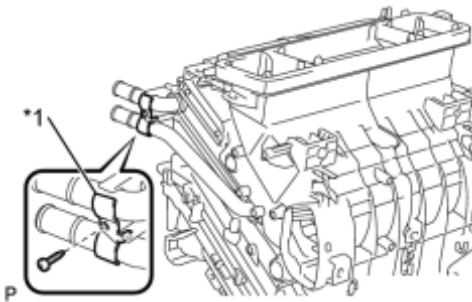

(a) Remove the screw and clamp.

Text in Illustration

*1	Clamp
----	-------

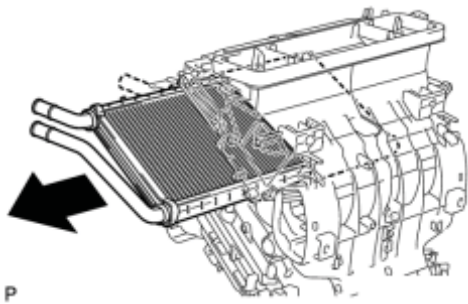

(b) Remove the heater radiator unit sub-assembly as shown in the illustration.

NOTICE:

Prepare a drain pan or cloth in case the cooling water leaks.

10. REMOVE CONSOLE MOUNTING BRACKET LH

(a) Remove the screw and console mounting bracket LH.

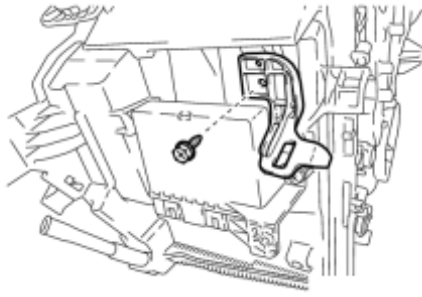

P

11. REMOVE AIR CONDITIONING AMPLIFIER ASSEMBLY

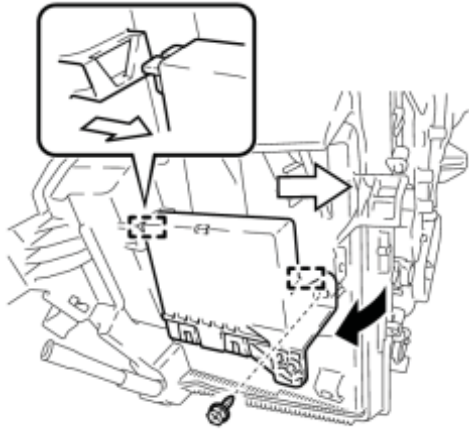

P

(a) Remove the screw.

(b) Disengage the 2 guides and remove the air conditioning amplifier assembly as shown in the illustration.

12. REMOVE CONSOLE MOUNTING BRACKET RH

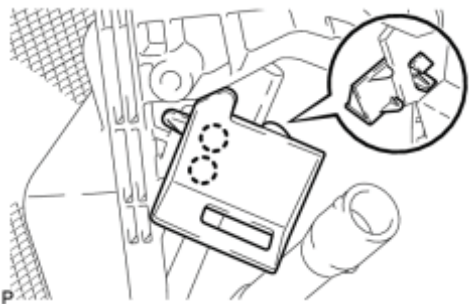

P

(a) Disengage the 2 claws and remove the console mounting bracket RH.

13. REMOVE DRAIN COOLER HOSE

(a) Remove the drain cooler hose as shown in the illustration.

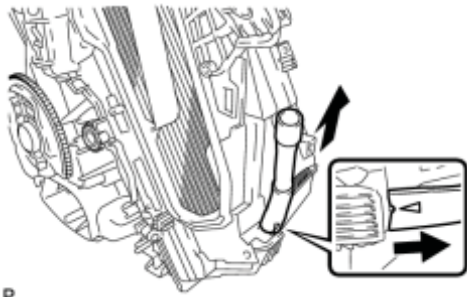

14. REMOVE COOLER EXPANSION VALVE

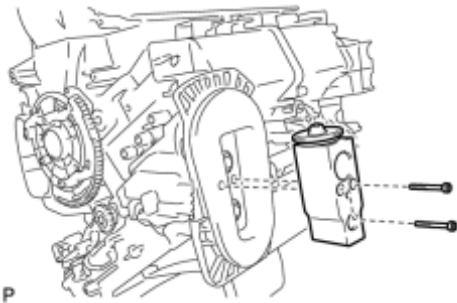

(a) Using a 4 mm hexagon wrench, remove the 2 hexagon bolts and cooler expansion valve.

15. REMOVE COOLER EVAPORATOR SUB-ASSEMBLY

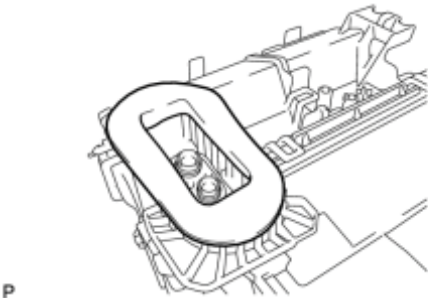

(a) Remove the packing.

NOTICE:

Remove the packing carefully because it will be reused.

(b) Remove the 4 screws.

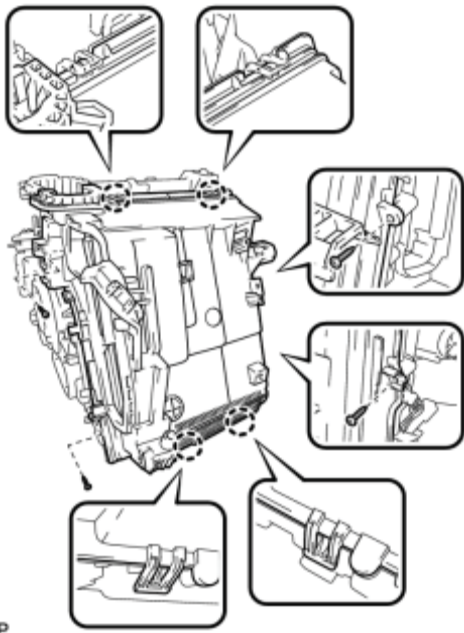

P

(c) Disengage the 4 claws and remove the lower heater case.

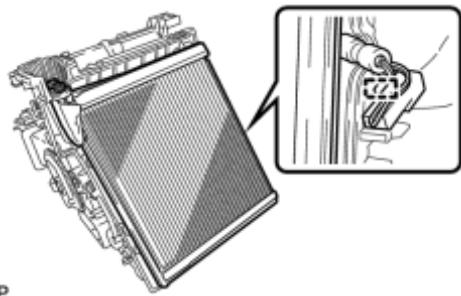

P

(d) Disengage the clamp and remove the cooler evaporator sub-assembly with the No. 1 cooler thermistor.

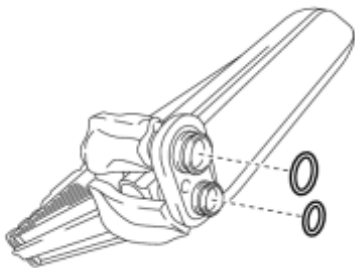

P

(e) Remove the 2 O-rings from the cooler evaporator sub-assembly.

16. REMOVE NO. 1 COOLER THERMISTOR_ INFO

REASSEMBLY

1. INSTALL NO. 1 COOLER THERMISTOR_ INFO

2. INSTALL COOLER EVAPORATOR SUB-ASSEMBLY

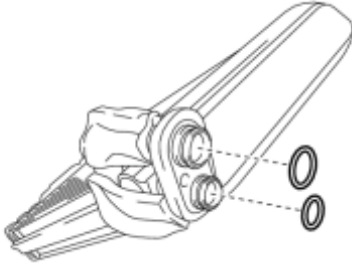

P

(a) Sufficiently apply compressor oil to 2 new O-rings and the fitting surfaces.

Compressor oil:

ND-OIL 11 or equivalent

(b) Install the 2 O-rings to the cooler evaporator sub-assembly.

NOTICE:

- Keep the O-rings and O-ring fitting surfaces free from dirt or any foreign objects.
- Do not use any compressor oil other than ND-OIL 11 or equivalent. If any compressor oil other than ND-OIL 11 or equivalent is used, compressor motor insulation performance may decrease, resulting in a leakage of electric power.

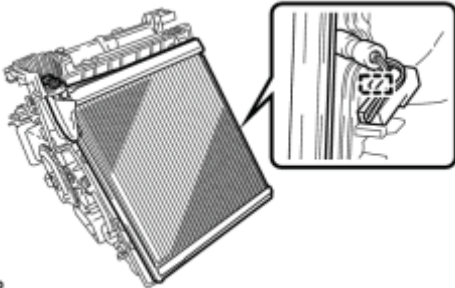

P

(c) Engage the clamp and install the cooler evaporator sub-assembly with the No. 1 cooler thermistor.

HINT:

Completely cover the tube with the grommet.

(d) Engage the 4 claws.

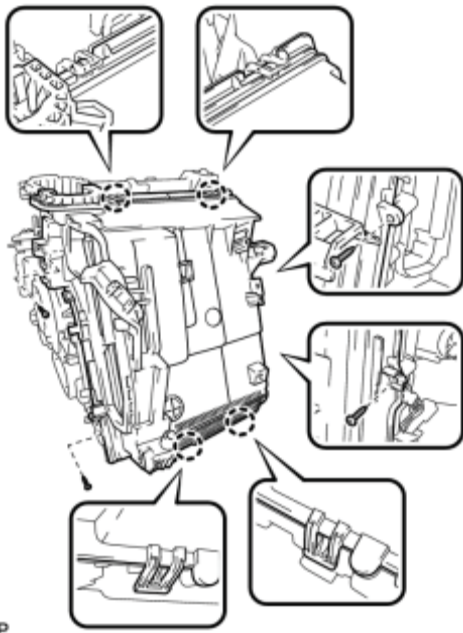

P

(e) Install the lower heater case with the 4 screws.

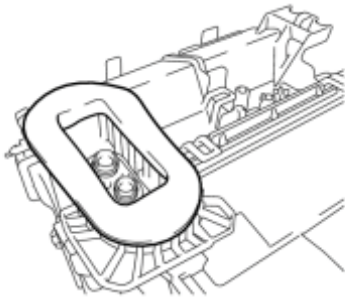

P

(f) Install the packing.

3. INSTALL COOLER EXPANSION VALVE

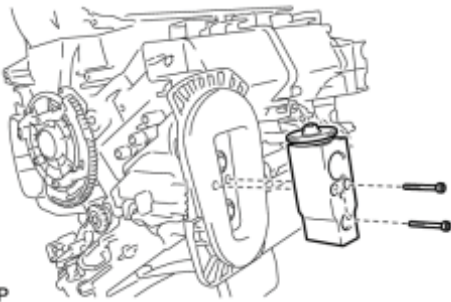

P

(a) Using a 4 mm hexagon wrench, install the cooler expansion valve with the 2 hexagon bolts.

Torque: **3.5 N·m (36 kgf·cm, 31 in·lbf)**

4. INSTALL DRAIN COOLER HOSE

(a) Install the drain cooler hose as shown in the illustration.

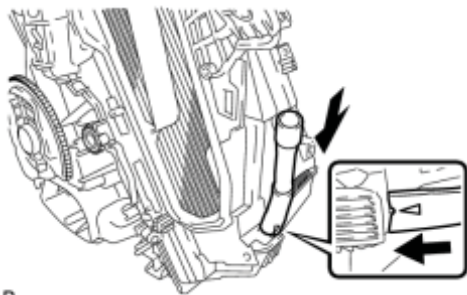

P

5. INSTALL CONSOLE MOUNTING BRACKET RH



P

(a) Engage the 2 claws and install the console mounting bracket RH.

6. INSTALL AIR CONDITIONING AMPLIFIER ASSEMBLY

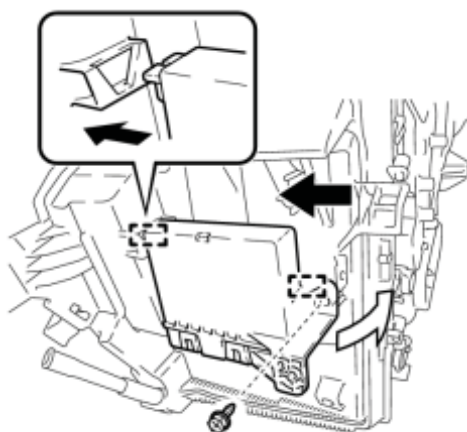

P

(a) Engage the 2 guides to install the air conditioning amplifier assembly as shown in the illustration.

(b) Install the screw.

7. INSTALL CONSOLE MOUNTING BRACKET LH

(a) Install the console mounting bracket LH with the screw.

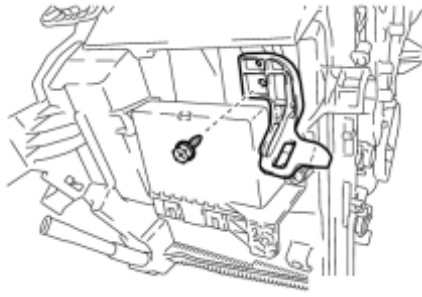

P

8. INSTALL HEATER RADIATOR UNIT SUB-ASSEMBLY

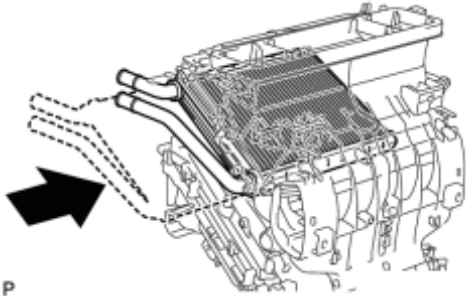

P

(a) Install the heater radiator unit sub-assembly as shown in the illustration.

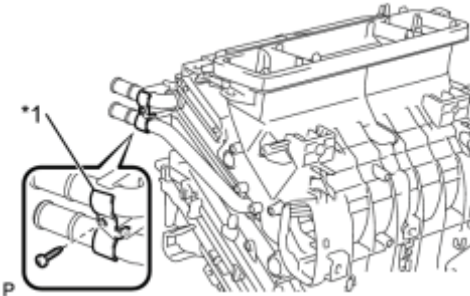

P

(b) Install the clamp with the screw.

Text in Illustration

*1	Clamp
----	-------

9. INSTALL QUICK HEATER ASSEMBLY

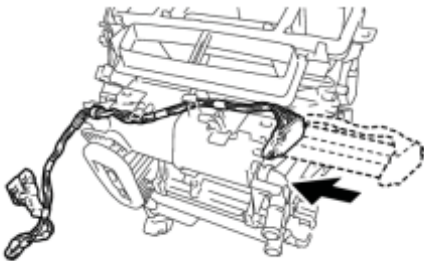

P

(a) Install the quick heater assembly as shown in the illustration.

(b) Install the 2 screws.

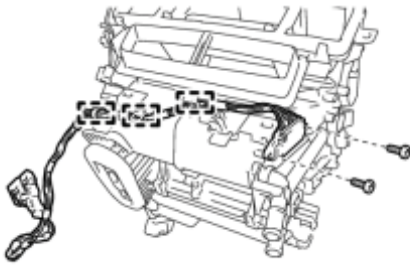

P

(c) Engage each clamp.

10. INSTALL AIR MIX CONTROL SERVO MOTOR SUB-ASSEMBLY

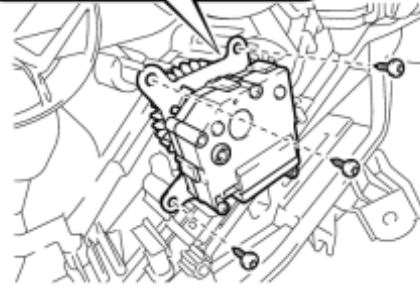
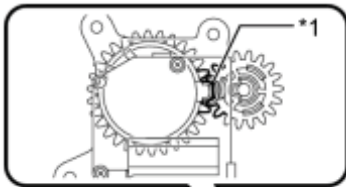

P

(a) Using the reference point, install the air mix control servo motor sub-assembly with the 3 screws.

Text in Illustration

*1	Reference Point
----	-----------------

11. INSTALL AIR OUTLET CONTROL SERVO MOTOR SUB-ASSEMBLY

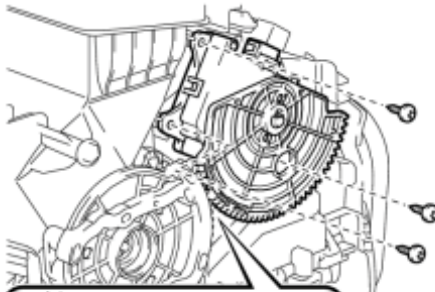

P

(a) Using the reference point, install the air outlet control servo motor sub-assembly with the 3 screws.

Text in Illustration

*1	Reference Point
----	-----------------

12. INSTALL AIR CONDITIONING HARNESS ASSEMBLY

(a) Connect each connector.

(b) Engage each clamp to install the air conditioning harness assembly.

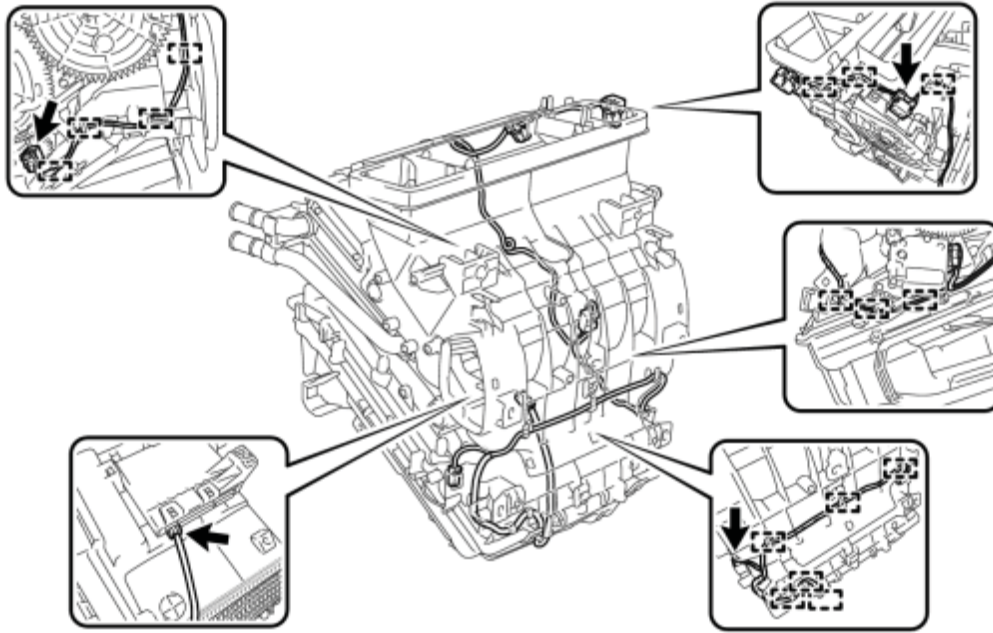

P

13. INSTALL AIR CONDITIONING DUCT SUB-ASSEMBLY

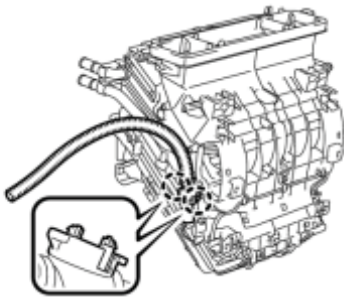

P

(a) Engage the 2 claws and install the air conditioning duct sub-assembly.

14. INSTALL NO. 1 AIR DUCT SUB-ASSEMBLY

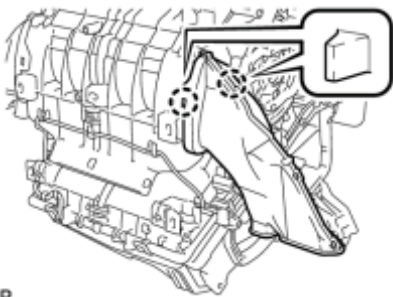

P

15. INSTALL BLOWER ASSEMBLY_ INFO

16. INSTALL ID CODE BOX (IMMOBILISER CODE ECU) (w/ Engine Immobiliser System)_ INFO

INSTALLATION

1. TEMPORARILY TIGHTEN AIR CONDITIONING UNIT ASSEMBLY

NOTICE:

- Be sure to support the air conditioning unit assembly when removing it because failure to do so may cause the bracket of the air conditioning unit assembly to break.
- When installing the air conditioning unit, eliminate static electricity by touching the vehicle body to prevent the components from being damaged.

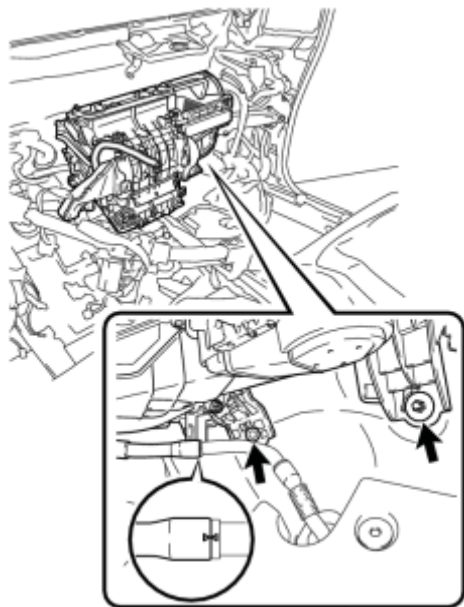

(a) Temporarily tighten the air conditioning unit assembly with the bolt and nut.

P

(b) Engage the cooler drain hose as shown in the illustration.

NOTICE:

Connect the cooler drain hose firmly to prevent water leaks.

2. INSTALL INSTRUMENT PANEL REINFORCEMENT ASSEMBLY

(a) Install the instrument panel reinforcement assembly with the 6 bolts <A>.

(b) Install the air conditioning unit assembly with the 3 bolts

Bolt - Torque: **9.8 N·m (100 kgf·cm, 87in·lbf)**

HINT:

Tighten the bolts in the order shown in the illustration.

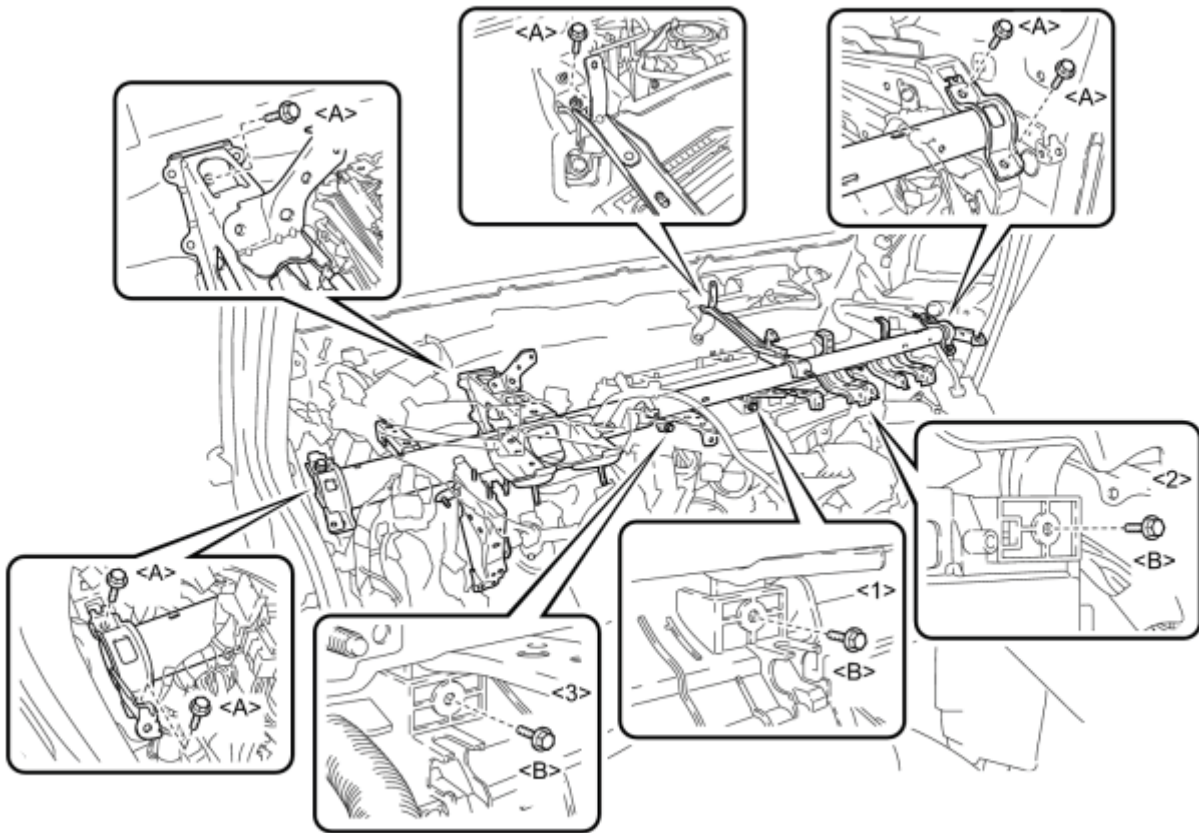

P

(c) Engage each clamp.

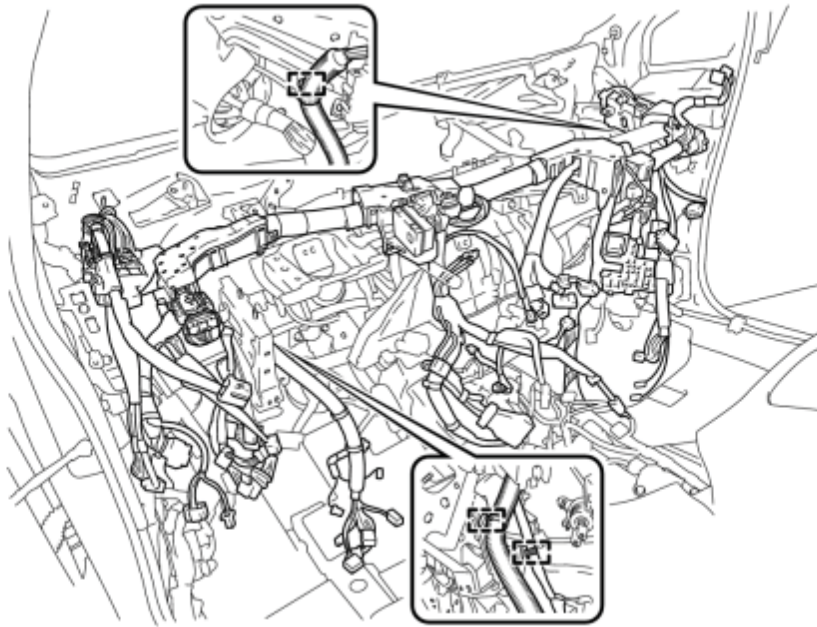

P

3. INSTALL AIR CONDITIONING UNIT ASSEMBLY

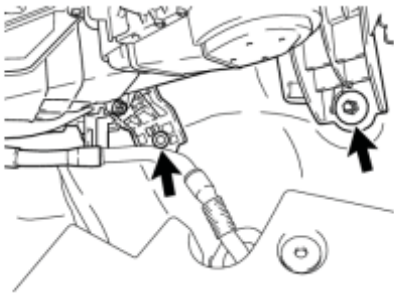

P

(a) Install the air conditioning unit assembly with the bolt and nut.

Bolt - Torque: **9.8 N·m (100 kgf·cm, 87in·lbf)**

Nut - Torque: **9.8 N·m (100 kgf·cm, 87in·lbf)**

4. INSTALL NO. 3 AIR DUCT SUB-ASSEMBLY

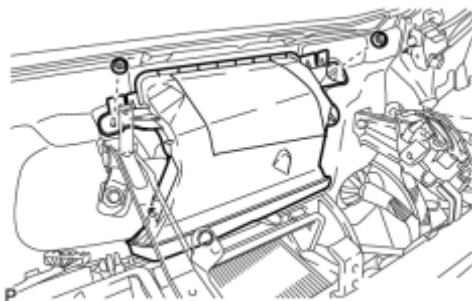

P

(a) Install the No. 3 air duct sub-assembly with the 2 nuts.

Torque: **9.8 N·m (100 kgf·cm, 87in·lbf)**

5. INSTALL LOWER DEFROSTER NOZZLE ASSEMBLY

(a) Engage the 6 claws and remove the lower defroster nozzle assembly.

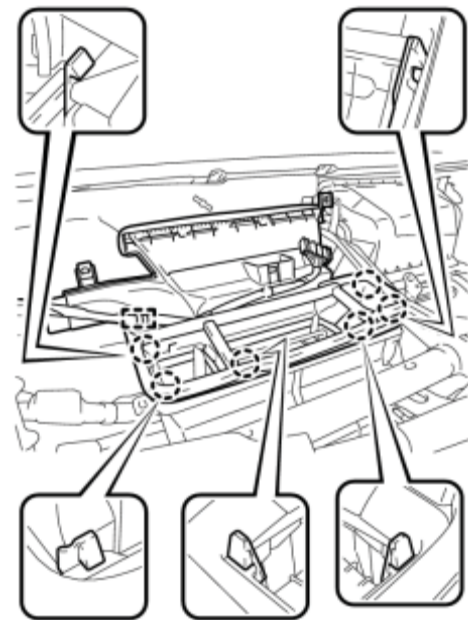

P

(b) Engage the clamp.

6. INSTALL DEFROSTER NOZZLE ASSEMBLY

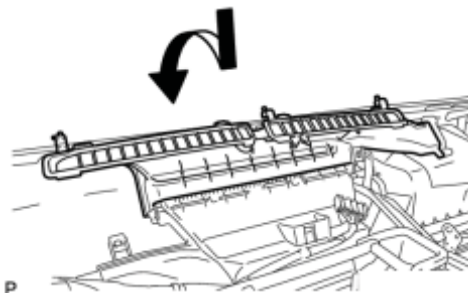

P

(a) Install the defroster nozzle assembly as shown in the illustration.

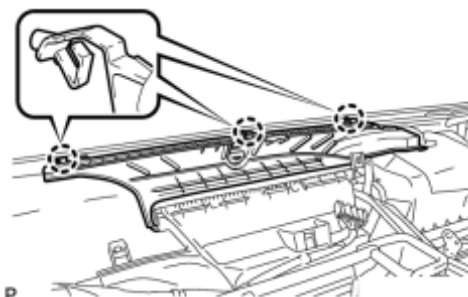

P

(b) Engage the 3 claws.

7. INSTALL NO. 2 INSTRUMENT PANEL BRACE SUB-ASSEMBLY

(a) Install the No. 2 instrument panel brace sub-assembly with the screw.

Torque: **4.0 N·m (41 kgf·cm, 35in·lbf)**

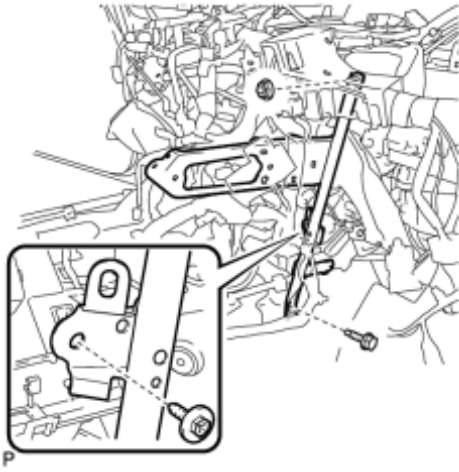

- (b) Install the bolt and nut.
- (c) Install the screw and 2 nuts to the computer integration box RH.
- (d) Engage each clamp.
- (e) Connect each connector.
- (f) Install the 3 screws <A>.
- (g) Install the bolt and connect the earth wire.

Torque: **8.4 N·m (86 kgf·cm, 74in·lbf)**

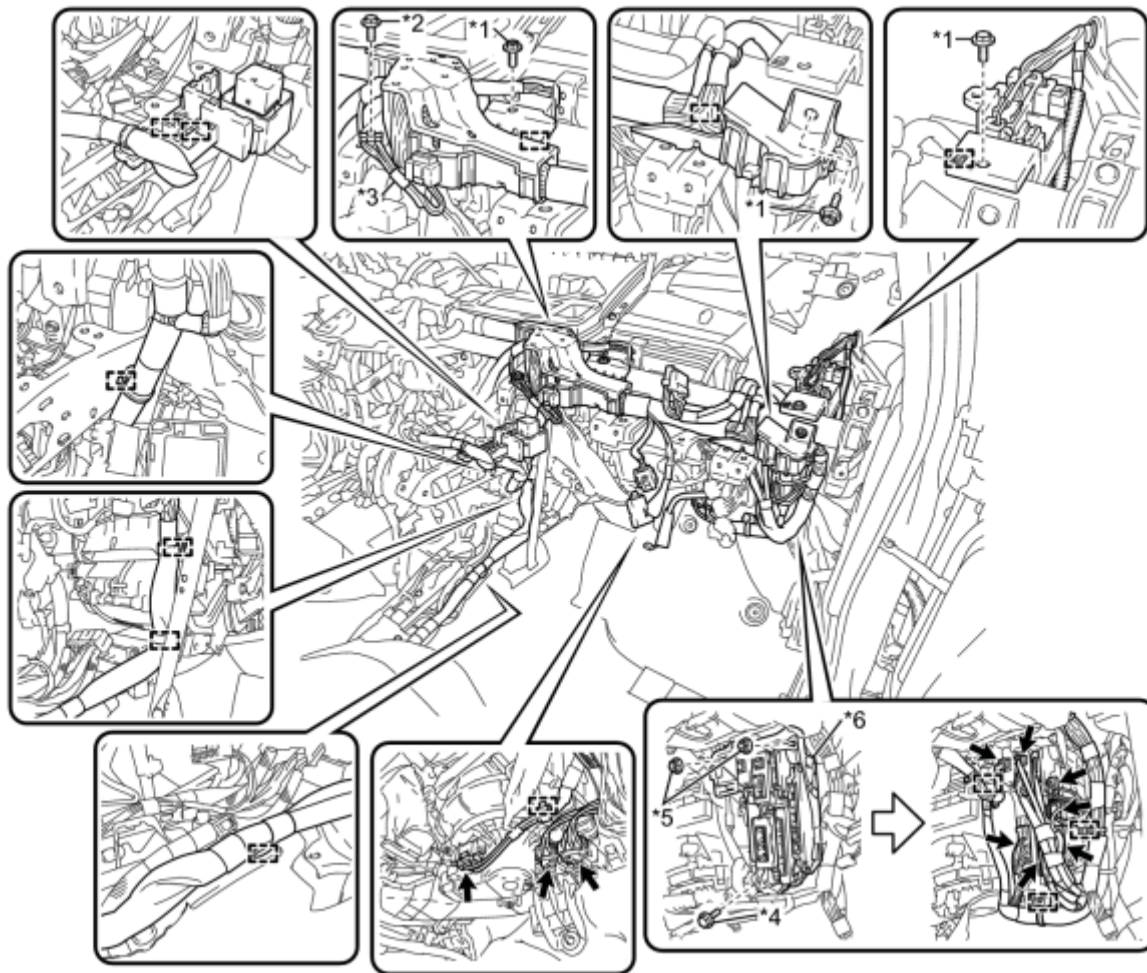

P

Text in Illustration

*1	Screw <A>	*2	Bolt
*3	Earth Wire	*4	Screw
*5	Nut	*6	Computer Integration Box RH

8. INSTALL NO. 1 INSTRUMENT PANEL BRACE SUB-ASSEMBLY

(a) Install the No. 1 instrument panel brace sub-assembly with the screw.

Torque: 4.0 N·m (41 kgf·cm, 35in·lbf)

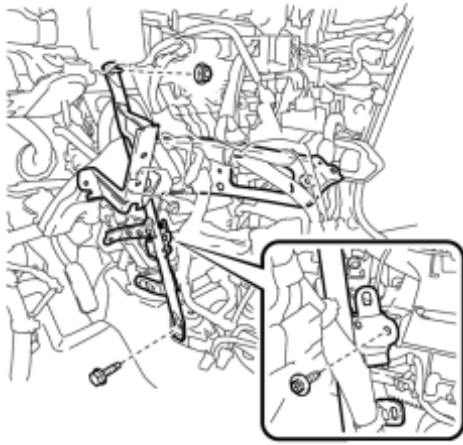

P

- (b) Install the bolt and nut.
- (c) Check that the power switch is off.
- (d) Check that the cable is disconnected from the negative (-) battery terminal.

CAUTION:

Wait at least 90 seconds after disconnecting the cable from the negative (-) battery terminal to disable the SRS system.

- (e) Connect the center airbag sensor connectors to the center airbag sensor assembly as shown in the illustration.

NOTICE:

When connecting any airbag connector, take care not to damage the airbag wire harness.

- (f) Check that the waterproof sheet on the top of the center airbag sensor is not folded or deformed.
- (g) Check that there is no looseness in the installation parts of the center airbag sensor assembly.
- (h) Connect each connector.
- (i) Engage each clamp and claw.
- (j) Install the screw.
- (k) Install the 2 bolts and connect the 2 earth wires.

Torque: **8.4 N·m (86 kgf·cm, 74in·lbf)**

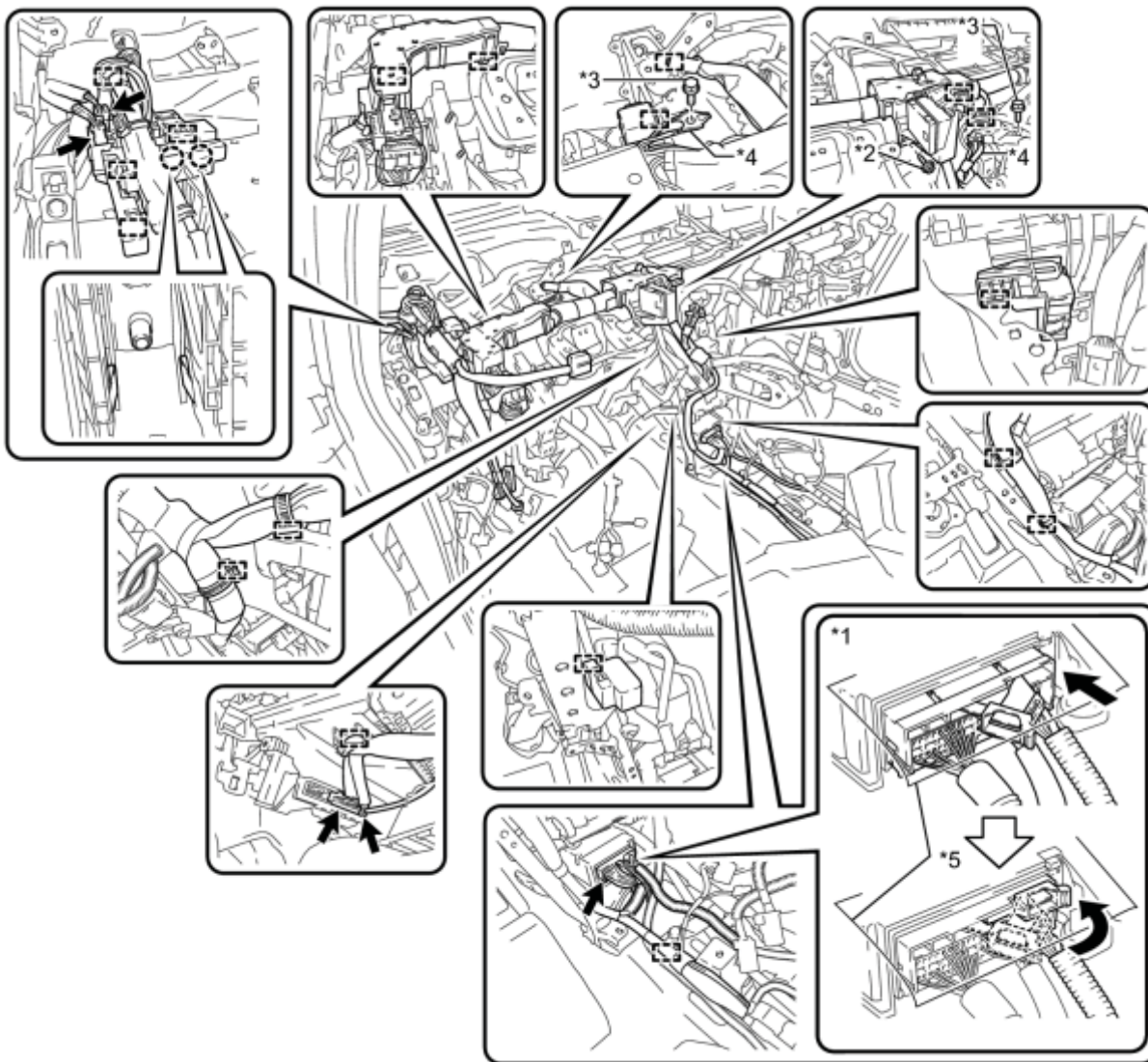

P

Text in Illustration

*1	Center Airbag Sensor Connector	*2	Screw
*3	Bolt	*4	Earth Wire
*5	Waterproof Sheet	-	-

9. INSTALL NO. 3 SIDE DEFROSTER NOZZLE DUCT

(a) Install the No. 3 side defroster nozzle duct with the clip.

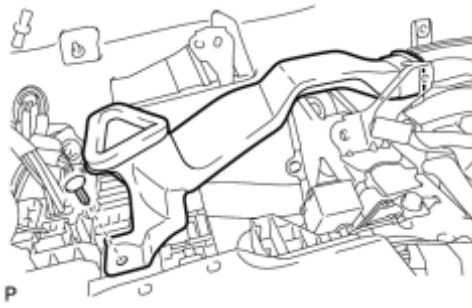

10. INSTALL REAR NO. 1 AIR DUCT (w/ Rear Air Duct)

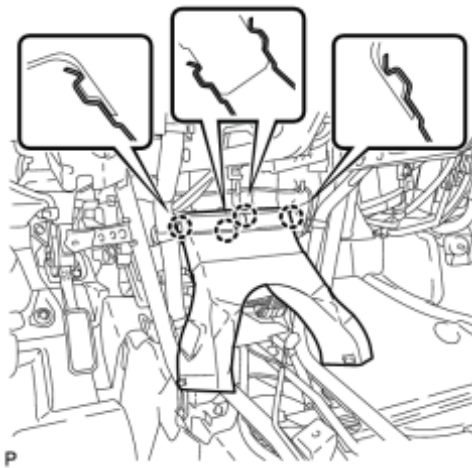

11. INSTALL REAR NO. 3 AIR DUCT (w/ Rear Air Duct)

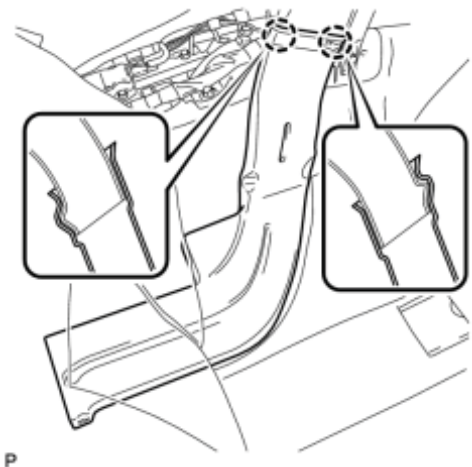

(b) Engage the 2 claws and install the clip.



(c) Engage the fastener to install the floor carpet to the original position.

Text in Illustration

*1	Fastener
----	----------

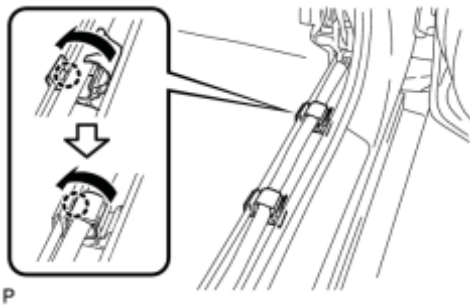

(d) Engage each claw to close the door scuff plate clamps as shown in the illustration.

12. INSTALL REAR NO. 2 AIR DUCT (w/ Rear Air Duct)

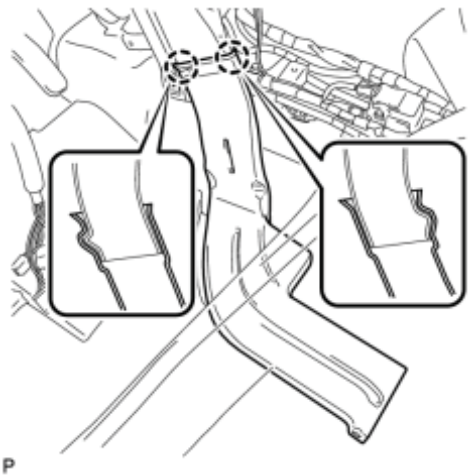

(a) Engage the 2 claws to install the rear No. 2 air duct.

(b) Engage the 2 claws and install the clip.

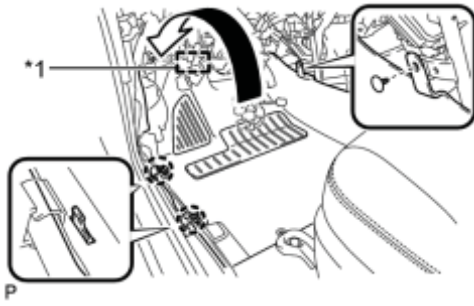

(c) Engage the fastener to install the floor carpet to the original position as shown in the illustration.

Text in Illustration

*1	Fastener
----	----------

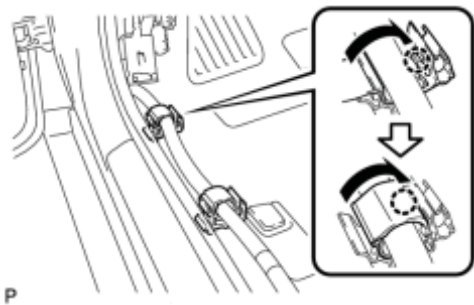

(d) Engage each claw to close the door scuff plate clamps as shown in the illustration.

13. INSTALL STEERING POST ASSEMBLY

for Brush Type Motor: [INFO](#)

for Brushless Type Motor: [INFO](#)

14. CONNECT NO. 2 STEERING INTERMEDIATE SHAFT ASSEMBLY_ [INFO](#)

15. INSTALL COLUMN HOLE COVER SILENCER SHEET_ [INFO](#)

16. INSTALL NO. 2 AIR DUCT SUB-ASSEMBLY_ [INFO](#)

17. INSTALL BRAKE PEDAL SUPPORT ASSEMBLY_ [INFO](#)

18. INSTALL PUSH ROD PIN_ [INFO](#)

19. INSTALL BRAKE PEDAL RETURN SPRING_ [INFO](#)

20. INSTALL STOP LIGHT SWITCH MOUNTING ADJUSTER

21. INSTALL STOP LIGHT SWITCH ASSEMBLY_ [INFO](#)

22. INSTALL DRIVER SIDE JUNCTION BLOCK ASSEMBLY_ [INFO](#)

23. INSTALL LOWER INSTRUMENT PANEL SUB-ASSEMBLY_ [INFO](#)
24. INSTALL NO. 2 ANTENNA CORD SUB-ASSEMBLY_ [INFO](#)
25. INSTALL INSTRUMENT PANEL SAFETY PAD PLATE SUB-ASSEMBLY (for LHD)_ [INFO](#)
26. INSTALL POWER STEERING ECU ASSEMBLY (for Brush Type Motor)_ [INFO](#)
27. INSTALL POWER STEERING ECU ASSEMBLY (for Brushless Type Motor)_ [INFO](#)
28. INSTALL COMBINATION METER ASSEMBLY_ [INFO](#)
29. INSTALL NO. 1 HEATER TO REGISTER DUCT_ [INFO](#)
30. INSTALL COWL SIDE TRIM BOARD RH

HINT:

Use the same procedure for the RH side and LH side.

31. INSTALL FRONT DOOR SCUFF PLATE RH

HINT:

Use the same procedure for the RH side and LH side.

32. INSTALL GLOVE COMPARTMENT DOOR ASSEMBLY_ [INFO](#)
33. INSTALL NO. 2 INSTRUMENT PANEL UNDER COVER SUB-ASSEMBLY_ [INFO](#)
34. INSTALL DRIVER SIDE KNEE AIRBAG ASSEMBLY_ [INFO](#)
35. INSTALL NO. 1 INSTRUMENT PANEL UNDER COVER SUB-ASSEMBLY_ [INFO](#)
36. ALIGN FRONT WHEELS FACING STRAIGHT AHEAD
37. INSTALL TURN SIGNAL SWITCH ASSEMBLY WITH SPIRAL CABLE SUB-ASSEMBLY_ [INFO](#)
38. INSTALL UPPER STEERING COLUMN COVER_ [INFO](#)
39. INSTALL LOWER STEERING COLUMN COVER_ [INFO](#)
40. INSTALL STEERING WHEEL ASSEMBLY_ [INFO](#)
41. INSTALL STEERING PAD_ [INFO](#)
42. INSTALL LOWER NO. 3 STEERING WHEEL COVER_ [INFO](#)
43. INSTALL LOWER NO. 2 STEERING WHEEL COVER_ [INFO](#)

44. INSTALL NO. 1 SWITCH HOLE BASE_ [INFO](#)
45. INSTALL UPPER INSTRUMENT PANEL FINISH PANEL ASSEMBLY_ [INFO](#)
46. INSTALL SHIFT LOCK CONTROL UNIT ASSEMBLY_ [INFO](#)
47. INSTALL AIR CONDITIONING CONTROL ASSEMBLY_ [INFO](#)
48. INSTALL CONSOLE BOX ASSEMBLY_ [INFO](#)
49. INSTALL BOX BOTTOM MAT_ [INFO](#)
50. INSTALL FRONT NO. 2 CONSOLE BOX INSERT_ [INFO](#)
51. INSTALL FRONT NO. 1 CONSOLE BOX INSERT_ [INFO](#)
52. INSTALL NO. 2 CONSOLE BOX MOUNTING BRACKET_ [INFO](#)
53. INSTALL ELECTRICAL KEY OSCILLATOR_ [INFO](#)
54. INSTALL REAR CONSOLE BOX ASSEMBLY (w/ Power Outlet Socket)_ [INFO](#)
55. INSTALL REAR CONSOLE BOX ASSEMBLY (w/o Power Outlet Socket)_ [INFO](#)
56. INSTALL CONSOLE BOX CARPET_ [INFO](#)
57. INSTALL UPPER CONSOLE PANEL (w/ Power Outlet Socket)_ [INFO](#)
58. INSTALL REAR CONSOLE BOX POCKET (w/ Power Outlet Socket)_ [INFO](#)
59. INSTALL UPPER INSTRUMENT PANEL ASSEMBLY_ [INFO](#)
60. CONNECT INSTRUMENT PANEL WIRE_ [INFO](#)
61. INSTALL CENTER INSTRUMENT CLUSTER FINISH PANEL GARNISH_ [INFO](#)
62. INSTALL FRONT NO. 2 SPEAKER ASSEMBLY

HINT:

Use the same procedure for the RH side and LH side.

63. INSTALL NO. 2 INSTRUMENT PANEL SPEAKER PANEL SUB-ASSEMBLY_ [INFO](#)
64. INSTALL FRONT PILLAR GARNISH CORNER PIECE RH_ [INFO](#)
65. INSTALL FRONT PILLAR GARNISH RH

HINT:

Use the same procedure for the RH side and LH side.

66. INSTALL FRONT NO. 2 SPEAKER ASSEMBLY_ [INFO](#)
67. INSTALL NO. 1 INSTRUMENT PANEL SPEAKER PANEL SUB-ASSEMBLY_ [INFO](#)
68. INSTALL FRONT PILLAR GARNISH CORNER PIECE LH_ [INFO](#)
69. INSTALL FRONT PILLAR GARNISH LH_ [INFO](#)
70. INSTALL INSTRUMENT PANEL FINISH PANEL END RH_ [INFO](#)
71. CONNECT FRONT DOOR OPENING TRIM WEATHERSTRIP RH_ [INFO](#)
72. INSTALL GLOVE COMPARTMENT DOOR_ [INFO](#)
73. INSTALL NO. 2 INSTRUMENT PANEL REGISTER_ [INFO](#)
74. INSTALL NO. 1 SIDE DEFROSTER NOZZLE_ [INFO](#)
75. INSTALL INSTRUMENT PANEL FINISH PANEL END LH_ [INFO](#)
76. CONNECT FRONT DOOR OPENING TRIM WEATHERSTRIP LH_ [INFO](#)
77. INSTALL NO. 1 CENTER INSTRUMENT CLUSTER FINISH PANEL_ [INFO](#)
78. INSTALL NO. 1 INSTRUMENT PANEL REGISTER_ [INFO](#)
79. INSTALL LOWER INSTRUMENT PANEL FINISH PANEL ASSEMBLY_ [INFO](#)
80. INSTALL COWL SIDE TRIM SUB-ASSEMBLY LH_ [INFO](#)
81. INSTALL FRONT DOOR SCUFF PLATE LH_ [INFO](#)
82. INSTALL NAVIGATION RECEIVER WITH BRACKET (w/ Navigation System)_ [INFO](#)
83. INSTALL RADIO RECEIVER WITH BRACKET (w/o Navigation System)_ [INFO](#)
84. INSTALL UPPER INSTRUMENT PANEL FINISH PANEL SUB-ASSEMBLY_ [INFO](#)
85. INSTALL INSTRUMENT CLUSTER FINISH PANEL GARNISH_ [INFO](#)
86. INSTALL LOWER CENTER INSTRUMENT CLUSTER FINISH PANEL SUB-ASSEMBLY_ [INFO](#)
87. INSTALL INTEGRATION CONTROL AND PANEL ASSEMBLY_ [INFO](#)
88. CONNECT OUTLET HEATER WATER HOSE

(a) Using pliers, grip the claws of the clip and slide the clip to connect the

outlet heater water hose.

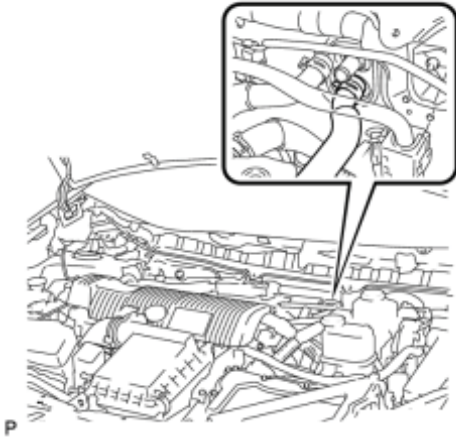

89. CONNECT INLET HEATER WATER HOSE

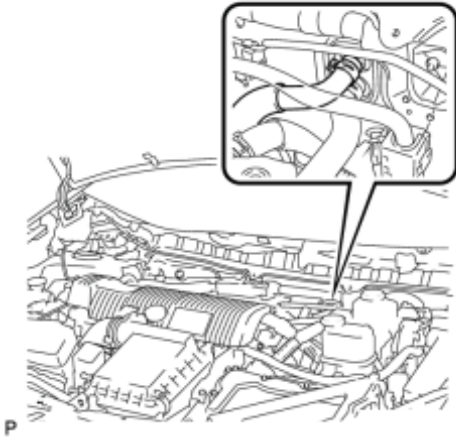

(a) Using pliers, grip the claws of the clip and slide the clip to connect the inlet heater water hose.

90. CONNECT AIR CONDITIONING TUBE AND ACCESSORY ASSEMBLY

(a) Remove the attached vinyl tape from the pipe.

(b) Sufficiently apply compressor oil to a new O-ring and the fitting surface of the air conditioning tube and accessory assembly.

Compressor oil:

ND-OIL 11 or equivalent

(c) Install the O-ring on the air conditioning tube and accessory assembly.

NOTICE:

- Keep the O-ring and O-ring fitting surfaces clean from dirt or any foreign objects.

- Do not use any compressor oil other than ND-OIL 11 or equivalent. If any compressor oil other than ND-OIL 11 or equivalent is used, compressor motor insulation performance may decrease, resulting in a leakage of electric power.

(d) Install the air conditioning tube and accessory assembly.

91. CONNECT SUCTION PIPE SUB-ASSEMBLY

(a) Remove the attached vinyl tape from the pipe.

(b) Sufficiently apply compressor oil to a new O-ring and the fitting surface of the suction pipe sub-assembly.

Compressor oil:

ND-OIL 11 or equivalent

(c) Install the O-ring on the suction pipe sub-assembly.

NOTICE:

- Keep the O-ring and O-ring fitting surfaces clean from dirt or any foreign objects.
- Do not use any compressor oil other than ND-OIL 11 or equivalent. If any compressor oil other than ND-OIL 11 or equivalent is used, compressor motor insulation performance may decrease, resulting in a leakage of electric power.

(d) Install the suction pipe sub-assembly.

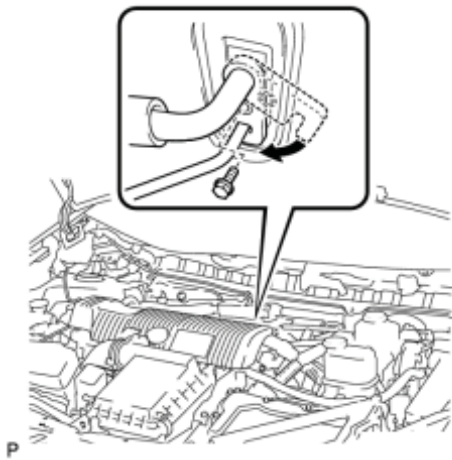

(e) Move the hook connector in the direction indicated by the arrow in the illustration.

(f) Insert the pipe joint into the fitting hole securely and tighten the bolt.

Torque: **9.8 N·m (100 kgf·cm, 87in·lbf)**

92. INSTALL OUTER COWL TOP PANEL SUB-ASSEMBLY_ INFO

93. INSTALL COWL BODY MOUNTING REINFORCEMENT LH_ INFO

94. INSTALL WINDSHIELD WIPER MOTOR AND LINK ASSEMBLY_ INFO

95. INSTALL COWL TOP VENTILATOR LOUVER SUB-ASSEMBLY_ INFO

96. INSTALL COWL SIDE VENTILATOR SUB-ASSEMBLY LH_ INFO

97. INSTALL COWL SIDE VENTILATOR SUB-ASSEMBLY RH_ INFO

98. INSTALL FRONT WIPER ARM AND BLADE ASSEMBLY RH_ INFO

99. INSTALL FRONT WIPER ARM AND BLADE ASSEMBLY LH_ INFO

100. INSTALL FRONT WIPER ARM HEAD CAP_ INFO

101. CONNECT CABLE TO NEGATIVE BATTERY TERMINAL

NOTICE:

When disconnecting the cable, some systems need to be initialized after the cable is reconnected INFO.

102. INSTALL REAR NO. 3 FLOOR BOARD_ INFO

103. INSTALL REAR DECK FLOOR BOX_ INFO

104. INSTALL REAR NO. 2 FLOOR BOARD (for Separate Type)_ INFO

105. ADD COOLANT (for Engine)_ INFO

106. CHARGE WITH REFRIGERANT_ INFO

107. WARM UP COMPRESSOR_ INFO

108. INSPECT FOR REFRIGERANT LEAK_ INFO

109. INSPECT FOR COOLANT LEAK (for Engine)_ INFO

110. INSPECT SHIFT LEVER_ INFO

111. INSPECT STEERING PAD

(a) Inspect the steering pad INFO.

112. INSPECT SRS WARNING LIGHT

(a) Inspect the SRS warning light INFO.

COMPONENTS

ILLUSTRATION

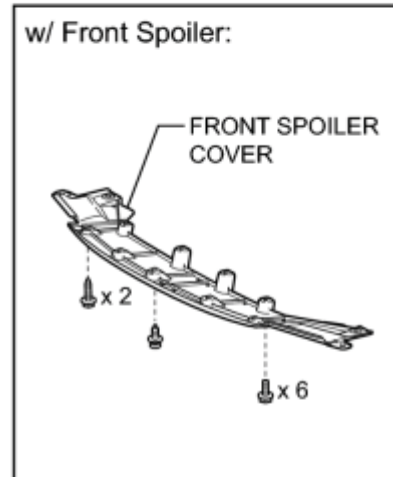
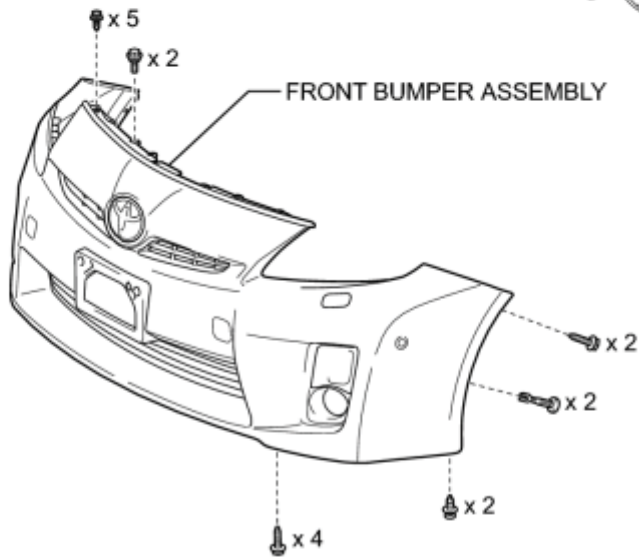
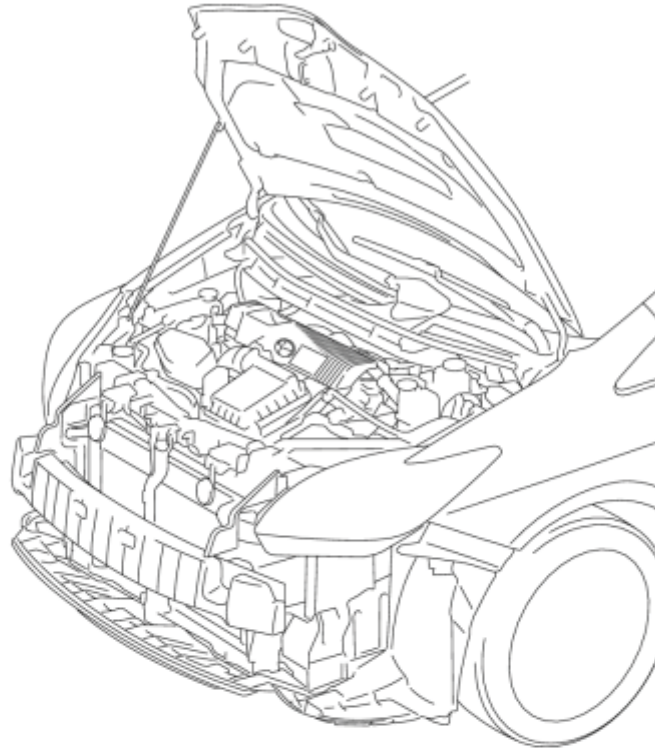
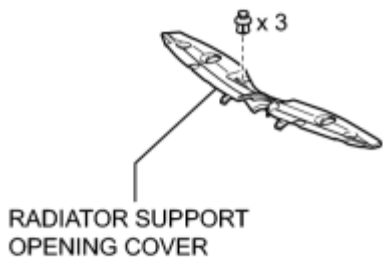

P

ILLUSTRATION

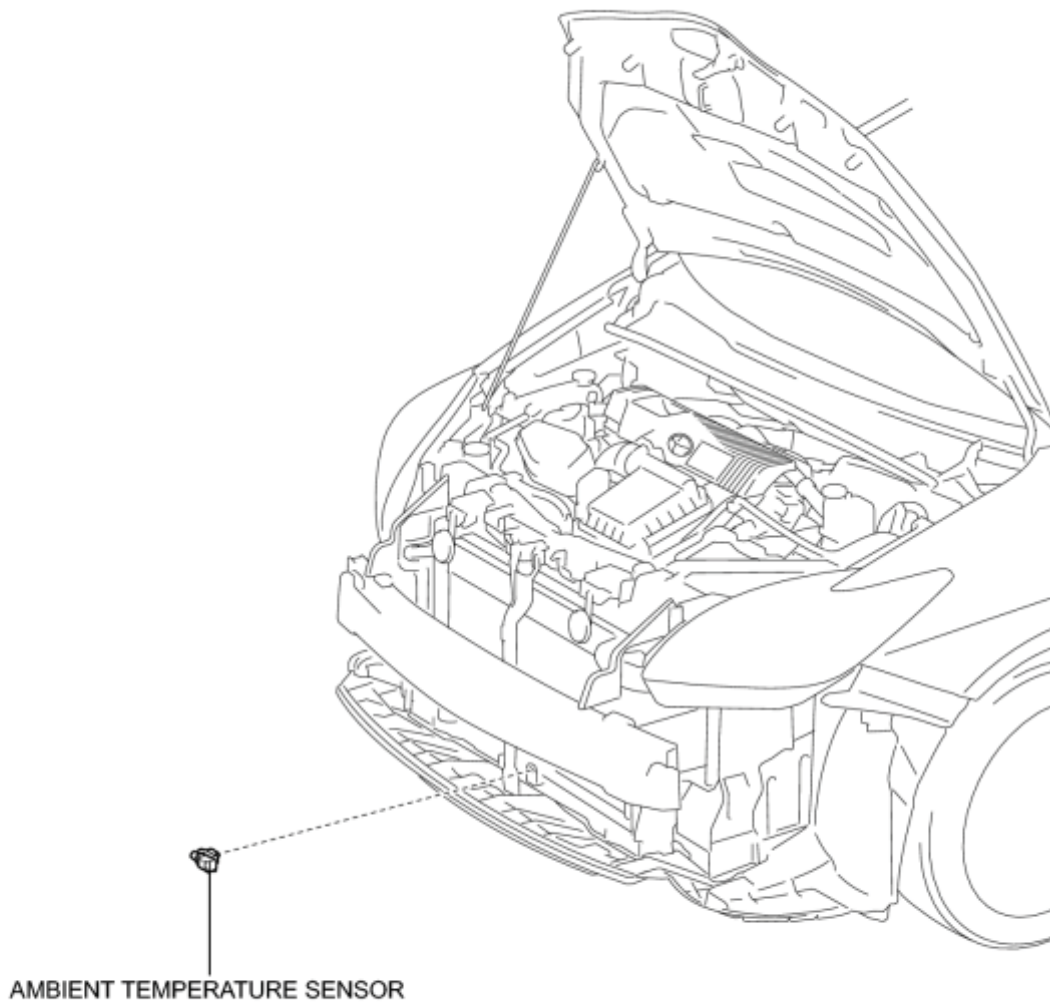

P

REMOVAL

1. REMOVE RADIATOR SUPPORT OPENING COVER_ [INFO](#)
2. REMOVE FRONT BUMPER ASSEMBLY_ [INFO](#)
3. REMOVE AMBIENT TEMPERATURE SENSOR

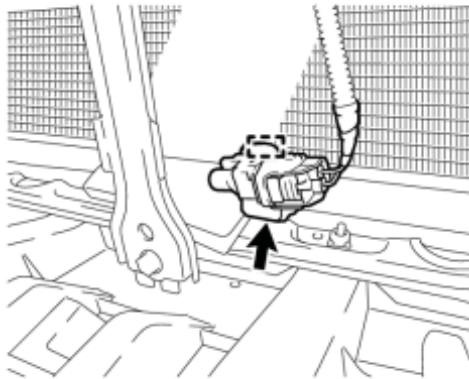

(a) Disconnect the connector.

P

(b) Disengage the clamp to remove the ambient temperature sensor.

INSPECTION

1. INSPECT AMBIENT TEMPERATURE SENSOR

(a) Measure the resistance according to the value(s) in the table below.

Standard Resistance:

Tester Connection	Condition	Specified Condition
1 - 2	10°C (50°F)	3.00 to 3.73 kΩ
1 - 2	15°C (59°F)	2.45 to 2.88 kΩ
1 - 2	20°C (68°F)	1.95 to 2.30 kΩ
1 - 2	25°C (77°F)	1.60 to 1.80 kΩ
1 - 2	30°C (86°F)	1.28 to 1.47 kΩ
1 - 2	35°C (95°F)	1.00 to 1.22 kΩ
1 - 2	40°C (104°F)	0.80 to 1.00 kΩ
1 - 2	45°C (113°F)	0.65 to 0.85 kΩ
1 - 2	50°C (122°F)	0.50 to 0.70 kΩ
1 - 2	55°C (131°F)	0.44 to 0.60 kΩ
1 - 2	60°C (140°F)	0.36 to 0.50 kΩ

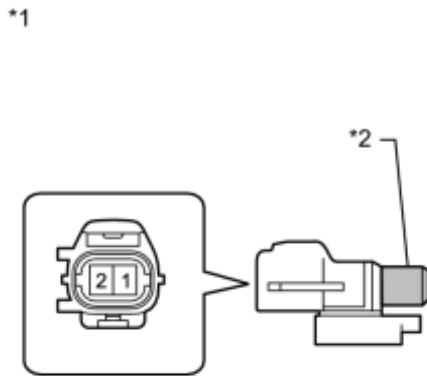

Resistance (kΩ)

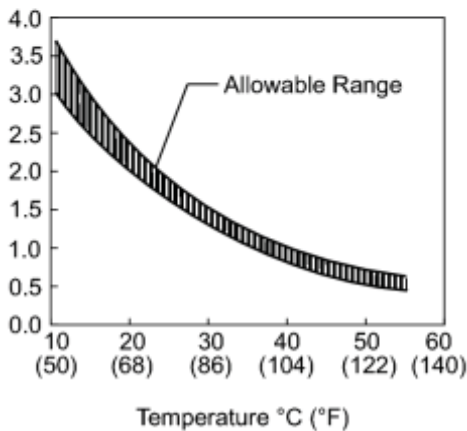

Text in Illustration

*1	Component without harness connected (Ambient Temperature Sensor)
*2	Sensing Portion

- Hold the sensor only by its connector. Touching the sensor may change the resistance value.
- When measuring, the sensor temperature must be the same as the ambient temperature.

HINT:

As the temperature increases, the resistance decreases (see the graph).

If the resistance is not as specified, replace the ambient temperature sensor.

INSTALLATION

1. INSTALL AMBIENT TEMPERATURE SENSOR

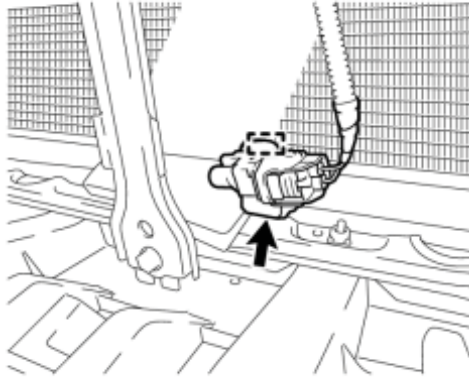

(a) Engage the clamp to install the ambient temperature sensor.

P

(b) Connect the connector.

2. INSTALL FRONT BUMPER ASSEMBLY [INFO](#)

3. INSTALL RADIATOR SUPPORT OPENING COVER [INFO](#)

4. ADD WINDSHIELD WASHER FLUID (w/ Headlight Cleaner System) [INFO](#)

5. ADJUST FOG LIGHT AIMING

HINT:

Refer to the procedure for Adjust Fog Light Aiming [INFO](#).

COMPONENTS

ILLUSTRATION

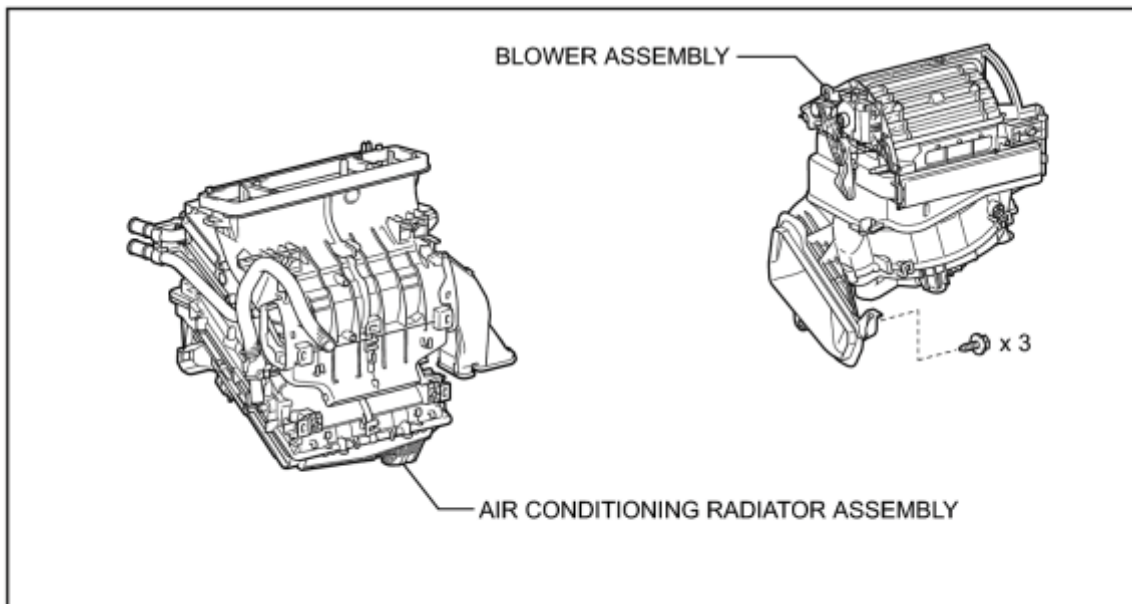
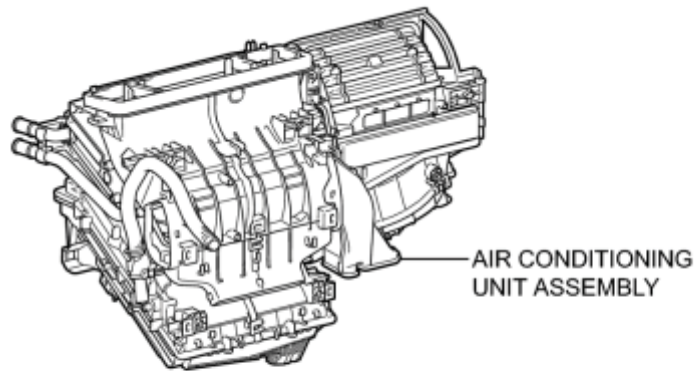

P

ILLUSTRATION

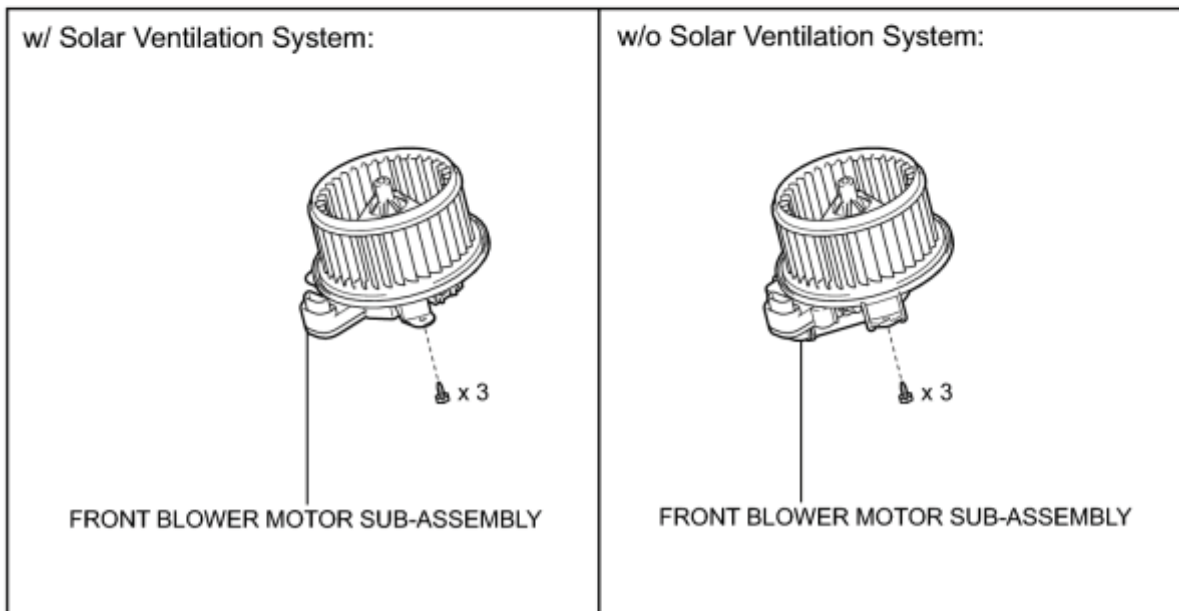
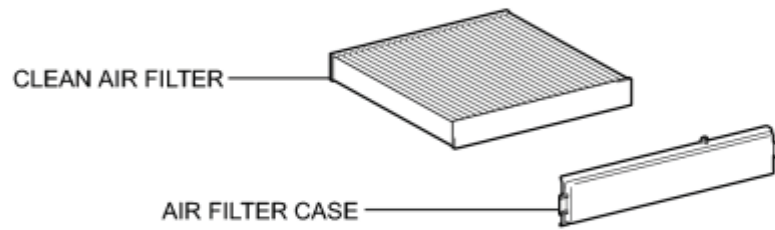
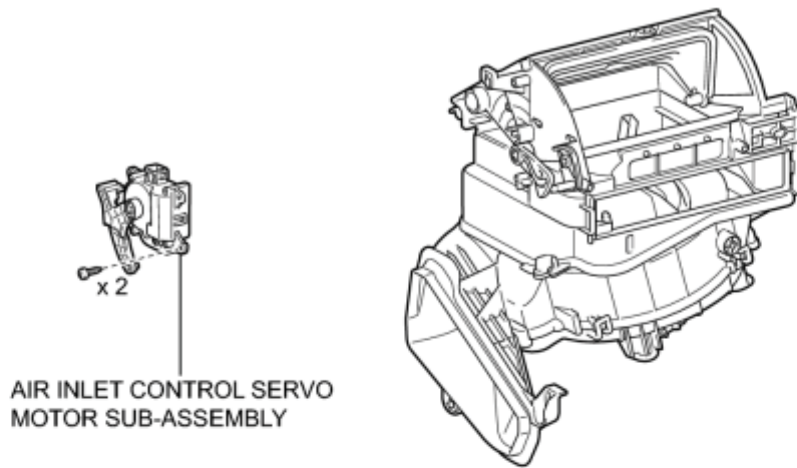

P

REMOVAL

1. REMOVE AIR CONDITIONING UNIT ASSEMBLY

HINT:

Refer to the procedure for Remove Air Conditioning Unit Assembly INFO.

2. REMOVE BLOWER ASSEMBLY

- (a) Remove the screw and disconnect the quick heater connector.
- (b) Disconnect the connector and disengage each clamp.
- (c) Disengage the 3 screws and guide, and remove the blower assembly.

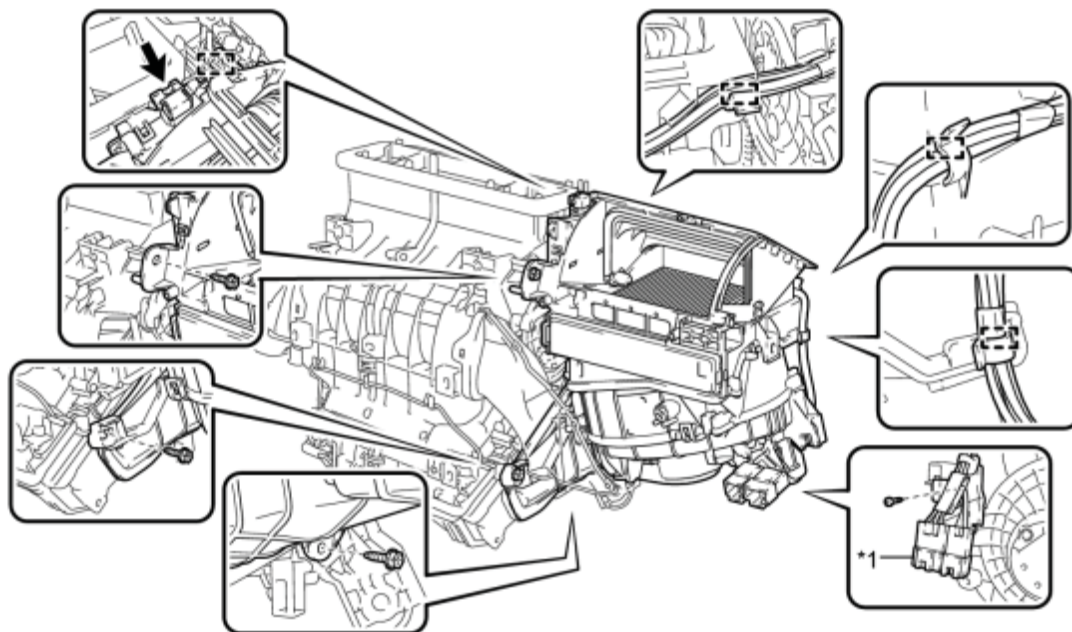

P

Text in Illustration

*1	Quick Heater Connector	-	-
----	------------------------	---	---

DISASSEMBLY

1. REMOVE AIR INLET CONTROL SERVO MOTOR SUB-ASSEMBLY

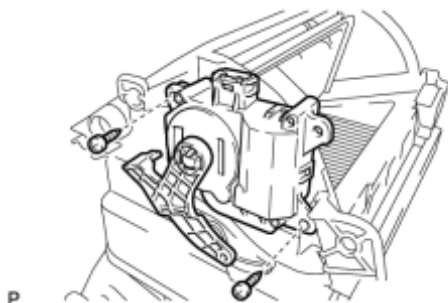

(a) Remove the 2 screws and air inlet control servo motor sub-assembly.

2. REMOVE AIR FILTER CASE

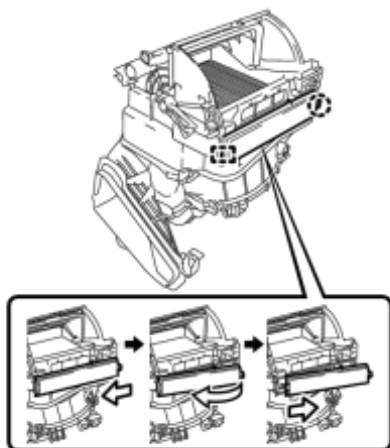

(a) Disengage the claw and guide, and remove the air filter case as shown in the illustration.

3. REMOVE CLEAN AIR FILTER

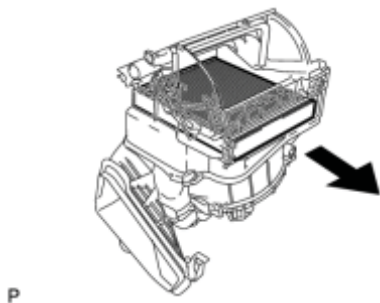

(a) Remove the clean air filter as shown in the illustration.

4. REMOVE FRONT BLOWER MOTOR SUB-ASSEMBLY (w/o Solar Ventilation System)

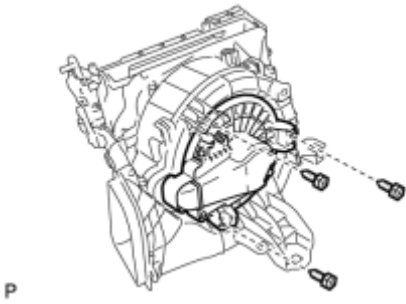

(a) Remove the 3 screws and front blower motor sub-assembly.

NOTICE:

Do not remove the front blower motor sub-assembly if it has been damaged or impacted.

5. REMOVE FRONT BLOWER MOTOR SUB-ASSEMBLY (w/ Solar Ventilation System)

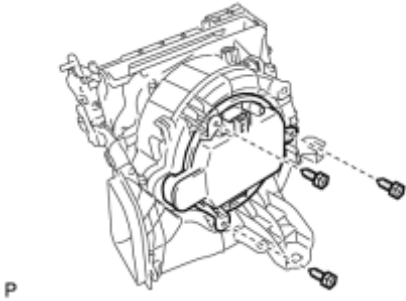

(a) Remove the 3 screws and front blower motor sub-assembly.

NOTICE:

Do not remove the front blower motor sub-assembly if it has been damaged or impacted.

REASSEMBLY

1. INSTALL FRONT BLOWER MOTOR SUB-ASSEMBLY (w/o Solar Ventilation System)

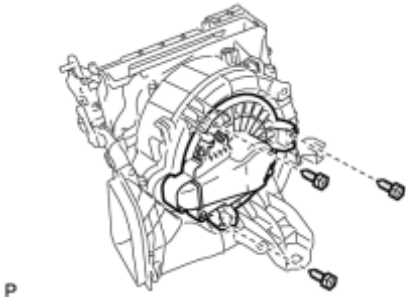

(a) Install the front blower motor sub-assembly with the 3 screws.

NOTICE:

Do not install the front blower motor sub-assembly if it has been damaged or impacted.

2. INSTALL FRONT BLOWER MOTOR SUB-ASSEMBLY (w/ Solar Ventilation System)

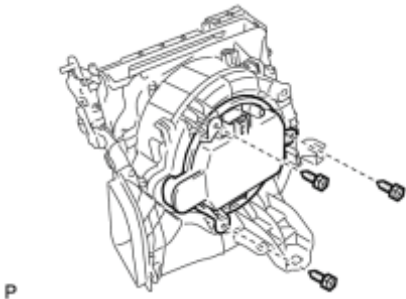

(a) Install the front blower motor sub-assembly with the 3 screws.

NOTICE:

Do not install the front blower motor sub-assembly if it has been damaged or impacted.

3. INSTALL CLEAN AIR FILTER

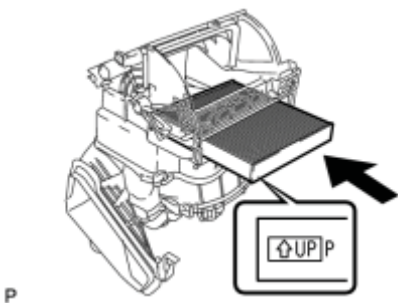

(a) Install the clean air filter as shown in the illustration.

4. INSTALL AIR FILTER CASE

(a) Engage the guide and claw to install the air filter case as shown in the illustration.

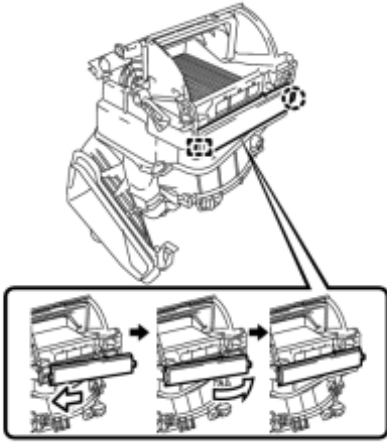

P

5. INSTALL AIR INLET CONTROL SERVO MOTOR SUB-ASSEMBLY

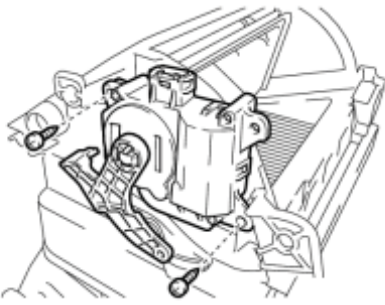

P

(a) Install the air inlet control servo motor sub-assembly with the 2 screws.

INSTALLATION

1. INSTALL BLOWER ASSEMBLY

- (a) Engage the guide.
- (b) Install the blower assembly with the 3 screws.
- (c) Connect the connector.
- (d) Engage each clamps.
- (e) Install the screw and connect the quick heater connector.

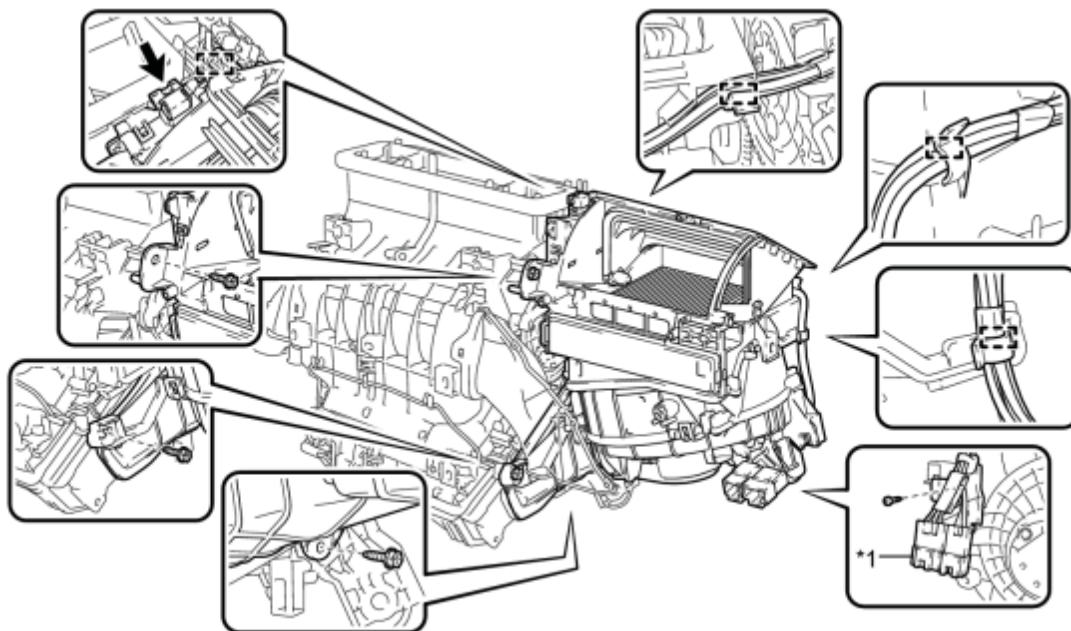

P

Text in Illustration

*1	Quick Heater Connector	-	-
----	------------------------	---	---

2. INSTALL AIR CONDITIONING UNIT ASSEMBLY

HINT:

Refer to the procedure for Install Air Conditioning Unit Assembly .

COMPONENTS

ILLUSTRATION

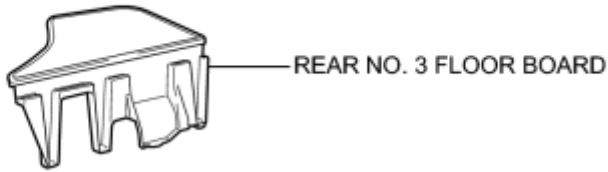

for Integrated Type:

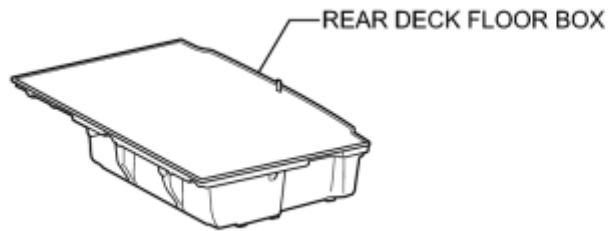

for Separate Type:

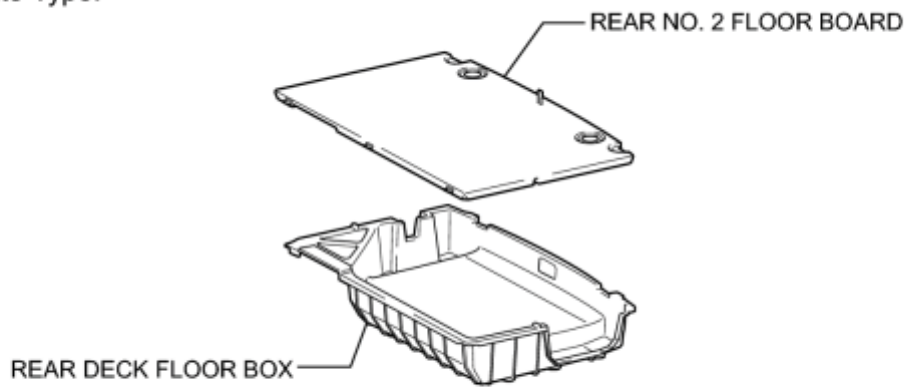

P

ILLUSTRATION

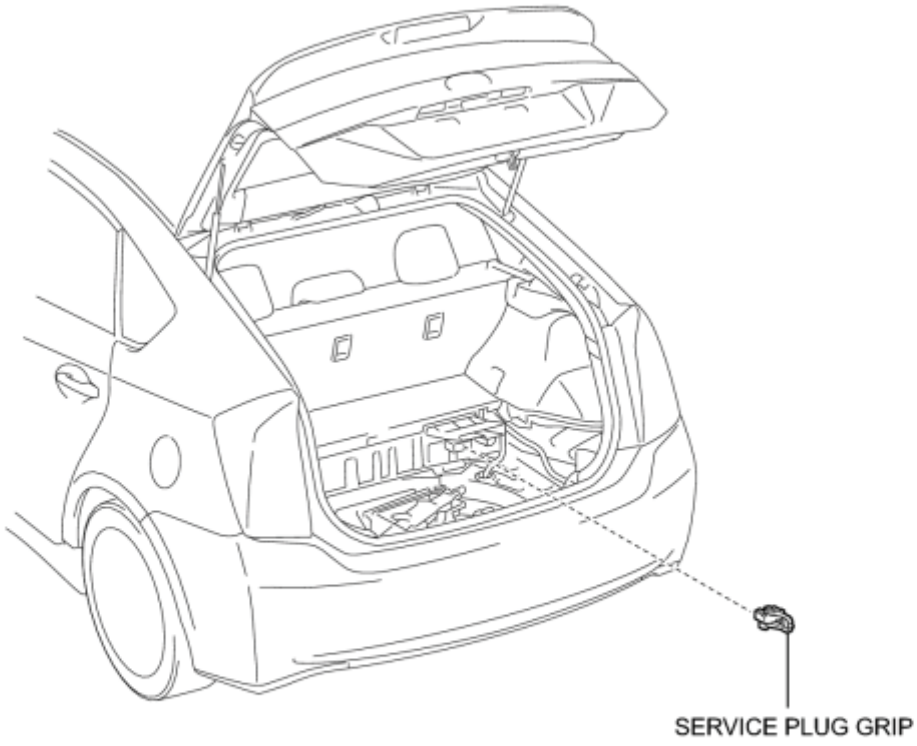

SERVICE PLUG GRIP

P

ILLUSTRATION

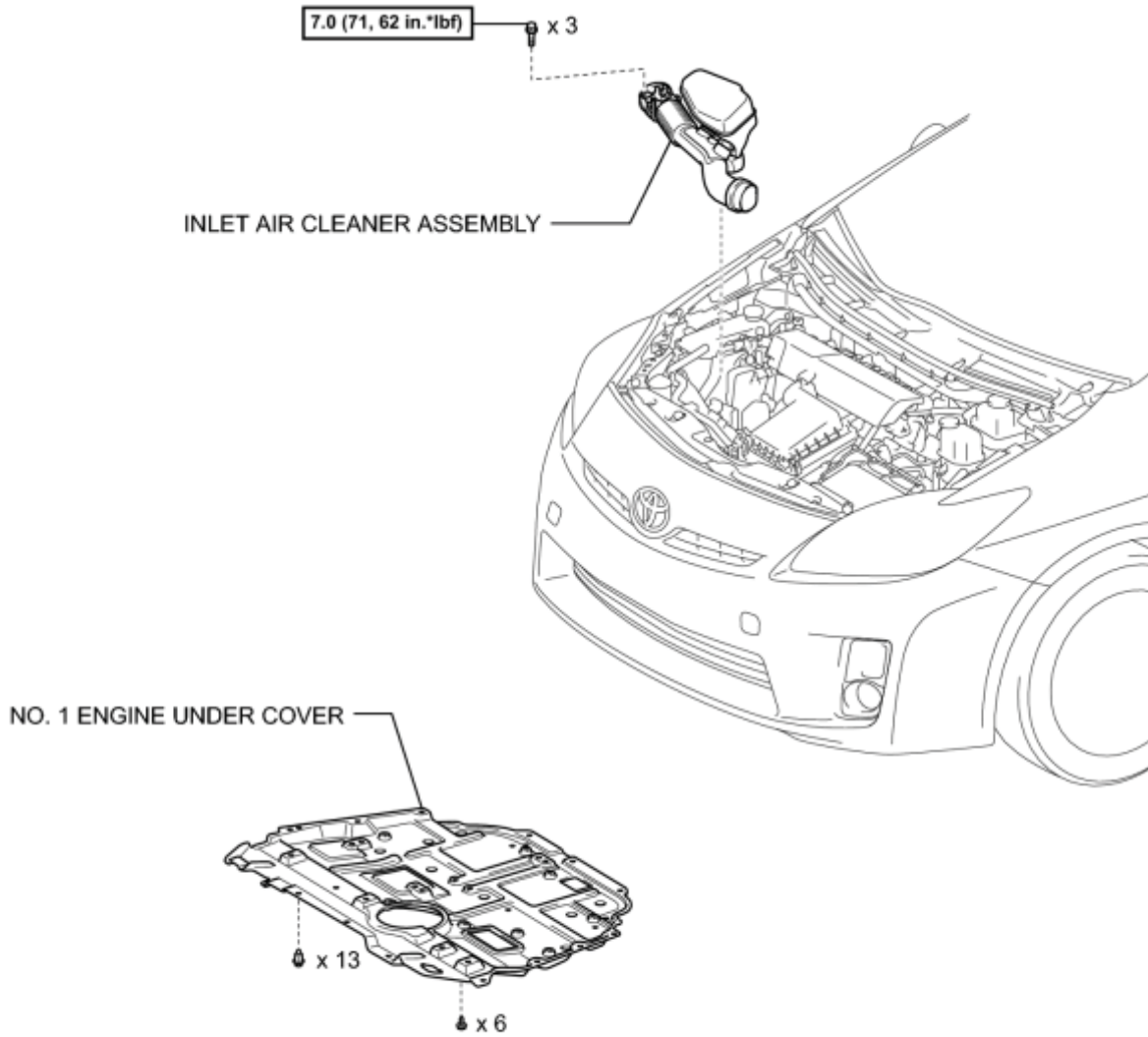

N*m (kgf*cm, ft.*lbf): Specified torque

P

ILLUSTRATION

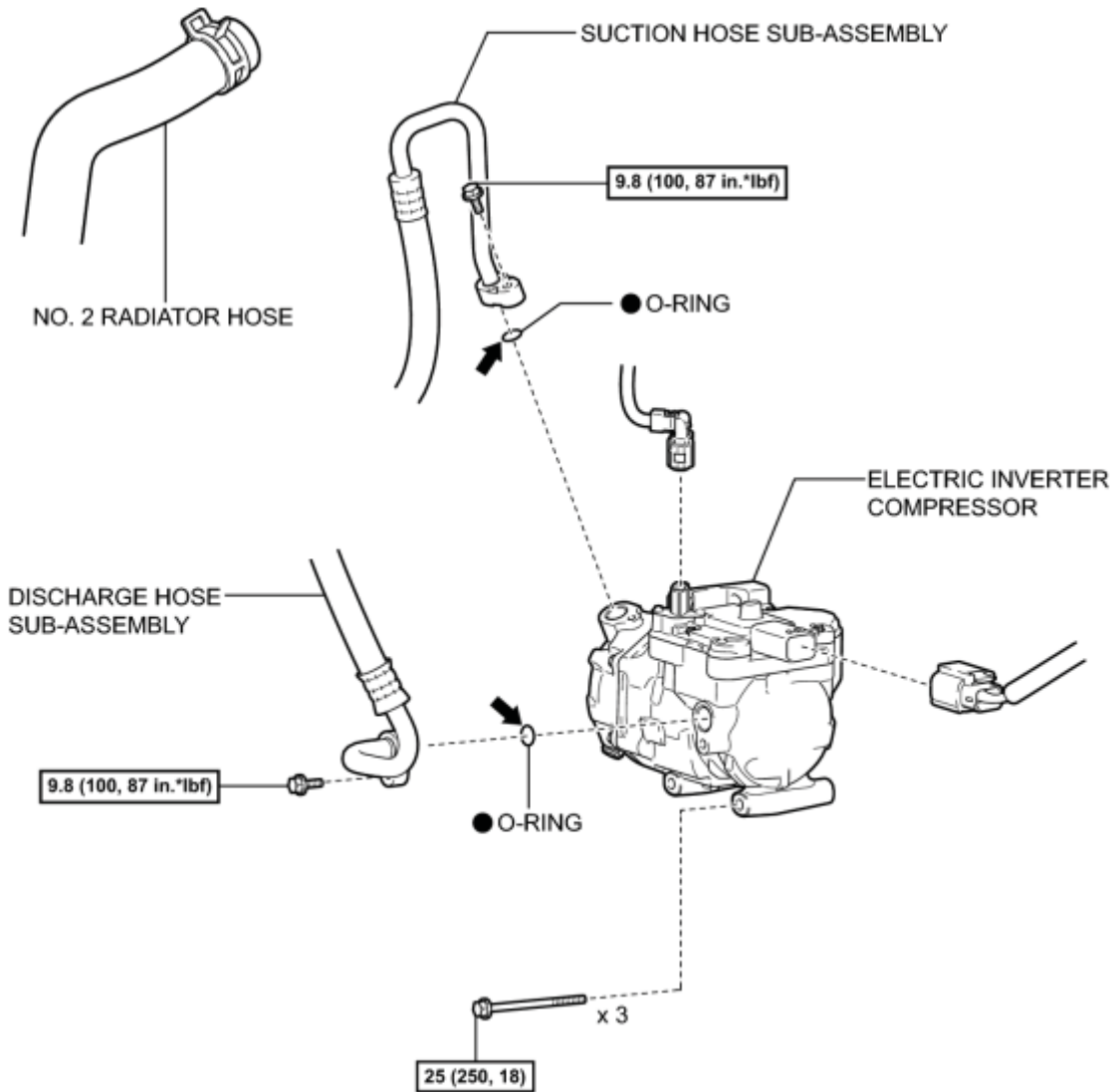

N*m (kgf*cm, ft.*lbf): Specified torque

● Non-reusable part

← Compressor oil ND-OIL 11 or equivalent

P

REMOVAL

1. PRECAUTION

INFO

2. RECOVER REFRIGERANT FROM REFRIGERATION SYSTEM_

INFO

3. REMOVE REAR NO. 2 FLOOR BOARD (for Separate Type)_

INFO

4. REMOVE REAR DECK FLOOR BOX_

INFO

5. REMOVE REAR NO. 3 FLOOR BOARD_

INFO

6. DISCONNECT CABLE FROM NEGATIVE BATTERY TERMINAL

NOTICE:

When disconnecting the cable, some systems need to be initialized after the cable is reconnected

INFO

7. REMOVE SERVICE PLUG GRIP_

INFO

8. CHECK TERMINAL VOLTAGE

(a) Remove the 9 bolts and inverter terminal cover.

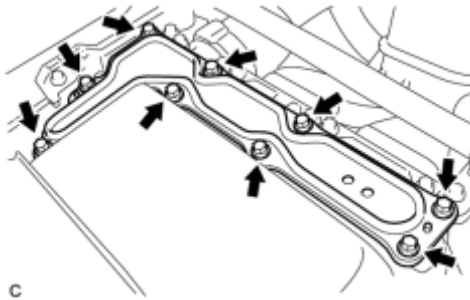

CAUTION:

Wear insulating gloves.

NOTICE:

Make sure to pull the inverter cover straight up, as a connector is connected to the bottom of the cover.

(b) Check the terminal voltage

INFO

CAUTION:

Wear insulating gloves.

(c) Install the inverter cover with the 9 bolts to the inverter with converter assembly.

Torque: **8.0 N·m (82 kgf·cm, 71in·lbf)**

CAUTION:

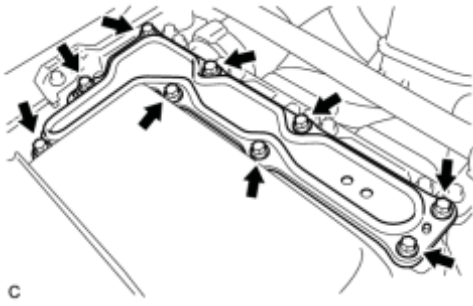

Wear insulating gloves.

- Make sure that the interlock is fully engaged.
- Do not allow any foreign objects or water drops to enter the inverter with converter assembly.

9. REMOVE INLET AIR CLEANER ASSEMBLY_ INFO

10. REMOVE NO. 1 ENGINE UNDER COVER

11. DRAIN COOLANT (for Engine)_ INFO

12. DISCONNECT NO. 2 RADIATOR HOSE

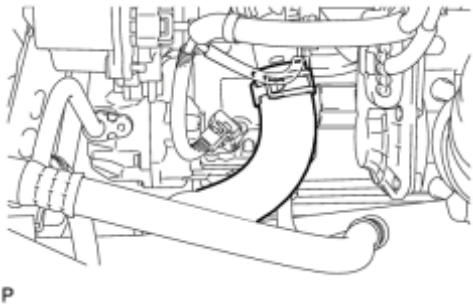

(a) Using pliers, grip the claws of the clip and slide the clip to remove the No. 2 radiator hose.

13. DISCONNECT DISCHARGE HOSE SUB-ASSEMBLY

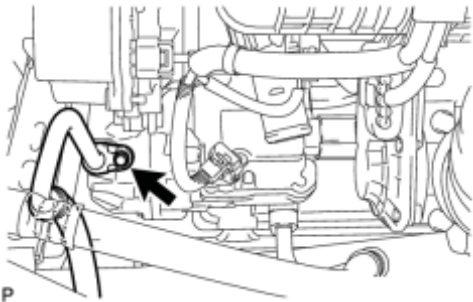

(a) Remove the bolt and disconnect the discharge hose sub-assembly from the electric inverter compressor.

(b) Remove the O-ring from the discharge hose sub-assembly.

NOTICE:

Seal the openings of the disconnected parts using vinyl tape to prevent entry of moisture and foreign matter.

14. DISCONNECT SUCTION HOSE SUB-ASSEMBLY

(a) Remove the bolt and disconnect the suction hose sub-assembly from the electric inverter compressor.

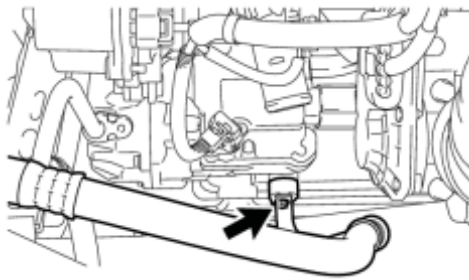

P

(b) Remove the O-ring from the suction hose sub-assembly.

NOTICE:

Seal the openings of the disconnected parts using vinyl tape to prevent entry of moisture and foreign matter.

15. REMOVE ELECTRIC INVERTER COMPRESSOR

(a) Release the green-colored lock and disconnect the connector <A> as shown in the illustration.

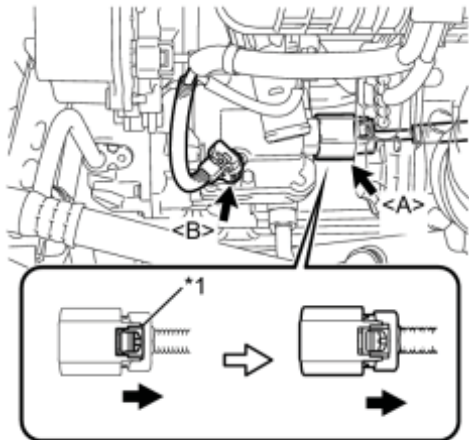

P

CAUTION:

Wear insulated gloves when performing the procedures.

NOTICE:

Insulate the connector by sealing it with tape.

Text in Illustration

*1	Green-colored Lock
----	--------------------

(b) Disconnect the connector .

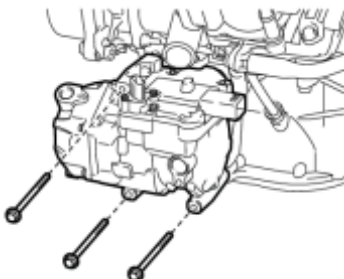

P

(c) Remove the 3 bolts and electric inverter compressor.

INSPECTION

1. INSPECT COMPRESSOR WITH MOTOR ASSEMBLY

CAUTION:

- Because the compressor has a high-voltage circuit, wear insulated gloves and pull out the service plug grip to cut off the high-voltage circuit before inspection.
- Do not touch the high-voltage connectors or terminals for 10 minutes after the service plug grip is removed.

NOTICE:

Do not start the engine with the service plug grip removed because it may cause a malfunction.

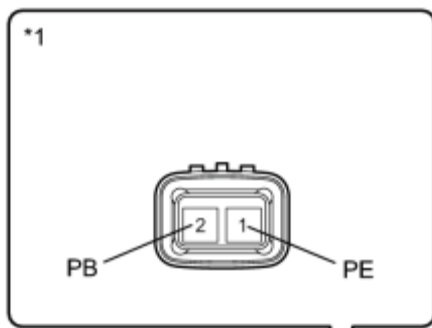

(a) Disconnect the compressor with motor assembly connector.

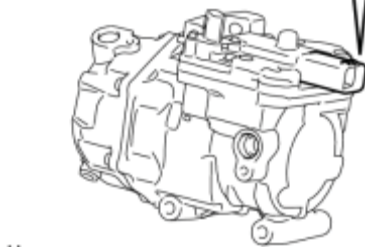

H

(b) Using a megohmmeter, measure the resistance according to the value(s) in the table below.

Standard Resistance:

Tester Connection	Condition	Specified Condition
E1-1 (PE) - Body ground	Always	2 MΩ or higher
E1-2 (PB) - Body ground	Always	2 MΩ or higher

Text in Illustration

*1	Component without harness connected (Compressor with motor assembly)
----	---

If the resistance is not as specified, replace the compressor with motor assembly.

INSTALLATION

1. ADJUST COMPRESSOR OIL

(a) When replacing the electric inverter compressor with a new one, gradually discharge the refrigerant gas from the service valve, and drain the following amount of oil from the new electric inverter compressor before installation.

Standard:

(Oil capacity inside the new electric inverter compressor: 130 to 145 cc (4.4 to 4.9 fl. oz.)) - (Remaining oil amount in the removed electric inverter compressor) = (Oil amount to be removed from the new compressor when replacing)

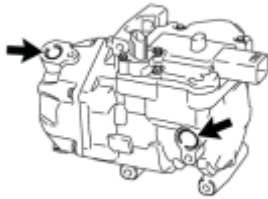

P

- When checking the compressor oil level, observe the precautions on the cooler removal/installation.
- If a new compressor and magnetic clutch are installed without removing some oil, there will be too much oil in the system due to the oil remaining in the pipes of the vehicle. Excessive oil in the system prevents heat exchange in the refrigeration cycle and causes refrigeration failure.
- If the amount of oil remaining in the old compressor and magnetic clutch is too small, check the A/C system for oil leaks.
- Be sure to use ND-OIL 11 or equivalent for compressor oil. If any compressor oil other than ND-OIL 11 is used, compressor motor insulation performance may decrease, resulting in a leakage of electric power.

2. INSTALL ELECTRIC INVERTER COMPRESSOR

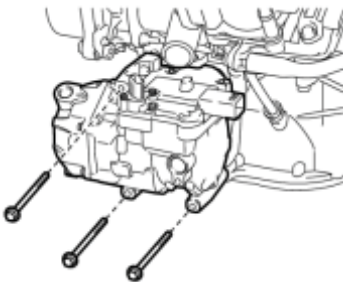

P

(a) Temporarily install the electric inverter compressor with the 3 bolts.

(b) Install the electric inverter compressor with the 3 bolts.

Torque: **25 N·m (250 kgf·cm, 18ft·lbf)**

NOTICE:

Tighten the bolts in the order shown in the illustration to install the

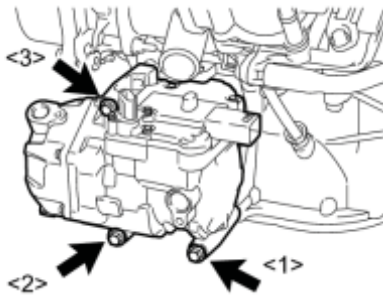

electric inverter compressor.

P

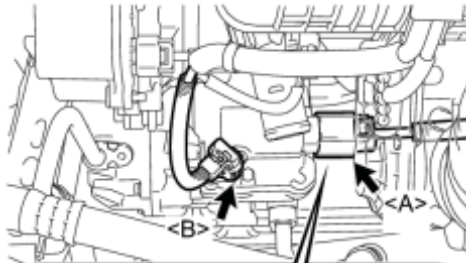

(c) Connect the connector <A> and lock the green-colored lock as shown in the illustration.

CAUTION:

Wear insulated gloves when performing the procedures.

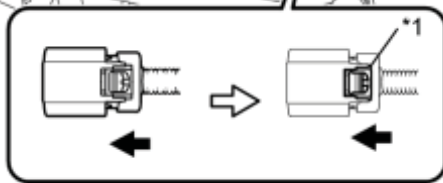

Text in Illustration

*1	Green-colored Lock
----	--------------------

P

(d) Connect the connector .

3. CONNECT SUCTION HOSE SUB-ASSEMBLY

(a) Remove the attached vinyl tape from the hose.

(b) Sufficiently apply compressor oil to a new O-ring and the fitting surface of the compressor and magnetic clutch.

Compressor oil:

ND-OIL 11 or equivalent

(c) Install the O-ring onto the suction hose sub-assembly.

NOTICE:

- Keep the O-ring and O-ring fitting surfaces free from dirt or any foreign objects.
- Do not use any compressor oil other than ND-OIL 11 or equivalent. If any compressor oil other than ND-OIL 11 or equivalent is used, compressor motor insulation performance may decrease, resulting in a leakage of electric power.

(d) Install the suction hose sub-assembly onto the compressor and magnetic clutch with the bolt.

Torque: **9.8 N·m (100 kgf·cm, 87in·lbf)**

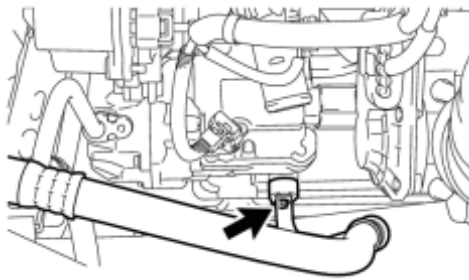

P

4. CONNECT DISCHARGE HOSE SUB-ASSEMBLY

(a) Remove the attached vinyl tape from the hose.

(b) Sufficiently apply compressor oil to a new O-ring and the fitting surface of the compressor and magnetic clutch.

Compressor oil:

ND-OIL 11 or equivalent

(c) Install the O-ring onto the discharge hose sub-assembly.

NOTICE:

- Keep the O-ring and O-ring fitting surfaces free from dirt or any foreign objects.
- Do not use any compressor oil other than ND-OIL 11 or equivalent. If any compressor oil other than ND-OIL 11 or equivalent is used, compressor motor insulation performance may decrease, resulting in a leakage of electric power.

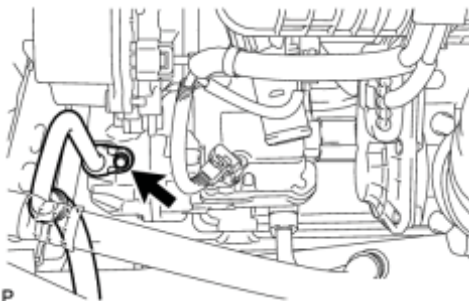

P

(d) Install the discharge hose sub-assembly onto the compressor and magnetic clutch with the bolt.

Torque: 9.8 N·m (100 kgf·cm, 87in·lbf)

5. CONNECT NO. 2 RADIATOR HOSE

(a) Using pliers, grip the claws of the clip and slide the clip to install the No. 2 radiator hose.

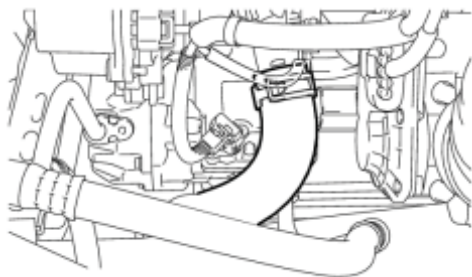

P

6. ADD COOLANT (for Engine)_ **INFO**

7. INSPECT FOR COOLANT LEAK (for Engine)_ **INFO**

8. INSTALL SERVICE PLUG GRIP_ **INFO**

9. CONNECT CABLE TO NEGATIVE BATTERY TERMINAL

NOTICE:

When disconnecting the cable, some systems need to be initialized after the cable is reconnected **INFO**.

10. INSTALL REAR NO. 3 FLOOR BOARD_ **INFO**

11. INSTALL REAR DECK FLOOR BOX_ **INFO**

12. INSTALL REAR NO. 2 FLOOR BOARD (for Separate Type)_ **INFO**

13. CHARGE WITH REFRIGERANT_ **INFO**

14. WARM UP COMPRESSOR_ **INFO**

15. INSPECT FOR REFRIGERANT LEAK_ **INFO**

16. INSTALL NO. 1 ENGINE UNDER COVER

17. INSTALL INLET AIR CLEANER ASSEMBLY_ **INFO**

COMPONENTS

ILLUSTRATION

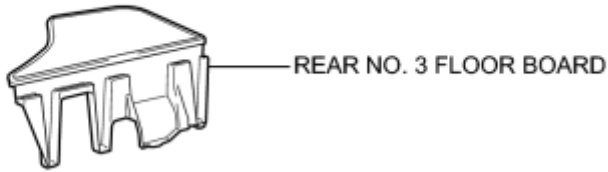

for Integrated Type:

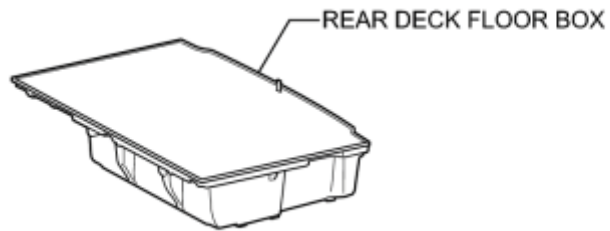

for Separate Type:

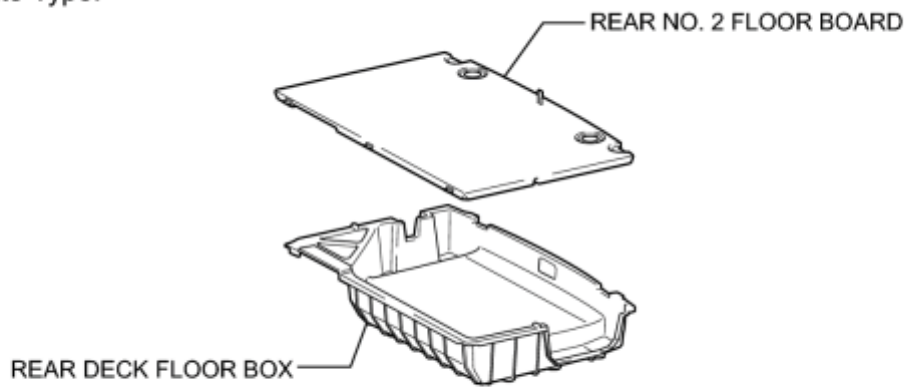

P

ILLUSTRATION

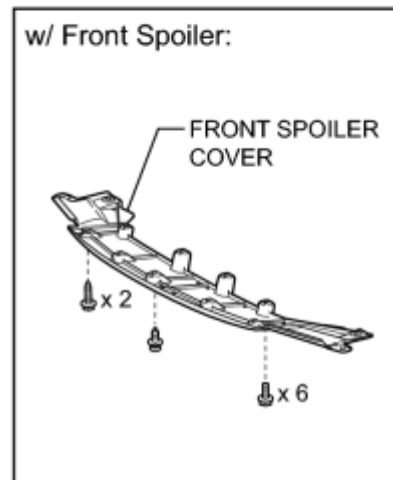
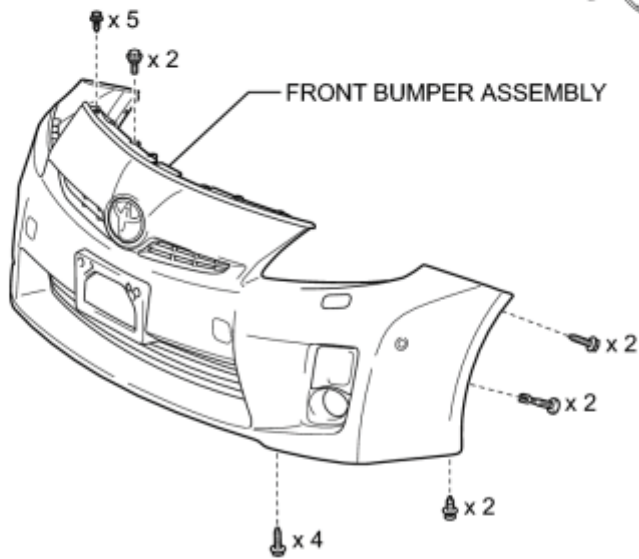
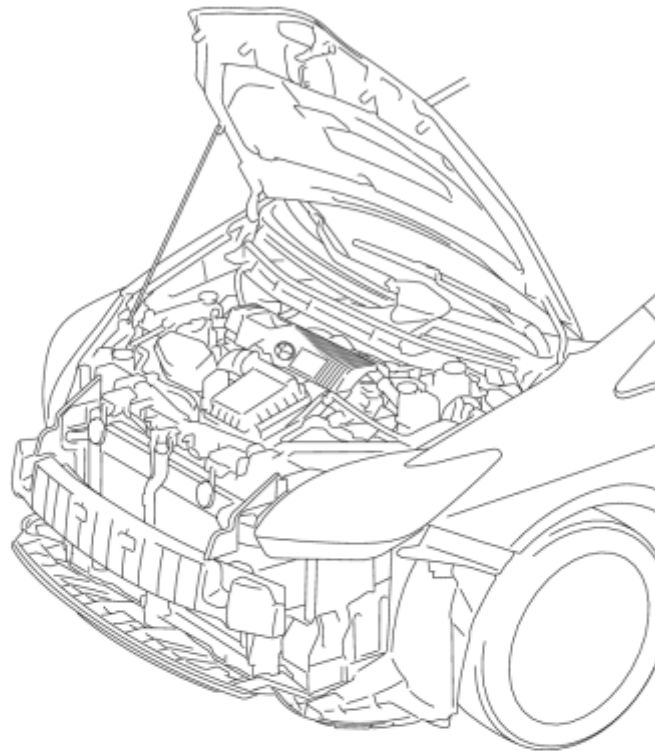
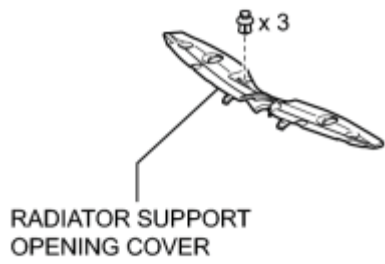

P

ILLUSTRATION

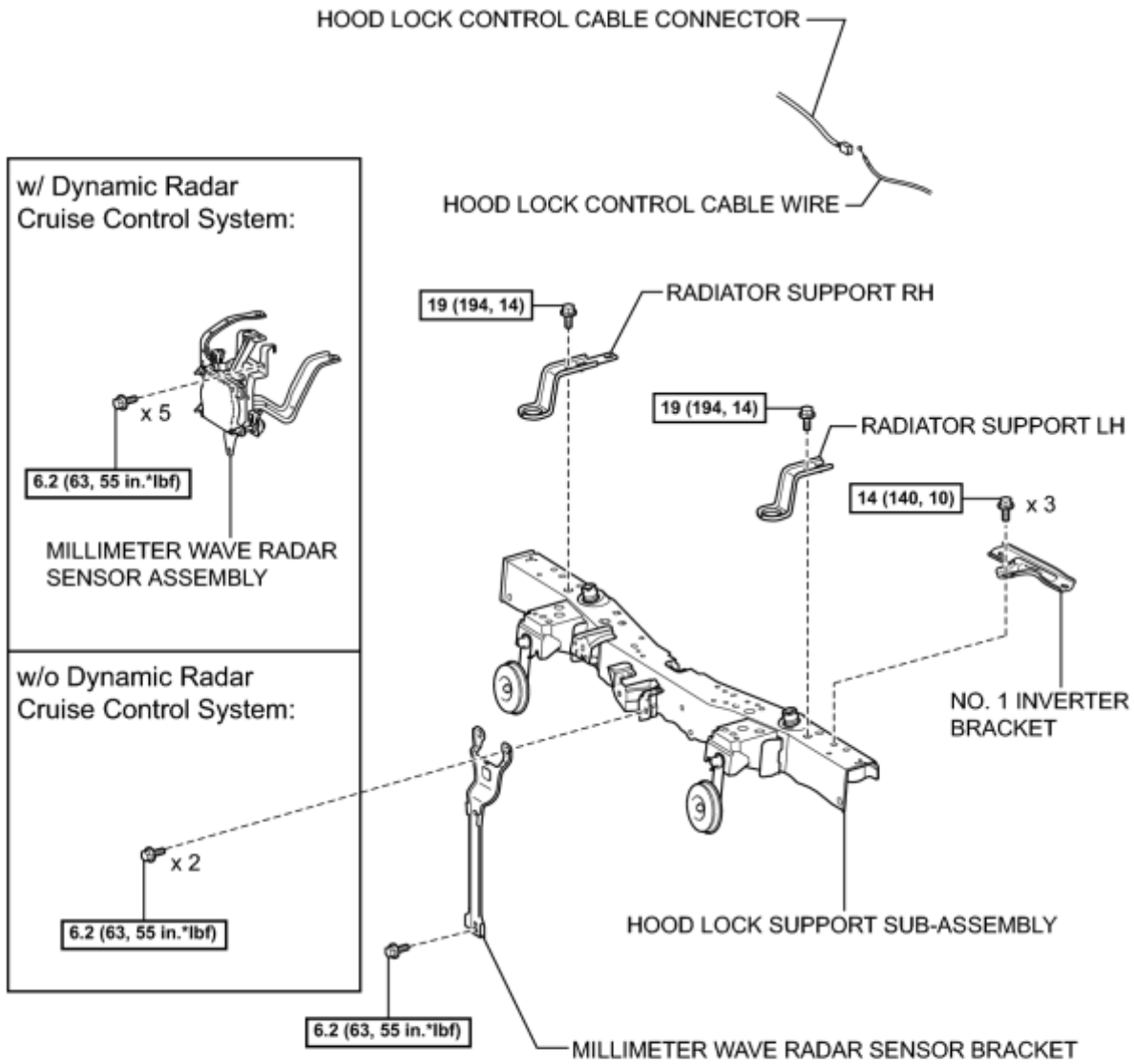

[N*m (kgf*cm, ft.*lbf)]: Specified torque

P

ILLUSTRATION

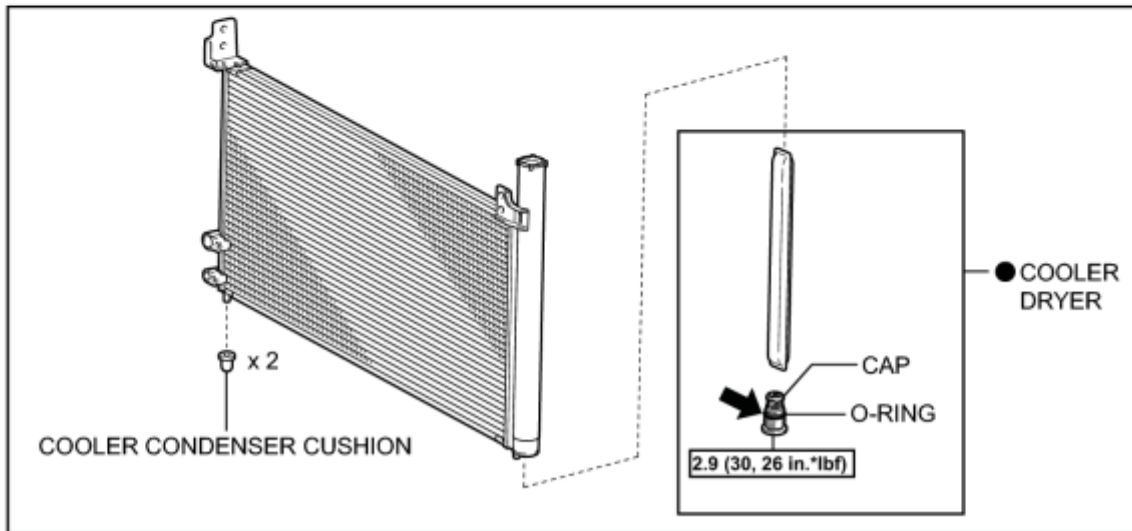
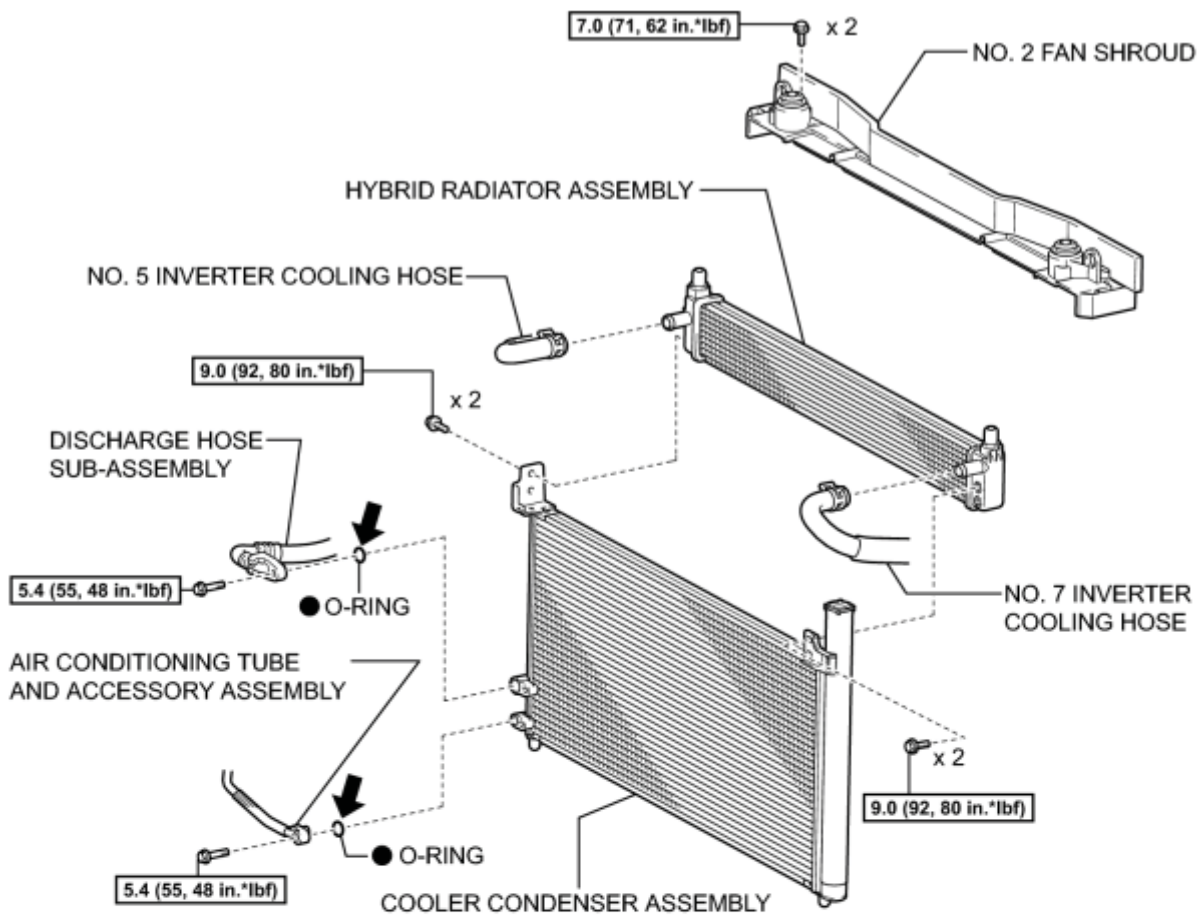

[N*m (kgf*cm, ft.*lbf)]: Specified torque

● Non-reusable part

← Compressor oil ND-OIL 11 or equivalent

P

ON-VEHICLE INSPECTION

1. INSPECT COOLER CONDENSER ASSEMBLY

(a) If the cooler condenser assembly fins are dirty, clean them with water and dry with compressed air.

NOTICE:

Do not damage the cooler condenser assembly fins.

(b) If any cooler condenser assembly fins are bent, straighten them using a screwdriver or pliers.

2. INSPECT FOR REFRIGERANT LEAK

(a) Using a halogen leak detector, check pipe joints for refrigerant leaks.

(b) If refrigerant leak is detected in a joint, check the torque of the joint.



REMOVAL

1. RECOVER REFRIGERANT FROM REFRIGERATION SYSTEM_ INFO

2. REMOVE REAR NO. 2 FLOOR BOARD (for Separate Type)_ INFO

3. REMOVE REAR DECK FLOOR BOX_ INFO

4. REMOVE REAR NO. 3 FLOOR BOARD_ INFO

5. DISCONNECT CABLE FROM NEGATIVE BATTERY TERMINAL

NOTICE:

When disconnecting the cable, some systems need to be initialized after the cable is reconnected INFO.

6. REMOVE RADIATOR SUPPORT OPENING COVER_ INFO

7. REMOVE FRONT BUMPER ASSEMBLY_ INFO

8. REMOVE MILLIMETER WAVE RADAR SENSOR ASSEMBLY (w/ Dynamic Radar Cruise Control System)_ INFO

9. REMOVE MILLIMETER WAVE RADAR SENSOR BRACKET

(a) w/o Dynamic Radar Cruise Control System:

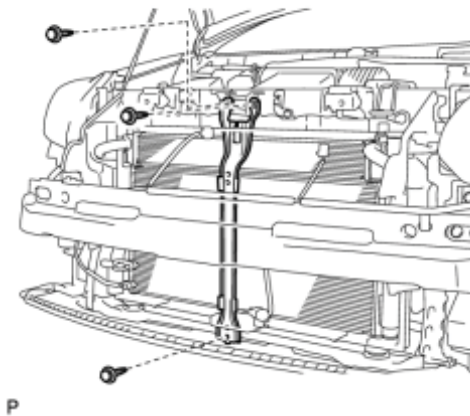

(1) Remove the 3 bolts and millimeter wave radar sensor bracket.

(b) w/ Dynamic Radar Cruise Control System:

(1) Remove the bolt and millimeter wave radar sensor bracket.

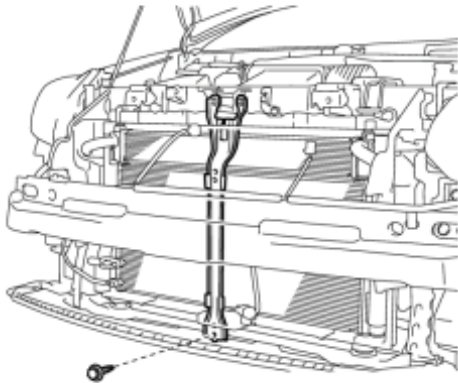

P

10. DISCONNECT DISCHARGE HOSE SUB-ASSEMBLY

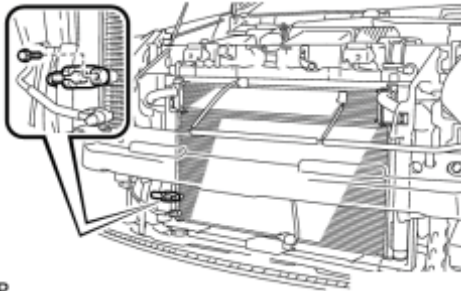

P

(a) Remove the bolt and disconnect the discharge hose sub-assembly.

(b) Remove the O-ring from the discharge hose sub-assembly.

NOTICE:

Seal the openings of the disconnected parts using vinyl tape to prevent entry of moisture and foreign matter.

11. DISCONNECT AIR CONDITIONING TUBE AND ACCESSORY ASSEMBLY

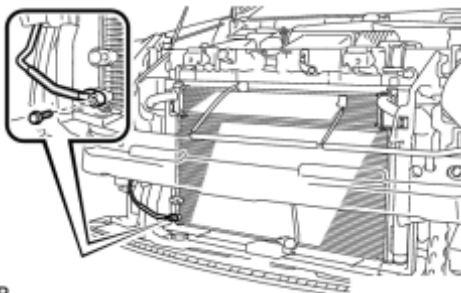

P

(a) Remove the bolt and disconnect the air conditioning tube and accessory assembly.

(b) Remove the O-ring from the air conditioning tube and accessory assembly.

NOTICE:

Seal the openings of the disconnected parts using vinyl tape to prevent entry of moisture and foreign matter.

12. DISCONNECT NO. 5 INVERTER COOLING HOSE

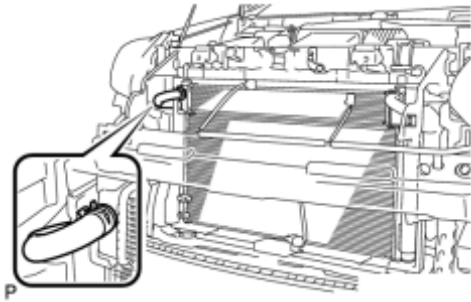

(a) Using pliers, grip the claws of the clip and slide the clip to disconnect the No. 5 inverter cooling hose.

- Do not apply excessive force to the No. 5 inverter cooling hose.
- Prepare a drain pan or cloth in case the coolant leaks.

13. DISCONNECT NO. 7 INVERTER COOLING HOSE

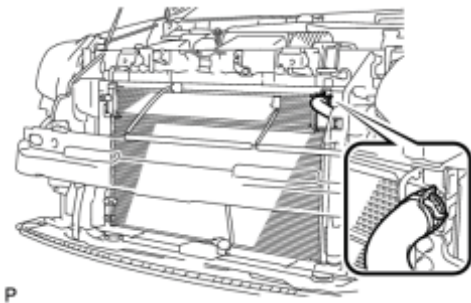

(a) Using pliers, grip the claws of the clip and slide the clip to disconnect the No. 7 inverter cooling hose.

- Do not apply excessive force to the No. 7 inverter cooling hose.
- Prepare a drain pan or cloth in case the coolant leaks.

14. REMOVE NO. 1 INVERTER BRACKET INFO

15. REMOVE HOOD LOCK SUPPORT SUB-ASSEMBLY INFO

16. REMOVE NO. 2 FAN SHROUD INFO

17. REMOVE COOLER CONDENSER ASSEMBLY

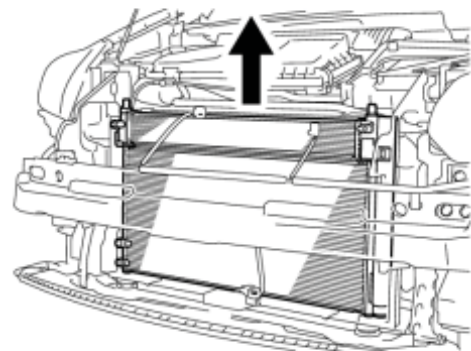

(a) Remove the cooler condenser assembly with hybrid radiator assembly.

(b) Remove the 4 bolts and cooler condenser assembly from the hybrid radiator assembly.

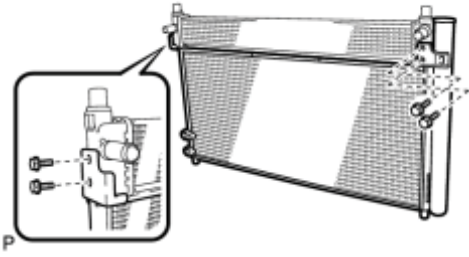

DISASSEMBLY

1. REMOVE COOLER CONDENSER CUSHION

(a) for LH Side:

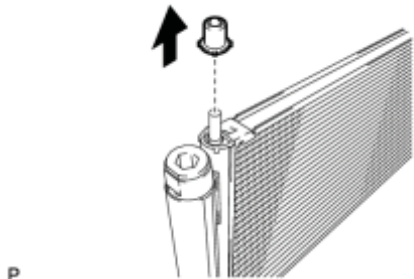

(1) Remove the cooler condenser cushion.

(b) for RH Side:

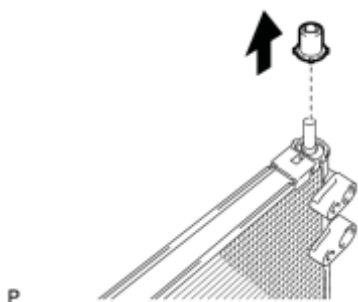

(1) Remove the cooler condenser cushion.

2. REMOVE COOLER DRYER

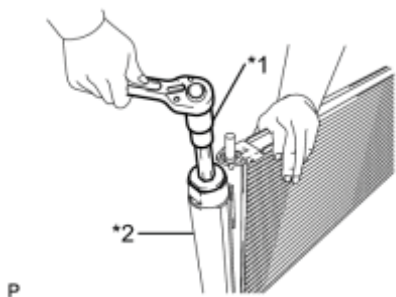

(a) Using a 14 mm straight hexagon wrench, remove the cap from the modulator.

Text in Illustration

*1	14 mm Straight Hexagon Wrench
*2	Modulator

(b) Using pliers, remove the cooler dryer.

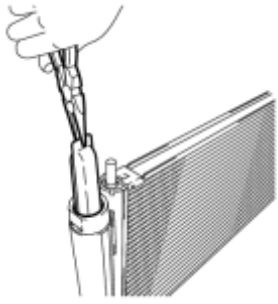

P

REASSEMBLY

1. INSTALL COOLER DRYER

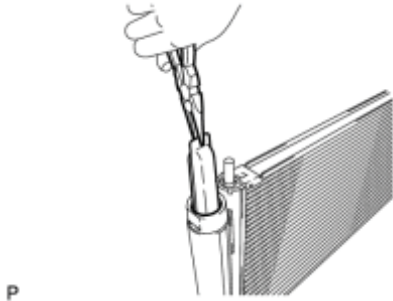

(a) Using pliers, install a new cooler dryer to the modulator.

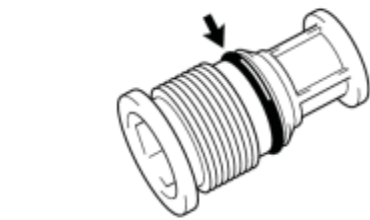

(b) Sufficiently apply compressor oil to a new O-ring and the fitting surfaces of the cap.

Compressor oil:

ND-OIL 11 or equivalent

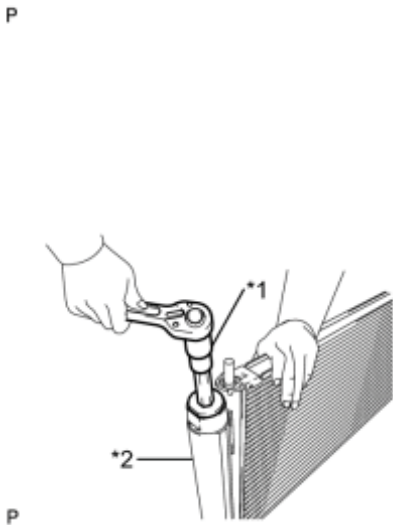

(c) Using a 14 mm straight hexagon wrench, install the cap to the cooler condenser core.

Torque: **2.9 N·m (30 kgf·cm, 26in·lbf)**

- Keep the O-ring and O-ring fitting surfaces clean from dirt or any foreign objects.
- Do not use any compressor oil other than ND-OIL 11 or equivalent. If any compressor oil other than ND-OIL 11 or equivalent is used, compressor motor insulation performance may decrease, resulting in a leakage of electric power.

Text in Illustration

*1	14 mm Straight Hexagon Wrench
*2	Modulator

2. INSTALL COOLER CONDENSER CUSHION

(a) for LH Side:

(1) Install the cooler condenser cushion.

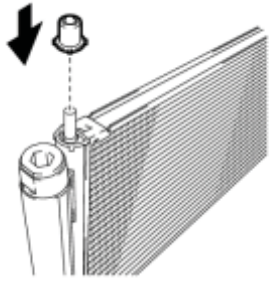

P

(b) for RH Side:

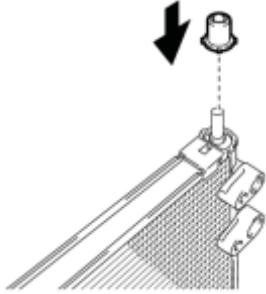

P

(1) Install the cooler condenser cushion.

INSTALLATION

1. INSTALL COOLER CONDENSER ASSEMBLY

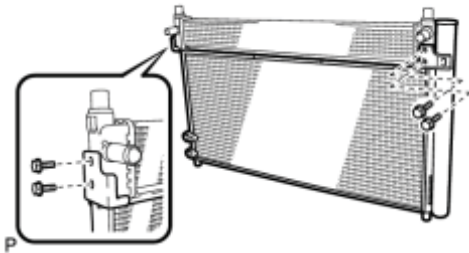

(a) Install the cooler condenser assembly with the 4 bolts to the hybrid radiator assembly.

Torque: **9.0 N·m (92 kgf·cm, 80in·lbf)**

(b) Install the cooler condenser assembly.

HINT:

If the condenser is replaced with a new one, add compressor oil to the new condenser.

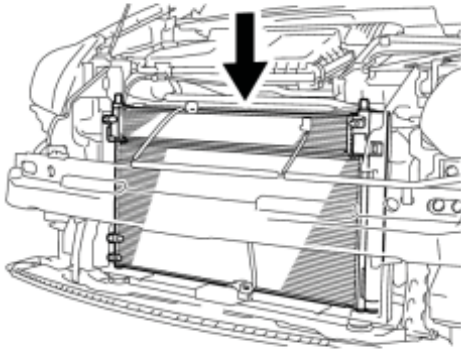

Capacity:

40 cc (1.35 fl. oz.)

Compressor oil:

ND-11 or equivalent

NOTICE:

Do not use any compressor oil other than ND-OIL 11 or equivalent. If any compressor oil other than ND-OIL 11 or equivalent is used, compressor motor insulation performance may decrease, resulting in a leakage of electric power.

2. INSTALL NO. 2 FAN SHROUD_ INFO

3. INSTALL HOOD LOCK SUPPORT SUB-ASSEMBLY_ INFO

4. INSTALL NO. 1 INVERTER BRACKET_ INFO

5. CONNECT NO. 7 INVERTER COOLING HOSE

(a) Using pliers, grip the claws of the clip and slide the clip to connect the No. 7 inverter cooling hose.

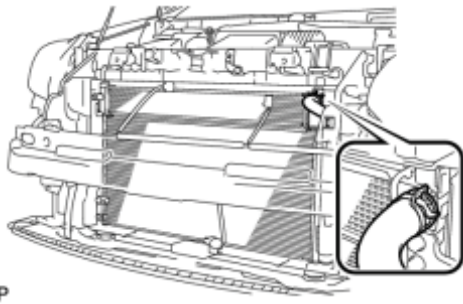

P

6. CONNECT NO. 5 INVERTER COOLING HOSE

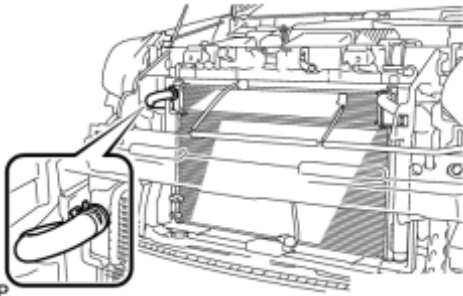

P

(a) Using pliers, grip the claws of the clip and slide the clip to connect the No. 5 inverter cooling hose.

7. CONNECT AIR CONDITIONING TUBE AND ACCESSORY ASSEMBLY

(a) Remove the attached vinyl tape from the pipe and the connecting part of the cooler condenser assembly.

(b) Sufficiently apply compressor oil to a new O-ring and the fitting surface of the pipe joint.

Compressor oil:

ND-OIL 11 or equivalent

(c) Install the O-ring on the air conditioning tube and accessory assembly.

NOTICE:

- Keep the O-ring and O-ring fitting surfaces clean from dirt or any foreign objects.
- Do not use any compressor oil other than ND-OIL 11 or equivalent. If any compressor oil other than ND-OIL 11 or equivalent is used, compressor motor insulation performance may decrease, resulting in a leakage of electric power.

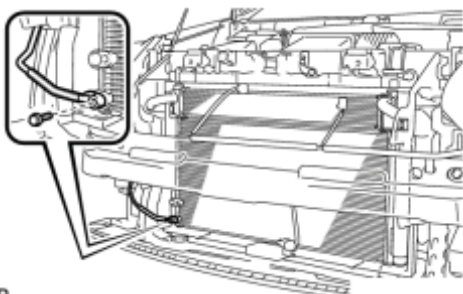

P

(d) Install the air conditioning tube and accessory assembly on the cooler condenser assembly with the bolt.

Torque: **5.4 N·m (55 kgf·cm, 48in·lbf)**

8. CONNECT DISCHARGE HOSE SUB-ASSEMBLY

- (a) Remove the attached vinyl tape from the hose and the connecting part of the cooler condenser assembly.
- (b) Sufficiently apply compressor oil to a new O-ring and the fitting surface of the hose joint.

Compressor oil:

ND-OIL 11 or equivalent

- (c) Install the O-ring on the discharge hose sub-assembly.

NOTICE:

- Keep the O-ring and O-ring fitting surfaces clean from dirt or any foreign objects.
- Do not use any compressor oil other than ND-OIL 11 or equivalent. If any compressor oil other than ND-OIL 11 or equivalent is used, compressor motor insulation performance may decrease, resulting in a leakage of electric power.

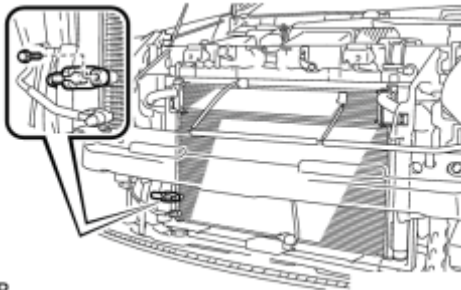

- (d) Install the discharge hose sub-assembly on the cooler condenser assembly with the bolt.

Torque: **5.4 N·m (55 kgf·cm, 48in·lbf)**

9. INSTALL MILLIMETER WAVE RADAR SENSOR BRACKET

- (a) w/o Dynamic Radar Cruise Control System:

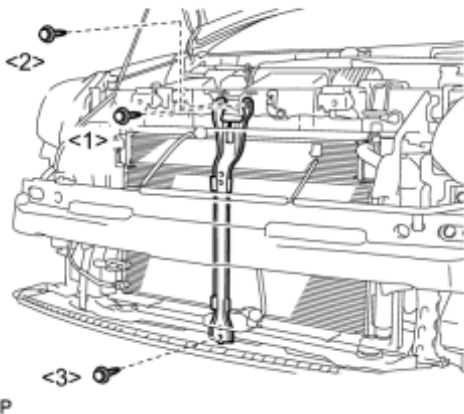

- (1) Install the millimeter wave radar sensor bracket with the 3 bolts.

Torque: **6.2 N·m (63 kgf·cm, 55in·lbf)**

NOTICE:

Tighten the bolts in the order shown in the illustration to install the millimeter wave radar sensor bracket.

- (b) w/ Dynamic Radar Cruise Control System:

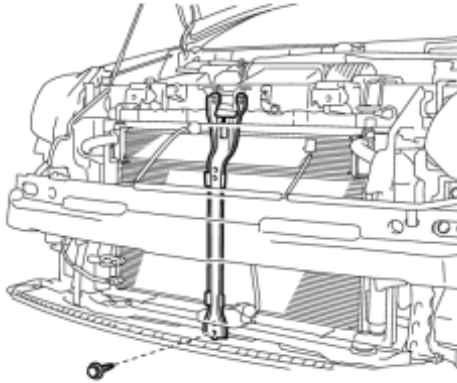

(1) Install the millimeter wave radar sensor bracket with the bolt.

Torque: **6.2 N·m (63 kgf·cm, 55in·lbf)**

P

10. INSTALL MILLIMETER WAVE RADAR SENSOR ASSEMBLY (w/ Dynamic Radar Cruise Control System) [INFO](#)

11. INSTALL FRONT BUMPER ASSEMBLY [INFO](#)

12. ADD WASHER FLUID (w/ Headlight Cleaner System) [INFO](#)

13. CONNECT CABLE TO NEGATIVE BATTERY TERMINAL

NOTICE:

When disconnecting the cable, some systems need to be initialized after the cable is reconnected [INFO](#).

14. INSTALL REAR NO. 3 FLOOR BOARD [INFO](#)

15. INSTALL REAR DECK FLOOR BOX [INFO](#)

16. INSTALL REAR NO. 2 FLOOR BOARD (for Separate Type) [INFO](#)

17. CHARGE WITH REFRIGERANT [INFO](#)

18. ADD COOLANT (for Inverter) [INFO](#)

19. WARM UP COMPRESSOR [INFO](#)

20. INSPECT FOR REFRIGERANT LEAK [INFO](#)

21. INSPECT FOR COOLANT LEAK (for Inverter) [INFO](#)

22. ADJUST FOG LIGHT AIMING

HINT:

Refer to the procedure for Adjust Fog Light Aiming [INFO](#).

23. ADJUST HOOD SUB-ASSEMBLY

HINT:

Refer to the procedure for Adjust Hood Sub-assembly [INFO](#).

24. ADJUST MILLIMETER WAVE RADAR SENSOR ASSEMBLY (w/ Dynamic Radar Cruise Control System) [INFO](#)

25. INSTALL RADIATOR SUPPORT OPENING COVER [INFO](#)

COMPONENTS

ILLUSTRATION

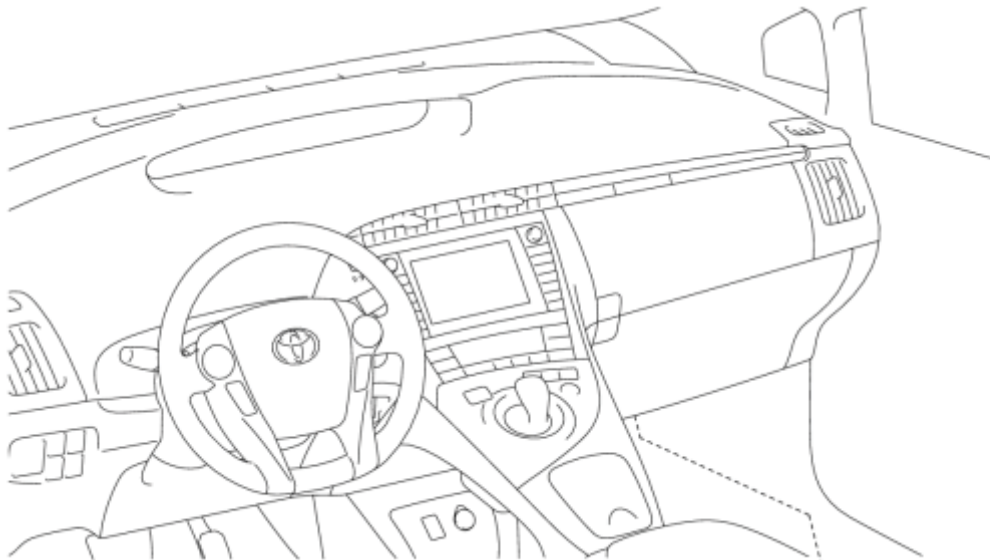

w/ Solar Ventilation System:



FRONT BLOWER MOTOR SUB-ASSEMBLY x 3

w/o Solar Ventilation System:

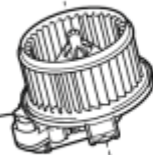

FRONT BLOWER MOTOR SUB-ASSEMBLY x 3



NO. 2 INSTRUMENT PANEL UNDER COVER SUB-ASSEMBLY

P

REMOVAL

1. PRECAUTION (w/ Solar Ventilation System)

NOTICE:

Make sure to turn off the solar ventilation switch to prevent the blower motor from operating unexpectedly.

2. REMOVE NO. 2 INSTRUMENT PANEL UNDER COVER SUB-ASSEMBLY_ INFO

3. REMOVE FRONT BLOWER MOTOR SUB-ASSEMBLY (w/o Solar Ventilation System)

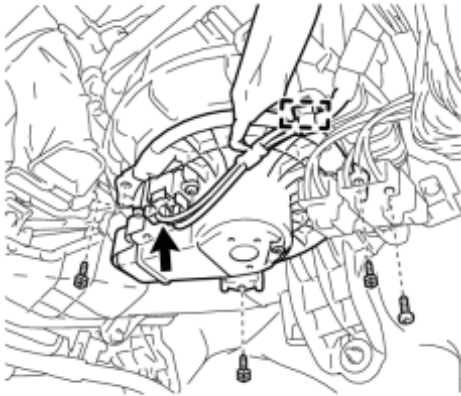

(a) Remove the quick heater connector screw.

(b) Disengage the clamp and disconnect the connector.

(c) Remove the 3 screws and front blower motor sub-assembly.

NOTICE:

Do not remove the front blower motor sub-assembly if it has been damaged or impacted.

4. REMOVE FRONT BLOWER MOTOR SUB-ASSEMBLY (w/ Solar Ventilation System)

(a) Remove the quick heater connector screw.

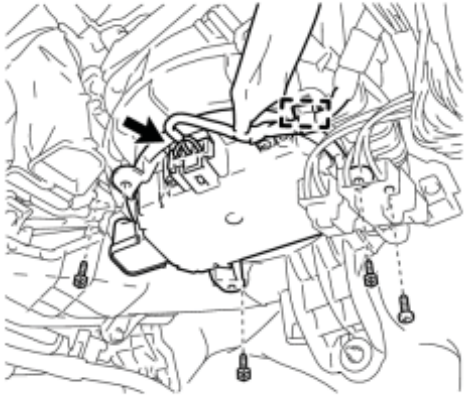

P

- (b) Disengage the clamp and disconnect the connector.
- (c) Remove the 3 screws and front blower motor sub-assembly.

NOTICE:

Do not remove the front blower motor sub-assembly if it has been damaged or impacted.

INSTALLATION

1. PRECAUTION (w/ Solar Ventilation System)

NOTICE:

Make sure to turn off the solar ventilation switch to prevent the blower motor from operating unexpectedly.

2. INSTALL FRONT BLOWER MOTOR SUB-ASSEMBLY (w/o Solar Ventilation System)

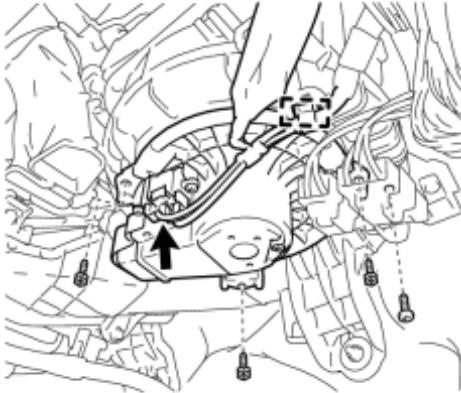

(a) Install the front blower motor sub-assembly with the 3 screws.

NOTICE:

Do not install the front blower motor sub-assembly if it has been damaged or impacted.

P

(b) Engage the clamp and connect the connector.

(c) Install the quick heater connector screw.

3. INSTALL FRONT BLOWER MOTOR SUB-ASSEMBLY (w/ Solar Ventilation System)

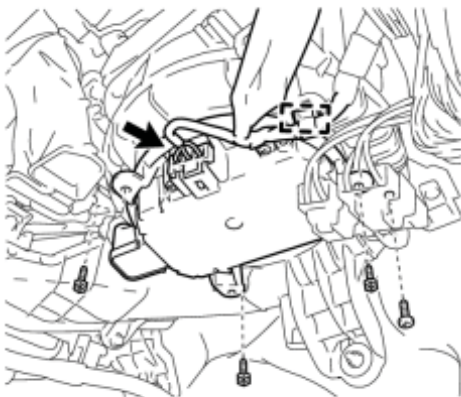

(a) Install the front blower motor sub-assembly with the 3 screws.

NOTICE:

Do not install the front blower motor sub-assembly if it has been damaged or impacted.

P

(b) Engage the clamp and connect the connector.

(c) Install the quick heater connector screw.

4. INSTALL NO. 2 INSTRUMENT PANEL UNDER COVER SUB-ASSEMBLY_ 

COMPONENTS

ILLUSTRATION

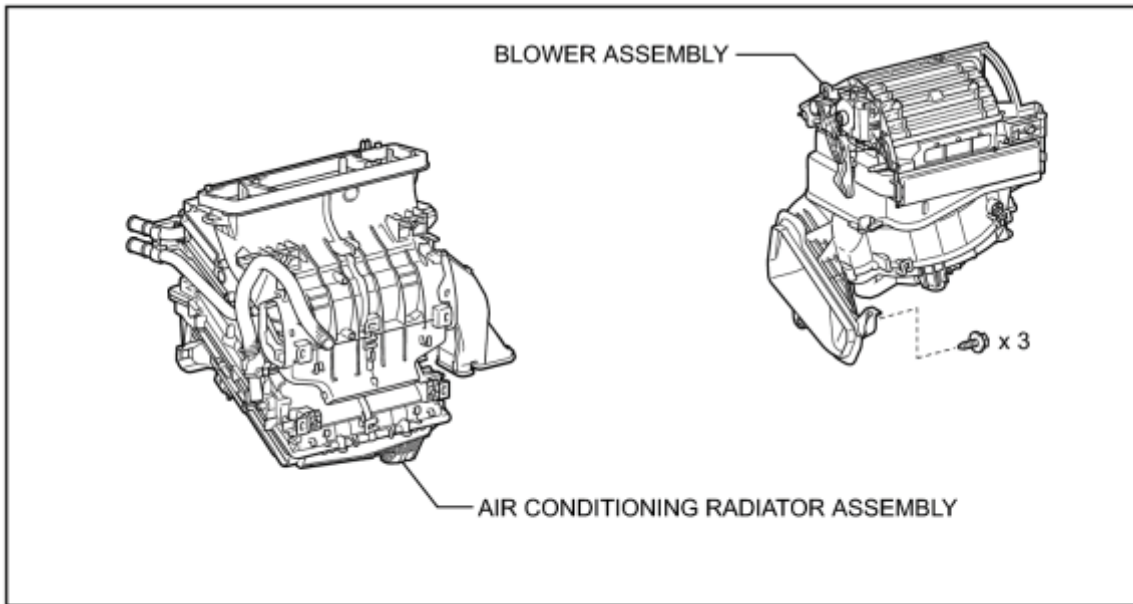
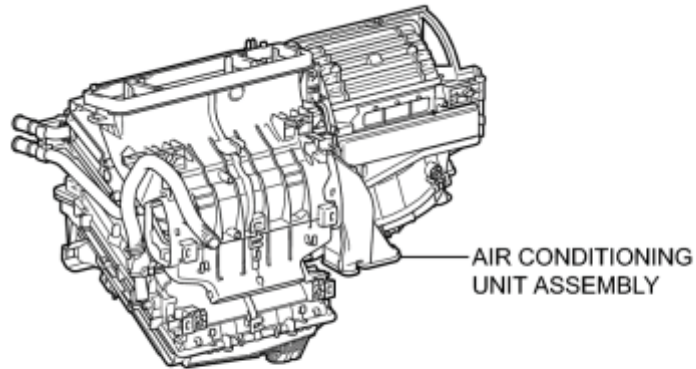

P

ILLUSTRATION

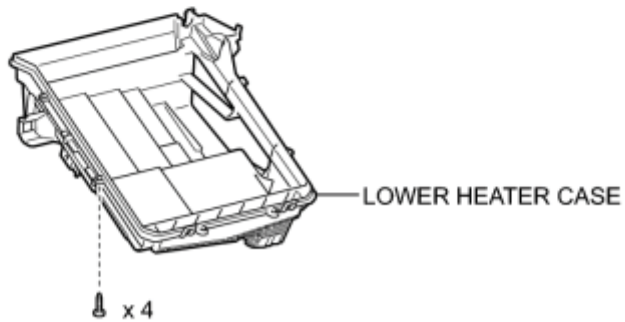
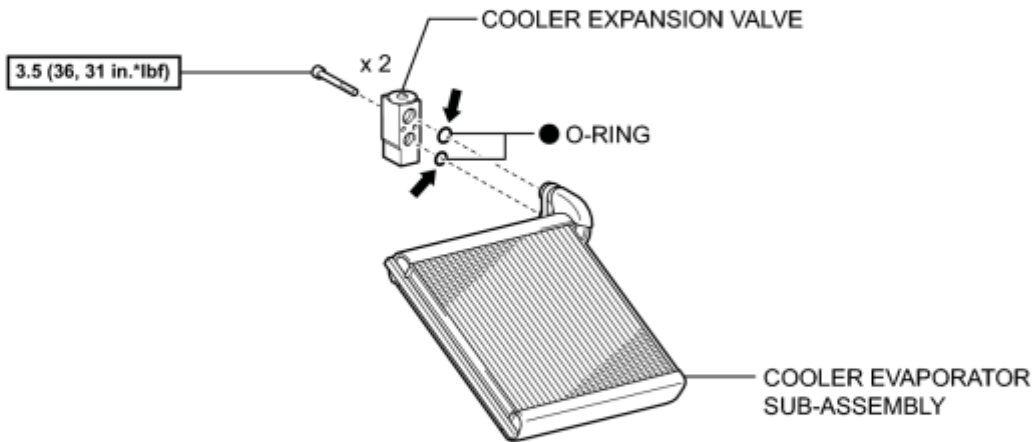
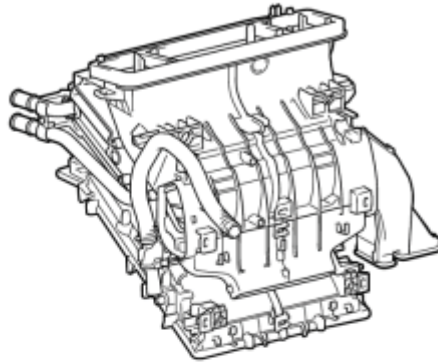

N*m (kgf*cm, ft.*lbf): Specified torque

● Non-reusable part

← Compressor oil ND-OIL 11 or equivalent

P

REMOVAL

1. REMOVE AIR CONDITIONING UNIT ASSEMBLY

HINT:

Refer to the procedure for Remove Air Conditioning Unit Assembly [INFO](#).

2. REMOVE BLOWER ASSEMBLY [INFO](#)

3. REMOVE COOLER EXPANSION VALVE [INFO](#)

4. REMOVE COOLER EVAPORATOR SUB-ASSEMBLY [INFO](#)

5. REMOVE NO. 1 COOLER THERMISTOR

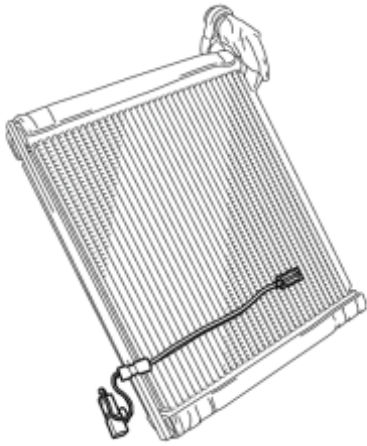

(a) Remove the No. 1 cooler thermistor.

INSPECTION

1. INSPECT EVAPORATOR TEMPERATURE SENSOR

(a) Measure the resistance according to the value(s) in the table below.

Standard Resistance:

Tester Connection	Condition	Specified Condition
1 - 2	-10°C (14°F)	7.30 to 9.10 kΩ
1 - 2	-5°C (23°F)	5.65 to 6.95 kΩ
1 - 2	0°C (32°F)	4.40 to 5.35 kΩ
1 - 2	5°C (41°F)	3.40 to 4.15 kΩ
1 - 2	10°C (50°F)	2.70 to 3.25 kΩ
1 - 2	15°C (59°F)	2.14 to 2.58 kΩ
1 - 2	20°C (68°F)	1.71 to 2.05 kΩ
1 - 2	25°C (77°F)	1.38 to 1.64 kΩ
1 - 2	30°C (86°F)	1.11 to 1.32 kΩ

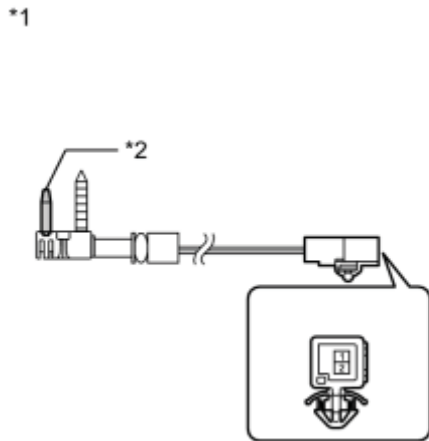

Resistance (kΩ)

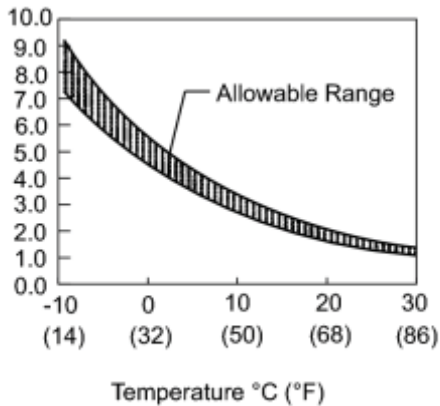

H

Text in Illustration

*1	Component without harness connected (Evaporator Temperature Sensor)
*2	Sensing Portion

- Hold the sensor only by its connector. Touching the sensor may change the resistance value.
- When measuring, the sensor temperature must be the same as the ambient temperature.

HINT:

As the temperature increases, the resistance decreases (see the graph).

If the resistance is not as specified, replace the evaporator temperature sensor.

INSTALLATION

1. INSTALL NO. 1 COOLER THERMISTOR

(a) Install the No. 1 cooler thermistor as shown in the illustration.

Part	Length	
A	175 mm	6.89 in.
B	161.6 mm	6.36 in.
C	87.9 mm	3.46 in.
D	50 mm	1.99 in.

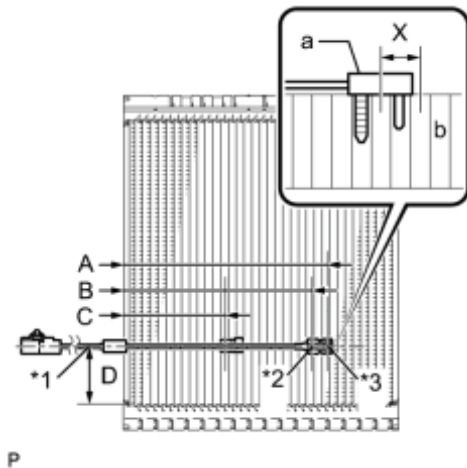

Text in Illustration

*1	From Tank
*2	Fixed Part
*3	Sensor Part

- Be sure to insert the thermistor only once because reinserting it into the same position will not allow it to be firmly secured.
- When reusing the evaporator, insert the thermistor one row next to the one that has been used previously (X in the illustration).
- After inserting the thermistor, do not apply excessive force to the wire.
- Directly insert the thermistor until the edge of plastic case "a" comes into contact with evaporator "b".

2. INSTALL COOLER EVAPORATOR SUB-ASSEMBLY_ INFO

3. INSTALL COOLER EXPANSION VALVE_ INFO

4. INSTALL BLOWER ASSEMBLY_ INFO

5. INSTALL AIR CONDITIONING UNIT ASSEMBLY

HINT:

Refer to the procedure for Install Air Conditioning Unit Assembly INFO.

COMPONENTS

ILLUSTRATION

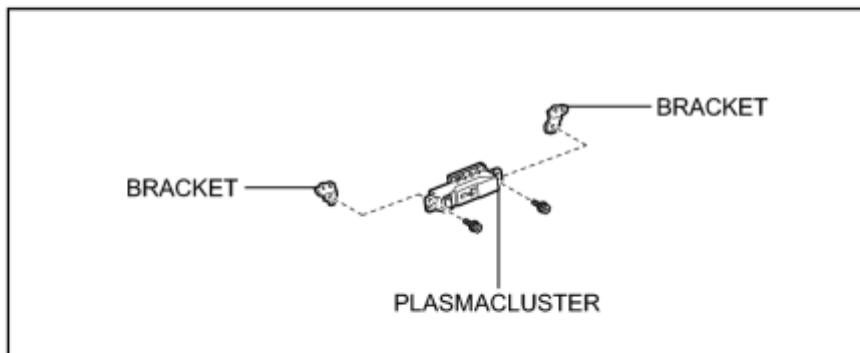
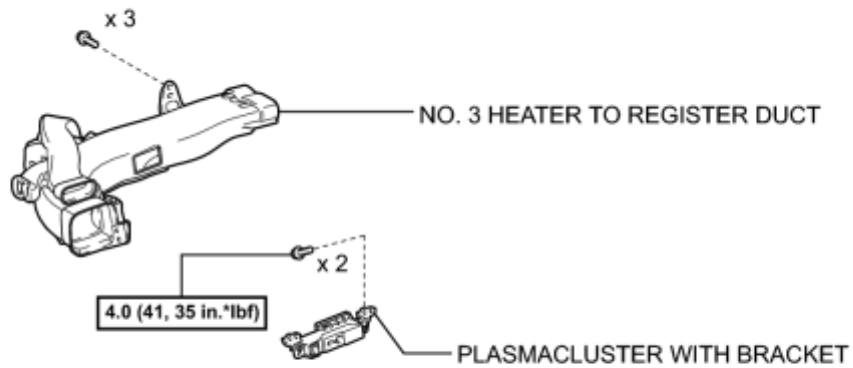
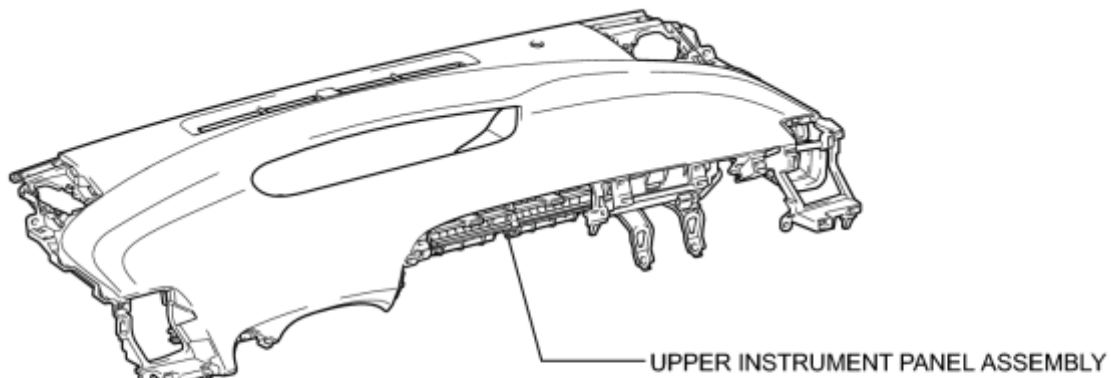

N*m (kgf*cm, ft.*lbf): Specified torque

P

REMOVAL

1. REMOVE UPPER INSTRUMENT PANEL ASSEMBLY

HINT:

Refer to the procedure for Remove Upper Instrument Panel Assembly [INFO](#).

2. REMOVE NO. 3 HEATER TO REGISTER DUCT [INFO](#)

3. REMOVE PLASMACLUSTER WITH BRACKET

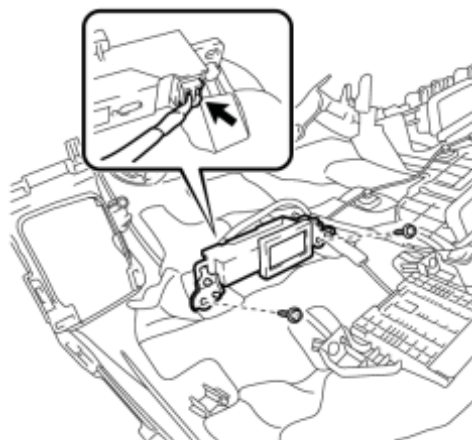

(a) Disconnect the connector.

(b) Remove the 2 screws and plasmacluster with bracket.

4. REMOVE PLASMACLUSTER



(a) Remove the 2 screws and plasmacluster from the 2 brackets.

INSTALLATION

1. INSTALL PLASMACLUSTER



(a) Install the plasmacluster with the 2 screws to the 2 brackets.

P

2. INSTALL PLASMACLUSTER WITH BRACKET

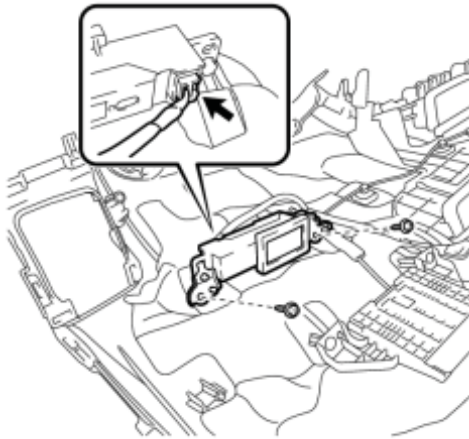

(a) Install the plasmacluster with bracket with the 2 screws.

Torque: **4.0 N·m (41 kgf·cm, 35in·lbf)**

P

(b) Connect the connector.

3. INSTALL NO. 3 HEATER TO REGISTER DUCT INFO

4. INSTALL UPPER INSTRUMENT PANEL ASSEMBLY

HINT:

Refer to the procedure for Install Upper Instrument Panel Assembly INFO.

COMPONENTS ILLUSTRATION

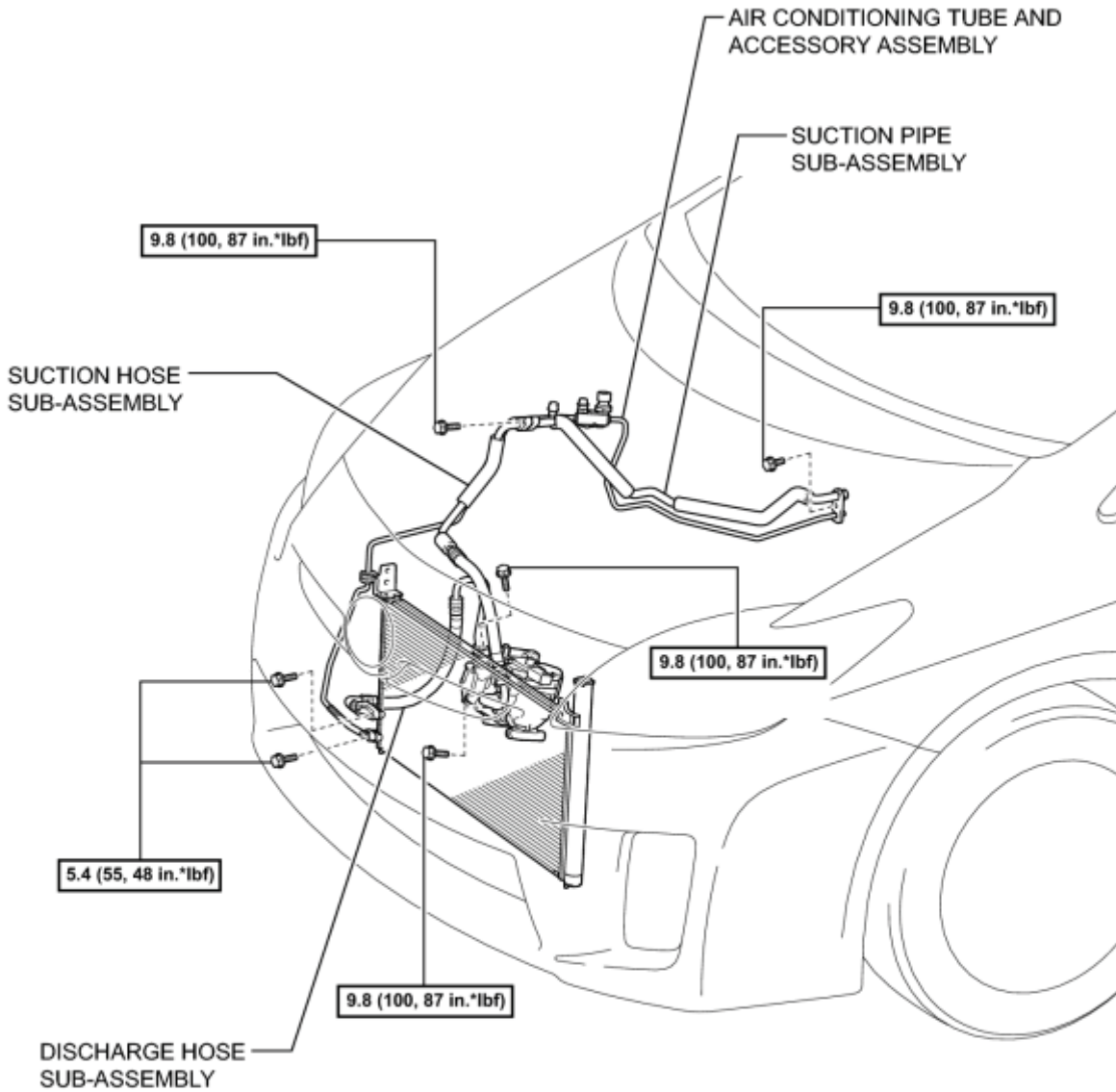

N*m (kgf*cm, ft.*lbf): Specified torque

P

ON-VEHICLE INSPECTION

1. INSPECT REFRIGERANT VOLUME

(a) Check the sight glass on the air conditioning tube and accessory.

(1) Prepare the vehicle according to the chart below.

Item	Condition
Vehicle door	Fully open
Temperature setting	MAX COOL
Blower speed	HI
A/C	on

(2) Compare the sight glass to the following chart.

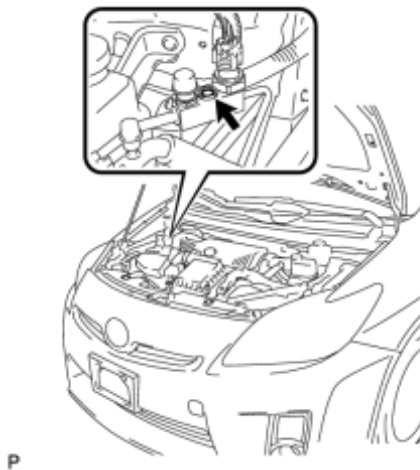

Item	Symptom	Amount of Refrigerant	Corrective Action
1	Bubbles exist	Insufficient*	<ol style="list-style-type: none"> 1. Check for gas leaks and repair if necessary 2. Recharge with a proper amount of refrigerant
2	No bubbles exist	Empty, insufficient, or excessive	Refer to 3 and 4
3	No temperature difference between compressor inlet and outlet	Empty or nearly empty	<ol style="list-style-type: none"> 1. Check for gas leaks and repair if necessary 2. Evacuate the AC system and recharge with a proper amount of refrigerant
4	Considerable temperature difference between compressor inlet and outlet	Proper or excessive	Refer to 5 and 6
5	Immediately after air conditioning is turned off, refrigerant remains clear	Excessive	<ol style="list-style-type: none"> 1. Recover refrigerant 2. Evacuate the AC system and recharge with a proper

			amount of refrigerant
6	Immediately after air conditioning is turned off, refrigerant foams and then becomes clear	Proper	-

*: Bubbles in the sight glass with the vehicle's interior temperature above 35°C (95°F) can be considered normal if cooling is sufficient.

2. INSPECT REFRIGERANT PRESSURE WITH MANIFOLD GAUGE SET

HINT:

This is a method where a manifold gauge set is used to help locate the problem.

(a) Read the manifold gauge pressure when the following conditions are met:

Test conditions:

- Temperature at the air inlet with the switch set at RECIRC is 30 to 35°C (86 to 95°F).
- The blower speed control switch position is at "HI".
- The temperature control dial position is at "COOL".
- The A/C switch is on.
- Doors are fully open.
- The power switch is in a position that enables the A/C compressor to run.

(1) Normally functioning refrigeration system

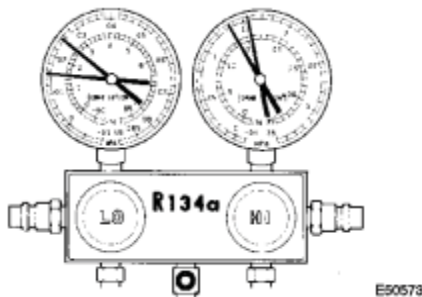

Gauge Reading

Pressure Side	Refrigerant Volume
Low	0.15 to 0.25 MPa (1.5 to 2.5 kgf/cm ² , 21 to 36 psi)
High	1.37 to 1.57 MPa (13.9 to 16.0 kgf/cm ² , 199 to 228 psi)

(2) Moisture is present in the refrigeration system.

Condition: Periodically cools and then fails to cool

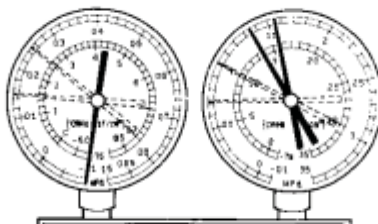

Symptom	Probable Cause	Diagnosis	Corrective Action
During operation, pressure on low pressure side cycles between normal and vacuum	<ul style="list-style-type: none"> Moisture in the AC system will freeze at the expansion valve orifice, causing the refrigeration cycle to temporarily stop After the system stops, and warms up again, the ice will melt and normal operation will be temporarily restored 	<ul style="list-style-type: none"> Cooler dryer (integrated into condenser tank) in oversaturated state Moisture in refrigeration system freezes at expansion valve orifice and blocks circulation of refrigerant 	<ol style="list-style-type: none"> Replace cooler dryer Remove moisture in system by repeatedly evacuating air Supply a proper amount of new refrigerant

(3) Insufficient cooling

Condition: Cooling system does not function effectively.

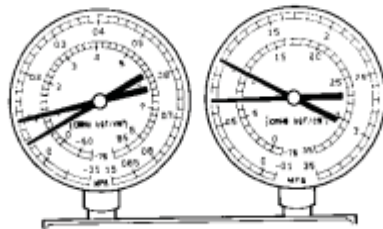

I22118

Symptom	Probable Cause	Diagnosis	Corrective Action
<ul style="list-style-type: none"> Pressure is low on both low and high pressure sides Bubbles are seen through sight glass continuously Insufficient cooling performance 	Gas leaks from the refrigeration system	<ul style="list-style-type: none"> Insufficient refrigerant Refrigerant leaking 	<ol style="list-style-type: none"> Check for gas leaks and repair if necessary Supply a proper amount of new refrigerant If the gauge indicates a pressure of close to 0, then it will be necessary to evacuate the system after repairing the leak

(4) Poor circulation of refrigerant

Condition: Cooling system does not function effectively.

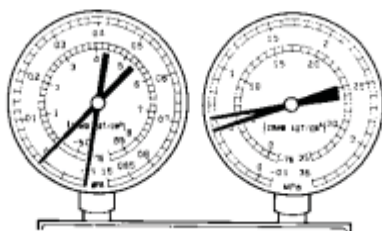

I22119

Symptom	Probable Cause	Diagnosis	Corrective Action
---------	----------------	-----------	-------------------

Symptom	Probable Cause	Diagnosis	Corrective Action
<ul style="list-style-type: none"> Pressure is low on both low and high pressure sides Frost exists on pipe from condenser to unit 	Refrigerant flow is obstructed by dirt inside the pipes of the condenser core	Receiver is clogged	Replace condenser

(5) Refrigerant does not circulate.

Condition: Cooling system does not function. (Sometimes it may function.)

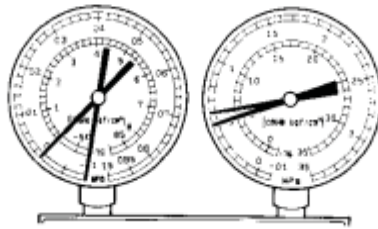

I22120

Symptom	Probable Cause	Diagnosis	Corrective Action
<ul style="list-style-type: none"> Vacuum is indicated on low pressure side and very low pressure is indicated on high pressure side Frost or condensation is seen on piping on both sides of receiver/drier or expansion valve 	<ul style="list-style-type: none"> Refrigerant flow is obstructed by moisture or dirt in refrigeration system Refrigerant flow is disrupted by gas leaks internally through the expansion valve 	Refrigerant does not circulate	<ol style="list-style-type: none"> Check expansion valve Replace expansion valve Replace condenser Evacuate air and supply a proper amount of new refrigerant For internal gas leaks at expansion valve, replace expansion valve

(6) Refrigerant is overcharged or cooling effectiveness of condenser is insufficient.

Condition: Cooling system does not function.

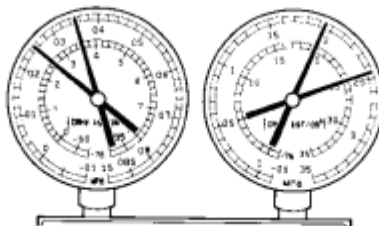

I22121

Symptom	Probable Cause	Diagnosis	Corrective Action
<ul style="list-style-type: none"> Pressure is too 	<ul style="list-style-type: none"> Unable to develop 	<ul style="list-style-type: none"> Excessive refrigerant 	<ol style="list-style-type: none"> Clean condenser

Symptom	Probable Cause	Diagnosis	Corrective Action
high on both low and high pressure sides <ul style="list-style-type: none"> No air bubbles are seen through sight glass even when compressor is on 	sufficient performance due to excessive use of refrigeration system <ul style="list-style-type: none"> Cooling effectiveness of condenser is insufficient 	in cycle → excessive refrigerant was added during recharging <ul style="list-style-type: none"> Condenser cooling effectiveness is insufficient → condenser fins are clogged at cooling fan 	<ol style="list-style-type: none"> Check the operation of the condenser cooling fan If 1 and 2 are normal state, check the amount of refrigerant and supply a proper amount of refrigerant

(7) Air is present in the refrigeration system.

Condition: Cooling system does not function.

NOTE: These gauge indications occur when the refrigeration system opens and the refrigerant is charged without vacuum purging.

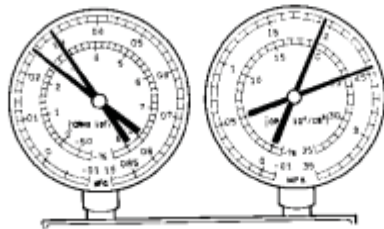

Symptom	Probable Cause	Diagnosis	Corrective Action
<ul style="list-style-type: none"> Pressure is too high on both low and high pressure sides The low pressure piping is too hot to touch Bubbles can be seen through sight glass 	Air in system	<ul style="list-style-type: none"> Air present in refrigeration system Insufficient vacuum purging 	<ol style="list-style-type: none"> Check compressor oil to see if it is dirty or insufficient Evacuate the system and recharge it with new or purified refrigerant

(8) Expansion valve malfunction

Condition: Insufficient cooling

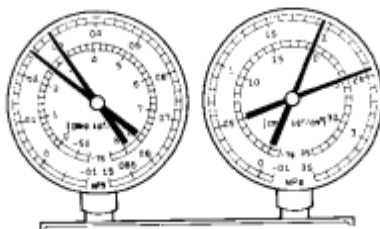

I22123

Symptom	Probable Cause	Diagnosis	Corrective Action
---------	----------------	-----------	-------------------

Symptom	Probable Cause	Diagnosis	Corrective Action
<ul style="list-style-type: none"> Pressure is too high on both low and high pressure sides Frost or a large amount of condensation on piping on low pressure side 	Expansion valve may be stuck	<ul style="list-style-type: none"> Excessive refrigerant in low pressure piping Expansion valve opened too wide 	Check expansion valve

(9) Insufficient compressor compression

Condition: Insufficient cooling

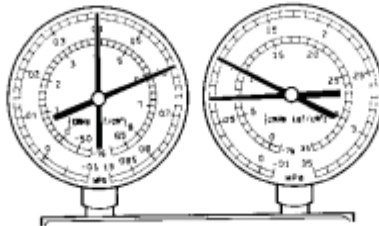

Symptom	Probable Cause	Diagnosis	Corrective Action
<ul style="list-style-type: none"> Pressure is too high on both low and high pressure sides Pressure is too low on high pressure side 	Internal leak in compressor	<ul style="list-style-type: none"> Low compression Leak from a damaged valve, or parts may be broken 	Replace compressor

Gauge readings (Reference)

Pressure on low pressure side

MPa (kgf/cm², psi)

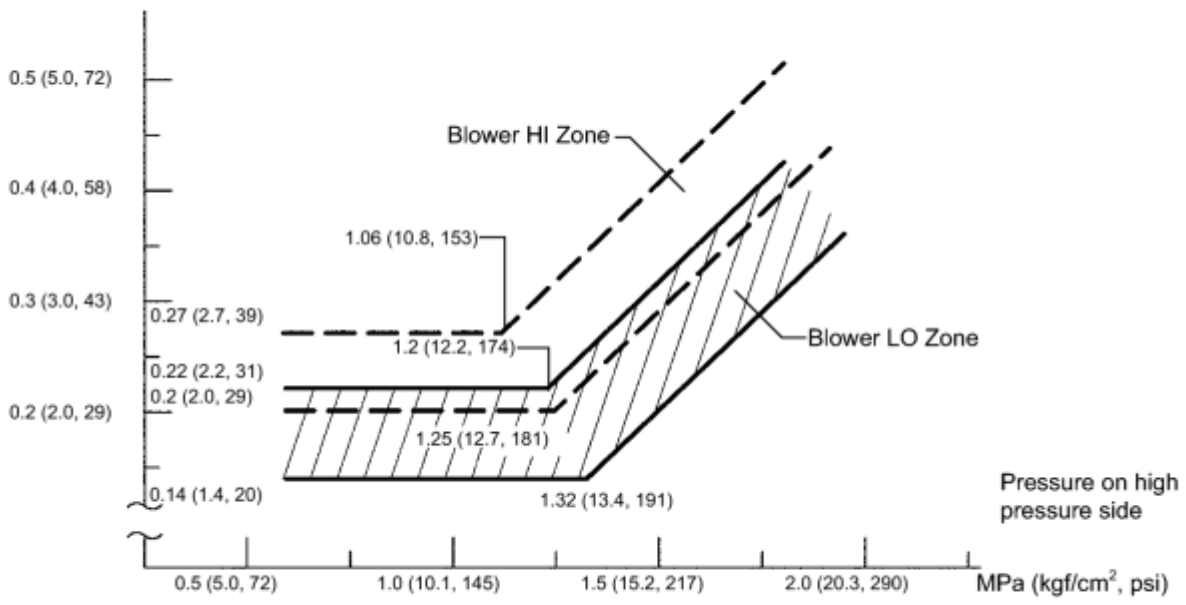

REPLACEMENT

1. RECOVER REFRIGERANT FROM REFRIGERATION SYSTEM

(a) Turn the A/C switch on.

(b) Operate the A/C with the setting temperature at 25°C (77°F) and the blower level at LO for 10 minutes to circulate the refrigerant. This causes most of the compressor oil from the various components of the A/C system to collect in the A/C compressor.

(c) Turn the power switch off.

(d) Recover the refrigerant from the A/C system using a refrigerant recovery unit.

2. CHARGE WITH REFRIGERANT

(a) Perform vacuum purging using a vacuum pump.

(b) Charge with refrigerant HFC-134a (R134a).

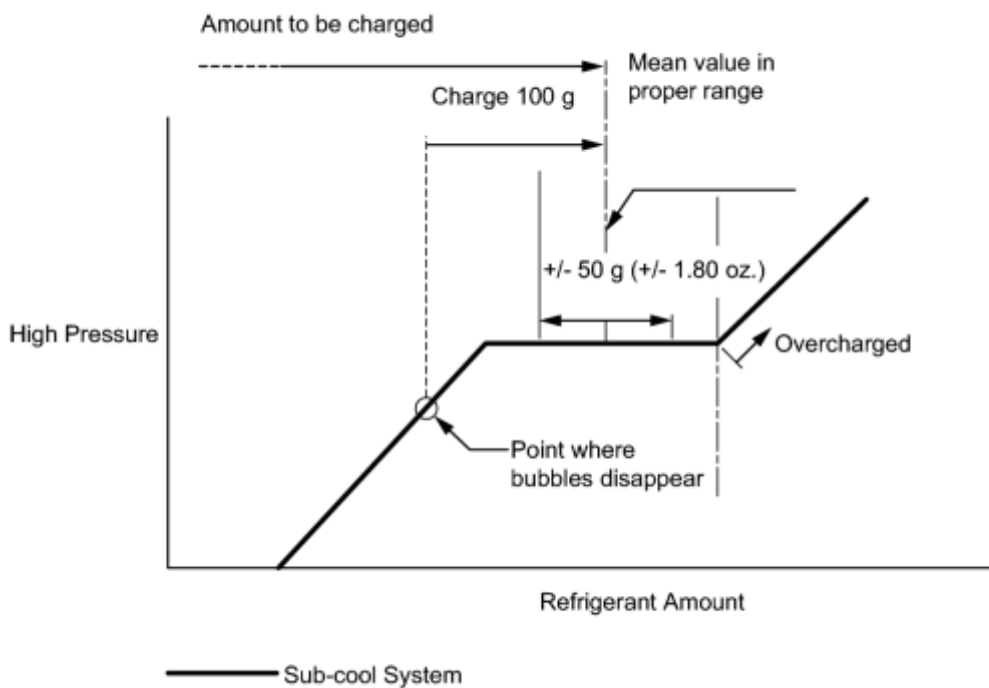

P

Standard:

470 g (16.6 oz.)

SST: 09985-20010

09985-02010

09985-02050

09985-02060

09985-02070

09985-02080

09985-02090

09985-02110

09985-02130

09985-02140

09985-02150

NOTICE:

- Do not turn the A/C on before charging with refrigerant. Doing so will cause the compressor to work without refrigerant, resulting in overheating of the cooler compressor.
- Approximately 100 g (3.53 oz.) of refrigerant may need to be charged after bubbles disappear. The refrigerant amount should be checked by quantity, not with the sight glass.
- Avoid using the gauge manifold set that had been used for vehicles with conventional compressor oil (ND-OIL11 or equivalent) as much as possible. This will cause compressor oil remaining in the manifold to enter the vehicle, resulting in insulation performance deterioration. A gauge manifold set that had been used 3 times or less can be reused if an appropriate one is not available.

HINT:

Ensure that sufficient refrigerant is available to recharge the system when using a refrigerant recovery unit. Refrigerant recovery units are not always able to recover 100% of the refrigerant from an A/C system.

3. WARM UP COMPRESSOR

- (a) Keep the A/C switch on for at least 2 minutes to warm up the compressor.

NOTICE:

Be sure to warm up the compressor when turning the A/C on after removing and installing the cooler refrigerant lines (including the compressor), to prevent damage to the compressor.

4. INSPECT FOR REFRIGERANT LEAK

- (a) After recharging with refrigerant, inspect for refrigerant leaks using a halogen leak detector.
- (b) Carry out the test under the following conditions:

- Turn the power switch off.
- Secure good ventilation (the halogen leak detector may react to volatile gases which are not refrigerant, such as evaporated gasoline and exhaust gas).
- Repeat the test 2 or 3 times.
- Make sure that there is some refrigerant remaining in the refrigeration system.

When the compressor is off: approx. 392 to 588 kPa (3.9 to 5.9 kgf/cm², 57 to 85 psi)

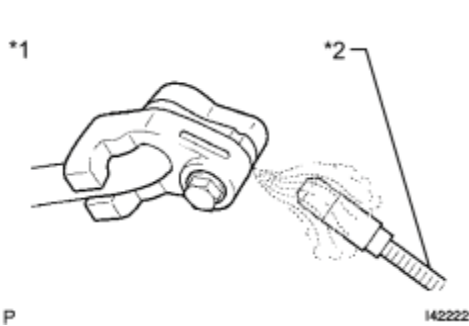

(c) Using a halogen leak detector, inspect for refrigerant leaks from the refrigerant lines.

Text in Illustration

*1	Inspect for Leak
*2	Halogen Leak Detector

(d) Bring the halogen leak detector close to the drain hose with the detector's power off, and then turn the detector on.

Text in Illustration

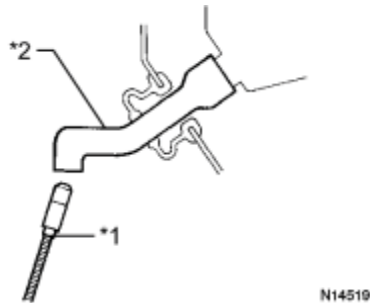

*1	Halogen Leak Detector
*2	Drain Hose

- After the blower motor has stopped, let the cooling unit stand for more than 15 minutes.
- Bring the halogen leak detector sensor under the drain hose.
- When bringing the halogen leak detector close to the drain hose, make sure that the halogen leak detector does not react to volatile gases. If it is not possible to avoid interference from volatile gases, the vehicle should be lifted up to allow testing.

(e) If a refrigerant leak is not detected from the drain hose, remove the blower motor control from the cooling unit. Insert the halogen leak detector sensor into the unit and perform the test.

(f) Disconnect the pressure switch connector and leave it for approximately 20 minutes. Bring the halogen leak detector close to the pressure switch and perform the test.

COMPONENTS

ILLUSTRATION

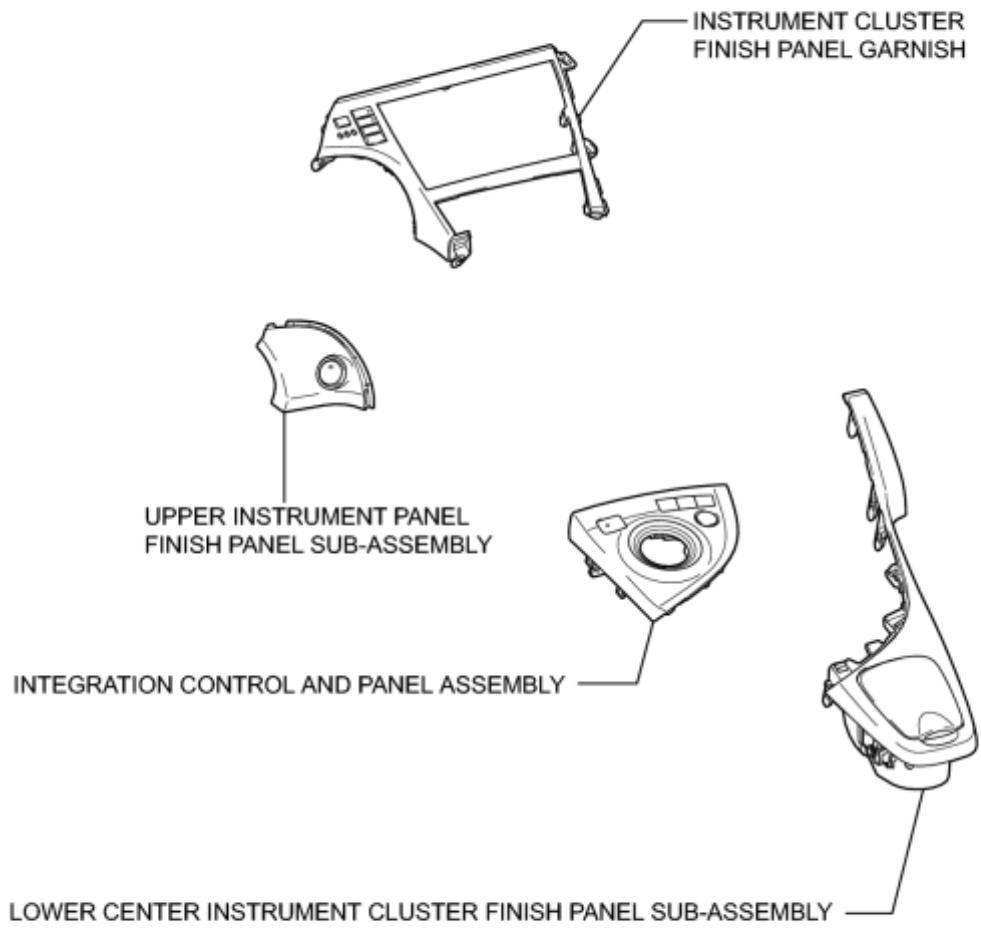

P

ILLUSTRATION

w/ Power Outlet Socket:

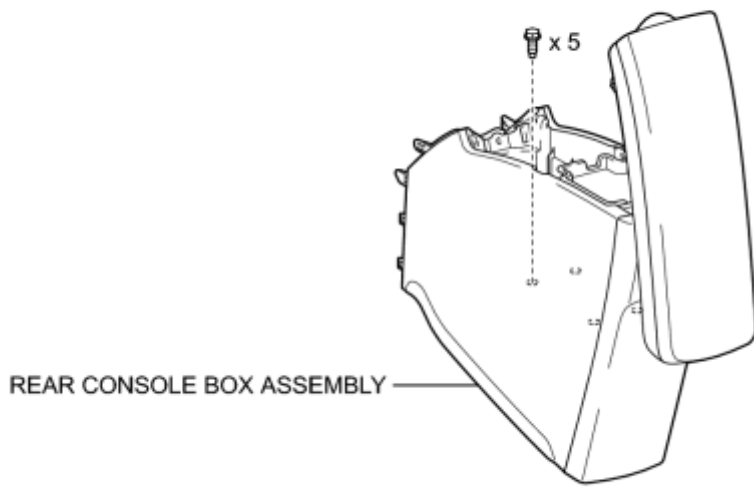
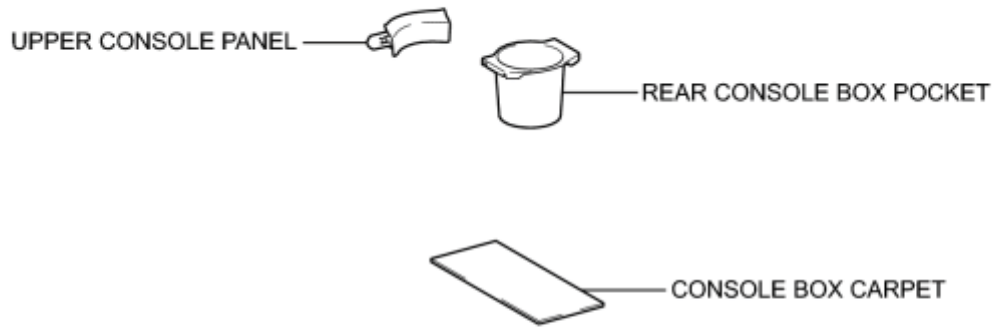

P

ILLUSTRATION

w/o Power Outlet Socket:

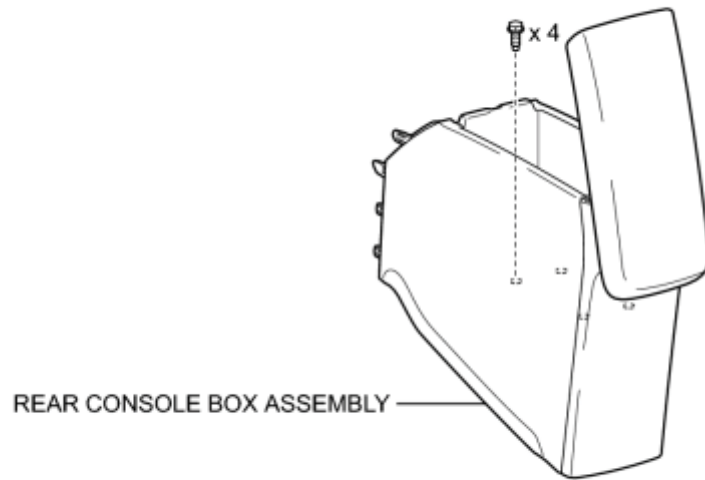

P

ILLUSTRATION

AIR CONDITIONING CONTROL ASSEMBLY



SHIFT LOCK CONTROL UNIT ASSEMBLY

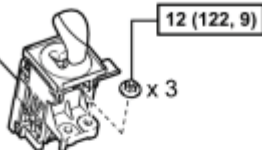

ROOM TEMPERATURE SENSOR

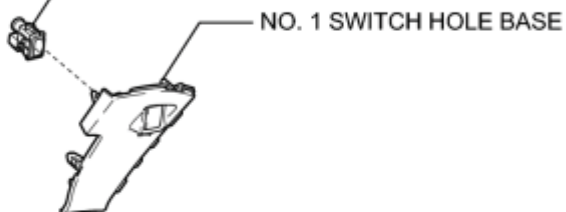

NO. 1 SWITCH HOLE BASE

FRONT NO. 1 CONSOLE BOX INSERT

FRONT NO. 2 CONSOLE BOX INSERT



BOX BOTTOM MAT

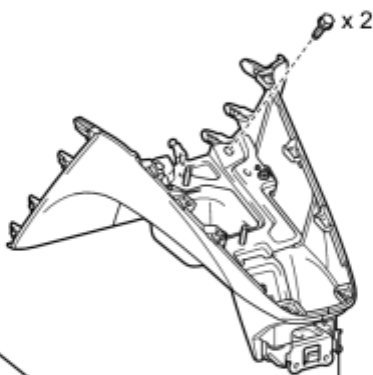

UPPER INSTRUMENT PANEL FINISH PANEL ASSEMBLY

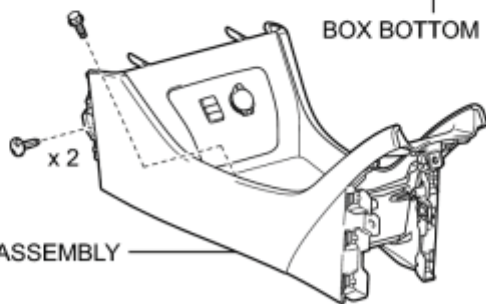

CONSOLE BOX ASSEMBLY

NO. 2 CONSOLE BOX MOUNTING BRACKET

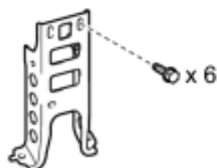

ELECTRICAL KEY OSCILLATOR



[N*m (kgf*cm, ft.*lbf)]: Specified torque

P

REMOVAL

1. REMOVE INTEGRATION CONTROL AND PANEL ASSEMBLY_ [INFO](#)
2. REMOVE LOWER CENTER INSTRUMENT CLUSTER FINISH PANEL SUB-ASSEMBLY_ [INFO](#)
3. REMOVE INSTRUMENT CLUSTER FINISH PANEL GARNISH_ [INFO](#)
4. REMOVE UPPER INSTRUMENT PANEL FINISH PANEL SUB-ASSEMBLY_ [INFO](#)
5. REMOVE REAR CONSOLE BOX POCKET (w/ Power Outlet Socket)_ [INFO](#)
6. REMOVE UPPER CONSOLE PANEL (w/ Power Outlet Socket)_ [INFO](#)
7. REMOVE CONSOLE BOX CARPET_ [INFO](#)
8. REMOVE REAR CONSOLE BOX ASSEMBLY (w/ Power Outlet Socket)_ [INFO](#)
9. REMOVE REAR CONSOLE BOX ASSEMBLY (w/o Power Outlet Socket)_ [INFO](#)
10. REMOVE ELECTRICAL KEY OSCILLATOR_ [INFO](#)
11. REMOVE NO. 2 CONSOLE BOX MOUNTING BRACKET_ [INFO](#)
12. REMOVE FRONT NO. 1 CONSOLE BOX INSERT_ [INFO](#)
13. REMOVE FRONT NO. 2 CONSOLE BOX INSERT_ [INFO](#)
14. REMOVE BOX BOTTOM MAT_ [INFO](#)
15. SEPARATE CONSOLE BOX ASSEMBLY_ [INFO](#)
16. REMOVE AIR CONDITIONING CONTROL ASSEMBLY_ [INFO](#)
17. REMOVE SHIFT LOCK CONTROL UNIT ASSEMBLY_ [INFO](#)
18. REMOVE UPPER INSTRUMENT PANEL FINISH PANEL ASSEMBLY_ [INFO](#)
19. REMOVE NO. 1 SWITCH HOLE BASE_ [INFO](#)
20. REMOVE ROOM TEMPERATURE SENSOR
 - (a) Disengage the 2 claws and remove the room temperature sensor from the No. 1 switch hole base.

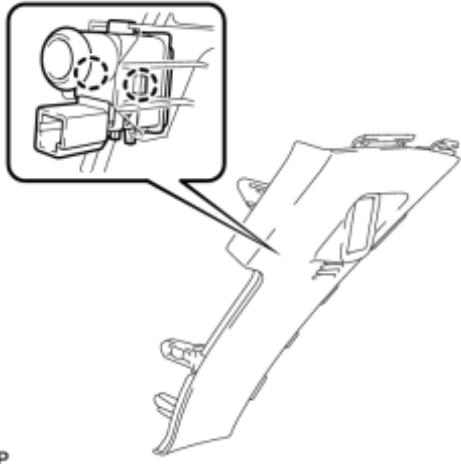

P

INSPECTION

1. INSPECT ROOM TEMPERATURE SENSOR

(a) Measure the resistance according to the value(s) in the table below.

Standard Resistance:

Tester Connection	Condition	Specified Condition
1 - 2	10°C (50°F)	3.00 to 3.73 kΩ
1 - 2	15°C (59°F)	2.45 to 2.88 kΩ
1 - 2	20°C (68°F)	1.95 to 2.30 kΩ
1 - 2	25°C (77°F)	1.60 to 1.80 kΩ
1 - 2	30°C (86°F)	1.28 to 1.47 kΩ
1 - 2	35°C (95°F)	1.00 to 1.22 kΩ
1 - 2	40°C (104°F)	0.80 to 1.00 kΩ
1 - 2	45°C (113°F)	0.65 to 0.85 kΩ
1 - 2	50°C (122°F)	0.50 to 0.70 kΩ
1 - 2	55°C (131°F)	0.44 to 0.60 kΩ
1 - 2	60°C (140°F)	0.36 to 0.50 kΩ

*1

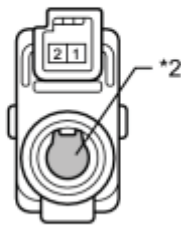

Resistance (kΩ)

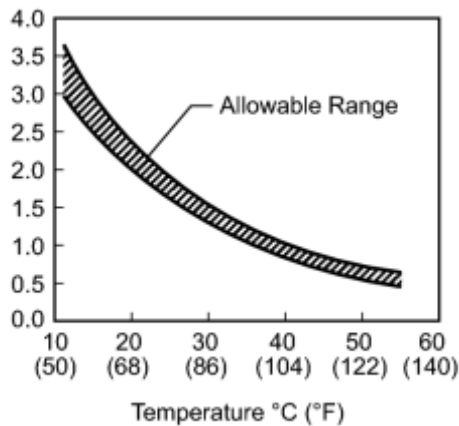

Text in Illustration

*1	Component without harness connected (Room Temperature Sensor)
*2	Sensing Portion

- Hold the sensor only by its connector. Touching the sensor may change the resistance value.
- When measuring, the sensor temperature must be the same as the ambient temperature.

HINT:

As the temperature increases, the resistance decreases (see the graph).

If the resistance is not as specified, replace the room temperature sensor.

INSTALLATION

1. INSTALL ROOM TEMPERATURE SENSOR

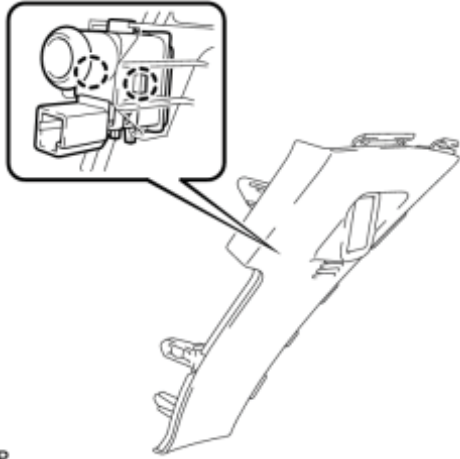

(a) Engage the 2 claws to install the room temperature sensor to the No. 1 switch hole base.

2. INSTALL NO. 1 SWITCH HOLE BASE_ [INFO](#)

3. INSTALL UPPER INSTRUMENT PANEL FINISH PANEL ASSEMBLY_ [INFO](#)

4. INSTALL SHIFT LOCK CONTROL UNIT ASSEMBLY_ [INFO](#)

5. INSTALL AIR CONDITIONING CONTROL ASSEMBLY_ [INFO](#)

6. INSTALL CONSOLE BOX ASSEMBLY_ [INFO](#)

7. INSTALL BOX BOTTOM MAT_ [INFO](#)

8. INSTALL FRONT NO. 2 CONSOLE BOX INSERT_ [INFO](#)

9. INSTALL FRONT NO. 1 CONSOLE BOX INSERT_ [INFO](#)

10. INSTALL NO. 2 CONSOLE BOX MOUNTING BRACKET_ [INFO](#)

11. INSTALL ELECTRICAL KEY OSCILLATOR_ [INFO](#)

12. INSTALL REAR CONSOLE BOX ASSEMBLY (w/ Power Outlet Socket)_ [INFO](#)

13. INSTALL REAR CONSOLE BOX ASSEMBLY (w/o Power Outlet Socket)_ [INFO](#)

14. INSTALL CONSOLE BOX CARPET_ [INFO](#)

15. INSTALL UPPER CONSOLE PANEL (w/ Power Outlet Socket)_ [INFO](#)

16. INSTALL REAR CONSOLE BOX POCKET (w/ Power Outlet Socket)_ [INFO](#)

17. INSTALL UPPER INSTRUMENT PANEL FINISH PANEL SUB-ASSEMBLY_ [INFO](#)

18. INSTALL INSTRUMENT CLUSTER FINISH PANEL GARNISH_ [INFO](#)

19. INSTALL LOWER CENTER INSTRUMENT CLUSTER FINISH PANEL SUB-ASSEMBLY_ [INFO](#)

20. INSTALL INTEGRATION CONTROL AND PANEL ASSEMBLY_ [INFO](#)

21. INSPECT SHIFT LEVER_ [INFO](#)

COMPONENTS

ILLUSTRATION

SOLAR SENSOR —————

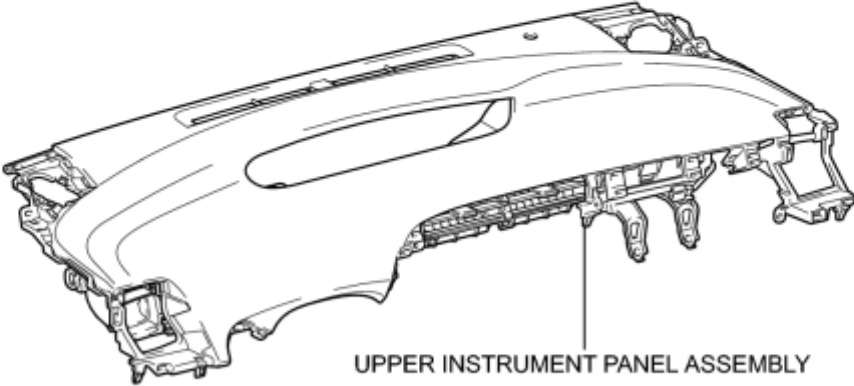

P

REMOVAL

1. REMOVE UPPER INSTRUMENT PANEL ASSEMBLY

HINT:

Refer to the procedure for Remove Upper Instrument Panel Assembly [INFO](#).

2. REMOVE SOLAR SENSOR

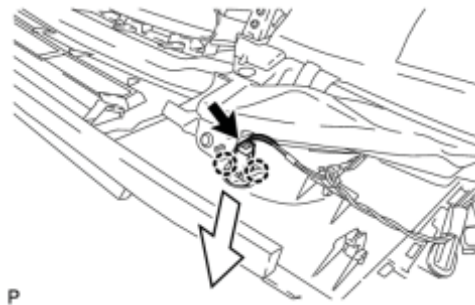

(a) Disconnect the connector.

(b) Disengage the 2 claws and remove the solar sensor as shown in the illustration.

INSPECTION

1. INSPECT SOLAR SENSOR

*1

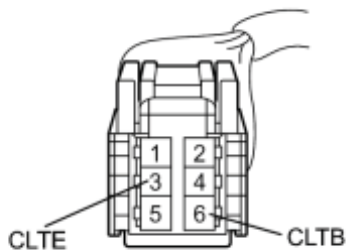

(a) Disconnect the solar sensor connector.

(b) Measure the voltage according to the value(s) in the table below.

Standard Voltage:

Tester Connection	Condition	Specified Condition
6 (CLTB) - 3 (CLTE)	Power switch off	Below 1 V
6 (CLTB) - 3 (CLTE)	Power switch on (IG)	11 to 14 V

Text in Illustration

*1	Front view of wire harness connector (to Solar Sensor)
----	---

If the voltage is not as specified, repair or replace the wire harness or connector.

(c) Reconnect the solar sensor connector.

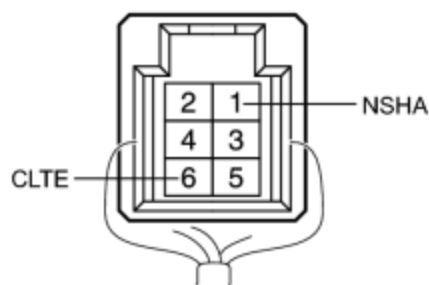

(d) Turn the power switch on (IG).

(e) Measure the voltage according to the value(s) in the table below.

Standard Voltage:

Tester Connection	Condition	Specified Condition
1 (NSHA) - 6 (CLTE)	Sensor is exposed to electric light	0.8 to 4.3 V
1 (NSHA) - 6 (CLTE)	Sensor is covered with a cloth	Below 0.8 V

Text in Illustration

*1	Component with harness connected (Solar Sensor)
----	--

NOTICE:

- The connection procedure for using a digital tester such as a TOYOTA electrical tester is shown above. When using an analog tester, connect the positive (+) lead to terminal 6 and the negative (-) lead to terminal 1 of the solar sensor.
- While using the battery during inspection, do not bring the positive and negative tester probes too close to each other as a short circuit may occur.

HINT:

- Use an incandescent light for inspection. Bring it within about 30 cm (11.8 in.) of the solar sensor.
- As the inspection light is moved away from the sensor, the voltage decreases.

If the voltage is not as specified, replace the solar sensor.

INSTALLATION

1. INSTALL SOLAR SENSOR

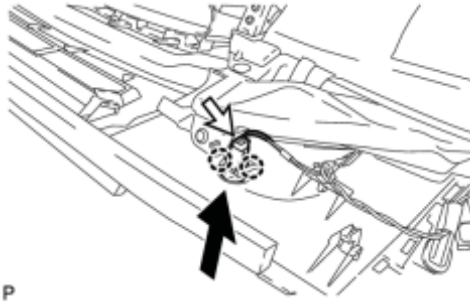

(a) Engage the 2 claws to install the solar sensor as shown in the illustration.

(b) Connect the connector.

2. INSTALL UPPER INSTRUMENT PANEL ASSEMBLY

HINT:

Refer to the procedure for Install Upper Instrument Panel Assembly [INFC](#).

COMPONENTS

ILLUSTRATION

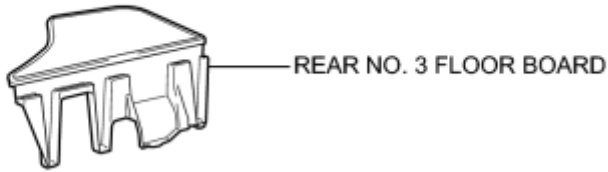

for Integrated Type:

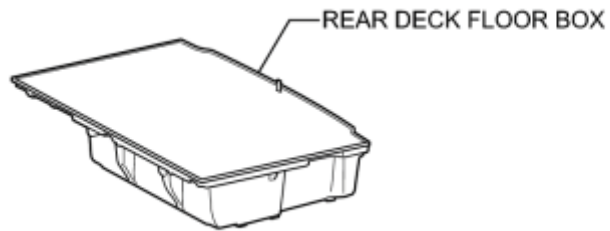

for Separate Type:

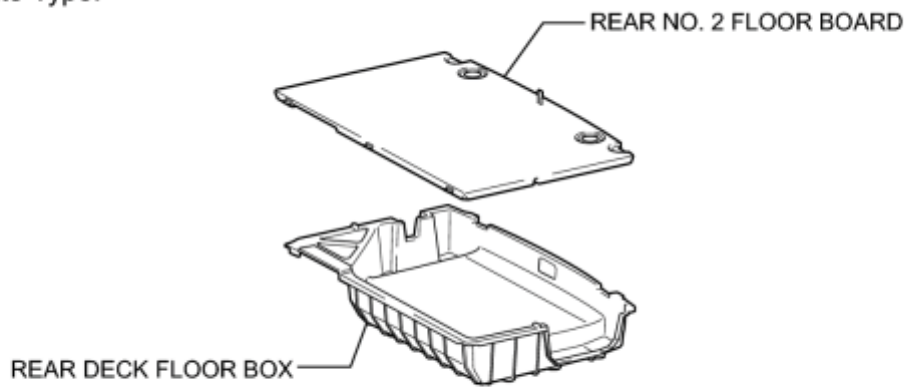

P

ILLUSTRATION

w/ Navigation System:

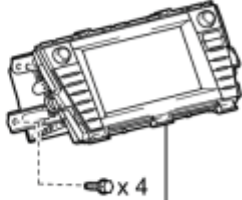

NAVIGATION RECEIVER WITH BRACKET

w/o Navigation System:

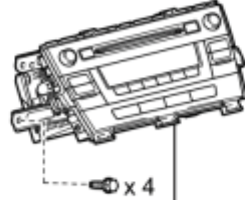

RADIO RECEIVER WITH BRACKET

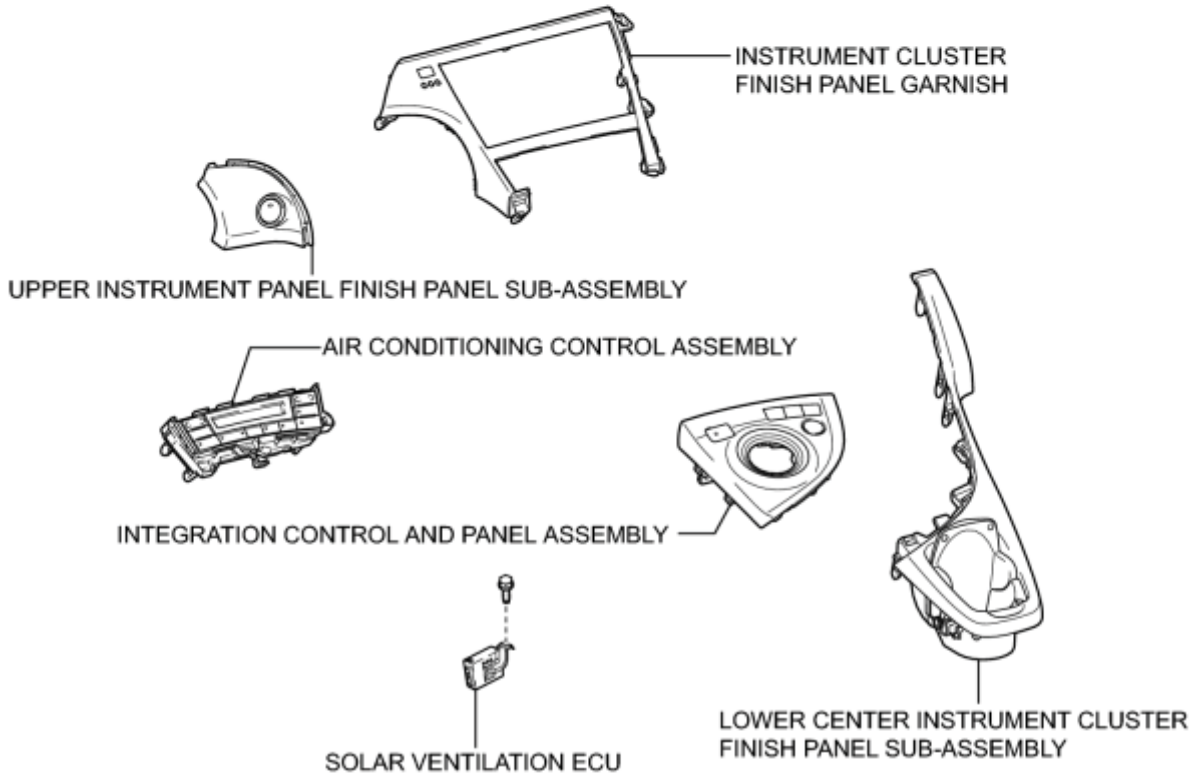

P

REMOVAL

1. REMOVE REAR NO. 2 FLOOR BOARD (for Separate Type) INFO

2. REMOVE REAR DECK FLOOR BOX INFO

3. REMOVE REAR NO. 3 FLOOR BOARD INFO

4. DISCONNECT CABLE FROM NEGATIVE BATTERY TERMINAL

NOTICE:

When disconnecting the cable, some systems need to be initialized after the cable is reconnected INFO.

5. REMOVE INTEGRATION CONTROL AND PANEL ASSEMBLY INFO

6. REMOVE LOWER CENTER INSTRUMENT CLUSTER FINISH PANEL SUB-ASSEMBLY INFO

7. REMOVE INSTRUMENT CLUSTER FINISH PANEL GARNISH INFO

8. REMOVE UPPER INSTRUMENT PANEL FINISH PANEL SUB-ASSEMBLY INFO

9. REMOVE RADIO RECEIVER WITH BRACKET (w/o Navigation System) INFO

10. REMOVE NAVIGATION RECEIVER WITH BRACKET (w/ Navigation System) INFO

11. REMOVE AIR CONDITIONING CONTROL ASSEMBLY INFO

12. REMOVE SOLAR VENTILATION ECU



(a) Remove the bolt.

P

(b) Disconnect the connector to remove the solar ventilation ECU.

INSTALLATION

1. INSTALL SOLAR VENTILATION ECU



(a) Connect the connector.

P

(b) Install the solar ventilation ECU with the bolt.

2. INSTALL AIR CONDITIONING CONTROL ASSEMBLY_ [INFO](#)

3. INSTALL RADIO RECEIVER WITH BRACKET (w/o Navigation System)_ [INFO](#)

4. INSTALL NAVIGATION RECEIVER WITH BRACKET (w/ Navigation System)_ [INFO](#)

5. INSTALL UPPER INSTRUMENT PANEL FINISH PANEL SUB-ASSEMBLY_ [INFO](#)

6. INSTALL INSTRUMENT CLUSTER FINISH PANEL GARNISH_ [INFO](#)

7. INSTALL LOWER CENTER INSTRUMENT CLUSTER FINISH PANEL SUB-ASSEMBLY_ [INFO](#)

8. INSTALL INTEGRATION CONTROL AND PANEL ASSEMBLY_ [INFO](#)

9. CONNECT CABLE TO NEGATIVE BATTERY TERMINAL

NOTICE:

When disconnecting the cable, some systems need to be initialized after the cable is reconnected [INFO](#).

10. INSTALL REAR NO. 3 FLOOR BOARD_ [INFO](#)

11. INSTALL REAR DECK FLOOR BOX_ [INFO](#)

12. INSTALL REAR NO. 2 FLOOR BOARD (for Separate Type)_ [INFO](#)

COMPONENTS

ILLUSTRATION

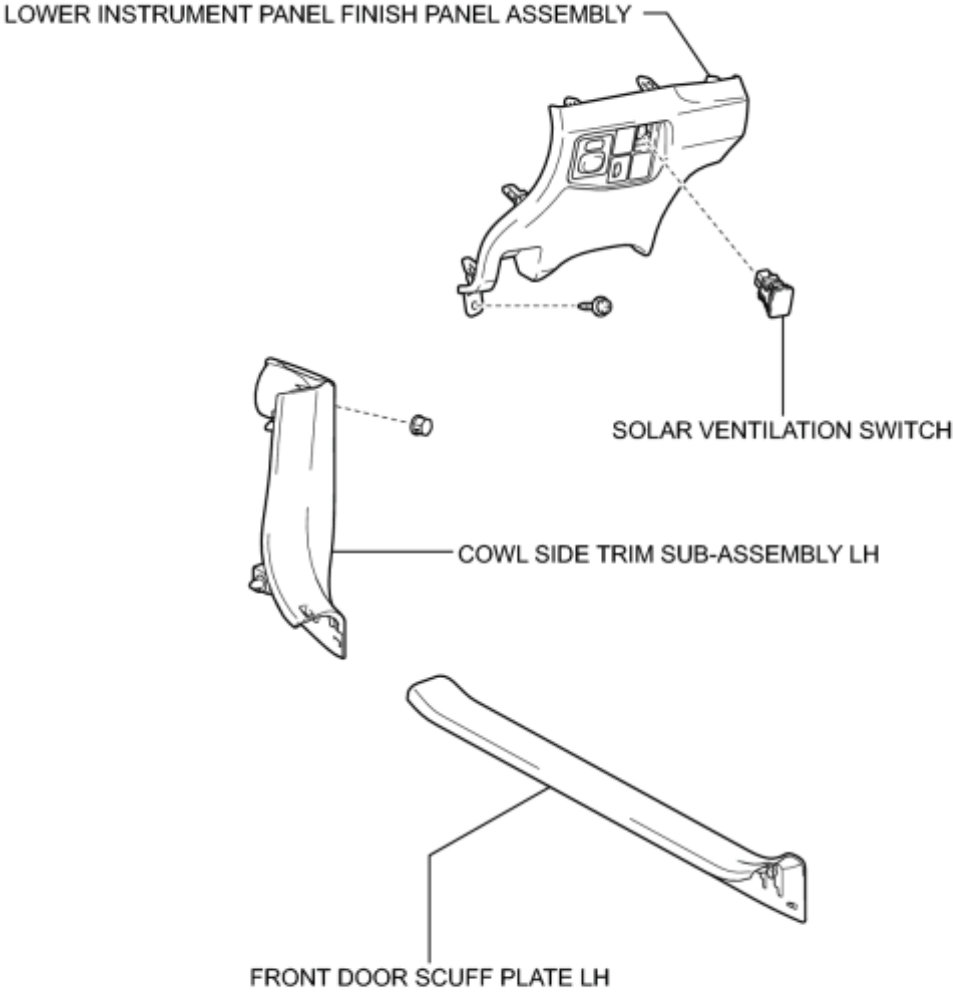

P

REMOVAL

1. REMOVE FRONT DOOR SCUFF PLATE LH_ [INFO](#)
2. REMOVE COWL SIDE TRIM SUB-ASSEMBLY LH_ [INFO](#)
3. REMOVE LOWER INSTRUMENT PANEL FINISH PANEL ASSEMBLY_ [INFO](#)
4. REMOVE SOLAR VENTILATION SWITCH

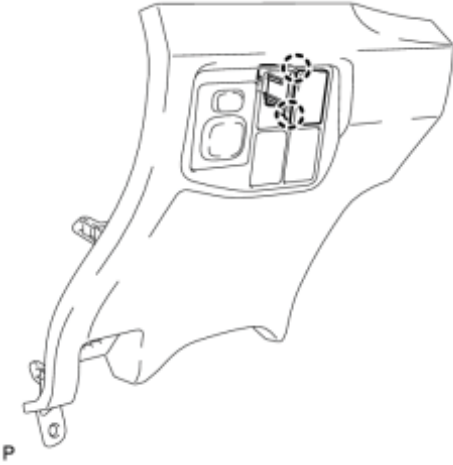

(a) Disengage the 2 claws and remove the solar ventilation switch.

INSPECTION

1. INSPECT SOLAR VENTILATION SWITCH

*1



(a) Measure the resistance according to the value(s) in the table below.

Standard Resistance:

Tester Connection	Condition	Specified Condition
9 (SW+) - 6 (SW-)	Solar ventilation switch: off	10 k Ω or higher
9 (SW+) - 6 (SW-)	Solar ventilation switch: on	Below 1 Ω

Text in Illustration

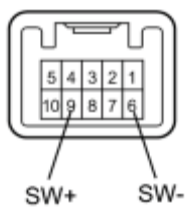

*1	Component without harness connected (Solar Ventilation Switch)
----	---

If the resistance is not as specified, replace the solar ventilation switch.

INSTALLATION

1. INSTALL SOLAR VENTILATION SWITCH

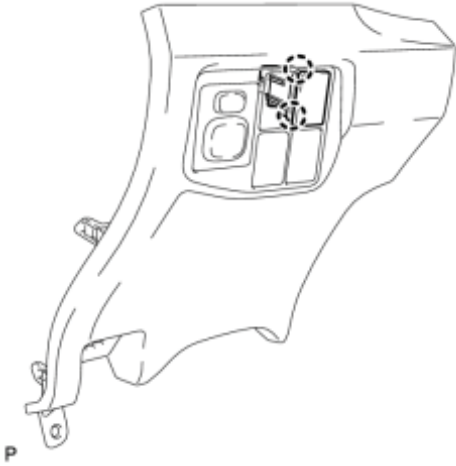

(a) Engage the 2 claws to install the solar ventilation switch.

2. INSTALL LOWER INSTRUMENT PANEL FINISH PANEL ASSEMBLY_ [INFO](#)

3. INSTALL COWL SIDE TRIM SUB-ASSEMBLY LH_ [INFO](#)

4. INSTALL FRONT DOOR SCUFF PLATE LH_ [INFO](#)

PRECAUTION

1. PRECAUTION FOR DISCONNECTING CABLE FROM NEGATIVE BATTERY TERMINAL

NOTICE:

When disconnecting the cable from the negative (-) battery terminal, initialize the following system after the terminal is reconnected.

System Name	See Procedure
Advanced Parking Guidance System	NFC

2. GENERAL PRECAUTION

(a) While using the battery during inspection, do not bring the positive (+) and negative (-) tester probes too close to each other as a short circuit may occur.

3. PRECAUTIONS WHEN USING TECHSTREAM

(a) When using the Techstream with the power switch off to troubleshoot:

Connect the Techstream to the vehicle, and turn a courtesy light switch on and off at 1.5-second intervals until communication between the Techstream and vehicle begins.

(b) After all DTCs are cleared, check if the trouble occurs again 6 seconds after the power switch is turned on (IG).

4. OPERATION PRECAUTIONS

(a) The solar ventilation system operates using electrical power generated by the moon roof glass assembly (solar panel). Therefore, the solar ventilation system stops operating when the amount of electricity generated by the moon roof glass assembly (solar panel) becomes insufficient.

HINT:

If the solar ventilation system stops operating due to the moon roof glass assembly (solar panel) generating an insufficient amount of electricity, the solar ventilation system will resume operating after output from the moon roof glass assembly (solar panel) has recovered.

(b) The solar ventilation system may degrade the air quality in the cabin or lower air conditioning efficiency depending on the usage environment. When ventilation is not necessary, turn the solar ventilation switch off.

- Depending on the usage environment, exhaust emissions from other vehicles or polluted outside air may enter in the cabin.
- Depending on the strength of the sunlight when the outside temperature is low, the cabin temperature may become low because of the cool air drawn into the cabin due to solar ventilation system operation.

- When the cabin temperature is initially low, the temperature may rise because the cool air escapes from the cabin due to solar ventilation system operation.

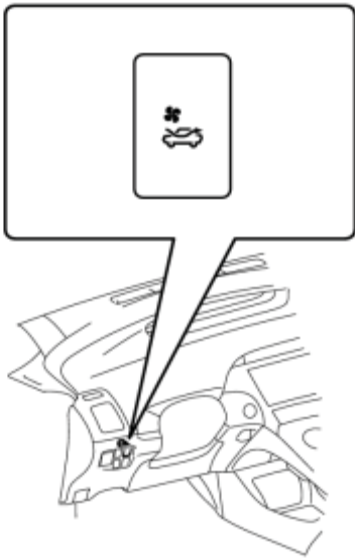

(c) If it is not necessary to operate the solar ventilation system while working on it, turn the solar ventilation switch off.

CAUTION:

Depending on the usage environment, performing repairs with the solar ventilation switch on may cause the blower motor to operate unexpectedly, resulting in various hazards. This can lead to damage to parts or a serious injury.

(d) Before disconnecting the moon roof glass assembly (solar panel) connector, make sure to cover the entire moon roof glass assembly (solar panel) with a material such as thick fabric which blocks sunlight.

CAUTION:

The moon roof glass assembly (solar panel) generates electricity from sunlight and other light sources. If the moon roof glass assembly (solar panel) connector is touched while the moon roof glass assembly (solar panel) is generating electricity, an accidental short circuit or electric shock may occur, causing serious injury.

HINT:

The moon roof glass assembly (solar panel) always generates electricity when exposed to light. When exposed to a light source such as sunlight, approximately 3.6 A and 22 V will be generated.

PARTS LOCATION

ILLUSTRATION

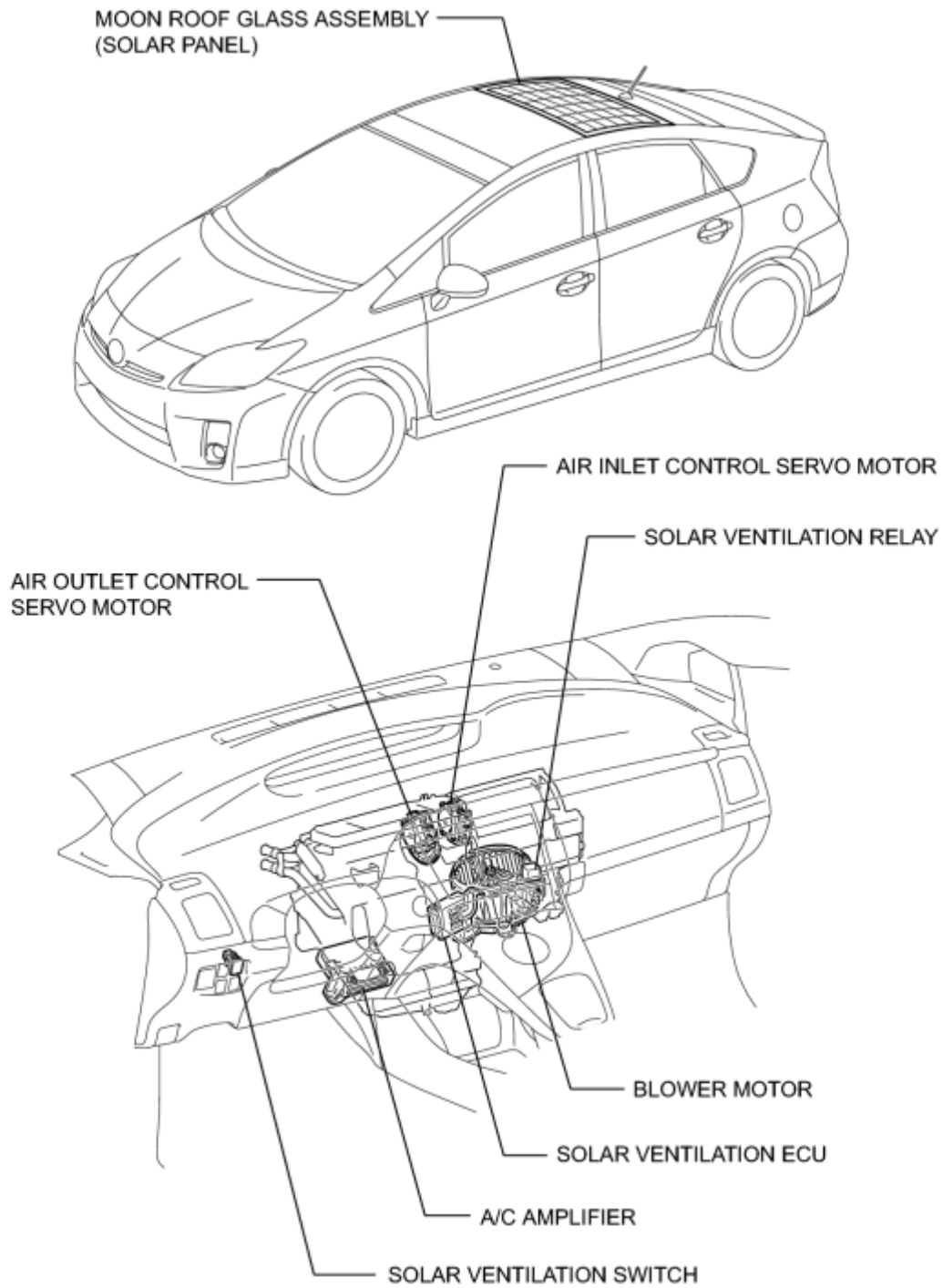

SYSTEM DIAGRAM

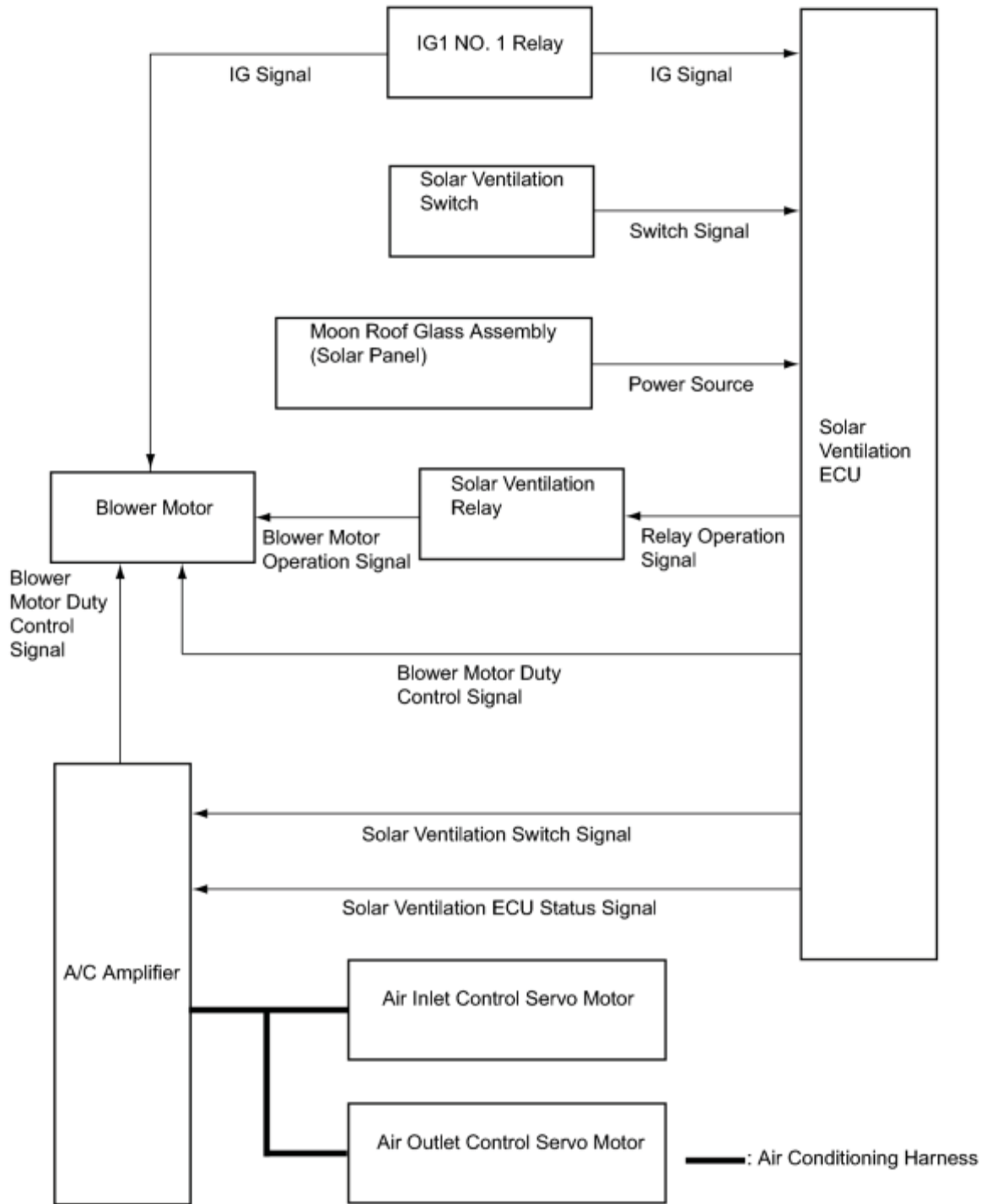

SYSTEM DESCRIPTION

1. GENERAL

(a) The solar ventilation system ventilates the cabin when the vehicle is parked in an extremely hot environment. Ventilation is provided by the system operating the blower motor using electricity generated by the moon roof glass assembly (solar panel) installed on the roof.

HINT:

- The solar ventilation system may operate even when not all conditions of the following table are met. Meeting all conditions of the following System Operation Condition Reference Table is necessary to obtain precise inspection results.

System Operation Conditions Reference Table

Item	Condition
Amount of sunlight	A sufficient amount of sunlight is received by the moon roof glass assembly (solar panel). (The amount of sunlight on a cloudless day between 11:00 and 14:00 is typically sufficient for operation.)
Moon roof glass assembly (solar panel) status	The moon roof glass assembly (solar panel) is not in the shade No fallen leaves or dirt is present on the moon roof glass assembly (solar panel)
Ambient temperature	20 to 40°C (68 to 104°F)

- Shortly after the solar ventilation system has been activated, it may stop the blower motor if the sunlight is not sufficient even when the rest of the system operation conditions reference table are met.

(b) Activation Control

(1) When the solar ventilation switch is turned on while the power switch is on (IG):

The inlets will be changed to fresh air mode and the outlets will be changed to face mode approximately 1 minute after the power switch is turned off. In addition, the blower motor will be activated and start ventilating the cabin approximately 10 minutes after the power switch is turned off.

HINT:

In order to enhance ventilation efficiency, the inlets will be changed to fresh air mode and the outlets will be changed to face mode automatically when the solar ventilation switch is turned on while the power switch is on (IG).

(2) When the solar ventilation switch is turned on after the power switch is turned off:

The blower motor will be activated and start ventilating the cabin approximately 10 minutes after the solar ventilation switch is turned on.

HINT:

Inlet and outlet modes will remain unchanged when the solar ventilation switch is turned on after the power switch is turned off.

(c) Stop Control

(1) When the solar ventilation switch is turned off or the power switch is turned on (IG), the solar ventilation system will stop operating.

HINT:

After the power switch is turned on (IG), both the inlets and outlets return to the mode that they were in before the power switch was turned off.

Example:

When the solar ventilation switch is turned on while the power switch is on (IG):

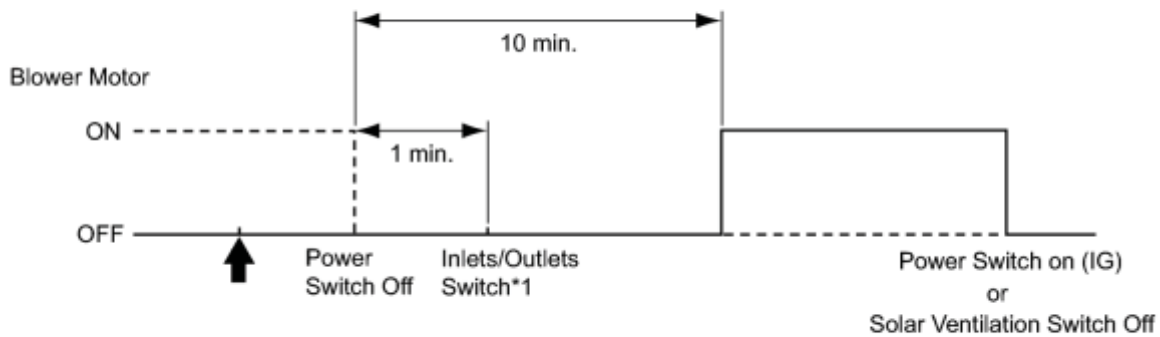

When the solar ventilation switch is turned on after the power switch is turned off:

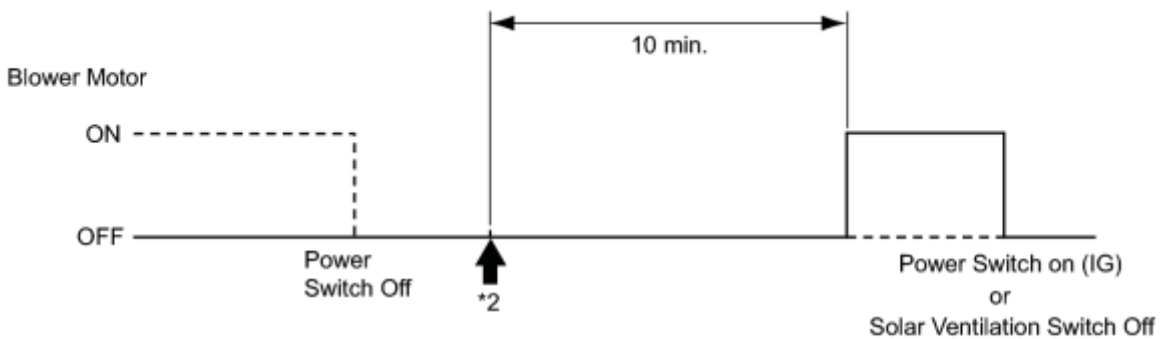

←: Solar Ventilation Switch On

*1: The inlets switch to fresh air mode and the outlets switch to face mode.

*2: The inlets and outlets do not switch.

2. FUNCTION OF MAIN COMPONENTS

(a) The solar ventilation system consists of the following components:

Component	Function
Moon roof glass assembly (solar panel)	Generates power from sunlight and supplies system power to the solar ventilation ECU.
Solar ventilation ECU	<ul style="list-style-type: none">• Activated by power generated by the moon roof glass assembly (solar panel).• Activates the solar ventilation system by receiving an on signal from the solar ventilation switch and an off signal from the vehicle power switch.• Sends a solar ventilation system condition signal to the A/C amplifier.• Operates the blower motor when the solar ventilation system is turned on.
Solar ventilation switch	Turns the solar ventilation system on or off.
Solar ventilation relay	Switches the power supply source for the blower motor between the auxiliary battery and solar ventilation ECU according to the power switch condition.
Blower motor	<ul style="list-style-type: none">• Performs ventilation when the power switch is off based on instructions from the solar ventilation ECU.• Changes its speed according to the amount of sunlight received by the moon roof glass assembly (solar panel).
A/C amplifier	<ul style="list-style-type: none">• Activates the air outlet control servo motor and air inlet control servo motor according to the signals from the solar ventilation ECU.• Receives solar ventilation system condition signal from the solar ventilation ECU and sends a solar ventilation system condition signal via CAN.
Air inlet control servo motor	Switches the inlets to fresh air mode based on signals from the A/C amplifier.
Air outlet control servo motor	Switches the outlets to face mode based on signals from the A/C amplifier.

HOW TO PROCEED WITH TROUBLESHOOTING

HINT:

- Use the following procedure to troubleshoot the solar ventilation system.
- *: Use the Techstream.

1. VEHICLE BROUGHT TO WORKSHOP

NEXT



2. INSPECT BATTERY VOLTAGE

(a) Inspect the battery voltage with the power switch off.

Standard Voltage:

11 to 14 V

If the voltage is below 11 V, recharge or replace the battery before proceeding to the next step.

NEXT



3. CHECK FOR DTC*

(a) Check for DTCs and note any code that is output.

(b) Clear the DTCs.

(c) Recheck for DTCs.

Result:

Result	Proceed to
DTC is not output.	A
DTC is output.	B

B ▶ GO TO RELEVANT SYSTEM

A



4. PROBLEM SYMPTOMS TABLE

(a) Refer to Problem Symptoms Table .

Result:

Result	Proceed to
Fault is not listed in Problem Symptoms Table	A

Result	Proceed to
Fault is listed in Problem Symptoms Table	B

B ▶ Go to step 5

A
▼

5.	OVERALL ANALYSIS AND TROUBLESHOOTING*
----	---------------------------------------

(a) Terminals of ECU INFO

(b) Data List / Active Test INFO

(c) Operation Check INFO

(d) Inspection

NEXT

▼

6.	ADJUST, REPAIR OR REPLACE
----	---------------------------

NEXT ▶ END

OPERATION CHECK

1. SOLAR VENTILATION SYSTEM OPERATION CHECK

(a) Inspection of Voltage Generated by Moon Roof Glass Assembly (Solar Panel)

(1) Park the vehicle in a location with a stable temperature and a sufficient amount of sunlight, and leave the vehicle as is for approximately 10 minutes.

NOTICE:

To ensure stable generation of voltage by the moon roof glass assembly (solar panel), make sure to park the vehicle in a location where the system operation conditions reference table are satisfied.

HINT:

The solar ventilation system operates only when the generated voltage is 10 V or higher. Therefore, make sure to park the vehicle where the system operation conditions reference table are satisfied. This will allow the moon roof glass assembly (solar panel) to generate a voltage of 10 V or higher.

System Operation Conditions Reference Table

Item	Condition
Amount of sunlight	A sufficient amount of sunlight is received by the moon roof glass assembly (solar panel). (The amount of sunlight on a cloudless day between 11:00 and 14:00 is typically sufficient for operation.)
Moon roof glass assembly (solar panel) status	The moon roof glass assembly (solar panel) is not in the shade No fallen leaves or dirt is present on the moon roof glass assembly (solar panel)
Ambient temperature	20 to 40°C (68 to 104°F)

(2) Connect the Techstream to the DLC3.

(3) Turn the power switch on (IG).

(4) Turn the Techstream on.

(5) Enter the following menus: Body Electrical / Air Conditioner / Data List.



Air Conditioner

Tester Display	Measurement Item/Range	Normal Condition	Diagnostic Note
Solar Voltage	Solar panel voltage / Variable, 10V les, 10V-11V, 11V-12V, 12V-13V, 13V-14V, 14V-15V, 15V-16V, 16V-17V, 17V-18V, 18V-19V, 19V-20V, 20V-21V, 21V-22V, 22V-23V or 23V	Actual generated voltage displayed	System operation conditions reference table are met  .

Tester Display	Measurement Item/Range	Normal Condition	Diagnostic Note
	ovr		

HINT:

If the Data List items related to the solar ventilation system are not displayed, the following conditions are suspected:

- The voltage generated by the moon roof glass assembly (solar panel) is less than 7 V .
- There is a communication error between the solar ventilation ECU and A/C amplifier .

(b) Operation Check

(1) Check that the Solar Voltage value in the Data List is 10 V or higher.

(2) Turn the solar ventilation switch on.

(3) Turn the power switch off.

(4) Check that the blower motor operates 10 minutes after the power switch is turned off.

HINT:

- The inlets will be changed to fresh air mode and the outlets will be changed to face mode approximately 1 minute after the power switch is turned off.
- Inlet and outlet modes will remain unchanged when the solar ventilation switch is turned on after the power switch is turned off.
- When the moon roof glass assembly (solar panel) is generating high voltage, a noise may occur when the blower motor starts operating. This noise does not indicate a malfunction.
- For details of the solar ventilation system control, refer to System Description .

2. TEST MODE

HINT:

In test mode, the solar ventilation ECU operates the blower motor while the power switch is on (IG). The state of the solar ventilation switch received by the solar ventilation ECU and the status of duty output from the solar ventilation ECU to the blower motor can be checked.

(a) Test Mode Procedure

HINT:

Perform the operation according to the following procedure with the power switch on (IG) and the solar ventilation switch off.

(1) Check that the Solar Voltage value in the Data List is 10 V or higher.

(2) With the power switch on (IG), turn the power switch from off to on (ACC) to on (IG) 3 times within 5 seconds (on (IG) → off → on (ACC) → on (IG) → off → on (ACC) → on (IG) → off → on (ACC) → on (IG)).

HINT:

Operate the power switch 9 times.

(3) Turn the solar ventilation switch from off to on 3 times within 3 seconds (off → on → off → on → off → on) of operating the power switch.

HINT:

Operate the solar ventilation switch 5 times.

(4) Check that test mode is activated and the blower motor rotates at a constant speed.

HINT:

- When the solar ventilation switch is turned off, the blower motor will stop and when the solar ventilation switch is turned on, the blower motor will operate.
- When the power switch is turned off, the solar ventilation system returns to normal control.

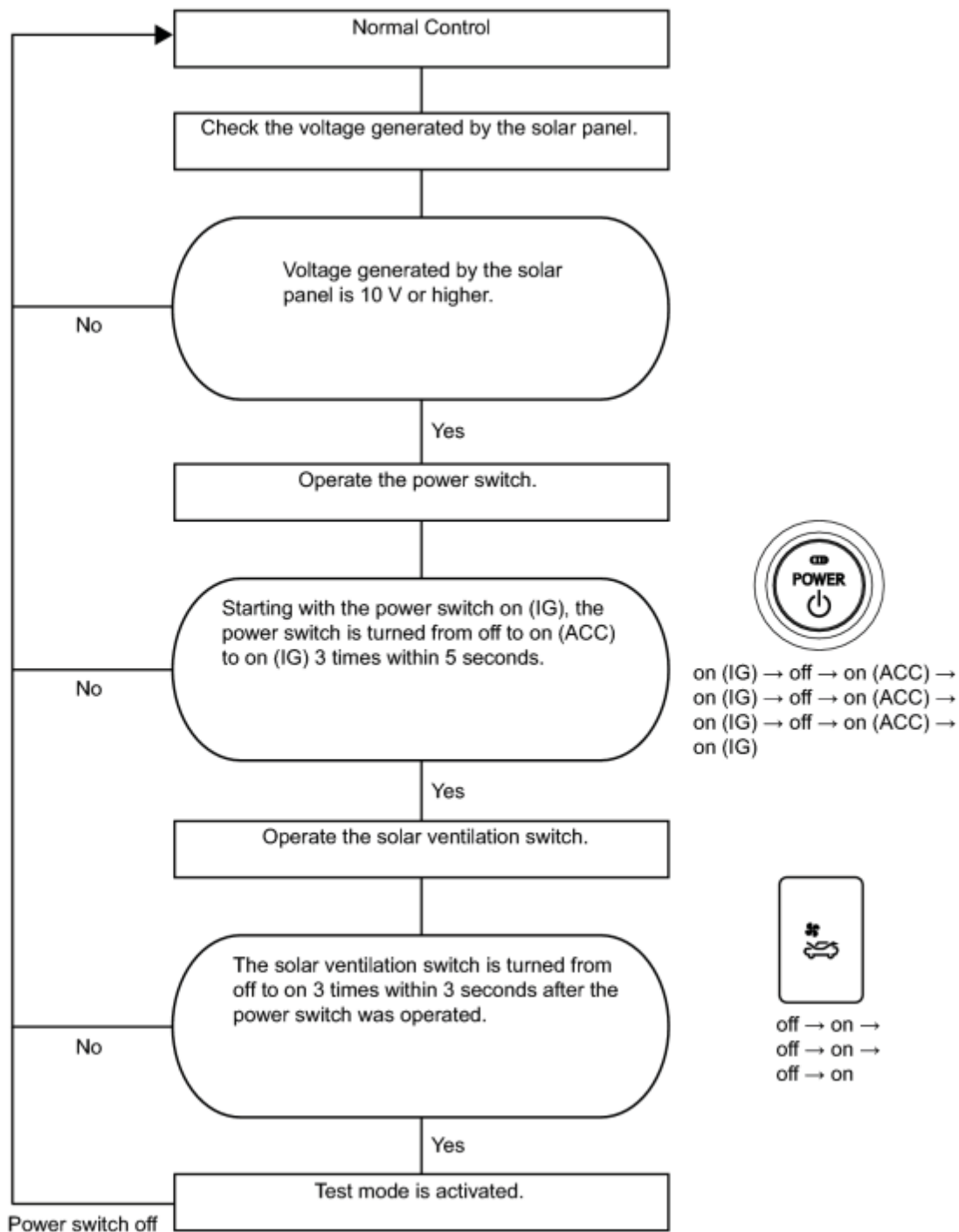

PROBLEM SYMPTOMS TABLE

HINT:

- Use the table below to help determine the cause of problem symptoms. If multiple suspected areas are listed, the potential causes of the symptoms are listed in order of probability in the "Suspected Area" column of the table. Check each symptom by checking the suspected areas in the order they are listed. Replace parts as necessary.
- Inspect the fuses and relays related to this system before inspecting the suspected areas below.

Solar Ventilation System

Symptom	Suspected Area	See page
Solar ventilation system does not operate.	Conditions listed in System Operation Conditions Reference Table have not been met	INFO
	Solar ventilation ECU power source circuit	INFO
	Solar ventilation switch circuit	INFO
	IG signal circuit	INFO
	Blower motor circuit	INFO
	Solar ventilation ECU	INFO
Solar ventilation system does not stop.	Solar ventilation switch circuit	INFO
	Blower motor circuit	INFO
	Solar ventilation ECU	INFO
Inlets do not change to fresh air mode.	Air conditioning system	INFO
	Solar ventilation switch circuit	INFO
	A/C amplifier	INFO
Outlets do not change to face mode.	Air conditioning system	INFO
	Solar ventilation switch circuit	INFO
	A/C amplifier	INFO
Blower motor operates but stops after a short while.	Conditions listed in System Operation Conditions Reference Table have not been met	INFO
	Solar ventilation ECU power source circuit	INFO
	Blower motor circuit	INFO
	Use simulation method to check	INFO
The blower motor operates by itself or the motor speed changes arbitrarily.	IG signal Circuit	INFO
	Solar ventilation ECU	INFO
Cabin is smelly or damp.	Conditions listed in System Operation Conditions Reference Table have not been met	INFO

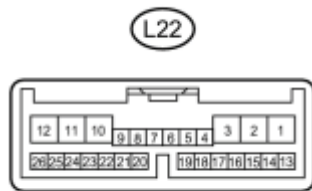

TERMINALS OF ECU

1. SOLAR VENTILATION ECU



HINT:

Check from the rear of the connector while it is connected to the solar ventilation ECU.

Terminal No. (Symbol)	Wiring Color	Terminal Description	Condition	Specified Condition
L22-1 (GND) - Body ground	W-B - Body ground	Ground	Always	Below 1 V
L22-5 (BLW) - L22-1 (GND)	V - W-B	Blower motor control signal	Power switch off Solar ventilation switch: on (blower motor operating)	Pulse generation (See waveform 1)
L22-11 (SBI) - L22-1 (GND)	G - W-B	Solar panel voltage	Always (System operation conditions reference table met )	1 to 28 V
L22-12 (BLWB) - L22-1 (GND)	R - W-B	Blower motor power source	Power switch off Solar ventilation switch: on (System operation conditions reference table met )	1 to 28 V
L22-13 (PVSW) - L22-1 (GND)	P - W-B	Solar ventilation switch signal	Solar ventilation switch: off Solar ventilation switch: on	4.5 to 5.5 V Below 1 V
L22-14 (PVSO) - L22-1 (GND)	P - W-B	Solar ventilation switch status signal	Solar ventilation switch: off Solar ventilation switch: on	4.5 to 5.5 V Below 1 V
L22-17 (SIND) - L22-1 (GND)	L - W-B	Solar ventilation ECU status signal	Power switch on (IG)	Pulse generation

Terminal No. (Symbol)	Wiring Color	Terminal Description	Condition	Specified Condition
			SBI terminal: 7 V or higher Solar ventilation system: off	(See waveform 2)
L22-25 (IG) - L22-1 (GND)	G - W-B	Power switch status signal	Power switch off	Below 1 V
			Power switch on (IG)	11 to 14 V

(a) Waveform 1:

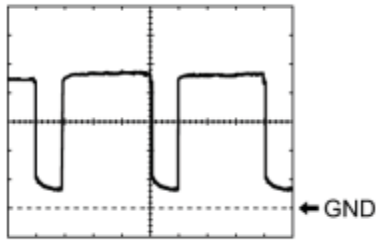

H

Item	Content
Terminal No.	L22-5 (BLW) - L22-1 (GND)
Tool Setting	1 V/DIV., 500 μs/DIV.
Vehicle Condition	Power switch off Solar ventilation switch: on (blower motor operating)

HINT:

The waveform varies with the blower speed.

(b) Waveform 2:

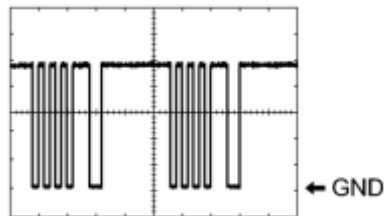

H

Item	Content
Terminal No.	L22-17 (SIND) - L22-1 (GND)
Tool Setting	1 V/DIV., 100 ms/DIV.
Vehicle Condition	Power switch on (IG) SBI terminal: 7 V or higher Solar ventilation system: off

HINT:

The waveform varies with the communication content.

2. A/C AMPLIFIER INFO

DATA LIST / ACTIVE TEST

1. DATA LIST

Using the Techstream to read the Data List allows the values or states of switches, sensors, actuators and other items to be read without removing any parts. This non-intrusive inspection can be very useful because intermittent conditions or signals may be discovered before parts or wiring is disturbed. Reading the Data List information early in troubleshooting is one way to save diagnostic time.

NOTICE:

In the table below, the values listed under "Normal Condition" are reference values. Do not depend solely on these reference values when deciding whether a part is faulty or not.

- (a) Connect the Techstream to the DLC3.
- (b) Turn the power switch on (IG).
- (c) Turn the Techstream on.
- (d) Enter the following menus: Body Electrical / Air Conditioner / Data List.
- (e) Check the value(s) by referring to the table below.



Air Conditioner

Tester Display	Measurement Item/Range	Normal Condition	Diagnostic Note
Solar Ventilation Switch	Solar ventilation switch (Switch recognition value at A/C amplifier side) / OFF or ON	OFF: Solar ventilation switch off ON: Solar ventilation switch on	-
Solar Voltage	Solar panel voltage / Variable, 10V les, 10V-11V, 11V-12V, 12V-13V, 13V-14V, 14V-15V, 15V-16V, 16V-17V, 17V-18V, 18V-19V, 19V-20V, 20V-21V, 21V-22V, 22V-23V or 23V ovr	Actual generated voltage displayed	System operation conditions reference table are met INFO .
Solar Ventilation Switch Status	Solar ventilation switch (Switch recognition value at solar ventilation ECU side) / OFF or ON	OFF: Solar ventilation switch off ON: Solar ventilation switch on	-
Solar IG Status	Solar ventilation ECU IG status /	OFF: Power	When OFF is displayed, a malfunction in the solar

Tester Display	Measurement Item/Range	Normal Condition	Diagnostic Note
	OFF or ON	switch off ON: Power switch on (IG)	ventilation ECU is suspected.
Solar Ventilation Test Mode Status	Solar ventilation ECU test mode status / OFF or ON	OFF: Test mode off ON: Test mode on	-

HINT:

If the Data List items related to the solar ventilation system are not displayed, the following conditions are suspected:

- The voltage generated by the moon roof glass assembly (solar panel) is less than 7 V .
- There is a communication error between the solar ventilation ECU and A/C amplifier .

2. ACTIVE TEST

Using the Techstream to perform Active Tests allows relays, VSVs, actuators and other items to be operated without removing any parts. This non-intrusive functional inspection can be very useful because intermittent operation may be discovered before parts or wiring is disturbed. Performing Active Tests early in troubleshooting is one way to save diagnostic time. Data List information can be displayed while performing Active Tests.

- Connect the Techstream to the DLC3.
- Turn the power switch on (IG).
- Turn the Techstream on.
- Enter the following menus: Body Electrical / Air Conditioner / Active Test.
- Check the operation by referring to the table below.

Air Conditioner

Tester Display	Test Part	Control Range	Diagnostic Note
Blower Motor	Blower motor	Min.: 0, Max.: 31	-

DESCRIPTION

The solar ventilation system activates when the vehicle power switch is off. If the solar ventilation switch has been turned on, the solar ventilation ECU checks that the vehicle power switch is off and then activates the solar ventilation system.

WIRING DIAGRAM

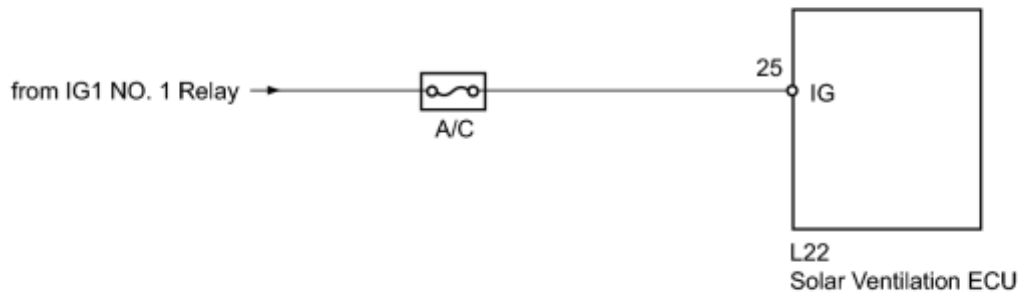

INSPECTION PROCEDURE

NOTICE:

Inspect the fuses for circuits related to this system before performing the following inspection procedure.

HINT:

Before performing this inspection procedure, check if the Data List items for the solar ventilation system are displayed. If the Data List items are not displayed, inspect the communication circuit between the solar ventilation ECU and A/C amplifier INFO.

PROCEDURE

1. READ VALUE USING TECHSTREAM

- (a) Connect the Techstream to the DLC3.
- (b) Turn the power switch on (IG).
- (c) Turn the Techstream on.

(d) Enter the following menus: Body Electrical / Air Conditioner / Data List.

(e) Check the value(s) by referring to the table below.

Air Conditioner

Tester Display	Measurement Item/Range	Normal Condition	Diagnostic Note
Solar IG Status	Solar ventilation ECU IG status / OFF or ON	OFF: Power switch off ON: Power switch on (IG)	When OFF is displayed, a malfunction in the solar ventilation ECU is suspected.

OK:

The display is as specified in the Normal Condition column.

Result:

Result	Proceed to
NG	A
OK (When troubleshooting according to Problem Symptoms Table (for Solar Ventilation System))	B
OK (When troubleshooting according to Problem Symptoms Table (for Air Conditioning System))	C

C ▶ PROCEED TO NEXT SUSPECTED AREA SHOWN IN PROBLEM SYMPTOMS TABLE

B ▶ PROCEED TO NEXT SUSPECTED AREA SHOWN IN PROBLEM SYMPTOMS TABLE

A



2.	CHECK HARNESS AND CONNECTOR (SOLAR VENTILATION ECU - BATTERY)
----	---

(a) Disconnect the solar ventilation ECU connector.

*1

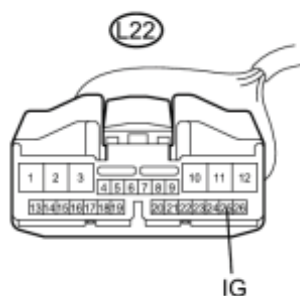

H

(b) Measure the voltage according to the value(s) in the table below.

Standard Voltage:

Tester Connection	Condition	Specified Condition
L22-25 (IG) - Body ground	Power switch off	Below 1 V
L22-25 (IG) - Body ground	Power switch on (IG)	11 to 14 V

Text in Illustration

*1	Front view of wire harness connector (to Solar Ventilation ECU)
----	--

NG ► REPAIR OR REPLACE HARNESS OR CONNECTOR

OK ► REPLACE SOLAR VENTILATION ECU

DESCRIPTION

The solar ventilation system and air conditioning system use the same blower motor for ventilation.

In order to be driven by each system, the blower motor switches between two different power sources using the solar ventilation relay. When the power switch is off, power from the solar ventilation system is supplied to the blower motor and when the power switch is in a mode other than off, power from the air conditioning system is supplied to the blower motor.

The blower motor controls its operation and speed using the power and signals supplied by the solar ventilation ECU when the power switch is off.

Changes its speed according to the amount of sunlight received by the moon roof glass assembly (solar panel).

WIRING DIAGRAM

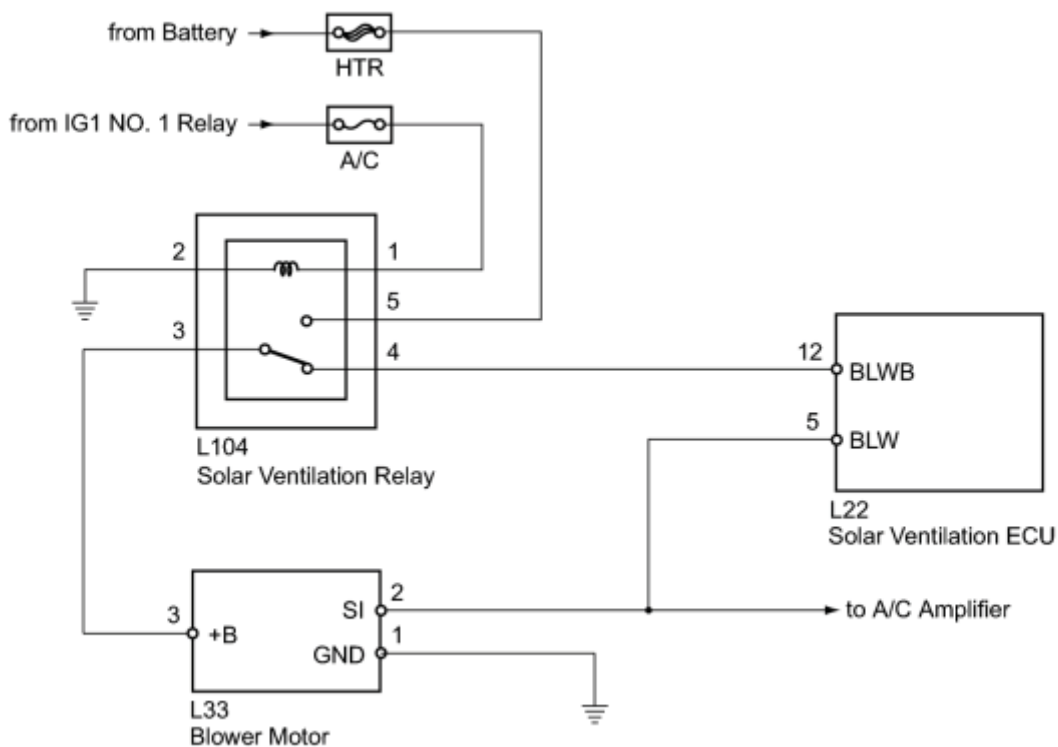

INSPECTION PROCEDURE

NOTICE:

Inspect the fuses for circuits related to this system before performing the following inspection procedure.

PROCEDURE

1. PERFORM ACTIVE TEST USING TECHSTREAM

- (a) Connect the Techstream to the DLC3.
- (b) Turn the power switch on (IG).
- (c) Turn the Techstream on.
- (d) Enter the following menus: Body Electrical / Air Conditioner / Active Test.
- (e) Check the operation by referring to the table below.

Air Conditioner

Tester Display	Test Part	Control Range	Diagnostic Note
Blower Motor	Blower motor	Min.: 0, Max.: 31	-

OK:

Blower motor operates and blower motor speed level changes.

NG ► GO TO AIR CONDITIONING SYSTEM (BLOWER MOTOR CIRCUIT)

OK



2. INSPECT SOLAR VENTILATION RELAY

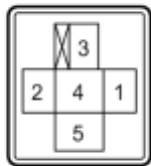
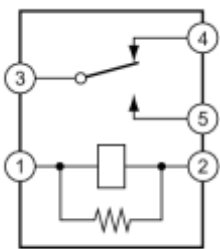

(a) Remove the solar ventilation relay.

H

(b) Measure the resistance according to the value(s) in the table below.

Standard Resistance:

Tester Connection	Specified Condition
3 - 5	10 k Ω or higher
3 - 4	Below 1 Ω

Tester Connection	Specified Condition
3 - 5	Below 1 Ω (when battery voltage is applied to terminals 1 and 2)
3 - 4	10 k Ω or higher (when battery voltage is applied to terminals 1 and 2)

NG  REPLACE SOLAR VENTILATION RELAY

OK



3.	INSPECT SOLAR VENTILATION ECU
----	-------------------------------

*1



(a) Disconnect the solar ventilation relay connector.

H

(b) Measure the voltage according to the value(s) in the table below.

Standard Voltage:

Tester Connection	Condition	Specified Condition
L104-4 - Body ground	Power switch off Solar ventilation switch off	Below 1 V
L104-4 - Body ground	Power switch off Solar ventilation switch on (System operation conditions reference table met )	1 to 28 V

Text in Illustration

*1	Front view of wire harness connector (to Solar Ventilation Relay)
----	--

NG [CHECK HARNESS AND CONNECTOR \(SOLAR VENTILATION ECU - SOLAR VENTILATION RELAY\)](#)

OK



4. CHECK HARNESS AND CONNECTOR (SOLAR VENTILATION ECU - BLOWER MOTOR)

*1

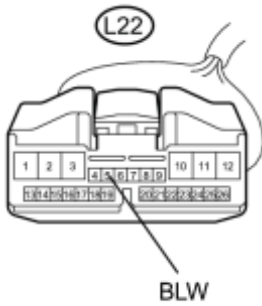

(a) Disconnect the solar ventilation ECU connector.

H

*2

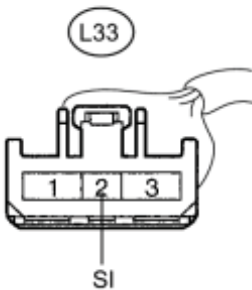

(b) Disconnect the blower motor connector.

(c) Measure the resistance according to the value(s) in the table below.

Standard Resistance:

Tester Connection	Condition	Specified Condition
L22-5 (BLW) - L33-2 (SI)	Always	Below 1 Ω
L22-5 (BLW) - Body ground	Always	10 k Ω or higher

Text in Illustration

*1	Front view of wire harness connector
----	--------------------------------------

	(to Solar Ventilation ECU)
*2	Front view of wire harness connector (to Blower Motor)

NG REPAIR OR REPLACE HARNESS OR CONNECTOR

OK



5.	INSPECT SOLAR VENTILATION ECU
----	-------------------------------

- (a) Reinstall the solar ventilation relay.
- (b) Reconnect the solar ventilation relay connector.
- (c) Reconnect the blower motor connector.
- (d) Reconnect the solar ventilation ECU connector.

(e) Measure the waveform between terminal L22-5 (BLW) of the solar ventilation ECU and body ground.

*1

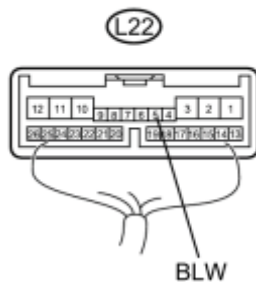

Item	Content
Tool setting	1 V/DIV., 500 μ s/DIV.
Vehicle condition	Power switch off Solar ventilation switch on (blower motor operating)

OK:

Waveform is as shown in the illustration.

HINT:

The waveform varies with the blower speed.

Text in Illustration

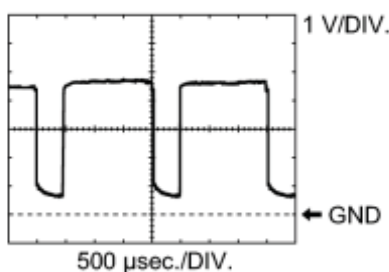

*1	Component with harness connected (Solar Ventilation ECU)
----	---

NG [REPLACE BLOWER MOTOR](#)

OK PROCEED TO NEXT SUSPECTED AREA SHOWN IN PROBLEM SYMPTOMS TABLE

6.	REPLACE BLOWER MOTOR
----	----------------------

(a) Replace the blower motor with a known good one and check if the same problem occurs again INFO.

OK:

Same problem does not occur.

NG ▶ REPLACE SOLAR VENTILATION ECU

OK ▶ END (BLOWER MOTOR WAS DEFECTIVE)

7.	CHECK HARNESS AND CONNECTOR (SOLAR VENTILATION ECU - SOLAR VENTILATION RELAY)
----	---

*1

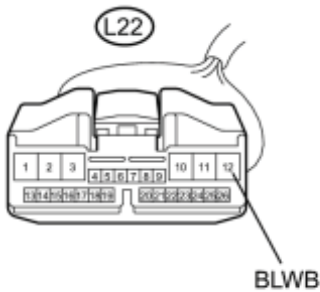

(a) Disconnect the solar ventilation ECU connector.

H

(b) Measure the resistance according to the value(s) in the table below.

Standard Resistance:

*2

Tester Connection	Condition	Specified Condition
L22-12 (BLWB) - L104-4	Always	Below 1 Ω
L22-12 (BLWB) - Body ground	Always	10 k Ω or higher



Text in Illustration

*1	Front view of wire harness connector (to Solar Ventilation ECU)
*2	Front view of wire harness connector (to Solar Ventilation Relay)

H

NG ▶ REPAIR OR REPLACE HARNESS OR CONNECTOR

OK ▶ REPLACE SOLAR VENTILATION ECU

DESCRIPTION

The solar ventilation system can operate when the solar ventilation switch is on and the moon roof glass assembly (solar panel) generates the necessary amount of electricity.

WIRING DIAGRAM

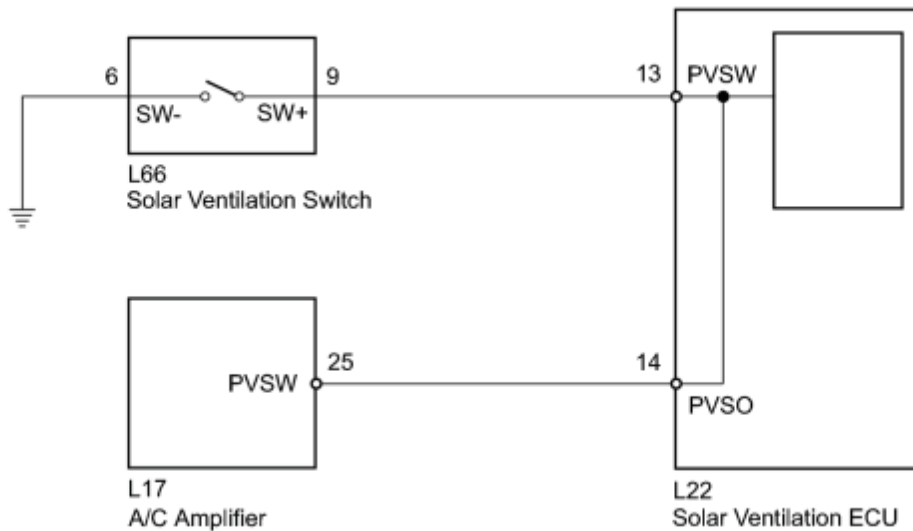

INSPECTION PROCEDURE

HINT:

Before performing this inspection procedure, check if the Data List items for the solar ventilation system are displayed. If the Data List items are not displayed, inspect the communication circuit between the solar ventilation ECU and A/C amplifier **NFC**.

PROCEDURE

1. READ VALUE USING TECHSTREAM

- (a) Connect the Techstream to the DLC3.
- (b) Turn the power switch on (IG).

(c) Turn the Techstream on.

(d) Enter the following menus: Body Electrical / Air Conditioner / Data List.

(e) Check the value(s) by referring to the table below.

Air Conditioner

Tester Display	Measurement Item/Range	Normal Condition	Diagnostic Note
Solar Ventilation Switch	Solar ventilation switch (Switch recognition value at A/C amplifier side) / OFF or ON	OFF: Solar ventilation switch off ON: Solar ventilation switch on	-
Solar Ventilation Switch Status	Solar ventilation switch (Switch recognition value at solar ventilation ECU side) / OFF or ON	OFF: Solar ventilation switch off ON: Solar ventilation switch on	-

OK:

The display is as specified in the Normal Condition column.

Result:

Result	Proceed to
OK	A
NG (OFF/ON display does not change for both Solar Ventilation Switch Status and Solar Ventilation Switch even though the solar ventilation switch is operated.)	B
NG (OFF/ON display does not change for Solar Ventilation Switch even though the solar ventilation switch is operated.)	C
NG (OFF/ON display does not change for Solar Ventilation Switch Status even though the solar ventilation switch is operated.)	D

D ▶ REPLACE SOLAR VENTILATION ECU

C ▶ CHECK HARNESS AND CONNECTOR (SOLAR VENTILATION ECU - A/C AMPLIFIER)

B ▶ INSPECT SOLAR VENTILATION SWITCH

A ▶ PROCEED TO NEXT SUSPECTED AREA SHOWN IN PROBLEM SYMPTOMS TABLE

2. INSPECT SOLAR VENTILATION SWITCH

*1



(a) Remove the solar ventilation switch.



(b) Measure the resistance according to the value(s) in the table below.

Standard Resistance:

Tester Connection	Condition	Specified Condition
L66-9 (SW+) - L66-6 (SW-)	Solar ventilation switch: off (when switch is not pressed)	10 k Ω or higher
L66-9 (SW+) - L66-6 (SW-)	Solar ventilation switch: on (when switch is pressed)	Below 1 Ω

Text in Illustration

*1	Component without harness connected (Solar Ventilation Switch)
----	---

NG REPLACE SOLAR VENTILATION SWITCH

OK



3. CHECK HARNESS AND CONNECTOR (SOLAR VENTILATION SWITCH - BODY GROUND)

(a) Measure the resistance according to the value(s) in the table below.

Standard Resistance:

*1

Tester Connection	Condition	Specified Condition
L66-6 (SW-) - Body ground	Always	Below 1 Ω

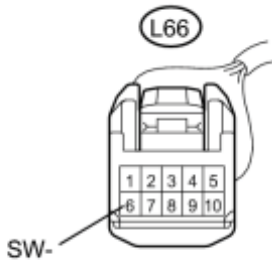

Text in Illustration

*1	Front view of wire harness connector (to Solar Ventilation Switch)
----	---

H

NG ► REPAIR OR REPLACE HARNESS OR CONNECTOR

OK



4.	CHECK HARNESS AND CONNECTOR (SOLAR VENTILATION SWITCH - SOLAR VENTILATION ECU)
----	--

*1

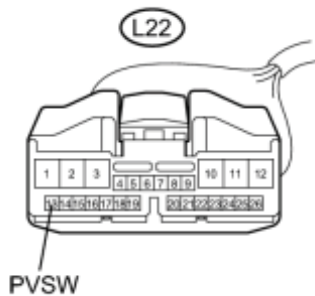

H

(a) Disconnect the solar ventilation ECU connector.

(b) Measure the resistance according to the value(s) in the table below.

Standard Resistance:

Tester Connection	Condition	Specified Condition
L22-13 (PVSU) - L66-9 (SW+)	Always	Below 1 Ω
L22-13 (PVSU) - Body ground	Always	10 kΩ or higher

Text in Illustration

*2



*1	Front view of wire harness connector (to Solar Ventilation ECU)
*2	Front view of wire harness connector (to Solar Ventilation Switch)

H

NG ► REPAIR OR REPLACE HARNESS OR CONNECTOR

OK ► REPLACE SOLAR VENTILATION ECU

5. CHECK HARNESS AND CONNECTOR (SOLAR VENTILATION ECU - A/C AMPLIFIER)

*1

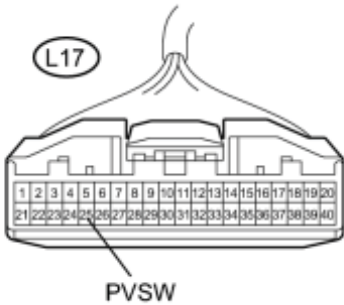

(a) Disconnect the A/C amplifier connector.

H

(b) Measure the resistance according to the value(s) in the table below.

*2

Standard Resistance:

Tester Connection	Condition	Specified Condition
L17-25 (PVSW) - L22-14 (PVSO)	Always	Below 1 Ω
L17-25 (PVSW) - Body ground	Always	10 kΩ or higher

Text in Illustration

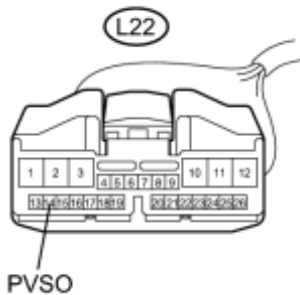

H

*1	Front view of wire harness connector (to A/C Amplifier)
----	--

*2

Front view of wire harness connector
(to Solar Ventilation ECU)

NG ► REPAIR OR REPLACE HARNESS OR CONNECTOR

OK



6. REPLACE SOLAR VENTILATION ECU

(a) Replace the solar ventilation ECU with a known good one and check if the same problem occurs again 

.

OK:

Same problem does not occur.

NG ► REPLACE A/C AMPLIFIER

OK ► **END (SOLAR VENTILATION ECU WAS DEFECTIVE)**

DESCRIPTION

For the solar ventilation system, the moon roof glass assembly (solar panel) generates electricity using sunlight to generate the required power.

The electricity generated by the moon roof glass assembly (solar panel) is sent to the solar ventilation ECU and used as the power source for the solar ventilation system.

WIRING DIAGRAM

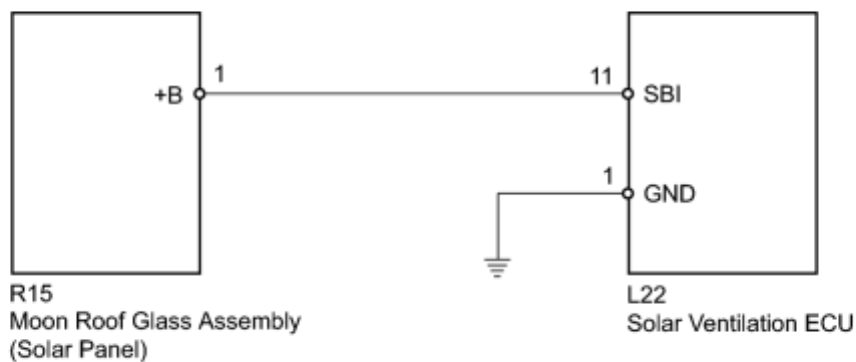

INSPECTION PROCEDURE

PROCEDURE

1. INSPECT MOON ROOF GLASS ASSEMBLY (SOLAR PANEL)

(a) Leave the vehicle for 10 minutes in a location where the following conditions are met, and then measure the voltage.

System Operation Conditions Reference Table

Items	Condition
Amount of sunlight	A sufficient amount of sunlight is received by the moon roof glass assembly (solar panel). (The amount of sunlight on a cloudless day between 11:00 and 14:00 is typically sufficient for operation.)
Moon roof glass assembly (solar panel) status	The moon roof glass assembly (solar panel) is not in the shade No fallen leaves or dirt is present on the moon roof glass assembly (solar

Items	Condition
	panel)
Ambient temperature	20 to 40°C (68 to 104°F)

NOTICE:

To ensure stable generation of voltage by the moon roof glass assembly (solar panel), make sure to park the vehicle in a location where the system operation conditions reference table are satisfied.

*1

(b) Disconnect the solar ventilation ECU connector.

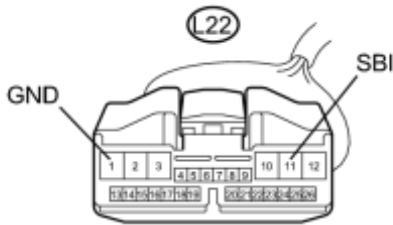

CAUTION:

The moon roof glass assembly (solar panel) generates electricity when exposed to a light source such as sunlight. If an inspection of the moon roof glass assembly (solar panel) is performed while electricity is being generated, work carefully in order to prevent an accidental short circuit or electric shock.

H

(c) Measure the voltage according to the value(s) in the table below.

Standard Voltage:

Tester Connection	Condition	Specified Condition
L22-11 (SBI) - L22-1 (GND)	System operation conditions reference table are met.	12 V or higher

Text in Illustration

*1	Front view of wire harness connector (to Solar Ventilation ECU)
----	--

NG [CHECK HARNESS AND CONNECTOR \(SOLAR VENTILATION ECU - SOLAR PANEL, BODY GROUND\)](#)

OK



2.	READ VALUE USING TECHSTREAM
----	-----------------------------

(a) Reconnect the solar ventilation ECU connector.

(b) Connect the Techstream to the DLC3.

- (c) Turn the power switch on (IG).
- (d) Turn the Techstream on.
- (e) Enter the following menus: Body Electrical / Air Conditioner / Data List.
- (f) Check the value(s) by referring to the table below.
- (1) Check that the Solar Voltage value in the Data List is 10 V or higher.

Air Conditioner

Tester Display	Measurement Item/Range	Normal Condition	Diagnostic Note
Solar Voltage	Solar panel voltage / Variable, 10V les, 10V-11V, 11V-12V, 12V-13V, 13V-14V, 14V-15V, 15V-16V, 16V-17V, 17V-18V, 18V-19V, 19V-20V, 20V-21V, 21V-22V, 22V-23V or 23V ovr	Actual generated voltage displayed	System operation conditions reference table are met INFO .

OK:
10 V or higher

HINT:

If the Data List items are not displayed, inspect the communication circuit between the solar ventilation ECU and A/C amplifier INFO.

NG ▶ REPLACE SOLAR VENTILATION ECU

OK ▶ PROCEED TO NEXT SUSPECTED AREA SHOWN IN PROBLEM SYMPTOMS TABLE

3.	CHECK HARNESS AND CONNECTOR (SOLAR VENTILATION ECU - SOLAR PANEL, BODY GROUND)
----	--

*1

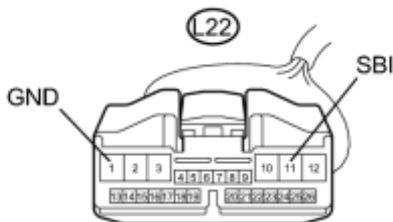

(a) Disconnect the solar ventilation ECU connector.

H



(b) Disconnect the moon roof glass assembly (solar panel) connector.

H

(c) Measure the resistance according to the value(s) in the table below.

Standard Resistance:

Tester Connection	Condition	Specified Condition
L22-11 (SBI) - R15-1 (+B)	Always	Below 1 Ω
L22-1 (GND) - Body ground	Always	Below 1 Ω
L22-11 (SBI) - Body ground	Always	10 k Ω or higher

Text in Illustration

*1	Front view of wire harness connector (to Solar Ventilation ECU)
*2	Front view of wire harness connector (to Moon Roof Glass Assembly (Solar Panel))

NG ► REPAIR OR REPLACE HARNESS OR CONNECTOR

OK ► REPLACE MOON ROOF GLASS ASSEMBLY (SOLAR PANEL)

DESCRIPTION

The solar ventilation ECU communicates with the A/C amplifier using a direct line. The A/C amplifier checks the condition of the solar ventilation system based on signals sent via the direct line.

When this circuit malfunctions, Data List items for the solar ventilation system will not be displayed.

WIRING DIAGRAM

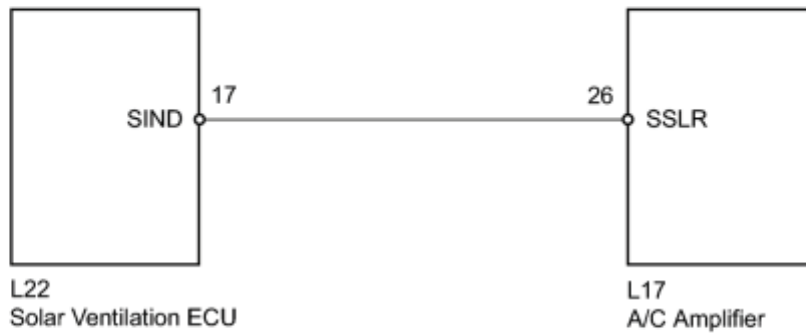

INSPECTION PROCEDURE

PROCEDURE

1. CHECK HARNESS AND CONNECTOR (SOLAR VENTILATION ECU - A/C AMPLIFIER)

*1

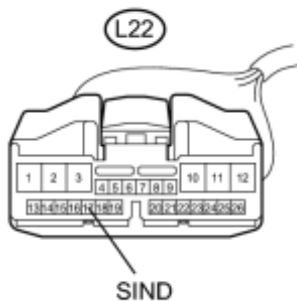

- (a) Disconnect the solar ventilation ECU connector.

H

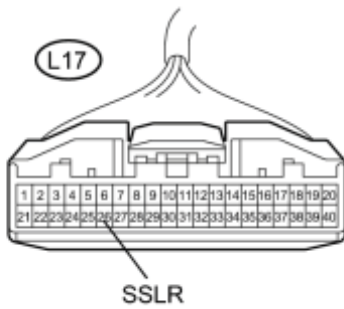

(b) Disconnect the A/C amplifier connector.

(c) Measure the resistance according to the value(s) in the table below.

Standard Resistance:

Tester Connection	Condition	Specified Condition
L22-17 (SIND) - L17-26 (SSLR)	Always	Below 1 Ω
L22-17 (SIND) - Body ground	Always	10 k Ω or higher

Text in Illustration

*1	Front view of wire harness connector (to Solar Ventilation ECU)
*2	Front view of wire harness connector (to A/C Amplifier)

NG ► REPAIR OR REPLACE HARNESS OR CONNECTOR

OK



2. REPLACE SOLAR VENTILATION ECU

(a) Replace the solar ventilation ECU with a known good one and check if the same problem occurs again INFO

OK:

Same problem does not occur.

NG ► REPLACE A/C AMPLIFIER

OK  **END (SOLAR VENTILATION ECU WAS DEFECTIVE)**