

DTC	C1246/46	MALFUNCTION IN MASTER CYLINDER PRESSURE SENSOR
------------	-----------------	---

DTC	C1364/61	MALFUNCTION IN W/C PRESSURE SENSOR
------------	-----------------	---

CIRCUIT DESCRIPTION

The master cylinder pressure sensor and the wheel cylinder pressure sensor are built into the brake actuator, and measure the master cylinder pressure and the wheel cylinder pressure send to the skid control ECU.

DTC No.	Detailed Code	DTC Detecting Condition	Trouble Area
C1246/46	191	Sensor power source 1 (VMC1) voltage is less than 4.7 V or 5.3 V or more for at least 0.05 sec.	<ul style="list-style-type: none"> • Brake actuator assy • Skid control ECU • Harness and connector
C1246/46	192	Ratio of master pressure sensor output voltage 1 (PMC1) to sensor power source (VMC1) is less than 5% or 90.5% or more for at least 0.05 sec.	<ul style="list-style-type: none"> • Brake actuator assy • Skid control ECU • Harness and connector
C1246/46	194	Sensor power source 2 (VMC2) voltage is less than 4.7 V or 5.3 V or more for at least 0.05 sec.	<ul style="list-style-type: none"> • Brake actuator assy • Skid control ECU • Harness and connector
C1246/46	195	Ratio of master pressure sensor output voltage 2 (PMC2) to sensor power source (VMC2) is less than 5% or 90.5% or more for at least 0.05 sec.	<ul style="list-style-type: none"> • Brake actuator assy • Skid control ECU • Harness and connector
C1246/46	197	Master pressure sensor output voltage 1 (PMC1) is abnormal.	<ul style="list-style-type: none"> • Brake actuator assy • Skid control ECU
C1246/46	198	Master pressure sensor output voltage 2 (PMC2) is abnormal.	<ul style="list-style-type: none"> • Brake actuator assy • Skid control ECU
C1246/46	199	Master pressure sensor output 1 (PMC1) is not approx. 0 Mpa when not braking.	<ul style="list-style-type: none"> • Brake actuator assy • Skid control ECU • Harness and connector • Stop input signal
C1246/46	200	Master pressure sensor output 2 (PMC2) is not approx. 0 Mpa when not braking.	<ul style="list-style-type: none"> • Brake actuator assy • Skid control ECU • Harness and connector • Stop input signal
C1246/46	201	PMC1 and PMC2 voltages are different when braking.	<ul style="list-style-type: none"> • Brake actuator assy • Skid control ECU • Harness and connector
C1246/46	202	Master pressure sensor 1 data (PMC1) is invalid.	<ul style="list-style-type: none"> • Brake actuator assy • Skid control ECU • Harness and connector
C1246/46	205	Master pressure sensor 2 data (PMC2) is invalid.	<ul style="list-style-type: none"> • Brake actuator assy • Skid control ECU • Harness and connector
C1364/61	221	Sensor power source 1 (VMC1) voltage is less than 4.7 V or 5.3 V or more for at least 0.05 sec.	<ul style="list-style-type: none"> • Harness and connector • Skid control ECU
C1364/61	222	Ratio of FR right sensor output voltage (PFR) to sensor power source (VCM1) is less than 5% or 90.5% or more for at least 0.05 sec.	<ul style="list-style-type: none"> • Brake actuator assy • Skid control ECU • Harness and connector

DTC No.	Detailed Code	DTC Detecting Condition	Trouble Area
C1364/61	224	<ul style="list-style-type: none"> FR right sensor output (PFR) is not approx. 0 Mpa when not braking. FR right sensor (PFR) zero point malfunction. Open or short in FR right sensor (PFR) circuit. 	<ul style="list-style-type: none"> Brake actuator assy Skid control ECU Harness and connector
C1364/61	225	Ratio of FR right sensor output voltage (PFR) to sensor power source (VCM1) is less than 90.5% for at least 0.1 sec. when self-diagnosis signal is output.	<ul style="list-style-type: none"> Brake actuator assy Skid control ECU Harness and connector
C1364/61	227	Sensor power source 2 (VMC2) voltage is less than 4.7 V or 5.3 V or more for at least 0.05 sec.	<ul style="list-style-type: none"> Brake actuator assy Skid control ECU Harness and connector
C1364/61	228	Ratio of FR left sensor output voltage (PFL) to sensor power source (VCM2) is less than 5% or 90.5% or more for at least 0.05 sec.	<ul style="list-style-type: none"> Brake actuator assy Skid control ECU Harness and connector
C1364/61	230	<ul style="list-style-type: none"> FR left sensor (PFL) is not approx. 0 Mpa when not braking. FR left sensor (PFL) zero point malfunction Open or short in FR right sensor (PFL) circuit. 	<ul style="list-style-type: none"> Brake actuator assy Skid control ECU Harness and connector
C1364/61	231	Ratio of FR left sensor output voltage (PFL) to sensor power source (VCM2) is less than 90.5% for at least 0.1 sec. when self-diagnosis signal is output.	<ul style="list-style-type: none"> Brake actuator assy Skid control ECU Harness and connector
C1364/61	233	Sensor power source 2 (VCM2) voltage is less than 4.7 V or 5.3 V or more for at least 0.05 sec.	<ul style="list-style-type: none"> Brake actuator assy Skid control ECU Harness and connector
C1364/61	234	Ratio of RR right sensor output voltage (PRR) to sensor power source (VCM2) is less than 5% or 90.5% or more for at least 0.05 sec.	<ul style="list-style-type: none"> Brake actuator assy Skid control ECU Harness and connector
C1364/61	236	<ul style="list-style-type: none"> RR right sensor output voltage (PRR) is not approx. 0 Mpa when not braking. RR right sensor (PRR) zero point malfunction. Open or short in RR sensor (PRR) circuit. 	<ul style="list-style-type: none"> Brake actuator assy Skid control ECU Harness and connector
C1364/61	237	Ratio of RR right sensor output voltage (PRR) to sensor power source (VCM2) is less than 90.5% for at least 0.1 sec. when self-diagnosis signal is output.	<ul style="list-style-type: none"> Brake actuator assy Skid control ECU Harness and connector
C1364/61	239	Sensor power source (VMC1) voltage is less than 4.7 V or 5.3 V or more for at least 0.05 sec.	<ul style="list-style-type: none"> Brake actuator assy Skid control ECU Harness and connector
C1364/61	240	Ratio of RR left sensor output voltage (PRL) to sensor power source (VCM1) is less than 5% or 90.5% or more for at least 0.05 sec.	<ul style="list-style-type: none"> Brake actuator assy Skid control ECU Harness and connector

DIAGNOSTICS – ELECTRONICALLY CONTROLLED BRAKE SYSTEM

DTC No.	Detailed Code	DTC Detecting Condition	Trouble Area
C1364/61	226	Voltage difference before and after changing the pull-up resistance in the sensor signal input circuit is 0.3 V or more (poor connection).	<ul style="list-style-type: none"> • Brake actuator assy • Skid control ECU • Harness and connector
C1364/61	232	Voltage difference before and after changing the pull-up resistance in the sensor signal input circuit is 0.3 V or more (poor connection).	<ul style="list-style-type: none"> • Brake actuator assy • Skid control ECU • Harness and connector
C1364/61	238	Voltage difference before and after changing the pull-up resistance in the sensor signal input circuit is 0.3 V or more (poor connection).	<ul style="list-style-type: none"> • Brake actuator assy • Skid control ECU • Harness and connector
C1364/61	242	<ul style="list-style-type: none"> • RR left sensor output (PRL) is not approx. 0 Mpa when not braking. • RR left sensor (PRL) zero point malfunction. • Open or short in RR left sensor (PRL) circuit. 	<ul style="list-style-type: none"> • Brake actuator assy • Skid control ECU • Harness and connector
C1364/61	243	• Ratio of RR left sensor output voltage (PRL) to sensor power source (VCM1) is less than 90.5% for at least 0.1 sec. when sel-diagnosis signal is output.	<ul style="list-style-type: none"> • Brake actuator assy • Skid control ECU • Harness and connector
C1364/61	244	Voltage difference before and after changing the pull-up resistance in the sensor signal input circuit is 0.3 V or more (poor connection).	<ul style="list-style-type: none"> • Brake actuator assy • Skid control ECU • Harness and connector

WIRING DIAGRAM

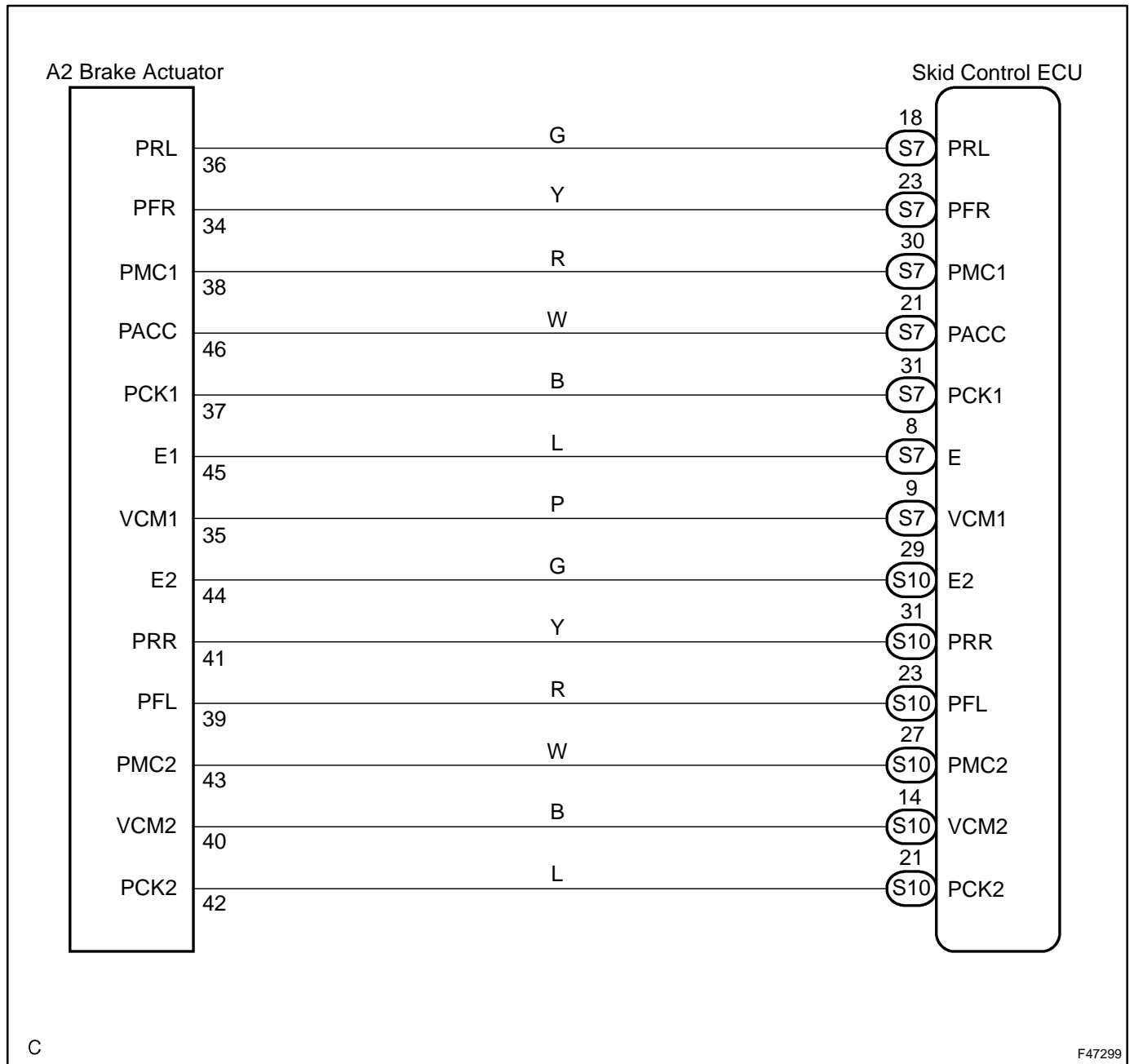

INSPECTION PROCEDURE

1 CHECK HARNESS AND CONNECTOR

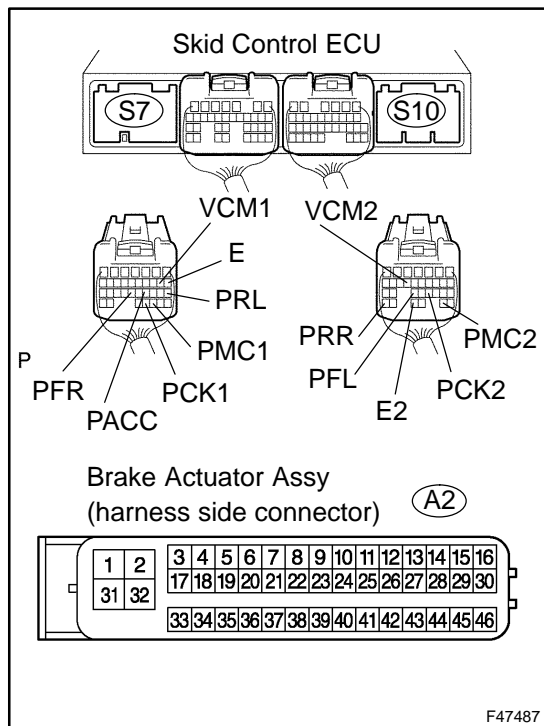

- (a) Disconnect the skid control ECU connector and brake actuator connector.
- (b) Measure the resistance according to the value(s) in the table below.

Standard:

Tester Connection	Specified Condition
S7-8 (E) - A2-45 (E1)	Below 1 Ω
S7-9 (VCM1) - A2-35 (VCM1)	Below 1 Ω
S7-18 (PRL) - A2-36 (PRL)	Below 1 Ω
S7-21 (PACC) - A2-46 (PACC)	Below 1 Ω
S7-23 (PFR) - A2-34 (PFR)	Below 1 Ω
S7-30 (PMC1) - A2-38 (PMC1)	Below 1 Ω
S7-31 (PCK1) - A2-37 (PCK1)	Below 1 Ω
S10-14 (VCM2) - A2-40 (VCM2)	Below 1 Ω
S10-21 (PCK2) - A2-42 (PCK2)	Below 1 Ω
S10-23 (PFL) - A2-39 (PFL)	Below 1 Ω
S10-27 (PMC2) - A2-43 (PMC2)	Below 1 Ω
S10-29 (E2) - A2-44 (E2)	Below 1 Ω
S10-31 (PRR) - A2-41 (PRR)	Below 1 Ω

- (c) Measure the resistance according to the value(s) in the table below.

Standard:

Tester Connection	Specified Condition
S7-8 (E) - Body ground	10 k Ω or higher
S7-9 (VCM1) - Body ground	10 k Ω or higher
S7-18 (PRL) - Body ground	10 k Ω or higher
S7-21 (PACC) - Body ground	10 k Ω or higher
S7-23 (PFR) - Body ground	10 k Ω or higher
S7-30 (PMC1) - Body ground	10 k Ω or higher
S7-31 (PCK1) - Body ground	10 k Ω or higher
S10-14 (VCM2) - Body ground	10 k Ω or higher
S10-21 (PCK2) - Body ground	10 k Ω or higher
S10-27 (PMC2) - Body ground	10 k Ω or higher
S10-29 (E2) - Body ground	10 k Ω or higher
S10-31 (PRR) - Body ground	10 k Ω or higher

NG

REPAIR OR REPLACE HARNESS OR CONNECTOR

OK

2 INSPECT SKID CONTROL ECU TERMINAL VOLTAGE

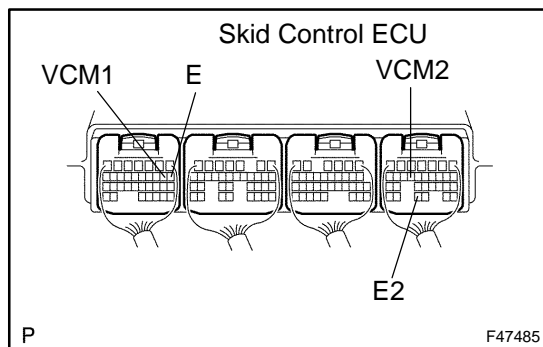

(a) Measure the voltage according to the value(s) in the table below.

HINT:

Measure the voltage from behind the connector with the connector connected to the skid control ECU.

Standard:

Tester Connection	Condition	Specified Condition
S7-9 (VCM1) – Body ground	Power switch ON (READY)	4.75 to 5.25 V
S10-14 (VCM2) – Body ground	Power switch ON (READY)	4.75 to 5.25 V

(b) Measure the resistance according to the value(s) in the table below.

Standard:

Tester Connection	Specified Condition
S7-8 (E) – Body ground	Below 1 Ω
S10-29 (E2) – Body ground	Below 1 Ω

NG → **REPLACE SKID CONTROL ECU ASSY (SEE PAGE 32-68)**

OK

3 READ VALUE OF HAND-HELD TESTER

- (a) Connect the hand-held tester to the DLC3.
- (b) Select the DATA LIST mode on the hand-held tester.

Item	Measurement Item / Range (Display)	Normal Condition
MAS CYL PRS 1	Master cylinder pressure sensor 1 reading / min.: 0 V, max.: 5 V	When brake pedal is released: 0.3 to 0.9 V
MAS CYL PRS 2	Master cylinder pressure sensor 2 reading / min.: 0 V, max.: 5 V	When brake pedal is released: 0.3 to 0.9 V

(c) Check the output value of the master cylinder pressure sensor on the hand-held tester display.

OK:

When the pedal is depressed, displayed voltage on the hand-held tester increase.

NG → **REPLACE BRAKE ACTUATOR ASSY (SEE PAGE 32-54)**

OK

4	READ VALUE OF HAND-HELD TESTER
----------	---------------------------------------

- (a) Connect the pedal effort gauge.
 (b) Install the LSPV gauge (SST) and bleed air (see page 32-4).
 SST 09709-29018
 (c) Connect the hand-held tester to the DLC3.
 (d) Select the DATA LIST mode on the hand-held tester.

Item	Measurement Item / Range (Display)	Normal Condition
FR PRESS SENS	Front Right pressure sensor / min.: 0 V, max.: 5 V	When brake pedal is released: 0.3 to 0.9 V
FL PRESS SENS	Front Left pressure sensor / min.: 0 V, max.: 5 V	When brake pedal is released: 0.3 to 0.9 V
RR PRESS SENS	Rear Right pressure sensor / min.: 0 V, max.: 5 V	When brake pedal is released: 0.3 to 0.9 V
RL PRESS SENS	Rear Left pressure sensor / min.: 0 V, max.: 5 V	When brake pedal is released: 0.3 to 0.9 V

- (e) Check the output value of the wheel cylinder pressure sensor at each fluid pressure during the ECB control.

Standard:

Fluid Pressure MPa (kgf/cm ² , psi)	FR PRESS SENS (DATA-LIST)	FL PRESS SENS (DATA-LIST)	RR PRESS SENS (DATA-LIST)	RL PRESS SENS (DATA-LIST)
1 (10.2, 145.0)	0.65 to 0.75 V	0.65 to 0.75 V	0.65 to 0.75 V	0.65 to 0.75 V
3 (30.6, 435.2)	1.05 to 1.2 V	1.05 to 1.2 V	1.05 to 1.2 V	1.05 to 1.2 V
7 (71.4, 1015.5)	1.8 to 2.05 V	1.8 to 2.05 V	-	-
10 (102.0, 1450.7)	2.4 to 2.7 V	2.4 to 2.7 V	-	-

NG

REPLACE BRAKE ACTUATOR ASSY (SEE PAGE 32-54)

OK

REPLACE SKID CONTROL ECU ASSY (SEE PAGE 32-68)

NOTICE:

When replacing the skid control ECU assy, perform initialization of linear solenoid valve and calibration (see page 05-958).