

ILLUSTRATION

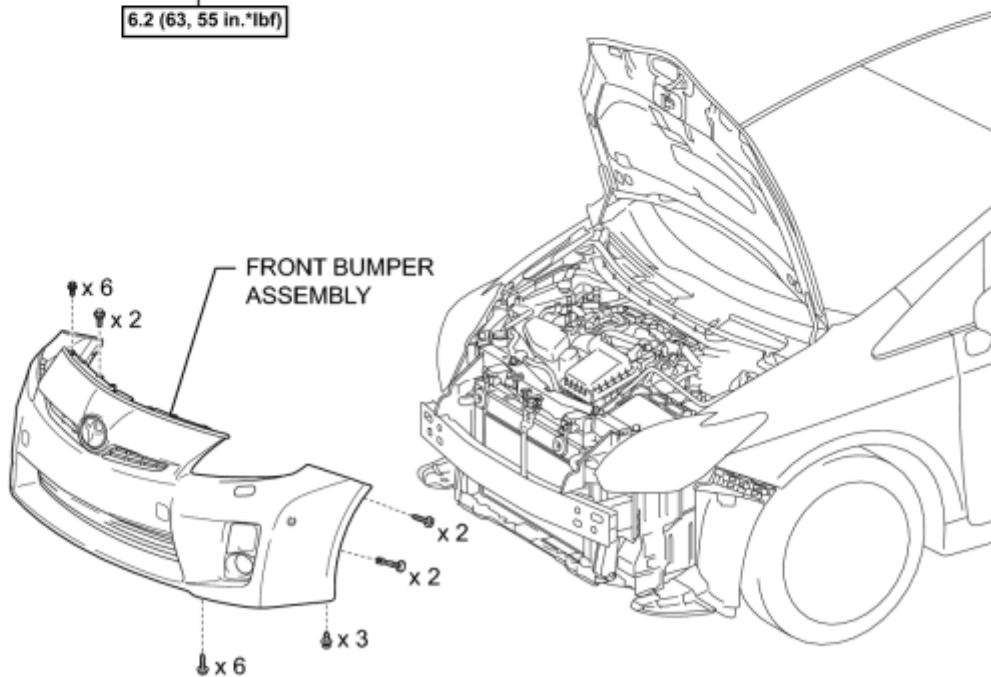
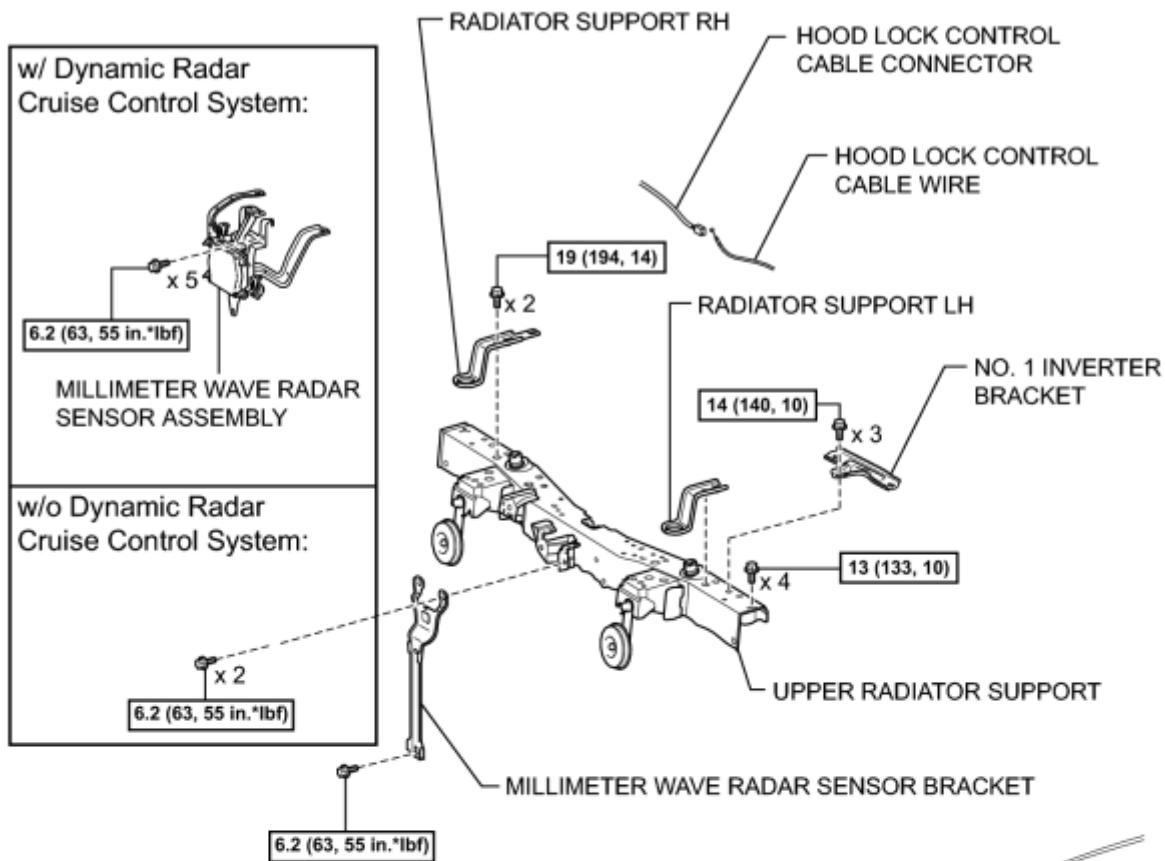

N*m (kgf*cm, ft.*lbf): Specified torque

T

ILLUSTRATION

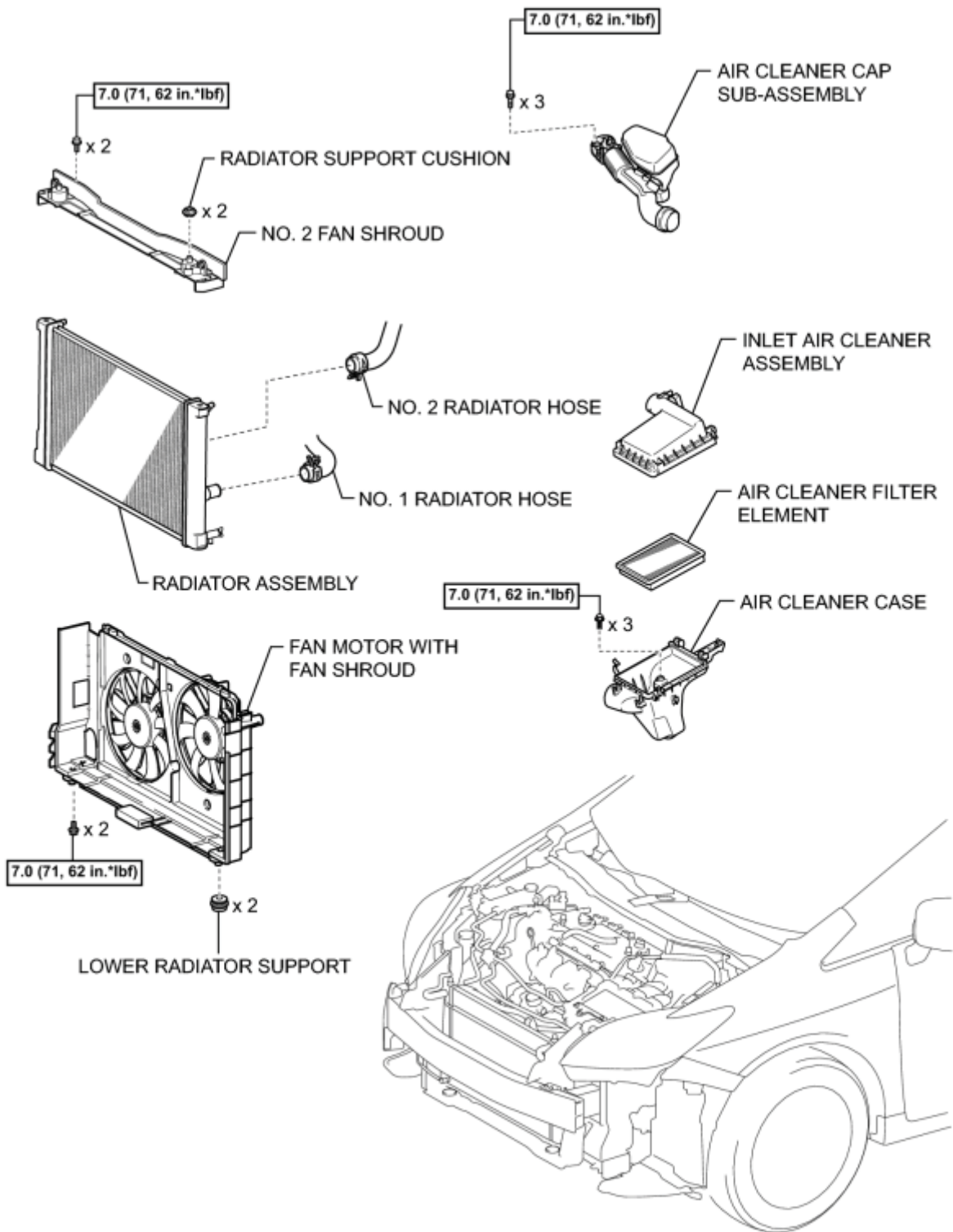

N*m (kgf*cm, ft.*lbf): Specified torque

ON-VEHICLE INSPECTION

1. CHECK RESERVE TANK CAP (for Engine)

(a) Measure the valve opening pressure.

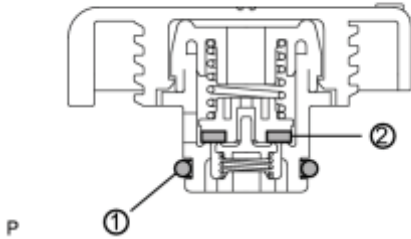

(1) If there are water stains or foreign matter on O-ring 1, clean it with water and finger scouring.

(2) Check that O-ring 1 is not deformed, cracked or swollen.

(3) Apply engine coolant to O-ring 1 and rubber packing 2 before using a radiator cap tester.

(4) When using the cap tester, tilt it upwards 30 degrees or more.

(5) Pump the cap tester several times, and check the maximum pressure*1.

Text in Illustration

*1	Radiator Cap Tester
*2	Radiator Cap

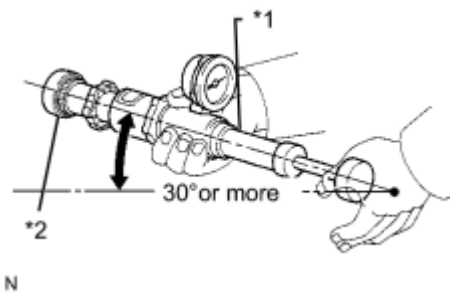

Pumping speed:

1 pump per second

HINT:

*1: Even if the cap cannot maintain the maximum pressure, it is not a defect.

Judgment Criterion:

Item	Specified Condition
Standard value (for brand-new cap)	94 to 122 kPa (1.0 to 1.2 kgf/cm ² , 13.5 to 17 psi)

Minimum standard value (after using cap)	79 kPa (0.8 kgf/cm ² , 11.4 psi)
---	---

If the maximum pressure is less than the minimum standard value, replace the radiator cap sub-assembly.

REMOVAL

1. REMOVE RADIATOR SUPPORT OPENING COVER_ INFO
2. REMOVE REAR NO. 2 FLOOR BOARD (for Separate Type)_ INFO
3. REMOVE REAR DECK FLOOR BOX_ INFO
4. REMOVE REAR NO. 3 FLOOR BOARD_ INFO
5. DISCONNECT CABLE FROM NEGATIVE BATTERY TERMINAL

NOTICE:

When disconnecting the cable, some systems need to be initialized after the cable is reconnected INFO.

6. REMOVE NO. 1 ENGINE UNDER COVER
7. DRAIN ENGINE COOLANT (for Engine)_ INFO
8. DISCONNECT NO. 1 RADIATOR HOSE

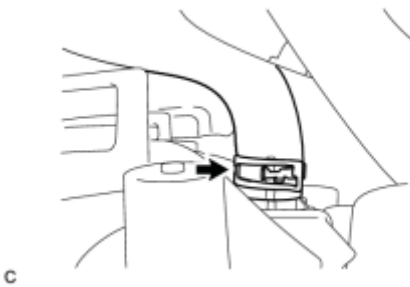

(a) Disconnect the No. 1 radiator hose from the radiator assembly.

9. DISCONNECT NO. 2 RADIATOR HOSE

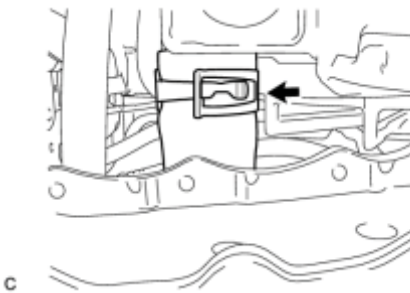

(a) Disconnect the No. 2 radiator hose from the radiator assembly.

10. REMOVE FRONT BUMPER ASSEMBLY_ INFO

11. REMOVE MILLIMETER WAVE RADAR SENSOR ASSEMBLY (w/ Dynamic Radar Cruise Control System) INFO

12. REMOVE MILLIMETER WAVE RADAR SENSOR BRACKET INFO

13. REMOVE NO. 1 INVERTER BRACKET INFO

14. REMOVE HOOD LOCK SUPPORT SUB-ASSEMBLY

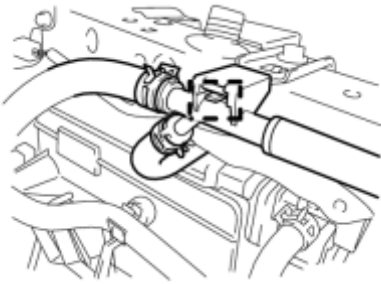

(a) Disconnect the water by-pass hose clamp from the radiator support RH.

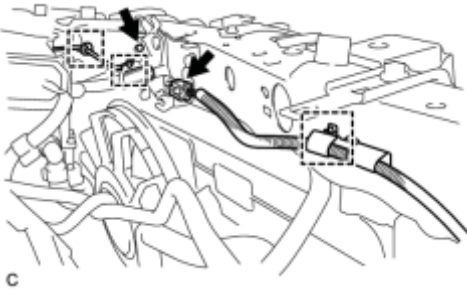

(b) Disconnect the hood lock connector and hood lock control cable wire.

(c) Disconnect the 3 wire harness clamps.

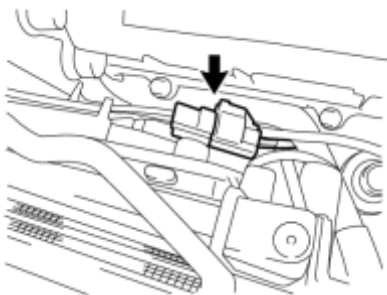

(d) Disconnect the connector from the No. 2 cooling fan motor.

(e) Disconnect the 2 wire harness clamps and connector from the fan shroud and cooling fan motor.

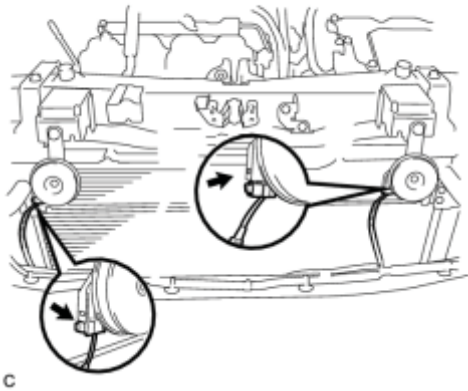
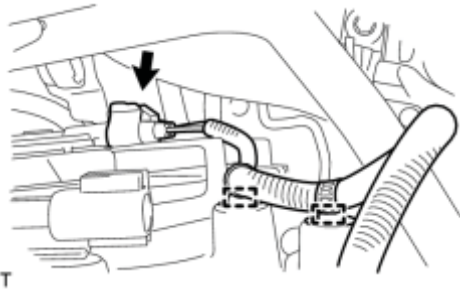

(f) Disconnect the 2 horn connectors.

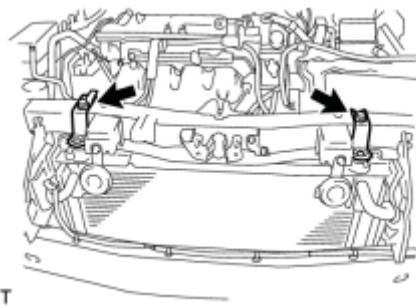

(g) Remove the 2 bolts, radiator support RH and radiator support LH with the 2 cushions from the upper radiator support.

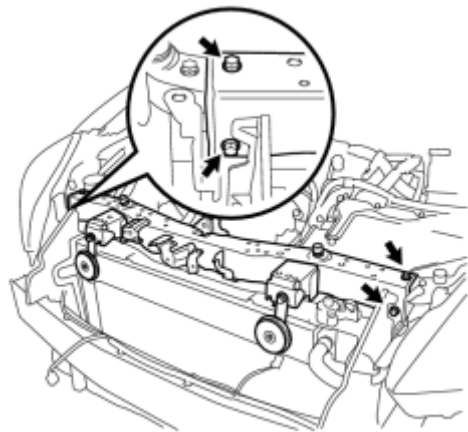

(h) Remove the 4 bolts and upper radiator support.

15. REMOVE AIR CLEANER CAP SUB-ASSEMBLY_ [INFO](#)

16. REMOVE INLET AIR CLEANER ASSEMBLY_ [INFO](#)

17. REMOVE AIR CLEANER CASE_ [INFO](#)

18. REMOVE NO. 2 FAN SHROUD

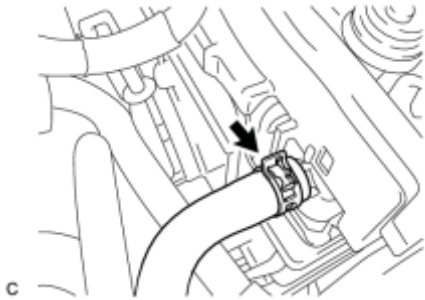

(a) Disconnect the No. 1 water by-pass hose from the radiator assembly.

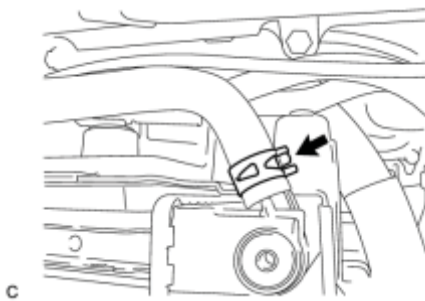

(b) Disconnect the water by-pass hose from the radiator assembly.

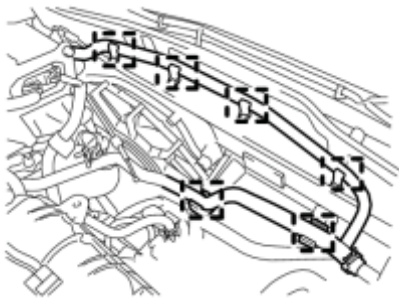

(c) Disconnect the 6 water by-pass hose clamps from the No. 2 fan shroud.

(d) Remove the 2 bolts and No. 2 fan shroud from the radiator assembly.

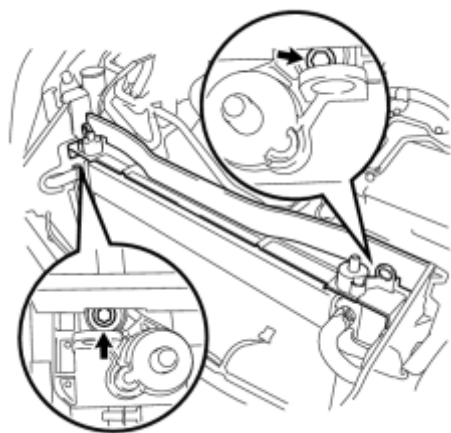

c

19. REMOVE RADIATOR ASSEMBLY

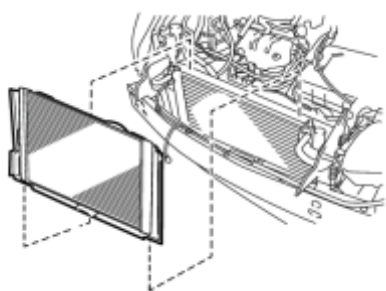

T

(a) Remove the radiator assembly with the fan shroud.

NOTICE:

For vehicles with the air conditioning system, do not apply any excessive force to the cooler condenser assembly or pipe when removing the radiator assembly.

(b) Remove the 2 lower radiator supports.

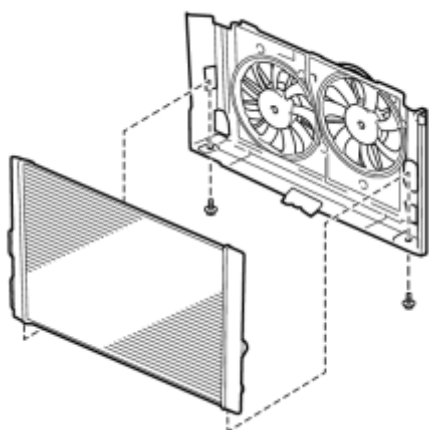

T

(c) Remove the 2 bolts.

(d) Remove the fan shroud from the radiator assembly.

INSTALLATION

1. INSTALL RADIATOR ASSEMBLY

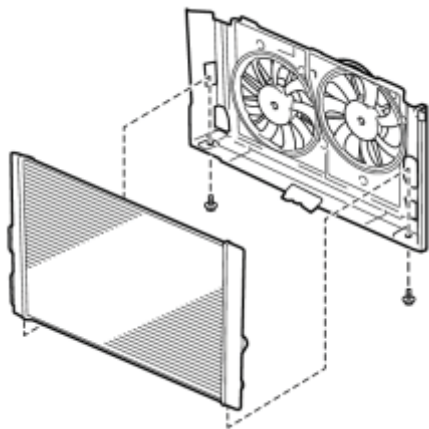

(a) Install the 2 bolts.

Torque: 7.0 N·m (71 kgf·cm, 62in·lbf)

T

(b) Install the fan shroud to the radiator assembly.

(c) Install the 2 lower radiator supports.

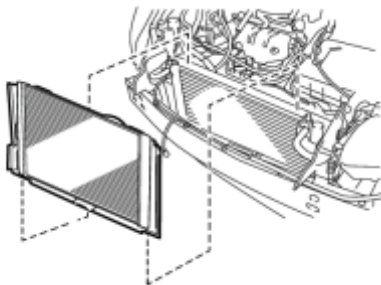

(d) Install the radiator assembly with the fan shroud.

NOTICE:

For vehicles with the air conditioning system, do not apply any excessive force to the cooler condenser assembly or pipe when installing the radiator assembly.

T

2. INSTALL NO. 2 FAN SHROUD

(a) Install the No. 2 fan shroud with the 2 bolts.

Torque: 7.0 N·m (71 kgf·cm, 62in·lbf)

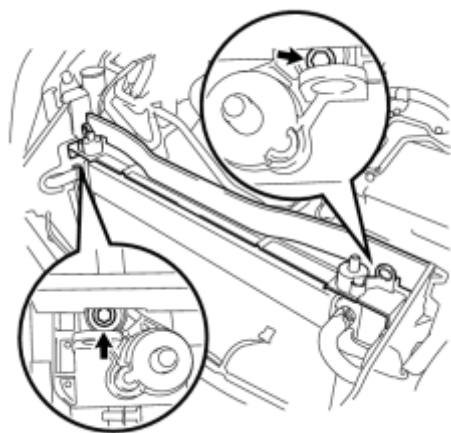

c

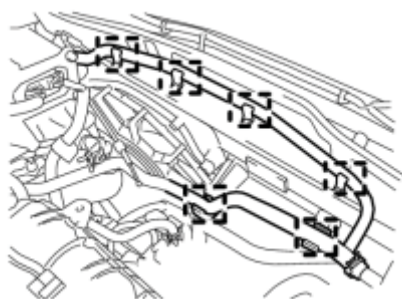

(b) Connect the 6 water by-pass hose clamps to the No. 2 fan shroud.



c

(c) Connect the water by-pass hose to the radiator assembly.



c

(d) Connect the No. 1 water by-pass hose to the radiator assembly.

3. INSTALL AIR CLEANER CASE_ [INFO](#)

4. INSTALL INLET AIR CLEANER ASSEMBLY_ [INFO](#)

5. INSTALL AIR CLEANER CAP SUB-ASSEMBLY NFC

6. INSTALL HOOD LOCK SUPPORT SUB-ASSEMBLY

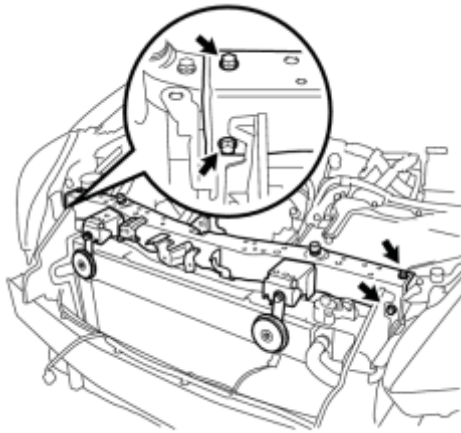

(a) Install the upper radiator support with the 4 bolts.

Torque: **13 N·m (133 kgf·cm, 10ft·lbf)**

c

(b) Install the 2 cushions to the radiator support RH and radiator support LH.

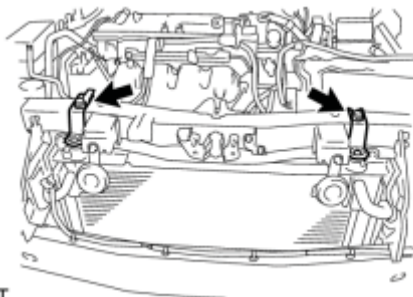

(c) Install the radiator support RH and radiator support LH with the 2 bolts.

Torque: **19 N·m (194 kgf·cm, 14ft·lbf)**

T

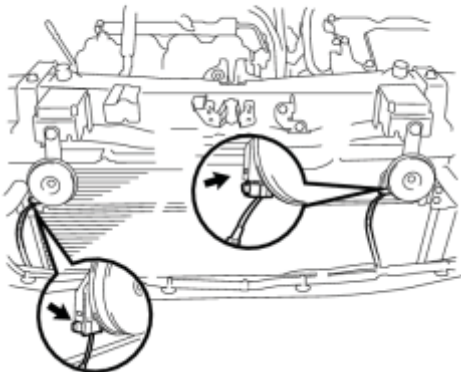

(d) Connect the 2 horn connectors.

c

(e) Connect the 2 wire harness clamps and connector to the fan shroud and cooling fan motor.

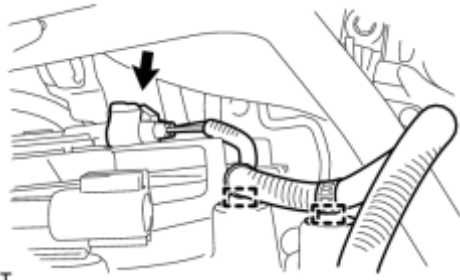

T

(f) Connect the connector to the No. 2 cooling fan motor.

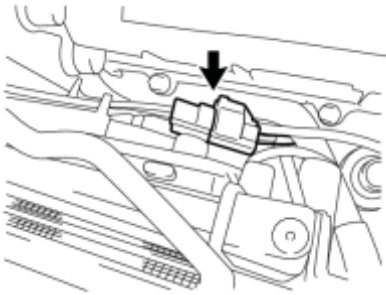

T

(g) Connect the hood lock connector and hood lock control cable wire.

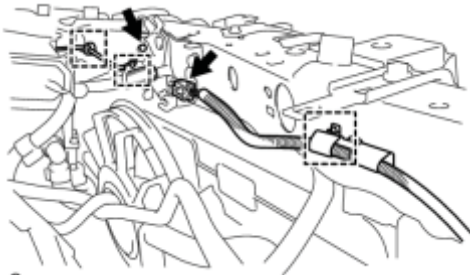

C

(h) Connect the 3 wire harness clamps.

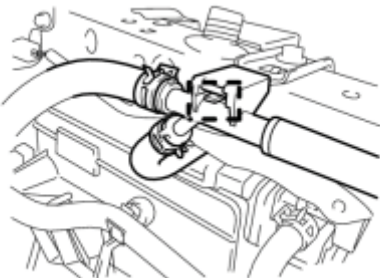

T

(i) Connect the water by-pass hose clamp to the radiator support RH.

7. INSTALL NO. 1 INVERTER BRACKET_ INFO

8. INSTALL MILLIMETER WAVE RADAR SENSOR BRACKET_ INFO

9. INSTALL MILLIMETER WAVE RADAR SENSOR ASSEMBLY (w/ Dynamic Radar Cruise Control System)_ INFO

10. INSTALL FRONT BUMPER ASSEMBLY_ [INFO](#)

11. CONNECT NO. 2 RADIATOR HOSE

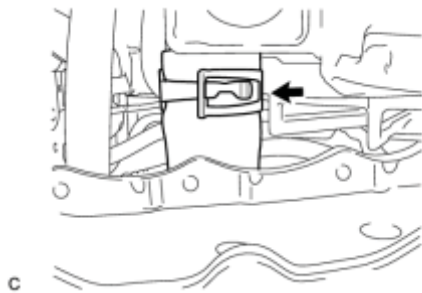

(a) Connect the No. 2 radiator hose to the radiator assembly with the clamp.

12. CONNECT NO. 1 RADIATOR HOSE



(a) Connect the No. 1 radiator hose to the radiator assembly with the clamp.

13. ADD ENGINE COOLANT (for Engine)_ [INFO](#)

14. INSPECT FOR COOLANT LEAK (for Engine)_ [INFO](#)

15. INSTALL NO. 1 ENGINE UNDER COVER

16. CONNECT CABLE TO NEGATIVE BATTERY TERMINAL

NOTICE:

When disconnecting the cable, some systems need to be initialized after the cable is reconnected [INFO](#).

17. INSTALL REAR NO. 3 FLOOR BOARD_ [INFO](#)

18. INSTALL REAR DECK FLOOR BOX_ [INFO](#)

19. INSTALL REAR NO. 2 FLOOR BOARD (for Separate Type)_ [INFO](#)

20. INSTALL RADIATOR SUPPORT OPENING COVER_ [INFO](#)

21. ADD WASHER FLUID (w/ Headlight Cleaner System)_ [INFO](#)

22. PREPARE VEHICLE FOR FOG LIGHT AIM ADJUSTMENT (w/ Fog Light) INFO

23. PREPARE FOR FOG LIGHT AIMING INFO

24. INSPECT FOG LIGHT AIMING INFO

25. ADJUST FOG LIGHT AIMING INFO