

COMPONENTS

ILLUSTRATION

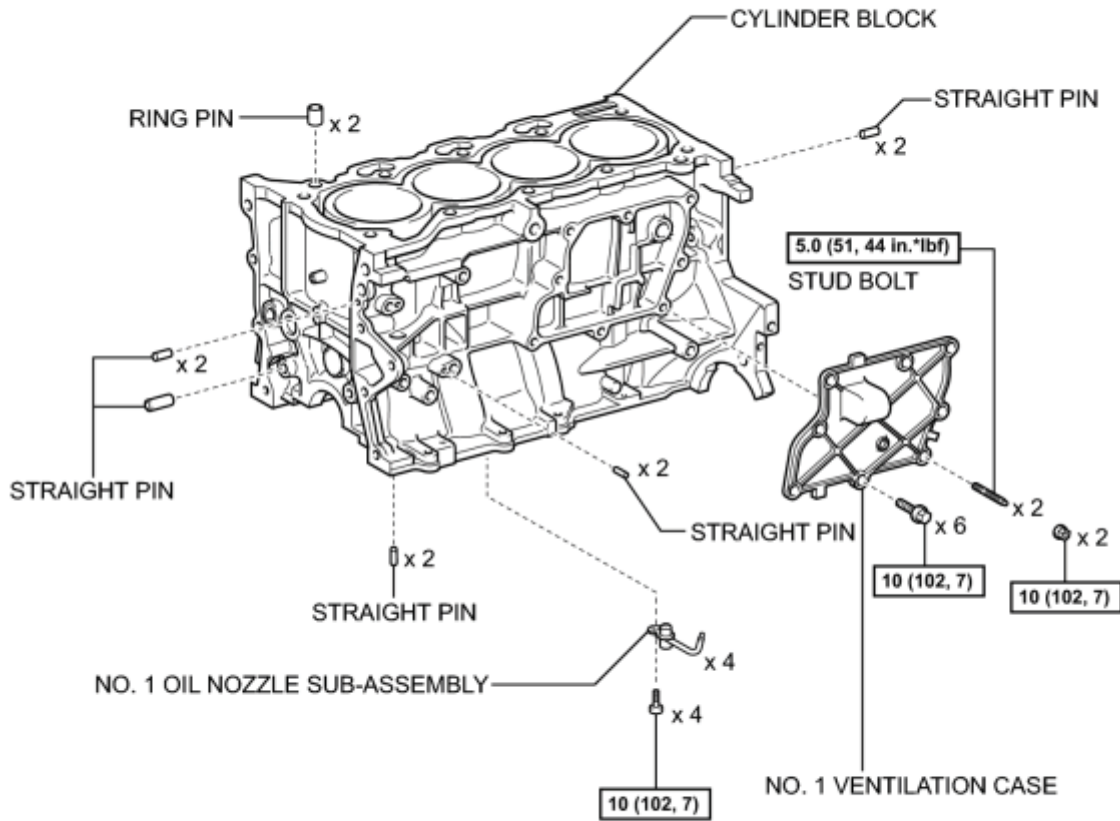

10 (102, 7): Specified torque

ILLUSTRATION

DISASSEMBLY

1. REMOVE NO. 1 VENTILATION CASE

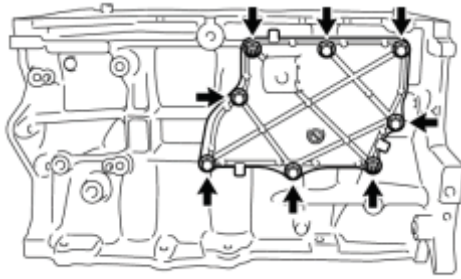

(a) Remove the 6 bolts and 2 nuts.

T

(b) Remove the ventilation case by prying between the ventilation case and cylinder block with a screwdriver as shown in the illustration.

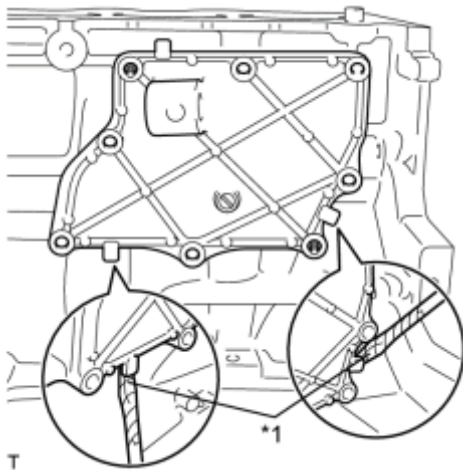

T

Text in Illustration

*1	Protective Tape
----	-----------------

NOTICE:

Be careful not to damage the contact surfaces of the cylinder block and No. 1 ventilation case.

HINT:

Tape the screwdriver tip before use.

2. INSPECT CONNECTING ROD THRUST CLEARANCE

(a) Using a dial indicator, measure the thrust clearance while moving the connecting rod cap back and forth.

Standard thrust clearance:

0.160 to 0.342 mm (0.00630 to 0.0135 in.)

Maximum thrust clearance:

0.342 mm (0.0132 in.)

If the thrust clearance is greater than the maximum, replace the connecting rod assemblies as necessary. If necessary, replace the crankshaft.

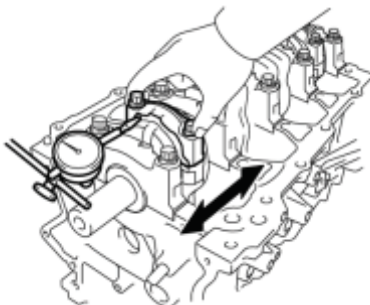

T

3. INSPECT CONNECTING ROD OIL CLEARANCE

(a) Check that the matchmarks on the connecting rod and cap are aligned

Seal packing:

Toyota Genuine Seal Packing Black, Three Bond 1207B or equivalent

Application Specification:

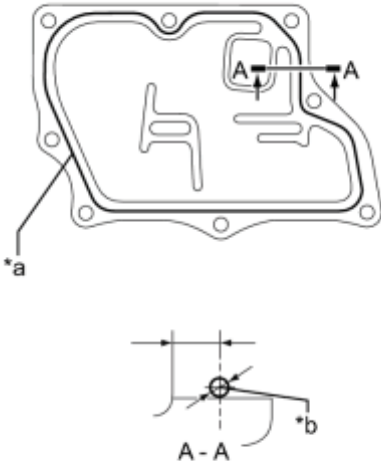

Seal Packing Diameter	Distance from inside edge of cover to center of seal packing
2.0 to 3.0 mm (0.0787 to 0.118 in.)	3.0 mm (0.118 in.)

- Remove any oil from the contact surface.
- Install the ventilation case within 3 minutes and tighten the bolts and nuts within 15 minutes of applying seal packing.
- Do not start the engine for at least 2 hours after installation.

T

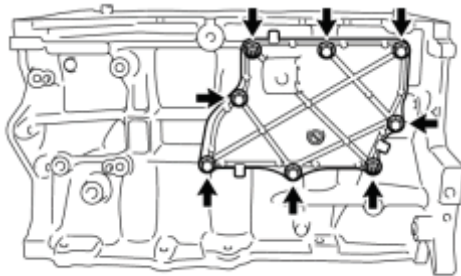

(b) Install the ventilation case with the 6 bolts and 2 nuts.

Torque: 10 N·m (102 kgf·cm, 7ft·lbf)

T